

Chopper Stabilized (Auto-Zero) Precision Op Amps

CHOPPER AMPLIFIERS

For the lowest offset and drift performance, chopper-stabilized (auto-zero) amplifiers may be the only solution. The best bipolar amplifiers offer offset voltages of $25 \mu\text{V}$ and $0.1 \mu\text{V}/^\circ\text{C}$ drift. Offset voltages less than $5 \mu\text{V}$ with practically no measurable offset drift are obtainable with choppers, albeit with some penalties.

A basic chopper amplifier circuit is shown in Figure 1 below. When the switches are in the "Z" (auto-zero) position, capacitors C2 and C3 are charged to the amplifier input and output offset voltage, respectively. When the switches are in the "S" (sample) position, V_{IN} is connected to V_{OUT} through the path comprised of R1, R2, C2, the amplifier, C3, and R3. The chopping frequency is usually between a few hundred Hz and several kHz, and it should be noted that because this is a sampling system, the input frequency must be much less than one-half the chopping frequency in order to prevent errors due to aliasing. The R1-C1 combination serves as an antialiasing filter. It is also assumed that after a steady state condition is reached, there is only a minimal amount of charge transferred during the switching cycles. The output capacitor, C4, and the load, R_L , must be chosen such that there is minimal V_{OUT} droop during the auto-zero cycle.

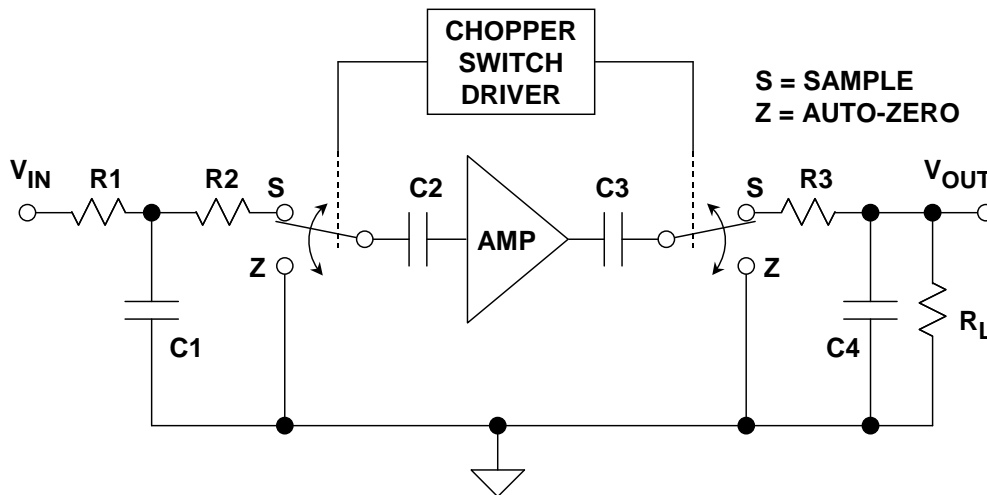

Figure 1: Classic Chopper Amplifier

AUTO-ZERO CHOPPER STABILIZED OP AMP

The basic chopper amplifier of Fig. 1 can pass only very low frequencies because of the input filtering required to prevent aliasing. In contrast to this, the *chopper-stabilized* architecture shown in Figure 2 is most often used in chopper amplifier implementations.

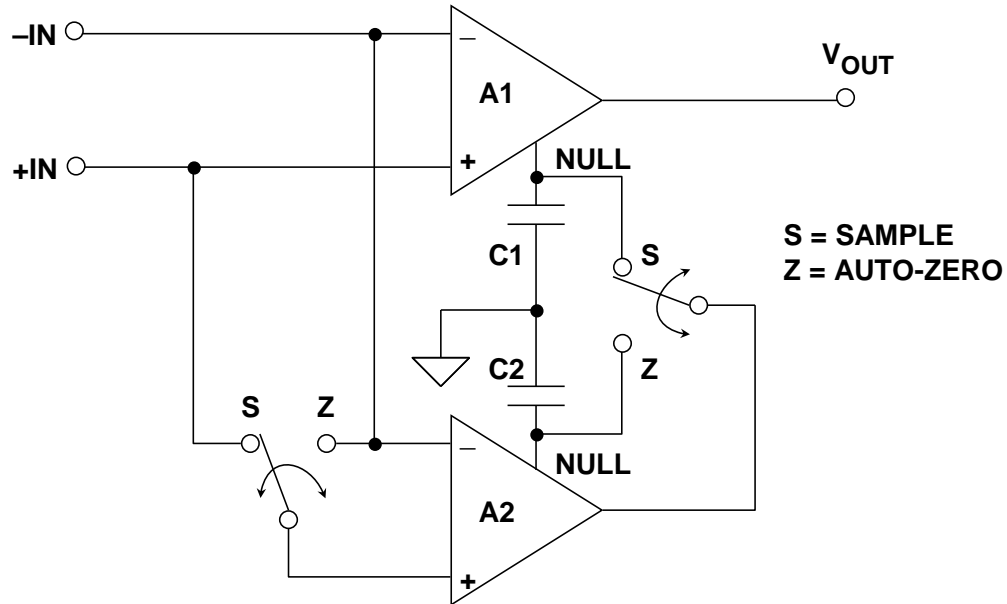

Figure 2: Modern Auto-Zero (Chopper-Stabilized) Op Amp

In this circuit, A1 is the *main* amplifier, and A2 is the *nulling* amplifier. In the sample mode (switches in "S" position), the nulling amplifier, A2, monitors the input offset voltage of A1 and drives its output to zero by applying a suitable correcting voltage at A1's null pin. Note, however, that A2 also has an input offset voltage, so it must correct its own error before attempting to null A1's offset. This is achieved in the auto-zero mode (switches in "Z" position) by momentarily disconnecting A2 from A1, shorting its inputs together, and coupling its output to its own null pin. During the auto-zero mode, the correction voltage for A1 is momentarily held by C1. Similarly, C2 holds the correction voltage for A2 during the sample mode. In modern IC chopper-stabilized op amps, the storage capacitors C1 and C2 are on-chip.

Note in this architecture that *the input signal is always connected to the output, through A1*. The bandwidth of A1 thus determines the overall signal bandwidth, and the input signal is not limited to less than one-half the chopping frequency as in the case of the traditional chopper amplifier architecture. However, the switching action does produce small transients at the chopping frequency, that can mix with the input signal frequency and produce intermodulation distortion.

A patented spread-spectrum technique is used in the [AD8571/AD8572/AD8574](#) series of single-supply chopper-stabilized op amps, to virtually eliminate intermodulation effects. These devices use a pseudorandom chopping frequency swept between 2 kHz and 4 kHz. Figure 3 compares the intermodulation distortion of a traditional chopper stabilized op amp.

The ([AD8551/AD8552/AD8554](#), left) uses a fixed 4 kHz chopping frequency, and the [AD8571/AD8572/AD8574](#) (right) uses the pseudorandom chopping frequency.

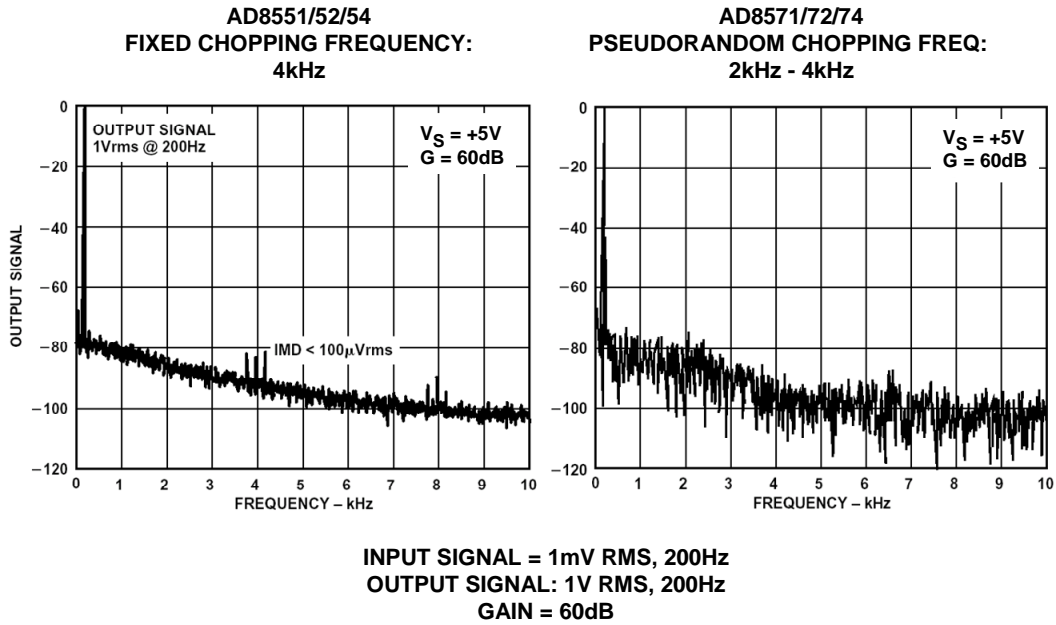

Figure 3: Intermodulation Product: Fixed Versus Pseudorandom Chopping Frequency

A comparison between fixed and pseudorandom chopping on the voltage noise is shown in Figure 4 below. Notice for the fixed chopping frequency, there are distinct peaks in the noise spectrum at the odd harmonics of 4 kHz, whereas with pseudorandom chopping, the spectrum is much more uniform, although the average noise level is higher.

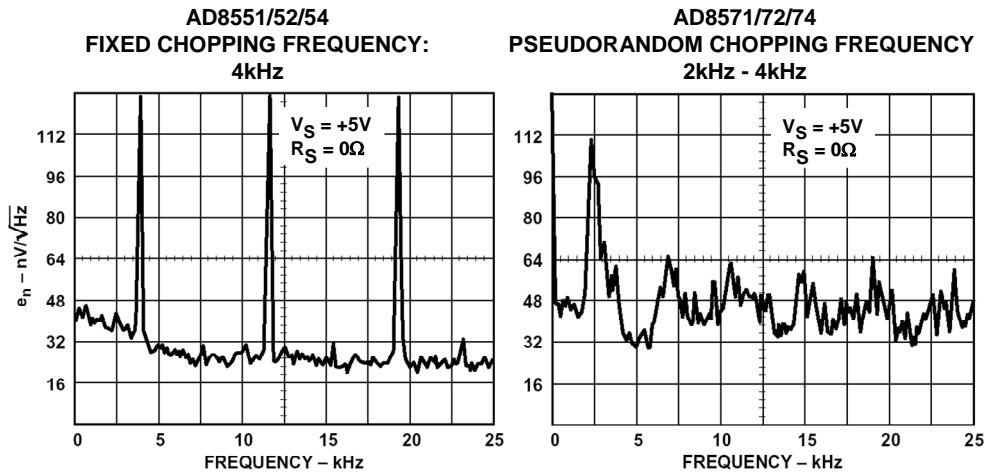

Figure 4: Voltage Noise Spectral Density Comparison: Fixed Versus Pseudorandom Chopping Frequency

Another method for reducing the intermodulation effects the switching action of auto-zero amplifiers is through a patented combination of auto-zeroing and chopping as used in the [AD8628/AD8629/AD8630](#) family. This unique topology allows these amplifiers to maintain their low offset voltage over a wide temperature range and over their operating lifetime.

The AD8628/AD8629/AD8630 also optimize the noise and bandwidth over previous generations of auto-zero amplifiers, offering the lowest voltage noise of any auto-zero amplifier by more than 50%. Other designs use either auto-zeroing or chopping to add precision to the specifications of an amplifier. Auto-zeroing results in low noise energy at the auto-zeroing frequency, at the expense of higher low frequency noise due to aliasing of wideband noise into the auto-zeroed frequency band. Chopping results in lower low frequency noise at the expense of larger noise energy at the chopping frequency.

The [AD8628/AD8629/AD8630](#) family uses both auto-zeroing and chopping in a patented "ping-pong" arrangement to obtain lower low frequency noise together with lower energy at the chopping and auto-zeroing frequencies, maximizing the signal-to-noise ratio for the majority of applications without the need for additional filtering. The relatively high clock frequency of 15 kHz simplifies filter requirements for a wide, useful, noise-free bandwidth. The noise spectral density of the family is shown in Figure 5.

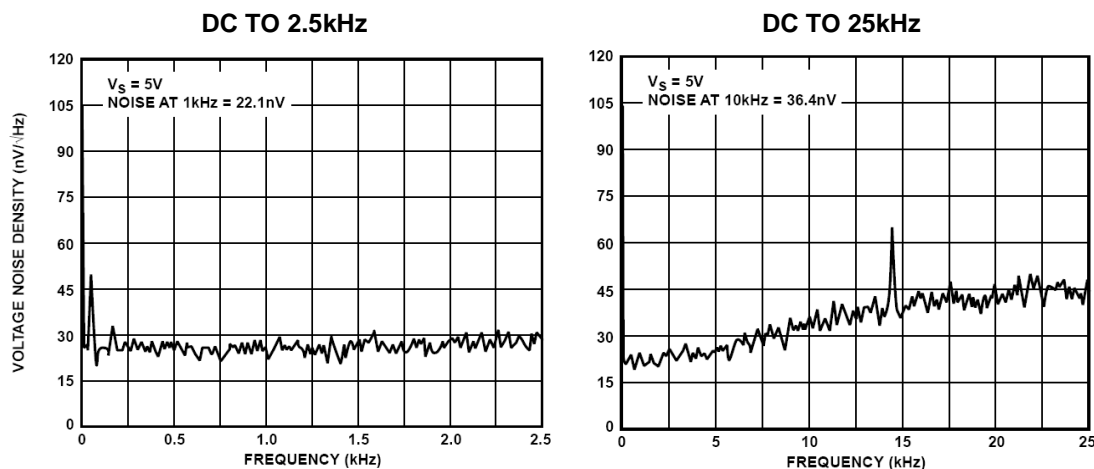

Figure 5: Voltage Noise Spectral Density of AD8628/AD8629/AD8630 Family of Precision Zero-Drift, Auto-Zero Op Amps

The AD8628 is among the few auto-zero amplifiers offered in the 5-lead TSOT package. This provides a significant improvement over the ac parameters of the previous auto-zero amplifiers. The AD8628/AD8629/AD8630 have low noise over a relatively wide bandwidth (0 Hz to 10 kHz) and can be used where the highest dc precision is required. In systems with signal bandwidths of from 5 kHz to 10 kHz, the AD8628/AD8629/AD8630 provide true 16-bit accuracy, making them the best choice for very high resolution systems.

Key features of the AD8628/AD8629/AD8630 family are shown in Figure 6.

- ◆ **Single Supply: +2.7V to +5V**
- ◆ **1 μ V Typical Input Offset Voltage**
- ◆ **0.002 μ V/ $^{\circ}$ C Typical Input Offset Voltage Drift**
- ◆ **130dB Typical CMR, PSR**
- ◆ **0.85mA Typical Supply Current/Amplifier**
- ◆ **10 μ s Overload Recovery Time**
- ◆ **22nV/ $\sqrt{\text{Hz}}$ Input Voltage Noise @ 1kHz**
- ◆ **Patented Auto-Zero and Chopper-Stabilized Technique @ 15kHz Switching Frequency**
- ◆ **2.5MHz Gain-Bandwidth Product**
- ◆ **AD8628 (Single) in TSOT and SOT-23 Packages**
- ◆ **AD8629 (Dual), AD8630 (Quad)**

Figure 6: Key Features of the AD8628/29/30 Family of Precision Auto-Zero Op Amps

It should be noted that extreme care must be taken when applying all of the chopper stabilized devices. This is because in order to fully realize the full offset and drift performance inherent to the parts, parasitic thermocouple effects in external circuitry must be avoided.

NOISE CONSIDERATIONS FOR CHOPPER-STABILIZED OP AMPS

It is interesting to consider the effects of a chopper amplifier on low frequency 1/f noise. If the chopping frequency is considerably higher than the 1/f corner frequency of the input noise, the chopper-stabilized amplifier continuously nulls out the 1/f noise on a sample-by-sample basis. Theoretically, a chopper op amp therefore has no 1/f noise. However, the chopping action produces wideband noise which is generally much worse than that of a precision bipolar op amp.

Figure 7 below shows the noise of a precision bipolar amplifier ([OP177](#)) versus that of the [AD8628/AD8629/AD8630](#) chopper-stabilized op amp. The peak-to-peak noise in various bandwidths is calculated for each in the table below the graphs.

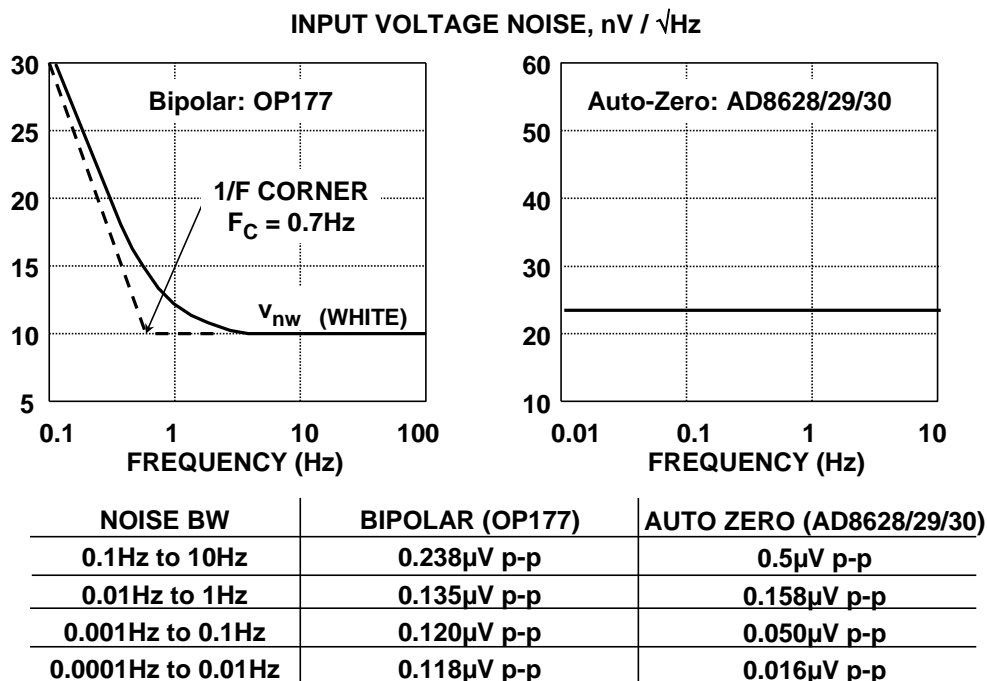

Figure 7: Noise: Bipolar Versus Auto-Zero Op Amp

Note from the data that as the frequency is lowered, the auto-zero amplifier noise continues to drop, while the bipolar amplifier noise approaches a limit determined by the 1/f corner frequency and its white noise. Notice that only at very low frequencies (<0.1Hz) is the chopper noise performance superior to that of the bipolar op amp.

In order to take advantage of the chopper op amp's lack of 1/f noise, much filtering is required—otherwise the total noise of a chopper will always be worse than a good bipolar op amp. Choppers should therefore be selected on the basis of their low offset and drift—not because of their lack of 1/f noise.

REFERENCES

1. Hank Zumbahlen, *Basic Linear Design*, Analog Devices, 2006, ISBN: 0-915550-28-1. Also available as [Linear Circuit Design Handbook](#), Elsevier-Newnes, 2008, ISBN-10: 0750687037, ISBN-13: 978-0750687034. Chapter 1.
2. Walter G. Jung, *Op Amp Applications*, Analog Devices, 2002, ISBN 0-916550-26-5, Also available as [Op Amp Applications Handbook](#), Elsevier/Newnes, 2005, ISBN 0-7506-7844-5. Chapter 1.

Copyright 2009, Analog Devices, Inc. All rights reserved. Analog Devices assumes no responsibility for customer product design or the use or application of customers' products or for any infringements of patents or rights of others which may result from Analog Devices assistance. All trademarks and logos are property of their respective holders. Information furnished by Analog Devices applications and development tools engineers is believed to be accurate and reliable, however no responsibility is assumed by Analog Devices regarding technical accuracy and topicality of the content provided in Analog Devices Tutorials.