

2JCIE-BL01

Environment Sensor

Sense a variety of environmental information

- Sense your surrounding environment and helps you to assist your comprehensive assessment of indoor comfort
- Battery operable 46 x 39 x 15mm small package including 7 sensors
- Based on BluetoothR low energy, Sensor beacon can simplify the deployment
- Embedded memory for data logging can keep track of surrounding environments



RoHS compliant

 Refer to *Safety Precautions* on page 19.

Ordering Information

Model	Communication Interface	Sensors
2JCIE-BL01	Bluetooth low energy	Temperature, Humidity, Light, UVI, Absolute pressure, Noise, Acceleration

Example of use

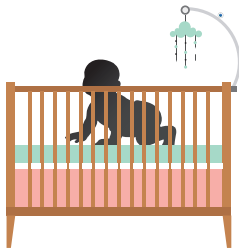

Remote Care (Infant / Elderly / Pet)



Heatstroke Prevention



Create a Comfortable Office Environment

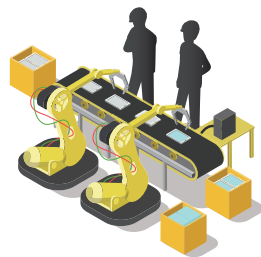

Improvement in Work Environment



Designing a Comfortable Sleep Condition

2JCIE-BL01

Specifications

Item	Specification
Power Supply	CR2032 × 1 (3VDC)
Sensors	Temperature, Humidity, Light, UVI, Absolute pressure, Noise, Acceleration*1
Interface	Bluetooth low energy *2 : GAP advertisement / Custom GATT profile
Communication range	Approx. 10m *3
Operating Temperature	-10 to 60 degC
Operating Humidity	30 to 85 %RH
Battery Life	Approx. 6 months (5 min. measurement interval / one time per day connection) *3
Dimensions	Approx. 46 × 39 × 15 mm
Weight	Approx. 16 g (incl. battery)

Note: 1. Acceleration values are only provided in specific operation mode. Please refer to Communication Interface Manual for more details.

Note: 2. The Bluetooth word mark and logos are registered trademarks owned by Bluetooth SIG, Inc. and any use of such marks by OMRON Corporation is under license.

Note: 3. Communication distance and battery life may vary according to obstacles between the communication equipment, radio wave conditions.

Application example

- Environment Sensor will sense your surrounding environment and helps you to assist your comprehensive assessment of indoor comfort.
- You can visualize the environmental information by transferring your sensor data to your smartphone via Bluetooth low energy technology.
- It is possible to notify the environmental changes and uncomfortable conditions to your smartphone via push notifications, and supports a comfortable environment management.
- By transmitting sensor data in broadcaster mode, you can easily build up a system in combination with common gateway devices.

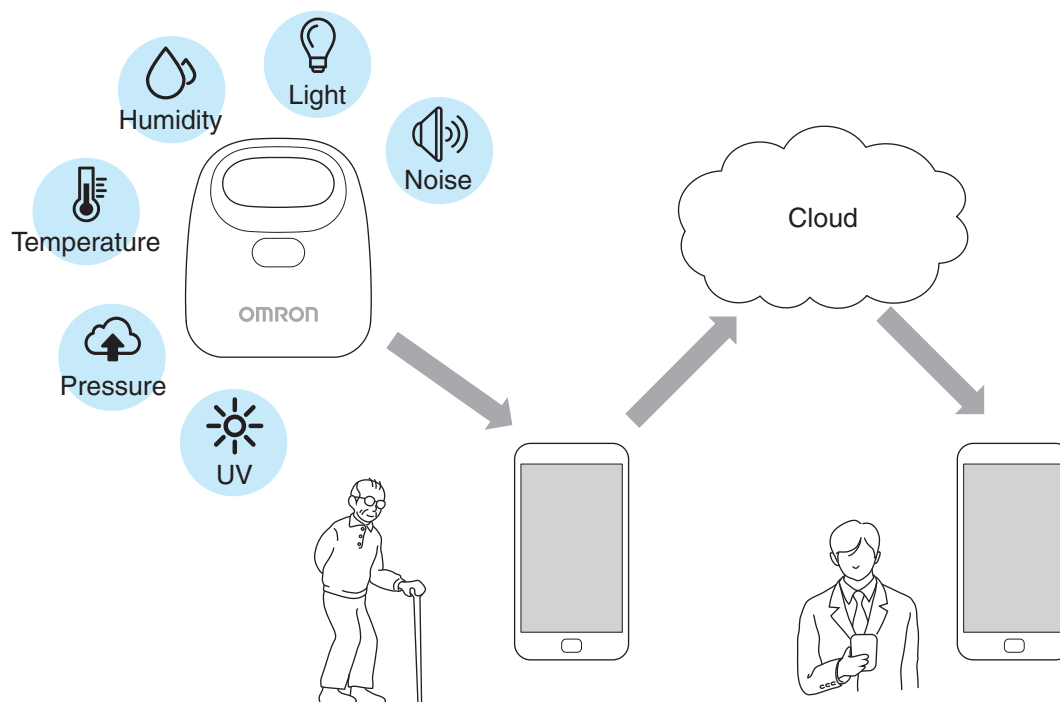

Absolute maximum ratings

Item	Ratings
Power Supply	-0.3 to 3.6 V
Temperature range	-20 to 70 degC

Rating (Recommended operating condition)

Item	Min.	Typ.	Max.	Unit
Power Supply	2.7	3.0	3.3	V
Temperature range	15	25	45	degC

Basic performance

Item	Measurable range	Accuracy
Temperature	-10 to 60 degC	±2 degC
Humidity	0 to 100 %RH	±5 %RH
Light	10 to 2000 lx	±100 lx
UV Index	1 to 11	For reference *1 *2
Barometric pressure	700 to 1100 hPa	±4 hPa
Sound noise	37 to 89 dB	For reference *1
Acceleration (3-axis)	-2000 to 2000 mg	For reference *1 *3

* Supply voltage: 3.0V, Ambient temperature: 15 to 35 degC, unless otherwise specified.

* These values are specified under standard test condition, and do not guarantee the performance under the complex conditions.

Note: 1. These types of output are provided for referential use only, and these values do not guarantee the normal operation within that range.

Note: 2. Information on UV Index is just for reference. And it does not protect you from danger and various damage from UV light.

Note: 3. Acceleration values are only provided in specific operation mode. Please refer to Communication Interface Manual for more details.

Block diagram

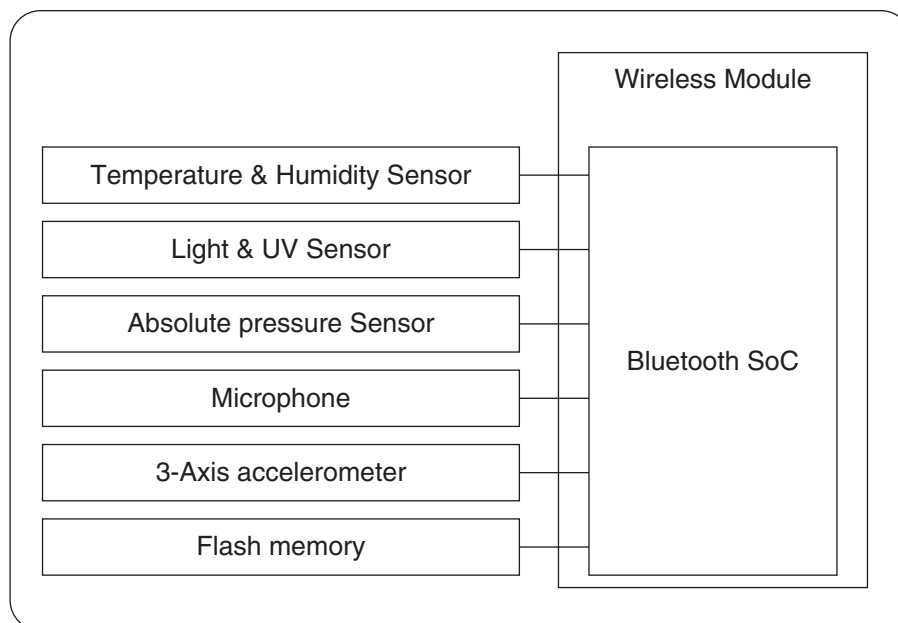

Dimensions (Unit: mm)

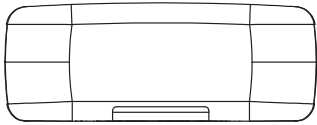
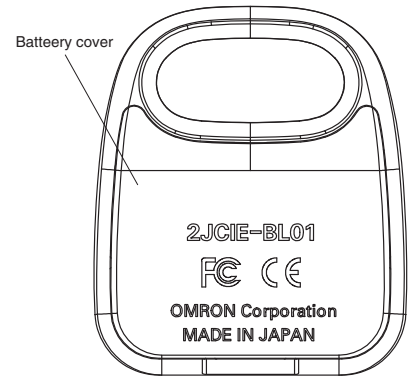
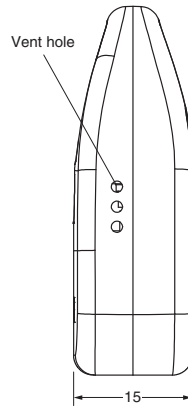
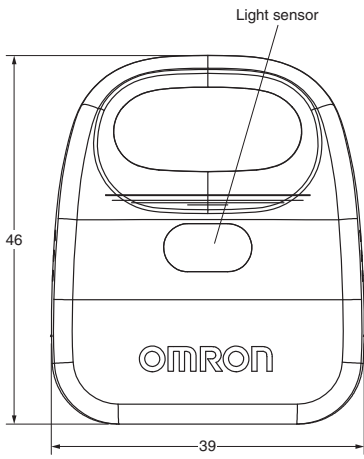
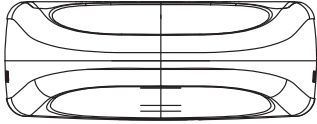

Packing

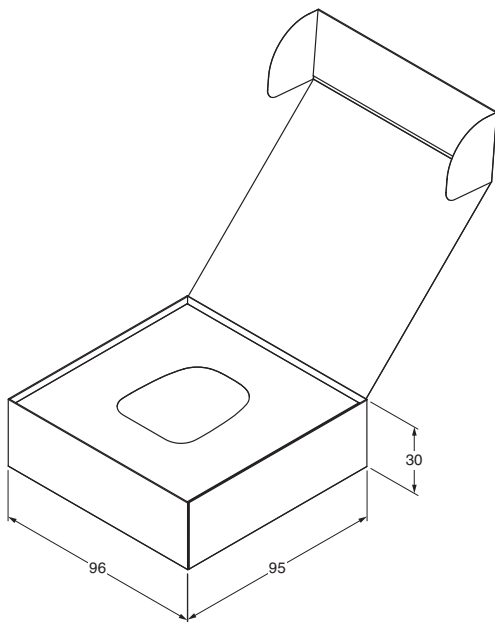
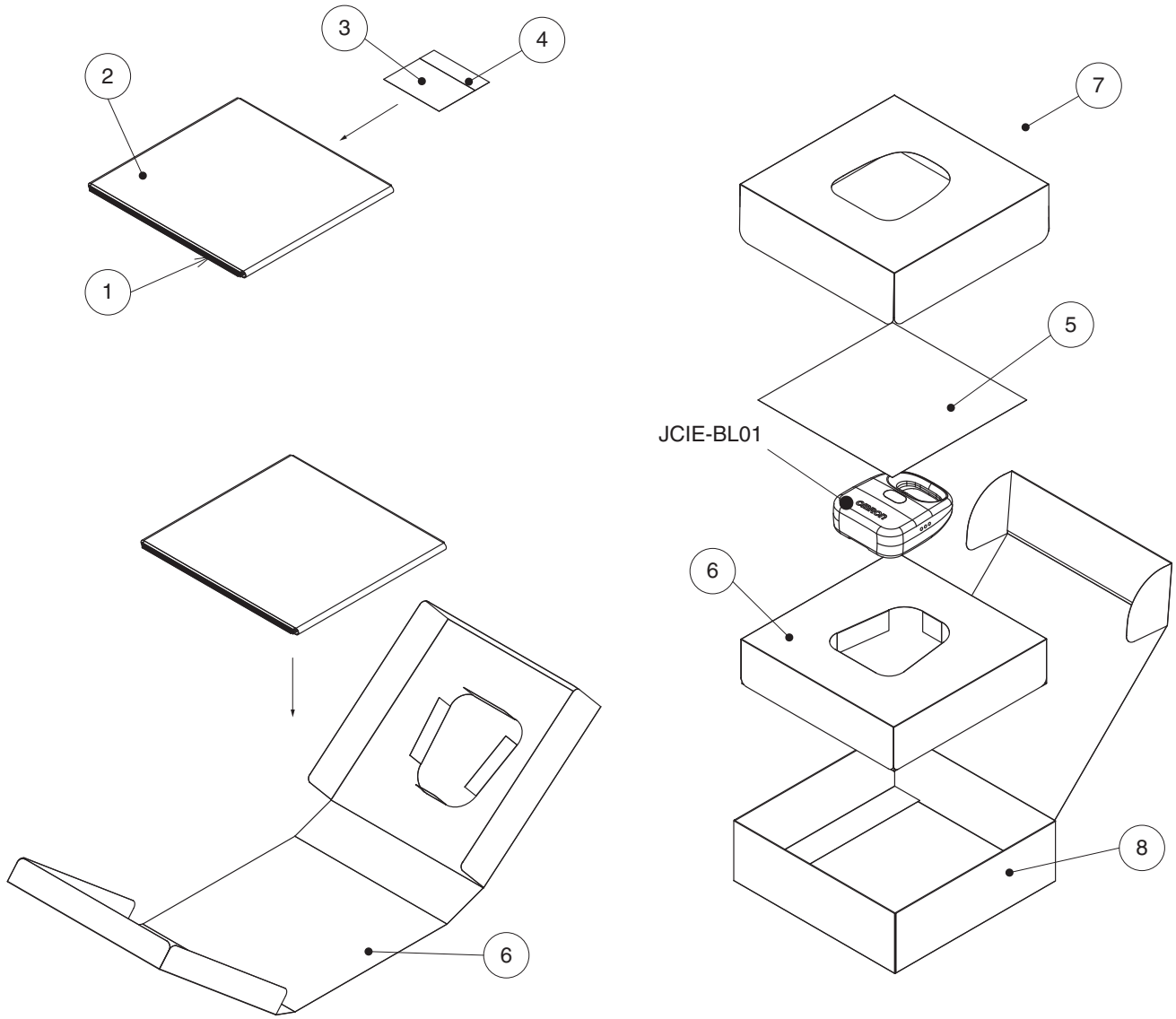

#	Item
1	Instruction manual
2	Manual sleeve
3	Battery (CR2032)
4	Battery bag
5	Protection film
6	Inner box (A)
7	Inner box (B)
8	Outer box

Important Safety Information

To assure the correct use of the product basic safety measures should always be followed including the warnings and cautions listed in this document.

Warning

* Warning: Improper use may result in death or serious injury.

- Keep the battery out of the reach of young children.
If young children swallow the battery, immediately consult a doctor.
- Do not throw the battery into fire.
The battery may explode.
- In places where radio communications are prohibited, remove the battery to turn off the Bluetooth.
- Do not place the unit closer than 22cm (9 inches) from implantable medical devices such as pacemakers.
- Keep the unit out of the reach of young children.
If young children swallow any small piece, immediately consult a doctor.
- Please stop using the unit immediately, if there is strange smell or smoke from the unit.
- Do not subject the unit to extreme temperatures, humidity, moisture, or direct sunlight.
- Internal condensation due to severe change in temperature may cause malfunction.
- In high temperature or low temperature environment, battery life may be extremely short due to the characteristics of the battery used.
- Please do not leave in the car.
Prolonged exposure to the high temperature causes explosion, fire or malfunction of the internal battery.

Caution

* Caution: Improper use may result in minor or moderate injury to the user or damage to the equipment.

- Do not use the unit in the field of strong electromagnetic waves and static electricity.
- Do not insert the battery with the polarities in the wrong direction.
- Always use the type of battery indicated.
- Remove the battery from this unit when you are not going to use it for a long period of time (approximately 3 months or more).
- This unit is not a measurement instrument.
The measured values must be treated as a reference, and do not use it for the purpose of verification or diagnosis.
- Please read the instruction manual of your smartphone or tablet for the wireless communication.
- Do not replace the battery during the wireless communication.
- Do not swing the unit by the strap.
Swinging the unit while holding the strap may cause an injury.

Precautions for Correct Use

- Do not disassemble or modify the unit.
- Do not subject the unit to strong shocks or vibrations, drop it, step on it.
- Do not apply a strong force, twist, deflection and mechanical stress on the ring portion.
- Do not immerse the unit or any of the components in water.
The unit is not waterproof. Do not wash it or touch it with wet hands. Be careful that water does not get into the unit.
- Depending on the surrounding environment and the mounting position, the measured characteristic may vary. The measured values must be treated as a reference.
 1. Do not subject the unit to extreme temperatures, humidity, moisture, or direct sunlight.
 2. Do not subject the unit to water, oil or chemical materials.
 3. Do not use the unit where it will be exposed to dew condensation.
 4. Do not use the unit where it will be exposed to flammable gas or corrosive vapors.
 5. Do not use the unit where it will be exposed to dust, saline matter or iron powder.
- Batteries are not a part of your regular household waste.
You must return batteries to your municipality's public collection or wherever batteries of the respective type are being sold.
- Dispose of the unit, battery, and components according to applicable local regulations.
Unlawful disposal may cause environmental pollution.
- This Product operates in the unlicensed ISM band at 2.4GHz. In case this Product is used around the other wireless devices including microwave and wireless LAN, which operate same frequency band of this Product, there is a possibility that interference occurs between this Product and such other devices. If such interference occurs, please stop the operation of other devices or relocate this Product before using this Product or do not use this Product around the other wireless devices.
- Due to the use of radio waves, third parties may intercept transmissions either deliberately or accidentally. Do not use this Product for matters related to vital secrets or human lives.
- Application examples provided in this document are just for reference. In actual applications, confirm its functions, limitations and safety before using this Product.

Acknowledgement

This work was funded by ImPACT Program of Council for Science, Technology and Innovation (Cabinet Office, Government of Japan).
Program: "Innovative Cybernic System for a ZERO Intensive Nursing Care Society" (Program Manager: Yoshiyuki Sankai)

• Application examples provided in this document are for reference only. In actual applications, confirm equipment functions and safety before using the product.
• Consult your OMRON representative before using the product under conditions which are not described in the manual or applying the product to nuclear control systems, railroad systems, aviation systems, vehicles, combustion systems, medical equipment, amusement machines, safety equipment, and other systems or equipment that may have a serious influence on lives and property if used improperly. Make sure that the ratings and performance characteristics of the product provide a margin of safety for the system or equipment, and be sure to provide the system or equipment with double safety mechanisms.

Note: Do not use this document to operate the Unit.

Mouser Electronics

Authorized Distributor

Click to View Pricing, Inventory, Delivery & Lifecycle Information:

[Omron:](#)

[2JCIE-BL01](#)