



**IEEE® 802.15.4/THREAD**

**MODULE**

**KW22D512VHA5**

**DATASHEET**

**REVISION 0.1**



## Copyright Info

The information contained in this document is the proprietary information of Volansys Technologies Pvt., Ltd. The contents are confidential and any disclosure to persons other than the officers, employees, agents or subcontractors of the owner or licensee of this document, without the prior written consent of Volansys, is strictly prohibited.

Further, no portion of this document may be reproduced, stored in a retrieval system, or transmitted in any form or by any means, electronic or mechanical, including photocopying and recording, without the prior written consent of Volansys, the copyright holder.

Volansys publishes this document without making any warranty as to the content contained herein. Further Volansys reserves the right to make modifications, additions and deletions to this document due to typographical errors, inaccurate information, or improvements to products mentioned in the document at any time and without notice. Such changes will, nevertheless be incorporated into new editions of this document.

CONFIDENTIAL

**Table of Contents**

**1. DOCUMENT DETAILS** ..... 4

    1.1. REVISION HISTORY .....4

    1.2. REFERENCES .....4

**2. INTRODUCTION** ..... 5

**3. PRODUCT OVERVIEW**..... 6

**4. MODULE PINOUTS** ..... 7

**5. HARDWARE DESCRIPTION**..... 10

    5.1. HARDWARE BLOCK DIAGRAM.....10

    5.2. ANTENNA.....10

**6. ELECTRICAL CHARACTERISTICS** ..... 11

    6.1. ABSOLUTE MAXIMUM RATINGS.....11

    6.2. RECOMMENDED (OPERATING CONDITION) .....11

    6.3. DC ELECTRICAL CHARACTERISTICS .....12

    6.4. DIGITAL I/O SPECIFICATION .....12

    6.5. RF CHARACTERISTICS.....13

**7. MODULE DIMENSION** ..... 14

**8. CERTIFICATIONS** ..... 15

**9. RECOMMENDED REFLOW PROFILE** ..... 16

**10. APPLICATION NOTE** ..... 17

    10.1. SAFETY PRECAUTIONS.....17

    10.2. DESIGN ENGINEERING NOTES.....17

    10.3. STORAGE CONDITIONS .....17

    10.4. SHIPMENT .....17

    10.5. HANDLING.....18

**11. APPENDIX-A** ..... 19

    11.1. ACRONYMS & GLOSSARY.....19

List of Figures

FIGURE 1: MODULE OVERVIEW ..... 7  
FIGURE 2: MKW22D MODULE HARDWARE BLOCK DIAGRAM ..... 10  
FIGURE 3: MKW22D MODULE PHYSICAL DIMENSIONS ..... 14  
FIGURE 4: REFLOW SOLDERING PROFILE..... 16

CONFIDENTIAL

**Document Details**

**Revision History**

Rev.	Date	Description	Prepared By	Reviewed By	Approved By
0.1	24-Aug-16	Initial draft version released	Hitesh Gambhava		

**References**

Documents	Revision
MKW22D512 Datasheet - NXP	1.0

CONFIDENTIAL

### Introduction

This document describes the Volansys KW2xD512 Thread family modules which has been designed to be easily integrated into another devices and to provide fast and low cost wireless network.

The KW2xD512VH is ultra-compact, low power high sensitivity module. It is based on NXP's MKW22D512V SoC combined with Thread and ZigBee pro network stack.

No RF experience or expertise is required to add this powerful wireless networking capability to your products. This series of modules offer fast integration opportunities and the shortest possible time to market for your product.

CONFIDENTIAL

## Product Overview



The KW2xD512 is a fully self-contained, small form factor IEEE 802.15.4 thread module with low complexity and low power feature. Based on NXP's Kinetis MCU wireless hardware platform, KW2xD512 offers superior radio performance.

The KW2xD512 employs low power architecture and it has been optimized for all kind of application in home automation, smart grid, smart lighting, also networked building control and Home automation application, HVAC and security. MKW2x meets or exceeds all IEEE 802.15.4 performance specifications applicable to 2.4GHz ISM and MBAN (Medical Band Area Network) bands

KW2xD512 module complies with the FCC (part 15 B), ETSI (CE) rules applicable to the device radiating in uncontrolled environment. For evaluation and development, Volansys also offers a complete set of evaluation and development tools.

### Module Features

- Small form factor, SMT module 24mm x 19mm
- Side castellation for easy soldering and optical inspection
- Two antenna options: Integrated chip antenna or U.FL connector
- Max output power: +8dbm
- High Rx sensitivity: -102dbm
- ISM Band: 2405 MHz to 2480 MHz supported
- MBAN Band: 2360MHz to 2400MHz supported
- 32bit ARM Cortex-M4 MCU with 64K SRAM and 512K Flash
- Up to 50 MHz Cortex-M4 CPU
- Power supply range from 1.8V to 5V, support battery power application
- Extended Operation temp range: -40C to +105C
- Hardware supported encryption AES 128-bit

- Extensive low power modes (<2uA in sleep mode)
- All MCU pins accessible
- Industry standard JTAG programming and debug connectivity
- RoHS compliant
- Peripheral Interfaces: 1xSPI, 3xUART, 2xI2C, USB 2.0 FS, JTAG, 16-bit ADC, Timers

### Suggested Applications

- ZigBee SE2.0
- Smart Energy
- M2M
- Automated meter reading
- Medical Network
- HVAC Control
- Lighting control
- Asset tracking
- Environment monitoring and control

Module Pinouts

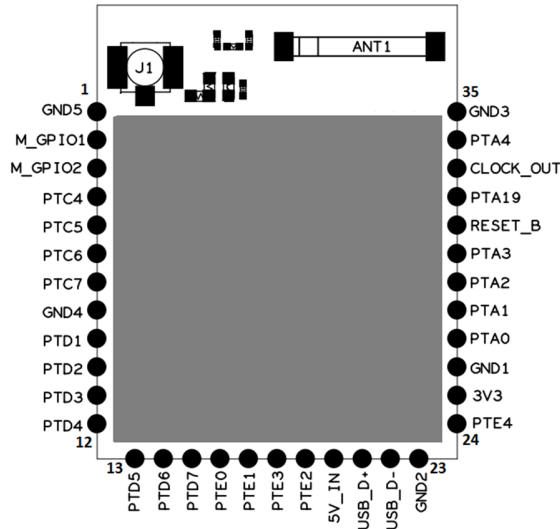

Figure 1: Module Overview

KW2xD module has 35 edge pin for connections as below:

Module PIN#	MKW22D512 PIN#	Name	Default Use	Alternate Function
1	48,51,63	GND		
2	2	M_GPIO1	GPIO1	
3	3	M_GPIO2	GPIO2	
4	4	PTC4	Disabled	SPIO_PCS0 PTC4/LLWU_P8, UART1_TX, FTMO_CH3, CMP1_OUT
5	5	PTC5	Disabled	SPIO_SCK, PTC5/LLWU_P9, LPTMR0_ALT2, I2S0_RXD0, CMPO_OUT
6	6	PTC6	CMPO_IN0	PTC6/LLWU_P10, SPIO_SOUT, PDB0_EXTRG, I2S0_RX_BCLK, I2S0_MCLK
7	7	PTC7	CMPO_IN1	PTC7, SPIO_SIN, USB_SOF_OUT, I2S_RX_FS,



8	48,51,63	GND		
9	8	PTD1	ADC0_SE5b	PTD1, SPIO_SCK, UART2_CTS_b
10	9	PTD2	Disabled	SPIO_SOUT PTD2/LLWU_P13, UART2_RX, I2C0_SCL,
11	10	PTD3	Disabled	PTD3, SPIO_SIN, UART2_TX, I2C0_SDA
12	11	PTD4	ADC0_SE21	PTD4/LLWU_P14, SPIO_PCS1, UART0_RTS_b, FTMO_CH4, EWM_IN
13	12	PTD5	ADC0_SE6b	PTD5, SPIO_PCS2, UART0_CTS_b/UART0_COL_b FTMO_CH5, EWM_OUT_b
14	13	PTD6	ADC0_SE7b	PTD6/LLWU_P15, SPIO_PCS3, UART0_RX, FTMO_CH6, FTMO_FLT0
15	14	PTD7	ADC0_SE22	PTD7, CMT_IRO, UART0_TX, FTMO_CH7, FTMO_FLT1
16	15	PTE0	ADC0_SE10	PTE0, SPI1_PCS1, UART1_TX, TRACE_CLKOUT, I2C1_SDA, RTC_CLKOUT
17	16	PTE1	DC0_SE11	PTE1/LLWU_P0, SPI1_SOUT, UART1_RX, TRACE_D3, I2C1_SCL, SPI1_SIN
18	18	PTE3	ADC0_DM1	PTE3, SPI1_SIN, UART1_RTS_b,

				TRAC E_D1, SPI1_ SOUT
19	17	PTE2	ADC0_DP1	PTE2/ LLWU_ P1, SPI1_ SCK, UART1_ CTS_ b, TRAC E_D2
20	24	5V_IN		
21	21	USB_D+	USB_D+	
22	22	USB_D-	USB_D-	
23	48,51,63	GND		
24	19	PTE4	Disabled	PTE4/ LLWU_ P2, SPI1_ PCS0, TRAC E_D0
25	20, 25, 32, 38, 42, 55	3V3		
26	48,51,63	GND		
27	33	PTA0	JTAG_TCLK/ SWD_CLK/ EZP_CLK	PTA0, UART0_ CTS_ b/UART0_ COL_ b, FTMO_ CH5,
28	34	PTA1	TAG_TDI/ EZP_DI	PTA1, UART0_ RX, FTMO_ CH6,
29	35	PTA2	JTAG_TDO/ TRACE_SWO/ EZP_DO	PTA2, UART0_ TX, FTMO_ CH7,
30	36	PTA3	JTAG_TMS/ SWD_DIO	PTA3, UART0_ RTS_ b, FTMO_ CH0,
31	41	RESET_B		
32	40	PTA19	XTAL0	PTA19, FTM1_ FLT0, FTM_ C LKIN1, LPTM RO_ AL T1
33	39	CLK_OUT/ PTA18	EXTAL0	PTA18, CLK_OUT, FTMO_ FLT2, FTM_ C LKIN0
34	37	PTA4	NMI_b/EZP_CS_b	PTA4/ LLWU_ P3, FTMO_ CH1,
35	48,51,63	GND		

**Note:**

- Either 5V\_IN or 3V3 should present at a time. 3V3 represents VDD supply.

## Hardware Description

### Hardware Block Diagram

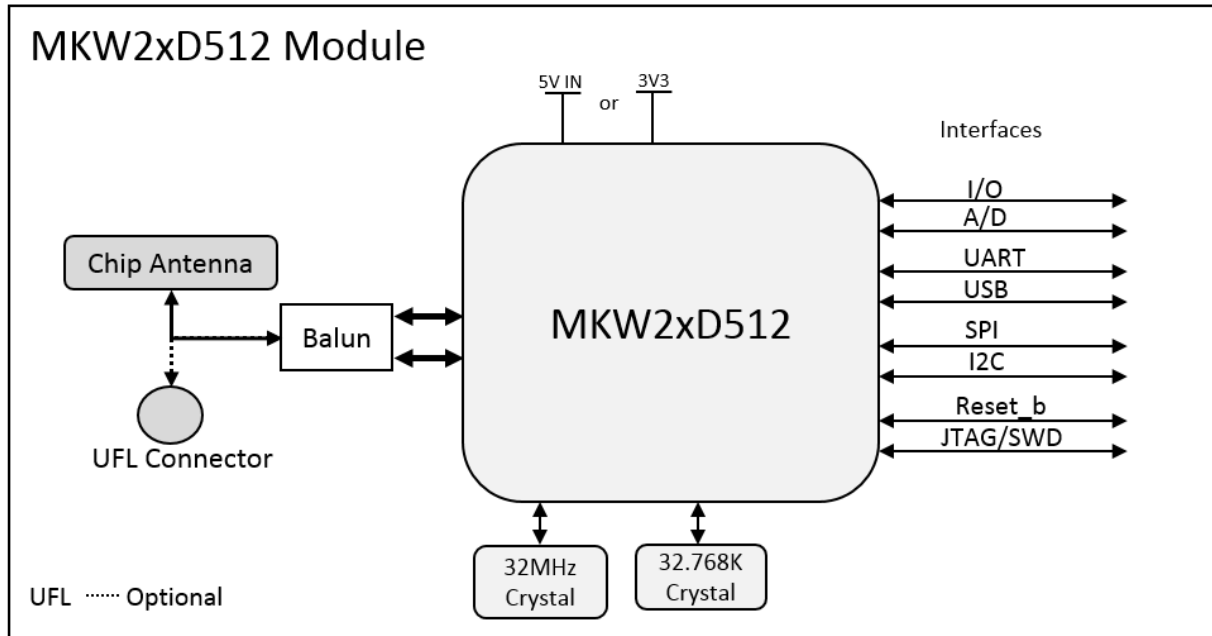

Figure 2: MKW22D Module Hardware Block Diagram

The KW2xD512 Module families are based on the NXP's Kinetis MCU family MKW22D512V. KW2xD module are fully integrated 2.4GHz IEEE 802.15.4 compliant transceiver and a powerful 32-bit ARM® Cortex M4 MCU with DSP capabilities, up to 512kB flash and 64KB SRAM memory and rich peripherals. The industry standard serial wire and JTAG programming and debugging interfaces together with the standard ARM system debug components help to streamline any custom software development.

Module has inbuilt antenna and has optional support for external antenna connection through U.FL connector. Inbuilt antenna supports ISM Band (2.4GHz) and 2.36 to 2.4 GHz Medical Band (MBAN) frequencies with same modulation as IEEE 802.15.4. The KW2xD512 modules have fully integrated 3.3V regulators for 5V USB supply. Also module can be directly powered through 3.3V instead of 5V USB. Make sure to use only one of this either two supply. Both supply should not be given to module at a time. The voltages are monitored (brown-out detection) and the built in power-on-reset circuit eliminates the need for any external monitoring circuitry. An RTC 32.768 kHz watch crystal is also internally connected.

### Antenna

The KW2xD Module includes an integrated chip antenna. An optional U.FL connector can be specified, providing connection to a 50-ohm external antenna of the user's choice. However, use of an external antenna is not covered by the module's certification; For optimum antenna performance, the KW2xD Module should be mounted with the PCB chip antenna overhanging the edge of the host board. To further improve performance, a ground plane may be placed on the host board under the module up to the

antenna keep out area. The installation of an uninterrupted ground plane on a layer directly beneath the module will also allow you to run traces under this layer.

The chip antenna is compact and highly efficient. To maximize range, an adequate ground plane must be provided on the host PCB. Correctly positioned, the ground plane on the host PCB will contribute significantly to the antenna performance; it should not be directly under the chip antenna. The position of the module on the host board and overall design of the product enclosure contribute to antenna performance. Poor design affects radiation patterns and can result in reflection, diffraction and/or scattering of the transmitted signal.

A few design guidelines to help ensure antenna performance:

- Never place the ground plane or route copper traces directly underneath the antenna portion of the module
- Never place the antenna close to metallic objects
- In the overall design, ensure that wiring and other components are not placed near the antenna
- Do not place the antenna in a metallic or metalized plastic enclosure
- Keep plastic enclosures 1cm or more away from the antenna in any direction

## Electrical characteristics

### Absolute Maximum Ratings

The absolute maximum ratings given below should under no circumstances be violated. Exceeding one or more of the limiting values may cause permanent damage to the device.

Description	Module		Unit
	Min	Max	
Power supply voltage (VDD)	-0.3	3.6	V
Voltage on I/O line	-0.3	VDD+0.3	V
RF Input power	-	+10	dbm
Storage temperature	-40	85	°C

### Recommended (Operating Condition)

Description	Module			Unit
	Min	Typ	Max	
Power supply voltage (VDD)	1.8	3.3	3.6	V
RF Input Frequency	2360		2480	MHz
RF Input Power	-	-	10	dBm
SPI Clock Rate	-	-	16.0	MHz
Input High voltage <ul style="list-style-type: none"> <li>• <math>2.7V \leq VDD \leq 3.6V</math></li> <li>• <math>1.7V \leq VDD \leq 2.7V</math></li> </ul>	0.7V x VDD 0.75V x VDD	-	-	V
Input Low voltage <ul style="list-style-type: none"> <li>• <math>2.7V \leq VDD \leq 3.6V</math></li> </ul>	-	-	0.35V x VDD	V

• $1.7V \leq VDD \leq 2.7V$			0.3V x VDD	
Ambient temperature	-10	25	85	°C

**Note:**

- Analog supply voltage is same as VDD = 3.3V (Typical)
- RF Input Frequency includes ISM and MBAN bands.

DC Electrical Characteristics

VDD = 3.3V, Tamb = 25°C, unless otherwise Specified

Description	Module			Unit
	Min	Typ	Max	
Transmit mode current, +8dBm	-	TBD	-	mA
Receive mode current	-	TBD	-	mA
Idle mode	-	TBD	-	mA
Sleep/Reset/Power down mode current	-	TBD	-	uA

**Please Note:**

- The average current consumption during operation is dependent on the firmware and the network load.

Digital I/O Specification

Digital I/Os of KW2xD512 Module,

VDD = 3.3V, Tamb = 25°C, unless otherwise Specified

Symbol	Description	Module			Unit
		Min	Typ	Max	
VOH	Output high voltage — high drive strength • $2.7V \leq VDD \leq 3.6V$ , IOH = - 9 mA • $1.71V \leq VDD \leq 2.7V$ , IOH = -3 mA	VDD-0.5	-	-	V
	Output high voltage — low drive strength • $2.7V \leq VDD \leq 3.6V$ , IOH = -2 mA • $1.71V \leq VDD \leq 2.7V$ , IOH = -0.6 mA	VDD-0.5	-	-	V
IOHT	IOHT Output high current total for all ports	-	-	100	mA
VOL	Output low voltage — high drive strength • $2.7V \leq VDD \leq 3.6V$ , IOL = 9 mA • $1.71V \leq VDD \leq 2.7V$ , IOL = 3 mA	-	-	0.5	V
	Output low voltage — low drive strength • $2.7V \leq VDD \leq 3.6V$ , IOL = 2 mA • $1.71V \leq VDD \leq 2.7V$ , IOL = 0.6 mA	-	-	0.5	V
VOLT	IOLT Output low current total for all ports	-	-	100	mA
RESET_b	Reset Pulse width to guarantee a reset	100	-	-	ns

RF Characteristics

Description	Module			Unit
	Min	Typ	Max	
RF Frequency range	2.360	-	2.480	GHz
RF Channels (IEEE 802.15.4)	11	-	26	-
Channel Spacing		5		MHz
Tx Power	-35	-	8	dBm
Rx Sensitivity	-	-102	-	dBm

CONFIDENTIAL

## Module Dimension

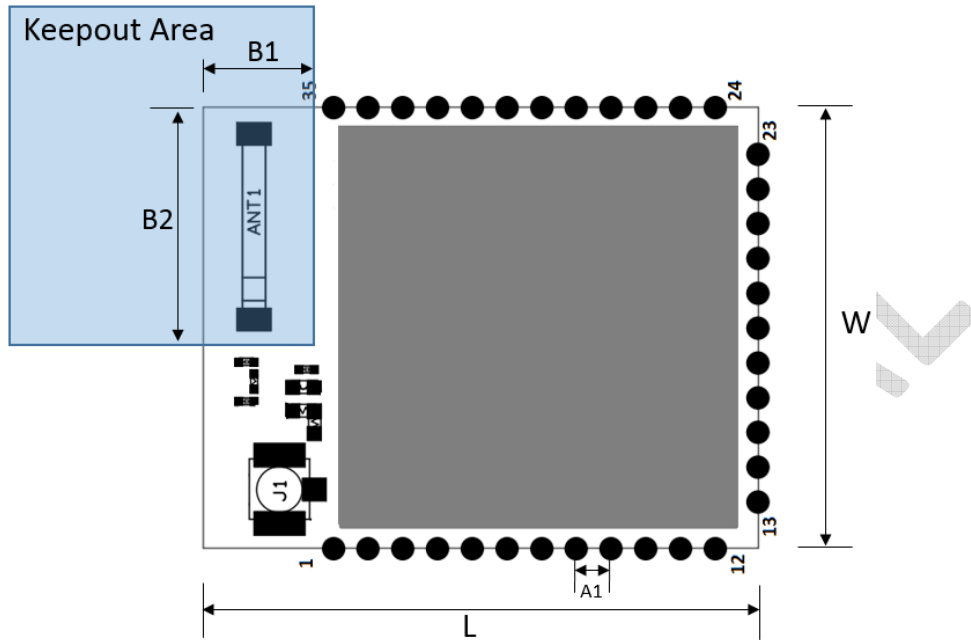

Figure 3: MKW22D Module Physical Dimensions

Symbol	Description	Typical Distance
L	Length of Module	24mm
W	Width of Modules	19mm
A1	Castellated holes pitch	1.5mm
B1	Keepout zone from corner of PCB	4mm
B2	Keepout zone from corner of PCB	11mm

For ideal RF performance when using the on-board antenna, the antenna should be located at the corner of the carrier PCB. There should be no components, tracks or copper planes in the Keepout area which should be as large as possible. When using the U.FL RF connector the keep-out area does not have to be obeyed. Note: The modules transmit/receive range will depend on the antenna used and also the housing of the finished product.

When placing the module please either locate the antenna in the corner edge of PCB. So that the recommended antenna keep out zone is being followed, or add a no copper zone as mentioned keep out area.

Certifications

<TBD>

CONFIDENTIAL



## Recommended Reflow Profile

### Recommended Reflow Profile

Parameters Values	
Ramp Up Rate (from T soak max to T peak)	3°/sec max
Minimum Soak Temperature	150°C
Maximum Soak Temperature	200°C
Soak Time	90 ±30 sec
T Liquids	220°C
Time above TL	60-150 sec
T peak	250°C
Time within 5° of T peak	20-30 sec
Time from 25° to T peak	8 min max
Ramp Down Rate	6°C/sec max

Figure 4: Reflow Soldering Profile

Use of “No-Clean” solder paste is recommended to avoid the requirement for a cleaning process. Cleaning the module is strongly discouraged because it will be difficult to ensure no cleaning agent and other residuals are remaining underneath the shielding can as well as in the gap between the module and the host board.

**Please Note:**

Maximum number of reflow cycles: 2

Opposite-side reflow is prohibited: Do not place the module on the bottom / underside of your PCB and re-flow

## Application Note

### Safety Precautions

These specifications are intended to preserve the quality assurance of products as individual components. Before use, check and evaluate the module's operation when mounted on your products. Abide by these specifications when using the products. These products may short-circuit. If electrical shocks, smoke, fire, and/or accidents involving human life are anticipated when a short circuit occurs, then provide the following failsafe functions as a minimum:

- (1) Ensure the safety of the whole system by installing a protection circuit and a protection device.
- (2) Ensure the safety of the whole system by installing a redundant circuit or another system to prevent a single fault causing an unsafe status.

### Design Engineering Notes

- (1) Heat is the major cause of shortening the life of the modules. Avoid assembly and use of the target equipment in conditions where the product's temperature may exceed the maximum allowable.
- (2) Failure to do so may result in degrading of the product's functions and damage to the product.
- (3) If pulses or other transient loads (a large load applied in a short time) are applied to the products, before use, check and evaluate their operation when assembled onto your products.
- (4) These products are not intended for other uses, other than under the special conditions shown below. Before using these products under such special conditions, check their performance and reliability under the said special conditions carefully, to determine whether or not they can be used in such a manner.
- (5) In liquid, such as water, salt water, oil, alkali, or organic solvent, or in places where liquid may splash. In direct sunlight, outdoors, or in a dusty environment. In an environment where condensation occurs. In an environment with a high concentration of harmful gas (ex. salty air, HCl, Cl<sub>2</sub>, SO<sub>2</sub>, H<sub>2</sub>S, NH<sub>3</sub>, and NO<sub>x</sub>)
- (6) If an abnormal voltage is applied due to a problem occurring in other components or circuits, replace these products with new products because they may not be able to provide normal performance even if their electronic characteristics and appearances appear satisfactory.
- (7) Mechanical stress during assembly of the board and operation has to be avoided.
- (8) Pressing on parts of the metal cover or fastening objects to the metal cover is not permitted.

### Storage Conditions

- (1) The module must not be stressed mechanically during storage.
- (2) Do not store these products in the following conditions or the performance characteristics of the product, such as RF performance, may well be adversely affected:
- (3) Storage in salty air or in an environment with a high concentration of corrosive gas, such as Cl<sub>2</sub>, H<sub>2</sub>S, NH<sub>3</sub>, SO<sub>2</sub>, or NO<sub>x</sub>
- (4) Storage (before assembly of the end product) of the modules for more than one year after the date of delivery at your company even if all the above conditions (1) to (3) have been met, should be avoided.

### Shipment

The KW2xD Modules are delivered in trays of **TBD**.

**Handling**

<TBD> The KW2xD Modules are designed and packaged to be processed in an automated assembly line.

CONFIDENTIAL

## Appendix-A

### Acronyms & Glossary

The following terms are used in this document

Sr No#	Terms	Definition
1.	MCU	Microcontroller Unit
2.	CPU	Central Processing Unit
3.	U.FL	Ultra-Miniature RF Connector
4.	BLE	Bluetooth Low Energy
5.	PWM	Pulse width Modulation
6.	ADC	Analog to Digital Convertor
7.	TBD	To Be Define
8.	MCU	Micro Controller Unit
9.	SRAM	Static Random Access Memory
10.	RTC	Real Time Clock