

CYPRESS F-RAM™ SOLUTIONS

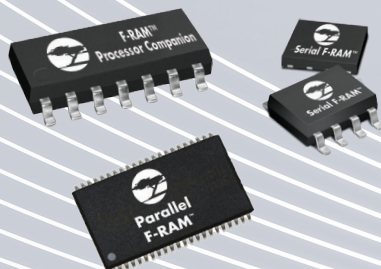

THE TRUSTED LEADER FOR INSTANT
DATA CAPTURE AND PROTECTION



THE INDUSTRY'S BEST MISSION-CRITICAL MEMORIES

Cypress is the trusted global leader for instant data capture and protection with the broadest portfolio of nonvolatile random access memory (NVRAM) devices, 25 years of experience and more than one billion devices shipped. Cypress's nonvolatile RAMs are used in mission-critical systems to instantly capture and preserve critical data when power is interrupted, with fast read and write capabilities.

Cypress offers two types of nonvolatile RAMs: nvSRAM (nonvolatile SRAM) and F-RAM (ferroelectric RAM). Cypress's F-RAMs have three distinct advantages over traditional nonvolatile memories: high speed, high endurance and energy efficiency. Cypress also offers F-RAMs with integrated processor companion features, such as Real-Time Clock (RTC) and Early Power-Fail Warning.

Key F-RAM applications include smart meters, automotive electronics, industrial control and automation equipment, multifunction printers and portable medical devices.

F-RAM TECHNOLOGY AND BENEFITS

Nonvolatile – The F-RAM memory cell contains a thin ferroelectric film of lead zirconate titanate, commonly referred to as PZT (Figure 1). The central atom in the PZT crystal unit cell changes position when an electric field is applied. The two positions of the central atom are used as binary states for the memory logic to store one bit. When power is interrupted, the atom's position is retained, protecting the data.

Fast Write – F-RAMs write data instantly to nonvolatile memory cells at bus speed. Competing memories, such as EEPROM, have a typical write delay of 5 ms. Fast write is critical in smart meters, automotive electronics, industrial control equipment, multifunction printers and portable medical devices.

High Endurance – Cypress's F-RAMs offer 100 trillion (10^{14}) write cycles, meaning they will far outlast other nonvolatile memory devices. Floating gate devices, such as Flash or EEPROM, wear out in as few as one-hundred thousand (10^5) cycles, making them unsuitable for write-intensive applications.

FIGURE 1: HOW F-RAMS WORK

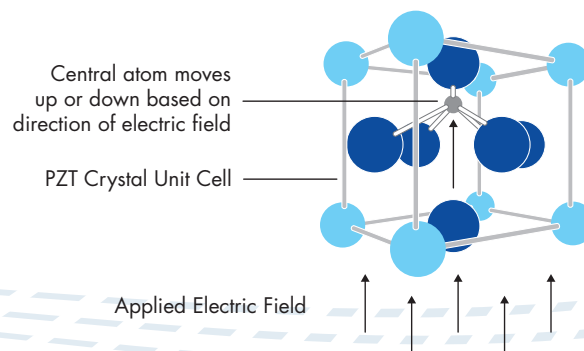

CYPRESS F-RAM BENEFITS

Energy Efficient – Cypress’s F-RAMs consume 200x less energy than serial EEPROM and 3,000x less energy than NOR Flash.

Radiation and EMI Tolerant – Cypress’s FRAM cells are immune to soft errors caused by gamma rays, x-rays, alpha particles, and other sources that can produce bit flips in memory devices. This feature makes Cypress’s F-RAMs an ideal choice for space applications and sterilized medical applications. Ferroelectric crystals are not ferromagnetic and therefore are not influenced by magnetic fields.

Simple Design – Cypress’s serial F-RAMs are pin-for-pin compatible with serial EEPROMs and its parallel F-RAMs are pin-for-pin compatible with parallel SRAMs. Cypress’s F-RAMs also provide instant nonvolatility and have virtually unlimited write endurance without the need for wear-leveling software required by competing EEPROM and Flash devices.

DATA PROTECTION

Cypress’s F-RAMs protect data in a wide array of mission-critical applications.

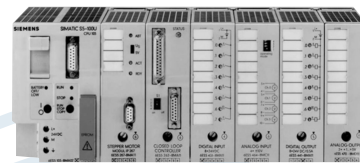

PROGRAMMABLE LOGIC CONTROLLERS



AUTOMOTIVE INFOTAINMENT SYSTEMS



SMART E-METERS



DIGITAL HEARING AIDS



MULTIFUNCTION PRINTERS

SERIAL F-RAM

Cypress's serial F-RAM products provide reliable data collection, perform reads and writes like a RAM and eliminate the complexities, overhead and system reliability problems of EEPROMs. F-RAM is an ideal solution for systems that require the nonvolatile data retention of a ROM for code storage and the high speed and high endurance of a RAM for data storage. Serial F-RAMs are ideal for mission-critical applications such as smart meters, automotive electronics, industrial control and automation equipment, multifunction printers and portable medical devices.

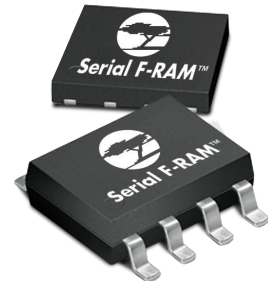

BASELINE ARCHITECTURE

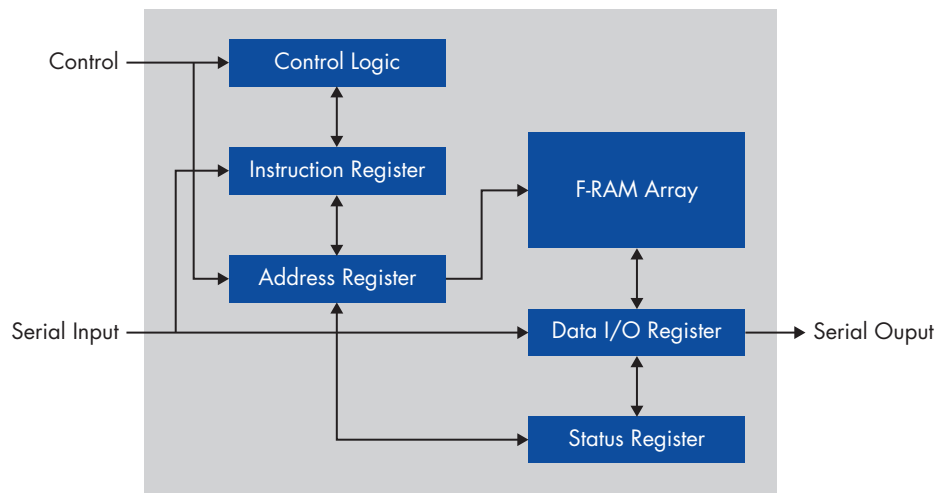

SERIAL I²C PRODUCT SELECTOR GUIDE

Part Number	Density	Max. Frequency	Voltage Range	Temp. Range	Package	AEC-Q100	Status
FM24V10	1Mb	3.4 MHz	2.0-3.6 V	-40°C to +85°C	SOIC8	Grade 3	Production
FM24VN10	1Mb	3.4 MHz	2.0-3.6 V	-40°C to +85°C	SOIC8	Grade 3	Production
FM24V05	512Kb	3.4 MHz	2.0-3.6 V	-40°C to +85°C	SOIC8	Grade 3	Production
CY15B256J-SXA	256Kb	3.4 MHz	2.0-3.6 V	-40°C to 85°C	SOIC8	Grade 3	Production
FM24V02A	256Kb	3.4 MHz	2.0-3.6 V	-40°C to +85°C	SOIC8		Production
FM24W256	256Kb	1 MHz	2.7-5.5 V	-40°C to +85°C	SOIC8	Grade 3	Production
CY15B128J-SXA	128Kb	3.4 MHz	2.0-3.6 V	-40°C to 85°C	SOIC8	Grade 3	Production
FM24V01A	128Kb	3.4 MHz	2.0-3.6 V	-40°C to +85°C	SOIC8		Production
FM24C64B	64Kb	1 MHz	4.5-5.5 V	-40°C to +85°C	SOIC8	Grade 3	Production
FM24CL64B	64Kb	1 MHz	2.7-3.6 V	-40°C to +85°C	SOIC8, TDFN8	Grade 3	Production
FM24CL64B-GA	64Kb	1 MHz	2.7-3.6 V	-40°C to +125°C	SOIC8	Grade 1	Production
FM24C16B	16Kb	1 MHz	4.5-5.5 V	-40°C to +85°C	SOIC8	Grade 3	Production
FM24CL16B	16Kb	1 MHz	2.7-3.65 V	-40°C to +85°C	SOIC8, TDFN8	Grade 3	Production
FM24C04B	4Kb	1 MHz	4.5-5.5 V	-40°C to +85°C	SOIC8	Grade 3	Production
FM24CL04B	4Kb	1 MHz	2.7-3.65 V	-40°C to +85°C	SOIC8	Grade 3	Production

SERIAL SPI PRODUCT SELECTOR GUIDE

Part Number	Density	Max. Frequency	Voltage Range	Temp. Range	Package	AEC-Q100	Status
CY15B104Q	4Mb	40 MHz	2.0-3.6 V	-40°C to +85°C	EIAJ8, TDFN8		Contact Sales
CY15B102Q	2Mb	25MHz	2.0-3.6 V	-40°C to +125°C	SOIC8	Grade 1	Production
FM25V20A	2Mb	40 MHz	2.0-3.6 V	-40°C to +85°C -40°C to +105°C	EIAJ8, TDFN8		Production
FM25V10	1Mb	40 MHz	2.0-3.6 V	-40°C to +85°C	SOIC8	Grade 3	Production
FM25VN10	1Mb	40 MHz	2.0-3.6 V	-40°C to +85°C	SOIC8	Grade 3	Production
FM25V05	512Kb	40 MHz	2.0-3.6 V	-40°C to +85°C	SOIC8	Grade 3	Production
CY15B256Q-SXA	256Kb	40 MHz	2.0-3.6 V	-40°C to 85°C	SOIC8	Grade 3	Production
FM25V02A	256Kb	40 MHz	2.0-3.6 V	-40°C to +85°C -40°C to +105°C	SOIC8, TDFN8		Production
FM25W256	256Kb	20 MHz	2.7-5.5 V	-40°C to +85°C	SOIC8	Grade 3	Production
CY15B128Q-SXA	128Kb	40 MHz	2.0-3.6 V	-40°C to 85°C	SOIC8	Grade 3	Production
FM25V01A	128Kb	40 MHz	2.0-3.6 V	-40°C to +85°C	SOIC8		Production
FM25640B	64Kb	20 MHz	4.5-5.5 V	-40°C to +85°C	SOIC8	Grade 3	Production
FM25CL64B	64Kb	20 MHz	2.7-3.65 V	-40°C to +85°C	SOIC8, TDFN8	Grade 3	Production
FM25CL64B-GA	64Kb	16 MHz	3.0-3.6 V	-40°C to +125°C	SOIC8	Grade 1	Production
FM25C160B	16Kb	20 MHz	4.5-5.5 V	-40°C to +85°C	SOIC8	Grade 3	Production
FM25C160B-GA	16Kb	15 MHz	4.5-5.5 V	-40°C to +125°C	SOIC8	Grade 1	Production
FM25L16B	16Kb	20 MHz	2.7-3.6 V	-40°C to +85°C	SOIC8, TDFN8	Grade 3	Production
FM25040B	4Kb	20 MHz	4.5-5.5 V	-40°C to +85°C	SOIC8	Grade 3	Production
FM25040B-GA	4Kb	14 MHz	4.5-5.5 V	-40°C to +125°C	SOIC8	Grade 1	Production
FM25L04B	4Kb	20 MHz	2.7-3.6 V	-40°C to +85°C	SOIC8, TDFN8	Grade 3	Production
FM25L04B-GA	4Kb	10 MHz	3.0-3.6 V	-40°C to +125°C	SOIC8	Grade 1	Production

* For special product requests, including wafer sales, automotive qualifications, or extended temperature ranges, please contact: cypressFRAM@cypress.com

PARALLEL F-RAM

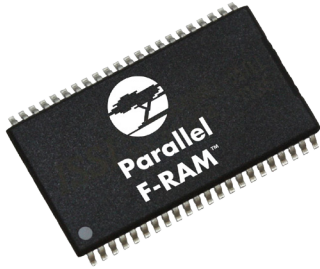

Cypress's parallel F-RAM products offer high-reliability reads and writes and provide instant nonvolatile data retention on power loss without the need for a battery or capacitor. In addition, customers benefit from the soft error rate immunity of Cypress's parallel F-RAM products. Parallel F-RAMs are ideal for applications that require high-reliability and high-endurance memory such as programmable logic controllers.

BASELINE ARCHITECTURE

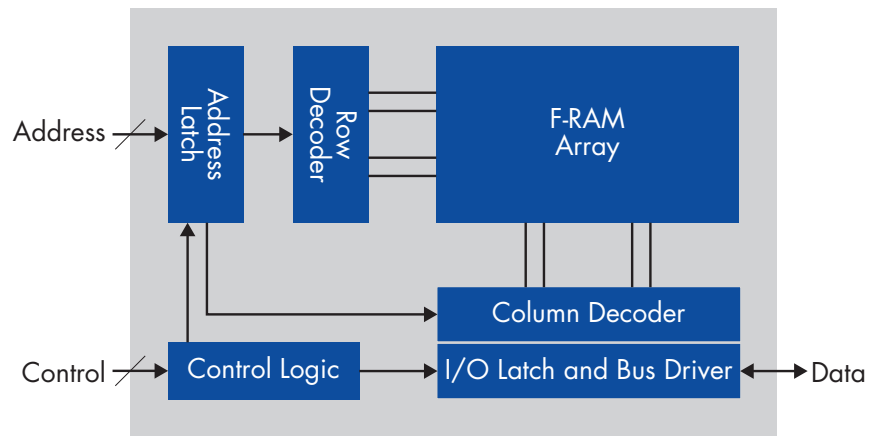

PARALLEL PRODUCT SELECTOR GUIDE

Part Number	Density	Organization	Access Time	Voltage Range	Temp. Range	Package	AEC-Q100	Status
FM22L16	4Mb	256k x 16	55 ns	2.7-3.6 V	-40°C to +85°C	TSOPII-44		Production
FM22LD16	4Mb	256k x 16	55 ns	2.7-3.6 V	-40°C to +85°C	FBGA-48		Production
CY15B102N	2Mb	128k x 16	60 ns	2.0-3.6 V	-40°C to +85°C	TSOPII-44	Grade 3	Production
FM28V202A	2Mb	128k x 16	60 ns	2.0-3.6 V	-40°C to +85°C	TSOPII-44		Production
CY15B101N	1Mb	64k x 16	60 ns	2.0-3.6 V	-40°C to +85°C	TSOPII-44	Grade 3	Production
FM28V102A	1Mb	64k x 16	60 ns	2.0-3.6 V	-40°C to +85°C	TSOPII-44		Production
FM1808B	256Kb	32k x 8	70 ns	4.5-5.5 V	-40°C to +85°C	SOIC-28		Production
FM18W08	256Kb	32k x 8	70 ns	2.7-5.5 V	-40°C to +85°C	SOIC-28		Production
FM28V020	256Kb	32k x 8	70 ns	2.0-3.6 V	-40°C to +85°C	TSOPI-32		Production
FM16W08	64Kb	8k x 8	70 ns	2.7-5.5 V	-40°C to +85°C	SOIC-28		Production

* For special product requests, including wafer sales, automotive qualifications, or extended temperature ranges, please contact: cypressFRAM@cypress.com

F-RAM PROCESSOR COMPANIONS

Cypress's F-RAM Processor Companions offer integrated analog and digital functions for processor-based systems. These devices offer F-RAM memory along with a Real-Time Clock (RTC), low-V_{DD} reset, a watchdog timer, a battery-backed event counter, an event-driven interrupt output, a lockable 64-bit serial number and early power-fail interrupt. Processor Companions are used to offload the processor or controller tasks in applications like smart meters.

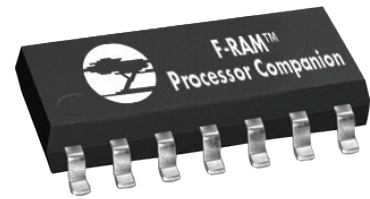

BASELINE ARCHITECTURE

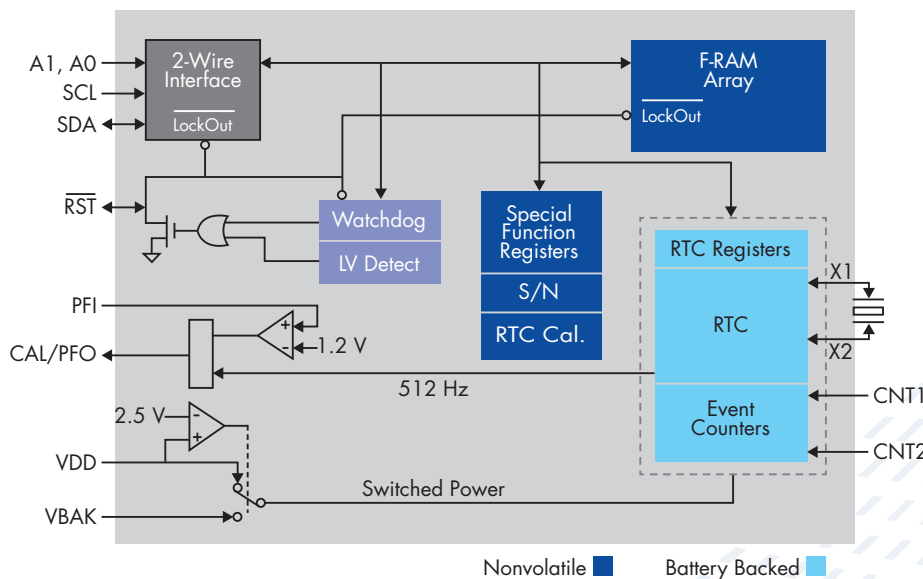

PROCESSOR COMPANION PRODUCT SELECTOR GUIDE

Part Number	Density	Interface	RTC (Y/N)	RTC Alarm (Y/N)	Early P/F (Y/N)	Battery Switch Over (Y/N)	Event Detect	Power Monitor (Y/N)	Serial Number (Y/N)	Watchdog (Y/N)	Voltage Range	Temp. Range	Package	Status
FM31256	256Kb	I ² C	Y	N	Y	Y	Count	Y	Y	Y	2.7-5.5 V	-40°C to +85°C	SOIC14	Production
FM31278	256Kb	I ² C	Y	N	Y	Y	Count	Y	Y	Y	4.0-5.5 V	-40°C to +85°C	SOIC14	Production
FM31L278	256Kb	I ² C	Y	N	Y	Y	Count	Y	Y	Y	2.7-3.6 V	-40°C to +85°C	SOIC14	Production
FM31276	64Kb	I ² C	Y	N	Y	Y	Count	Y	Y	Y	4.0-5.5 V	-40°C to +85°C	SOIC14	Production
FM3164	64Kb	I ² C	Y	N	Y	Y	Count	Y	Y	Y	2.7-5.5 V	-40°C to +85°C	SOIC14	Production
FM31L276	64Kb	I ² C	Y	N	Y	Y	Count	Y	Y	Y	2.7-3.6 V	-40°C to +85°C	SOIC14	Production
FM33256B	256Kb	SPI	Y	Y	Y	Y	Count	Y	Y	Y	2.7-3.6 V	-40°C to +85°C	SOIC14	Production

CONTACT US

CYPRESS HEADQUARTERS

198 Champion Court
San Jose, CA 95134 USA
Tel: +1 (408) 943-2600
Fax: +1 (408) 943-6848
Toll-free: +1 (800) 858-1810 (U.S. only)

www.cypress.com

www.cypress.com/go/training

CYPRESS EDUCATION— UNIVERSITY ALLIANCE

www.cypress.com/university

ONLINE TECHNICAL SUPPORT

www.cypress.com/support

CYPROS® CERTIFIED CONSULTANTS

www.cypress.com/cypros

CYPRESS ONLINE STORE

www.cypress.com/buyonline

44-pin TSOP-II

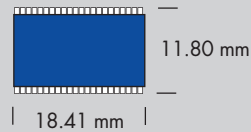

32-pin TSOP-I

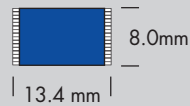

28-pin SOIC

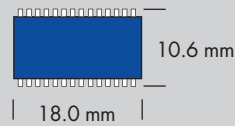

14-pin SOIC

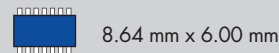

8-pin SOIC

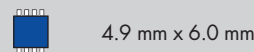

8-pin EIAJ

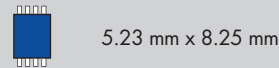

48-pin FBGA

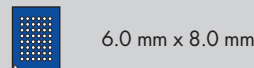

8-pin TDFN

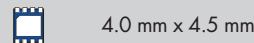

8-pin TDFN

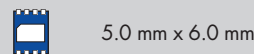

PACKAGE DIMENSIONS

Package dimensions are shown as typical measurements and are intended for quick reference only. Please refer to detailed product datasheets for precise package dimensions and complete specifications.

FOR MORE INFORMATION

For more information on F-RAM solutions or to order samples:

www.cypress.com/nonvolatile



Contact: CypressFRAM@cypress.com