

Module LoRaWAN-EU868

SKU:M148

MODULE
LoRaWAN-EU868

M5STACK

ANTENNA



SMA

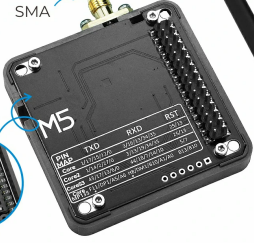

EU868
STM32WLE5
LoRaWAN / P2P

UART
INTERFACE
COMPATIBLE & NOT INCLUDED



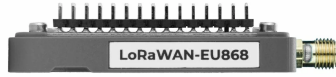

Description

Module LoRaWAN-EU868 is a long-range, low-power wireless communication module based on LoRa modulation technology, designed for long-distance, low-power IoT application scenarios. The module adopts the RAK3172-8-SM-I (built-in STM32WLE5) core solution, featuring long-distance transmission, low power consumption, and high receiving sensitivity. Developed for the **EU868 frequency band**, it complies with European radio frequency regulations and is suitable for the EU and regions adopting the EU868 band. The module integrates a complete LoRaWAN protocol stack, supporting three operating modes: Class A/Class B/Class C, and is also compatible with point-to-point (P2P) communication. It supports low-power sleep to meet the requirements of long-endurance terminals.

Hardware-integrated DIP switches allow flexible switching of UART communication pins to adapt to different main control platform pin assignments. The module is controlled via standard AT commands and supports multi-module stacking for easy function expansion. Equipped with a high-performance rubber duck antenna, it improves signal stability, coverage, and communication distance, adapting to complex industrial and outdoor environments. This module can act as a collection node connected to a LoRaWAN gateway for data acquisition and remote management; it can also achieve direct device-to-device communication in P2P mode without a gateway. Typical applications include smart agriculture, industrial monitoring, environmental monitoring, and other long-range low-power IoT communication scenarios.

Features

- Compliant with LoRaWAN 1.0.3 protocol
- Supports EU868 frequency band
- Supports LoRa P2P (Point-to-Point) communication

- LoRaWAN activation modes: OTAA, ABP
- UART communication (AT commands)
- High-sensitivity rubber duck antenna
- Low power consumption
- Development Platform
 - UiFlow2
 - Arduino IDE

| Includes

- 1 x Module LoRaWAN-EU868
- 1 x Rubber Duck Antenna

| Applications

- Smart Agriculture
- Industrial Monitoring
- Environmental Monitoring Node Deployment

| Specifications

Specification	Parameter
LoRa Solution	STM32WLE5 @256 KB Flash, 64 KB RAM
Supported Frequency Band	EU868 (863 ~ 870 MHz)
Protocol Support	LoRaWAN 1.0.3 protocol (Class A/Class B/Class C)
Receiving Sensitivity	-137 dBm
Transmit Power	Max. 19 dBm
LoRaWAN Activation Modes	OTAA, ABP
Communication Mode	LoRaWAN and Point-to-Point (P2P)
Interface Type	UART @ 115200bps, supports AT commands
Antenna Specification	Size 198 x 13mm, interface SMA (female inner pin), operating band 863 ~ 870 MHz, gain 2.8dBi, VSWR ≤ 1.3
Standby Power Consumption	Standby: DC 5V@6.70mA Sleep: DC 5V@9uA or 3.3V@3.69uA
Operating Current	P2P mode receiving data (BW 125K): 5V@8.27mA P2P mode continuous transmission (BW 125K): 5V@80.38mA
Operating Temperature	0 ~ 40°C
Product Size	54.0 x 63.6 x 7.6mm
Product Weight	16.1g
Package Size	134.0 x 95.0 x 15.7mm
Gross Weight	54.2g

Learn

Operating Mode Description

Comparison of LoRaWAN Operating Modes

Mode	Downlink Real-Time Performance	Power Consumption	Application Scenarios
Class A	Lowest	Lowest	Periodic data upload, low-power sensors
Class B	Medium	Medium	Timed control devices
Class C	Highest	Highest	Real-time control devices such as industrial automation

Certifications

- o [RAK3172 Module Certification Information](#)

Schematics

- o [Module LoRaWAN-EU868 Schematics PDF](#)

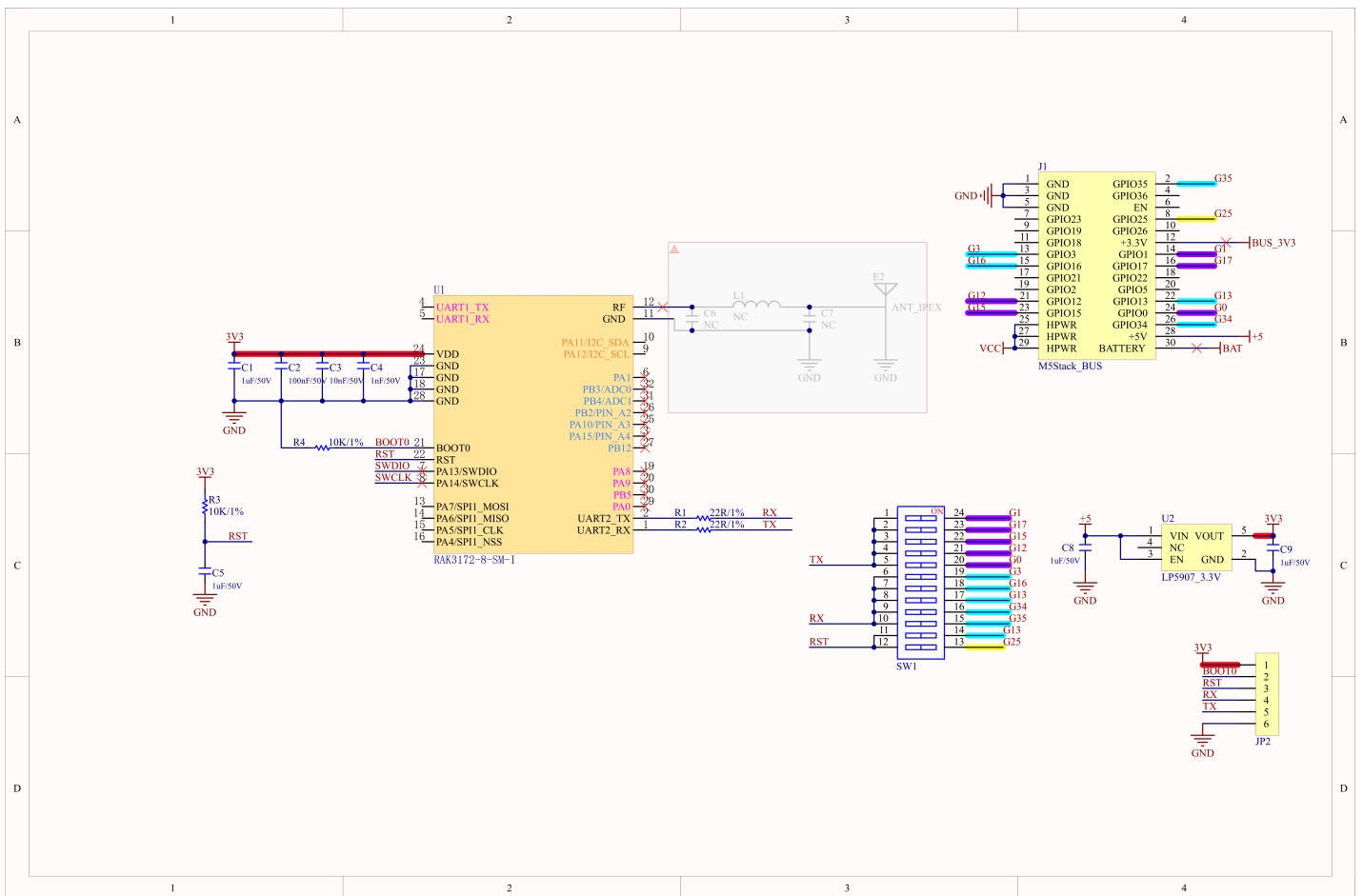

PinMap

M5-Bus

DIP Switch

Pins marked **SW** in the M5-Bus below can be switched via DIP switches to adapt to different main controllers.

PIN	LEFT	RIGHT	PIN
GND	1	2	RX (SW)
GND	3	4	
GND	5	6	
	7	8	RST (SW)
	9	10	
	11	12	
RX (SW)	13	14	TX (SW)
RX (SW)	15	16	TX (SW)
	17	18	
	19	20	
TX (SW)	21	22	RST/RX (SW)
TX (SW)	23	24	TX (SW)
HPWR	25	26	RX (SW)
HPWR	27	28	5V
HPWR	29	30	

Model Size

- [Module LoRaWAN-EU868 Model Size PDF](#)

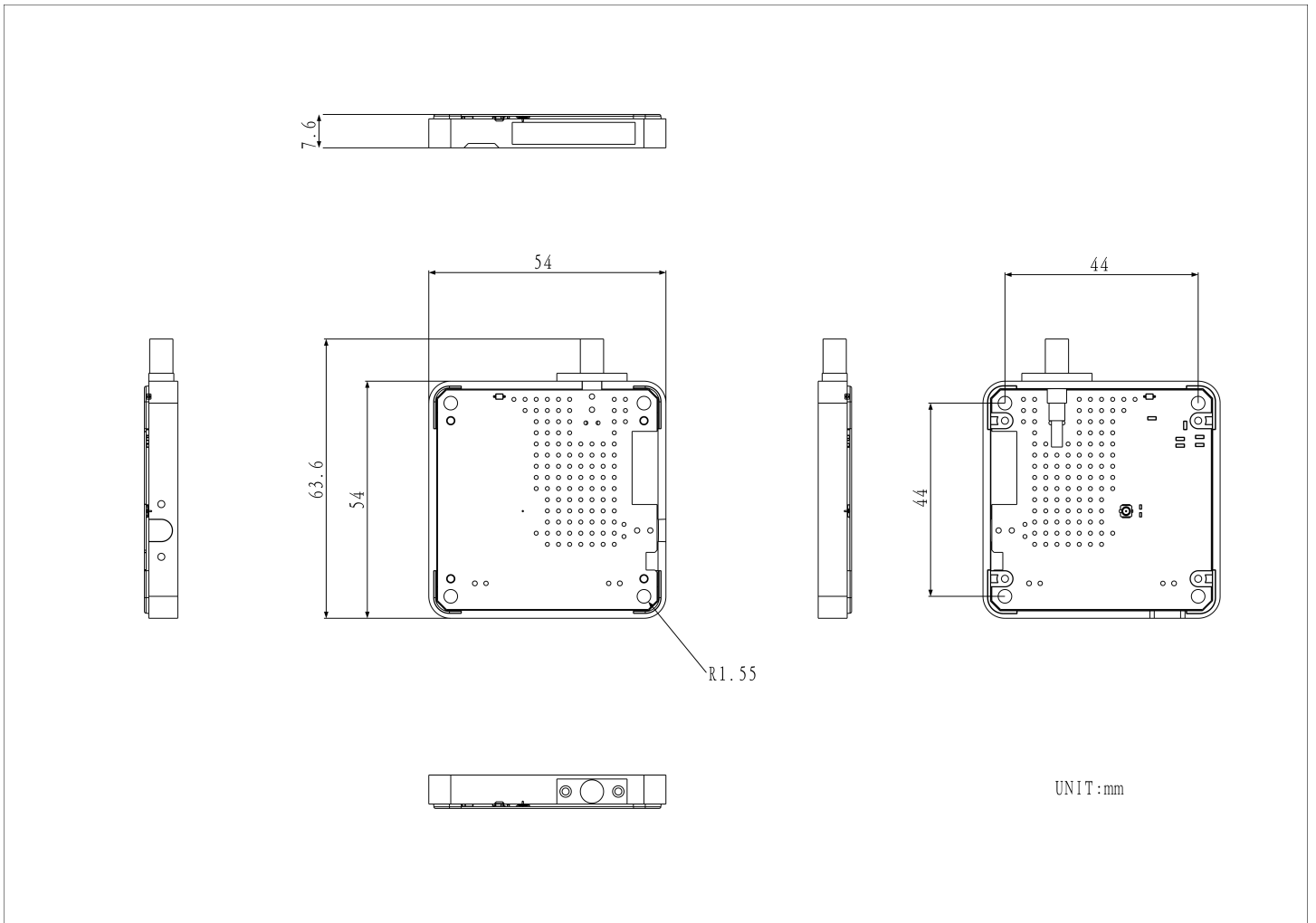

Datasheets

- [RAK3172 Datasheet](#)

Softwares

Arduino

- [Module LoRaWAN-EU868 Arduino Library](#)

Protocol

- [Module LoRaWAN-EU868 AT Command Manual](#)

Video

- [Module LoRaWAN-EU868 Product Introduction](#)

[M148-Module-LORWAN-EU868-video-EN.mp4](#)