

ISL32613E, ISL32614E

±16.5kV ESD Protected, +125°C, 1.8V to 3.6V, Low Power, SOT-23, RS-485/RS-422 Transmitters

FN7906
Rev 2.00
July 27, 2015

The Intersil [ISL32613E](#) and [ISL32614E](#) are ±16.5kV HBM ESD Protected (7kV IEC61000 contact), 1.8V powered, single transmitters for differential communication. These drivers have very low bus currents (±40µA), so they present less than a “1/8 unit load” to the bus. This allows more than 256 transmitters on the network, without violating the RS-485 specification’s 32 unit load maximum and without using repeaters.

Hot Plug circuitry ensures that the Tx outputs remain in a high impedance state while the power supply stabilizes.

Both ICs utilize slew rate limited drivers, which reduce EMI and minimize reflections from improperly terminated transmission lines or unterminated stubs in multidrop and multipoint applications. The ISL32613E is more slew rate limited for data rates up to 128kbps, while the less limited ISL32614E is useful for data rates up to 256kbps.

For companion low power single RS-485 receivers, please see the [ISL32610E](#) datasheet.

Features

- Wide supply voltage range 1.8V to 3.6V
- Low quiescent supply current. 80µA (max)
 - Very low shutdown supply current 2µA (max)
- High ESD protection on RS-485 outputs ±16.5kV HBM
 - Class 3 ESD level on all other pins. >8kV HBM
- Specified for +125°C or full military temperature range
- Hot Plug - Tx outputs remain three-state during power-up
- Low Tx leakage allows >256 devices on the bus
- Slew rate limited for data rates up to 256kbps
- Current limiting and thermal shutdown for driver overload protection
- 5V tolerant logic inputs
- Pb-Free (RoHS Compliant)

Applications

- Industrial/process control networks
- Space-constrained systems
- Factory automation
- Building environmental control/lighting systems

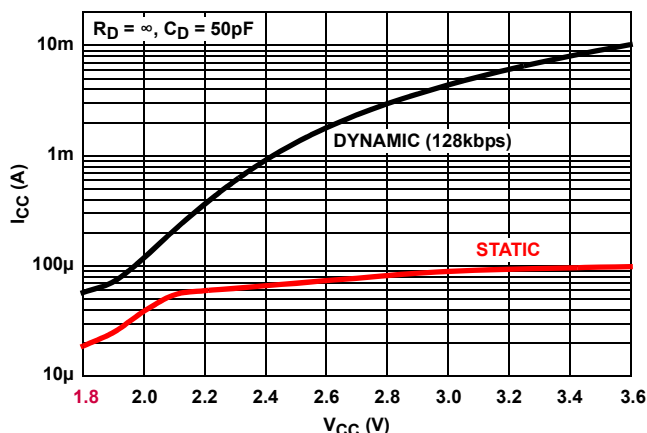

FIGURE 1. ISL32613E WITH V_{CC} = 1.8V REDUCES OPERATING I_{CC} BY A FACTOR OF 177 COMPARED WITH I_{CC} AT V_{CC} = 3.6V

Truth Table

TRANSMITTING			
INPUTS		OUTPUTS	
DE (Note 9)	DI	Z	Y
1	1	0	1
1	0	1	0
0	X	High-Z *	High-Z *

NOTE: *Shutdown Mode

Pin Configuration

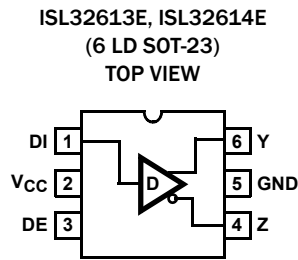

Pin Descriptions

PIN #	PIN NAME	FUNCTION
1	DI	Driver input. A low on DI forces output Y low and output Z high. Similarly, a high on DI forces output Y high and output Z low.
2	V _{CC}	System power supply input (1.8V to 3.6V).
3	DE	Driver output enable. The driver outputs, Y and Z, are enabled by bringing DE high, and are high impedance when DE is low. If the driver enable function is not needed, connect DE to V _{CC} through a 1kΩ to 2kΩ resistor.
4	Z	±16.5kV HBM, ±7kV IEC61000 (contact method) ESD Protected inverting differential transmitter output.
5	GND	Ground connection
6	Y	±16.5kV HBM, ±7kV IEC61000 (contact method) ESD Protected noninverting differential transmitter output.

TABLE 1. SUMMARY OF FEATURES AT V_{CC} = 1.8V

PART NUMBER	FUNCTION	DATA RATE (kbps)	SLEW-RATE LIMITED?	HOT PLUG?	TX ENABLE? (Note 9)	MAXIMUM QUIESCENT I _{CC} (μA)	LOW POWER SHUTDOWN?	PIN COUNT
ISL32613E	1 Tx	128	Yes	Yes	Yes	80	Yes	6 Ld SOT
ISL32614E	1 Tx	256	Yes	Yes	Yes	80	Yes	6 Ld SOT

Ordering Information

PART NUMBER (Notes 1, 2)	PART MARKING (Note 4)	TEMP RANGE (°C)	PACKAGE (RoHS Compliant)	PKG. DWG. #
ISL32613EFHZ-T	613F	-40 to +125	6 Ld SOT-23	P6.064
ISL32613EFHZ-T7A	613F	-40 to +125	6 Ld SOT-23	P6.064
ISL32614EFHZ-T	614F	-40 to +125	6 Ld SOT-23	P6.064
ISL32614EFHZ-T7A	614F	-40 to +125	6 Ld SOT-23	P6.064

NOTES:

- These Intersil Pb-free plastic packaged products employ special Pb-free material sets, molding compounds/die attach materials, and 100% matte tin plate plus anneal (e3 termination finish, which is RoHS compliant and compatible with both SnPb and Pb-free soldering operations). Intersil Pb-free products are MSL classified at Pb-free peak reflow temperatures that meet or exceed the Pb-free requirements of IPC/JEDEC J STD-020.
- Please refer to [TB347](#) for details on reel specifications.
- For Moisture Sensitivity Level (MSL), please see device information page for [ISL32613E](#), [ISL32614E](#). For more information on MSL please see techbrief [TB363](#).
- SOT-23 "PART MARKING" is branded on the bottom side.

Typical Operating Circuits

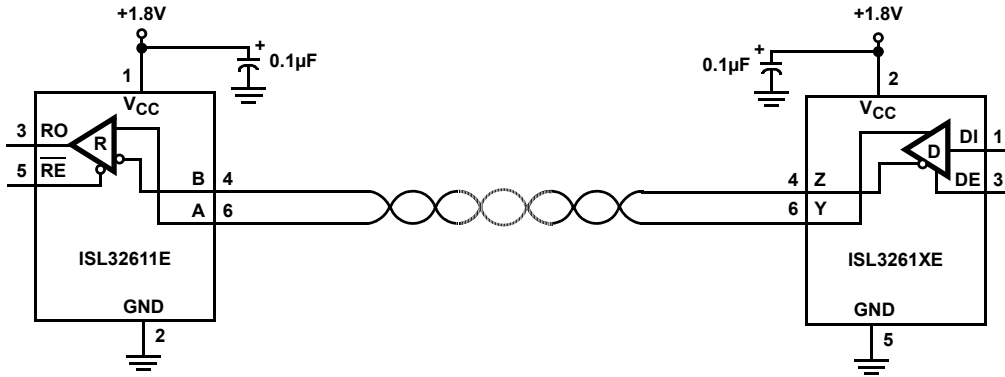

FIGURE 2. NETWORK WITH ENABLES

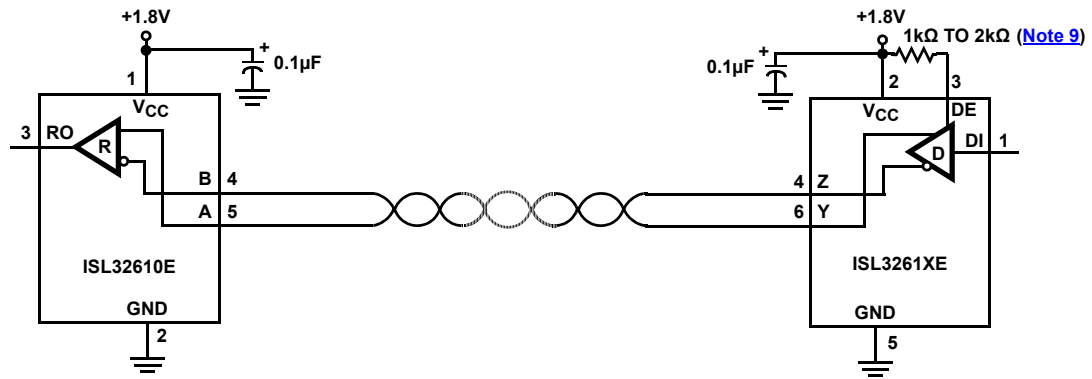

FIGURE 3. NETWORK WITHOUT ENABLES

Absolute Maximum Ratings

V _{CC} to GND	-0.3V to 7V
Input Voltages	
DI, DE	-0.3V to 7V
Output Voltages	
Y, Z (V _{CC} = 0V or ≥ 2.7V)	-8V to +13V
Y, Z (V _{CC} = 1.8V, Output Enabled)	-8V to +3V
Y, Z (V _{CC} = 1.8V, Output Disabled)	-8V to +8V
Short Circuit Duration	
Y, Z	Indefinite
ESD Rating	see "Electrical Specifications"
Latch-up (per JESD78, Level 2, Class A)	+125°C

Thermal Information

Thermal Resistance (Typical)	θ_{JA} (°C/W)	θ_{JC} (°C/W)
6 Ld SOT-23 Package (Notes 5, 6)	177	95
Maximum Junction Temperature (Plastic Package)	+150°C	
Maximum Storage Temperature Range	-65°C to +150°C	
Pb-free Reflow Profile	see TB493	

Recommended Operating Conditions

Supply Voltage Range	1.8V to 3.3V
Common Mode Range; V _{CC} = 1.8V	±2V
V _{CC} ≥ 2.7V	-7V to +12V
Temperature Range	
(F Suffix)	-40°C to +125°C
Differential Load (R _D); V _{CC} = 1.8V	≥10kΩ
V _{CC} ≥ 2.7V	≥60Ω

CAUTION: Do not operate at or near the maximum ratings listed for extended periods of time. Exposure to such conditions may adversely impact product reliability and result in failures not covered by warranty.

NOTES:

- θ_{JA} is measured with the component mounted on a high effective thermal conductivity test board in free air. See Tech Brief [TB379](#) for details.
- For θ_{JC} , the "case temp" location is taken at the package top center.

Electrical Specifications V_{CC} = 1.8V; typicals are at T_A = +25°C; unless otherwise specified. **Boldface limits apply across the operating temperature range.** ([Note 7](#))

PARAMETER	SYMBOL	TEST CONDITIONS	TEMP (°C)	MIN (Note 10)	TYP	MAX (Note 10)	UNIT	
DC CHARACTERISTICS								
Driver Differential V _{OUT}	V _{OD}	R _L = 100Ω (Figure 4)	V _{CC} = 1.8V	Full	0.8	0.92	-	V
			V _{CC} ≥ 3.15V	Full	2	-	-	V
		R _L = 54Ω (Figure 4), V _{CC} ≥ 3V		Full	1.5	-	-	V
		No Load		Full	1.1	1.45	V_{CC}	V
Change in Magnitude of Driver Differential V _{OUT} for Complementary Output States	ΔV _{OD}	R _L = 100Ω (Figure 4)	Full	-	0.01	0.2	V	
Driver Common Mode V _{OUT}	V _{OC}	R _L = 100Ω (Figure 4)	Full	-	1.1	1.4	V	
Change in Magnitude of Driver Common Mode V _{OUT} for Complementary Output States	ΔV _{OC}	R _L = 100Ω (Figure 4)	Full	-	0.01	0.2	V	
Logic Input High Voltage (DI, DE)	V _{IH}	V _{CC} = 1.8V	Full	1.26	-	-	V	
		2.7V ≤ V _{CC} ≤ 3.6V	Full	2.2	-	-	V	
Logic Input Low Voltage (DI, DE)	V _{IL}	V _{CC} = 1.8V	Full	-	-	0.4	V	
		2.7V ≤ V _{CC} ≤ 3.6V	Full	-	-	0.8	V	
Logic Input Current	I _{IN}	DI = DE = 0V or V _{CC} (Note 9)	Full	-2	-	2	μA	
Output Leakage Current (Y, Z, Note 9)	I _{OZ}	DE = 0V, V _{CC} = 0V or 1.8V, or 3.6V	V _O = 7V at V _{CC} = 1.8V	Full	-	0.1	30	μA
			V _O = 12V at V _{CC} = 3.6V	Full	-	0.1	40	μA
			V _O = -7V	Full	-40	-8	-	μA
Driver Short-circuit Current, V _O = High or Low (Note 8)	I _{OS}	V _{CC} = 1.8V, DE = V _{CC} , -2V ≤ V _O ≤ 2V	Full	-	-	±250	mA	
		V _{CC} ≥ 2.7V, DE = V _{CC} , -7V ≤ V _O ≤ 12V	Full	-	±150	-	mA	

Electrical Specifications $V_{CC} = 1.8V$; typicals are at $T_A = +25^\circ C$; unless otherwise specified. **Boldface limits apply across the operating temperature range. (Note 7) (Continued)**

PARAMETER	SYMBOL	TEST CONDITIONS	TEMP (°C)	MIN (Note 10)	TYP	MAX (Note 10)	UNIT	
SUPPLY CURRENT								
No-load Supply Current	I_{CC}	$DE = V_{CC} = 1.8V, DI = 0V \text{ or } V_{CC}$	Full	-	20	80	μA	
		$DE = V_{CC}, 2.7V \leq V_{CC} \leq 3.6V, DI = 0V \text{ or } V_{CC}$	Full	-	100	150	μA	
Shutdown Supply Current	I_{SHDN}	$1.8V \leq V_{CC} \leq 3.6V, DE = 0V, DI = 0V \text{ or } V_{CC}$	Full	-	0.01	2	μA	
ESD PERFORMANCE								
RS-485 Pins (Y, Z)		Human Body Model, from bus pins to GND	25	-	± 16.5	-	kV	
		IEC61000 Contact, from bus pins to GND	25	-	± 7	-	kV	
All Pins		HBM, per MIL-STD-883 Method 3015	25	-	± 8	-	kV	
		Machine Model	25	-	± 400	-	V	
DRIVER SWITCHING CHARACTERISTICS (ISL32613E, 128kbps Version)								
Maximum Data Rate	f_{MAX}		$V_{CC} = 1.8V$	Full	128	-	-	kbps
			$3V \leq V_{CC} \leq 3.6V$	Full	256	-	-	kbps
Driver Differential Output Delay	t_{DD}	$C_D = 50pF$ (Figure 5)	$V_{CC} = 1.8V$	Full	-	1700	2600	ns
			$3V \leq V_{CC} \leq 3.6V$	Full	-	1100	1500	ns
Driver Differential Output Skew	t_{DSK}	$C_D = 50pF$ (Figure 5)	$V_{CC} = 1.8V$	Full	-	30	200	ns
			$3V \leq V_{CC} \leq 3.6V$	Full	-	2	30	ns
Driver Differential Rise or Fall Time	t_R, t_F	$C_D = 50pF$ (Figure 5)	$V_{CC} = 1.8V$	Full	-	1600	2600	ns
			$3V \leq V_{CC} \leq 3.6V$	Full	400	960	1500	ns
Driver Enable to Output High	t_{ZH}	$R_L = 500\Omega, C_L = 50pF, SW = GND$ (Figure 6)	Full	-	460	800	ns	
Driver Enable to Output Low	t_{ZL}	$R_L = 500\Omega, C_L = 50pF, SW = V_{CC}$ (Figure 6)	Full	-	460	800	ns	
Driver Disable from Output High	t_{HZ}	$R_L = 500\Omega, C_L = 50pF, SW = GND$ (Figure 6)	Full	-	60	250	ns	
Driver Disable from Output Low	t_{LZ}	$R_L = 500\Omega, C_L = 50pF, SW = V_{CC}$ (Figure 6)	Full	-	60	250	ns	
DRIVER SWITCHING CHARACTERISTICS (ISL32614E, 256kbps Version)								
Maximum Data Rate	f_{MAX}	$R_D = \infty, C_D = 50pF$	$V_{CC} = 1.8V$	Full	256	-	-	kbps
			$3V \leq V_{CC} \leq 3.6V$	Full	500	-	-	kbps
Driver Differential Output Delay	t_{DD}	$R_D = \infty, C_D = 50pF$ (Figure 5)	$V_{CC} = 1.8V$	Full	-	700	2000	ns
			$3V \leq V_{CC} \leq 3.6V$	Full	-	350	500	ns
Driver Differential Output Skew	t_{DSK}	$R_D = \infty, C_D = 50pF$ (Figure 5)	$V_{CC} = 1.8V$	Full	-	30	200	ns
			$3V \leq V_{CC} \leq 3.6V$	Full	-	2	30	ns
Driver Differential Rise or Fall Time	t_R, t_F	$R_D = \infty, C_D = 50pF$ (Figure 5)	$V_{CC} = 1.8V$	Full	-	1700	2600	ns
			$3V \leq V_{CC} \leq 3.6V$	Full	200	350	800	ns
Driver Enable to Output High	t_{ZH}	$R_L = 500\Omega, C_L = 50pF, SW = GND$ (Figure 6)	Full	-	460	800	ns	
Driver Enable to Output Low	t_{ZL}	$R_L = 500\Omega, C_L = 50pF, SW = V_{CC}$ (Figure 6)	Full	-	460	800	ns	
Driver Disable from Output High	t_{HZ}	$R_L = 500\Omega, C_L = 50pF, SW = GND$ (Figure 6)	Full	-	60	250	ns	
Driver Disable from Output Low	t_{LZ}	$R_L = 500\Omega, C_L = 50pF, SW = V_{CC}$ (Figure 6)	Full	-	60	250	ns	

NOTES:

- All currents into device pins are positive; all currents out of device pins are negative. All voltages are referenced to device ground unless otherwise specified.
- Applies to peak current. See "Typical Performance Curves" on page 8 for more information.
- If the Driver Enable function is not needed, connect DE to V_{CC} through a 1k Ω to 2k Ω resistor.
- Compliance to data sheet limits is assured by one or more methods: production test, characterization and/or design.

Test Circuits and Waveforms

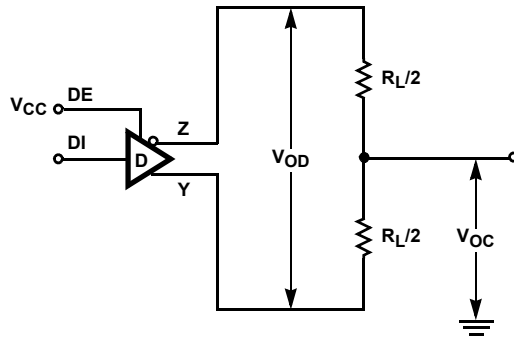

FIGURE 4. DC DRIVER TEST CIRCUITS

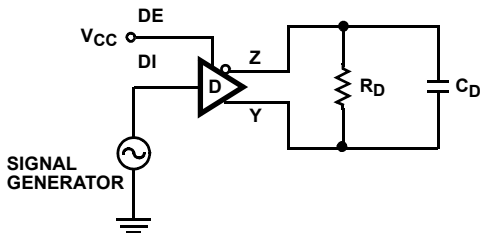
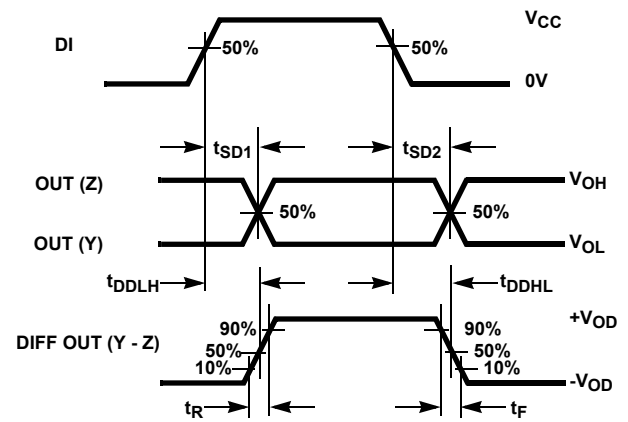

FIGURE 5A. TEST CIRCUIT



$$t_{SSK} = |t_{SD1(Y)} - t_{SD2(Y)}| \text{ OR } |t_{SD1(Z)} - t_{SD2(Z)}| \quad t_{DSK} = |t_{DDLH} - t_{DDHL}|$$

FIGURE 5B. MEASUREMENT POINTS

FIGURE 5. DRIVER PROPAGATION DELAY AND DIFFERENTIAL TRANSITION TIMES

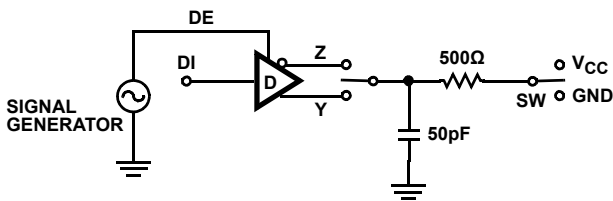

FIGURE 6A. TEST CIRCUIT

PARAMETER	OUTPUT	DI	SW
t_{HZ}	Y/Z	1/0	GND
t_{LZ}	Y/Z	0/1	V_{CC}
t_{zH}	Y/Z	1/0	GND
t_{zL}	Y/Z	0/1	V_{CC}

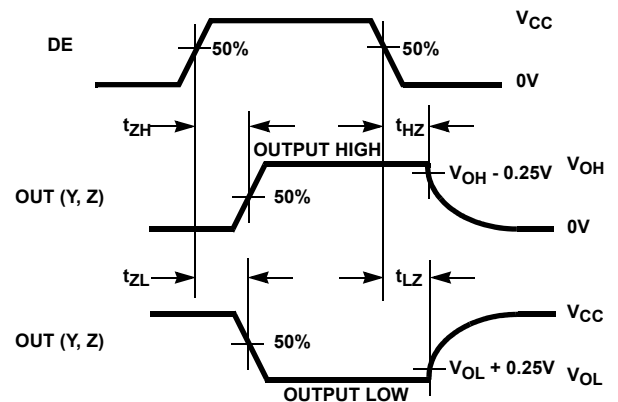

FIGURE 6B. MEASUREMENT POINTS

FIGURE 6. DRIVER ENABLE AND DISABLE TIMES

Application Information

Driver Features

These transmitters are differential output devices that operate with V_{CC} as low as 1.8V, and up to 3.6V. Devices are RS-485 compliant with $V_{CC} \geq 3V$, but significant power savings are obtained by operating at $V_{CC} = 1.8V$.

The transmitter outputs are tri-statable via the active high DE input. If the Tx enable function is not needed, tie DE to V_{CC} through a 1k Ω to 2k Ω resistor. Outputs are slew rate limited to minimize EMI, and to reduce reflections in unterminated or improperly terminated networks.

1.8V Operation

The ISL32613E and ISL32614E operate with V_{CC} as low as 1.8V. When coupled with the ISL32610E or ISL32611E 1.8V receivers, they provide a differential communication link optimized for very low power, and for slow data rates. [Figures 9](#) and [10](#) illustrate the static and dynamic power savings from using these transmitters at low supply voltages. With $V_{CC} = 1.8V$ rather than 3.3V, using the ISL32613E at 128kbps reduces the operating supply current from 9.9mA to 56 μ A (a factor of 177).

5.5V Tolerant Logic Pins

Logic input pins (DI, DE) contain no ESD or parasitic diodes to V_{CC} , so they withstand input voltages exceeding 5.5V, regardless of the V_{CC} voltage.

Hot Plug Function

When a piece of equipment powers up, there is a period of time during which the processor or ASIC driving the RS-485 control line (DE) is unable to ensure that the RS-485 Tx outputs are kept disabled. If the equipment is connected to the bus, a driver activating prematurely during power-up may crash the bus. To avoid this scenario, these transmitters incorporate a "Hot Plug" function. During power-up, circuitry monitoring V_{CC} ensures that the Tx outputs remain disabled for a period of time, regardless of the state of DE. This gives the processor/ASIC a chance to stabilize and drive the control lines to the proper states.

ESD Protection

All pins on these devices include class 3 (8kV) Human Body Model (HBM) ESD protection structures, but the driver outputs incorporate advanced structures that allow them to survive ESD events in excess of $\pm 16.5kV$ HBM and $\pm 7kV$ to the IEC61000 contact test method. The RS-485 pins are particularly vulnerable to ESD damage because they typically connect to an exposed port on the exterior of the finished product. Simply touching the port pins, or connecting a cable, can cause an ESD event that might destroy unprotected ICs. These new ESD structures protect the device whether it is powered up or not, and without degrading the common mode range. This built-in ESD protection eliminates the need for board-level protection structures (e.g., transient suppression diodes) and the associated, undesirable capacitive load they present.

Driver Overload Protection

The driver output stages incorporate short-circuit, current-limiting circuitry, which ensures that the output current never exceeds the RS-485 specification over a $\pm 2V$ (-7V to +12V for $V_{CC} \geq 2.7V$) common mode voltage range.

In the event of a major short-circuit condition, the device also includes a thermal shutdown feature that disables the drivers whenever the die temperature becomes excessive. This eliminates power dissipation, allowing the die to cool. The drivers automatically reenables after the die temperature drops by about +20°C. If the condition persists, the thermal shutdown/reenables cycle repeats until the fault is cleared.

Low Power Shutdown Mode

This BiCMOS transmitter uses a fraction of the power required by its bipolar counterparts, but it also includes a shutdown feature that reduces the already low quiescent I_{CC} to a 10nA trickle. This device enters shutdown whenever the driver disables (DE = GND).

Typical Performance Curves $V_{CC} = 1.8V, T_A = +25^\circ C$; unless otherwise specified.

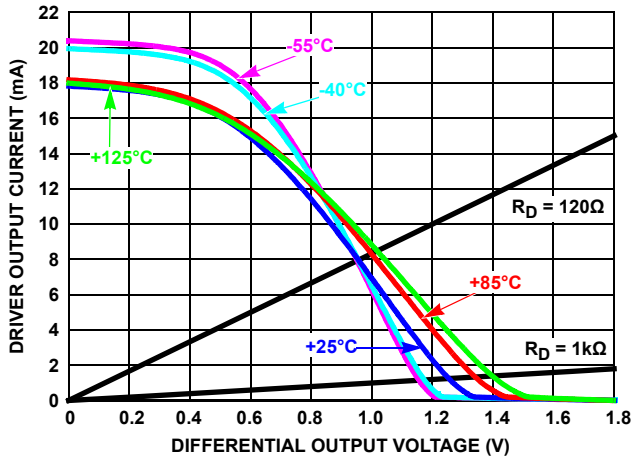

FIGURE 7. DRIVER OUTPUT CURRENT vs DIFFERENTIAL OUTPUT VOLTAGE

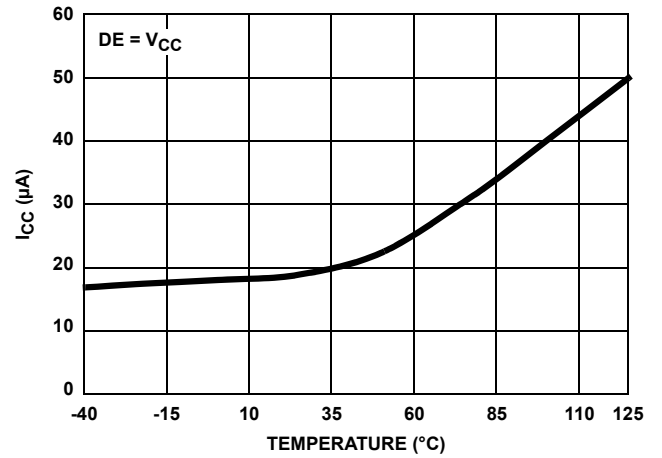

FIGURE 8. STATIC SUPPLY CURRENT vs TEMPERATURE

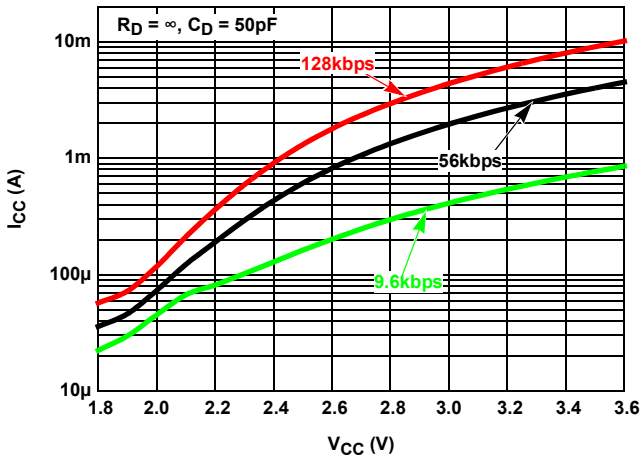

FIGURE 9. ISL32613E DYNAMIC SUPPLY CURRENT vs SUPPLY VOLTAGE AT DIFFERENT DATA RATES

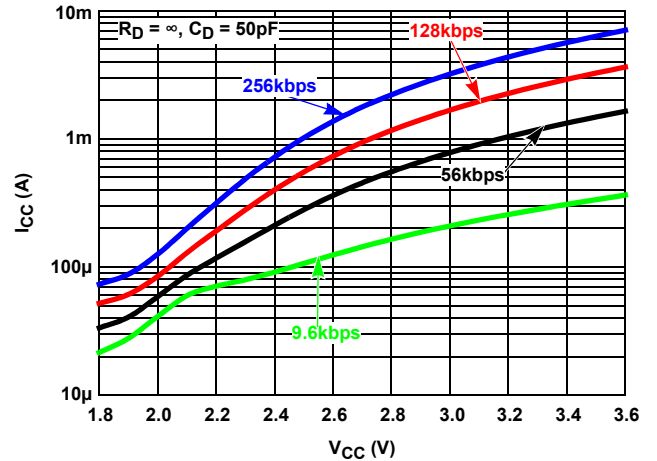

FIGURE 10. ISL32614E DYNAMIC SUPPLY CURRENT vs SUPPLY VOLTAGE AT DIFFERENT DATA RATES

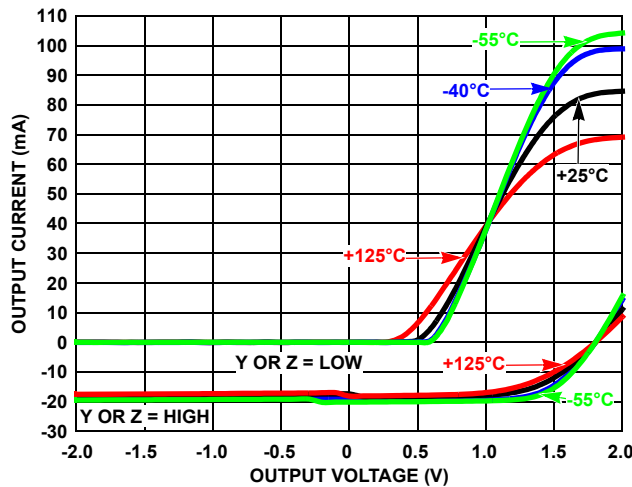

FIGURE 11. DRIVER OUTPUT CURRENT vs SHORT-CIRCUIT VOLTAGE

Typical Performance Curves $V_{CC} = 1.8V, T_A = +25^\circ C$; unless otherwise specified. (Continued)

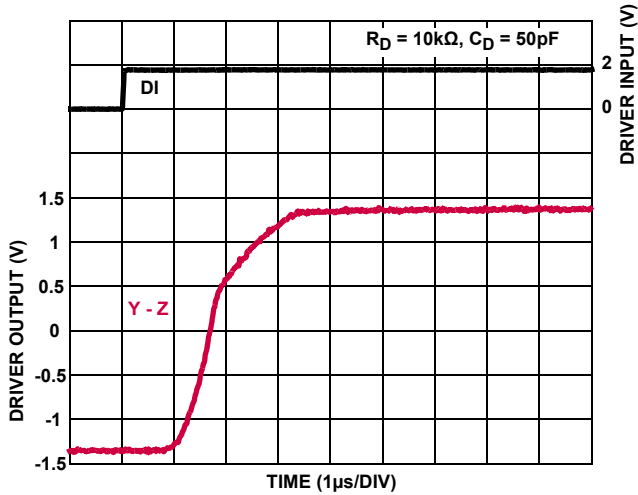

FIGURE 12. ISL32613E DRIVER WAVEFORMS, LOW-TO-HIGH

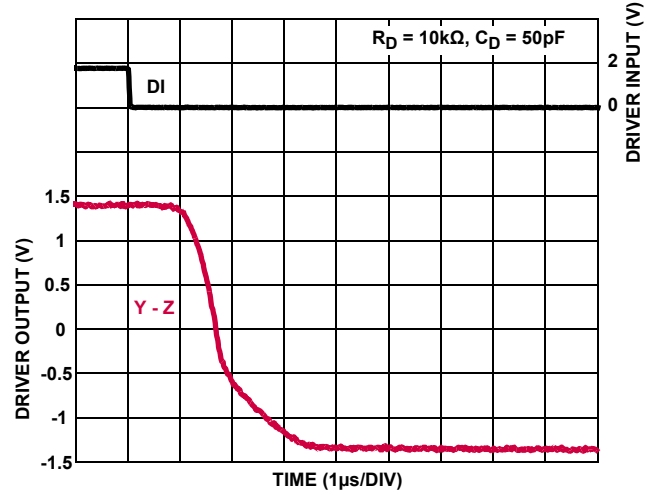

FIGURE 13. ISL32614E DRIVER WAVEFORMS, HIGH-TO-LOW

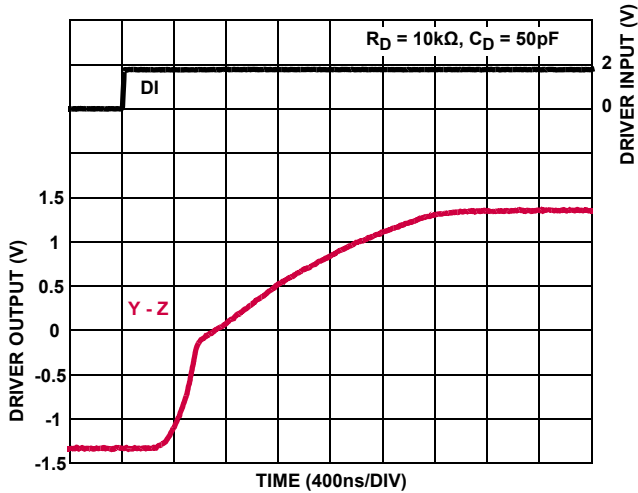

FIGURE 14. ISL32614E DRIVER WAVEFORMS, LOW-TO-HIGH

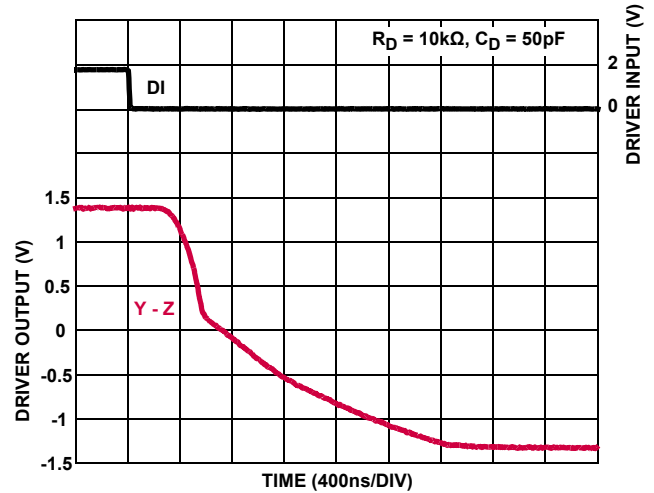

FIGURE 15. ISL32614E DRIVER WAVEFORMS, HIGH-TO-LOW

Die Characteristics

SUBSTRATE POTENTIAL (POWERED UP):

GND

PROCESS:

Si Gate BiCMOS

Revision History

The revision history provided is for informational purposes only and is believed to be accurate, but not warranted. Please go to web to make sure you have the latest revision.

DATE	REVISION	CHANGE
July 27, 2015	FN7906.2	Ordering Information Table on page 2: Removed part numbers ISL32614EMHZ-T and ISL32614EMHZ-T7A. Recommended Operating Conditions table on page 4: Removed the line referencing "M Suffix". Replaced "Product" section with "About Intersil" on page 10.
May 2, 2012	FN7906.1	Page 1, "Features" - changed "Specified for +125°C Operation" to "Specified for +125°C or Full Mil Temperature Operation". Also changed Figure 1 title. Page 2, added new part "ISL32614EMHZ-T" to the "Ordering Information". Page 4, changed "Y, Z (V _{CC} = 1.8V)" to "Y, Z (V _{CC} = 1.8V, Output Enabled)" and added "Y, Z (V _{CC} = 1.8V, Output Disabled)... -8V to +8V" under the "Absolute Maximum Rating". Also added "(F Suffix)" and "(M Suffix)...-55°C to +125°C" under the "Recommended Operating Conditions". Page 8, replaced Figure 7 and added -55°C curve to Figure 11 under the "Typical Performance Curves".
August 30, 2011	FN7906.0	Initial Release

About Intersil

Intersil Corporation is a leading provider of innovative power management and precision analog solutions. The company's products address some of the largest markets within the industrial and infrastructure, mobile computing and high-end consumer markets.

For the most updated datasheet, application notes, related documentation and related parts, please see the respective product information page found at www.intersil.com.

You may report errors or suggestions for improving this datasheet by visiting www.intersil.com/ask.

Reliability reports are also available from our website at www.intersil.com/support

© Copyright Intersil Americas LLC 2011-2015. All Rights Reserved.
All trademarks and registered trademarks are the property of their respective owners.

For additional products, see www.intersil.com/en/products.html

Intersil products are manufactured, assembled and tested utilizing ISO9001 quality systems as noted in the quality certifications found at www.intersil.com/en/support/qualandreliability.html

Intersil products are sold by description only. Intersil may modify the circuit design and/or specifications of products at any time without notice, provided that such modification does not, in Intersil's sole judgment, affect the form, fit or function of the product. Accordingly, the reader is cautioned to verify that datasheets are current before placing orders. Information furnished by Intersil is believed to be accurate and reliable. However, no responsibility is assumed by Intersil or its subsidiaries for its use; nor for any infringements of patents or other rights of third parties which may result from its use. No license is granted by implication or otherwise under any patent or patent rights of Intersil or its subsidiaries.

For information regarding Intersil Corporation and its products, see www.intersil.com

Package Outline Drawing

P6.064

6 LEAD SMALL OUTLINE TRANSISTOR PLASTIC PACKAGE

Rev 4, 2/10

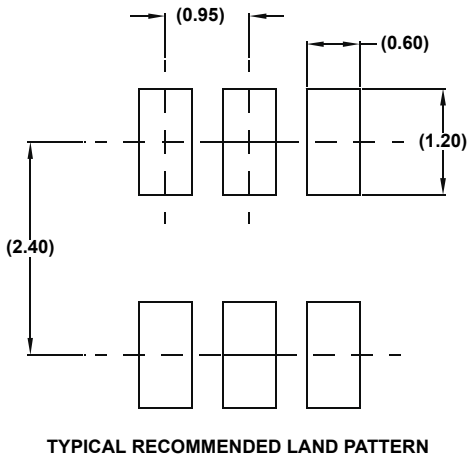
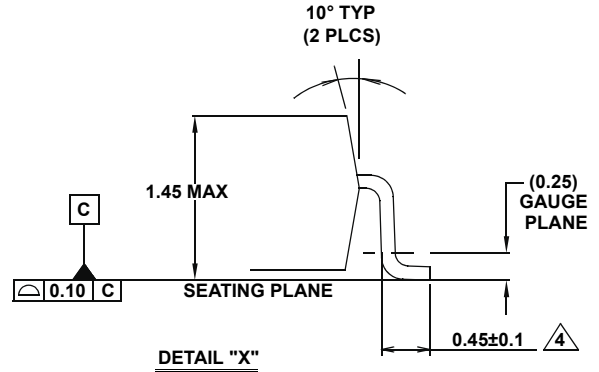
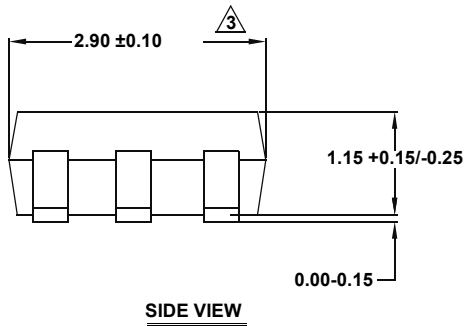
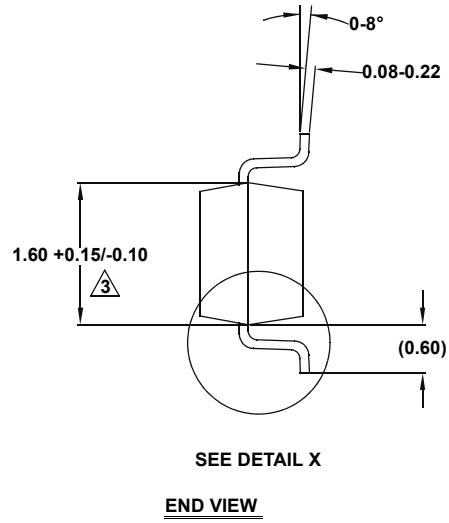
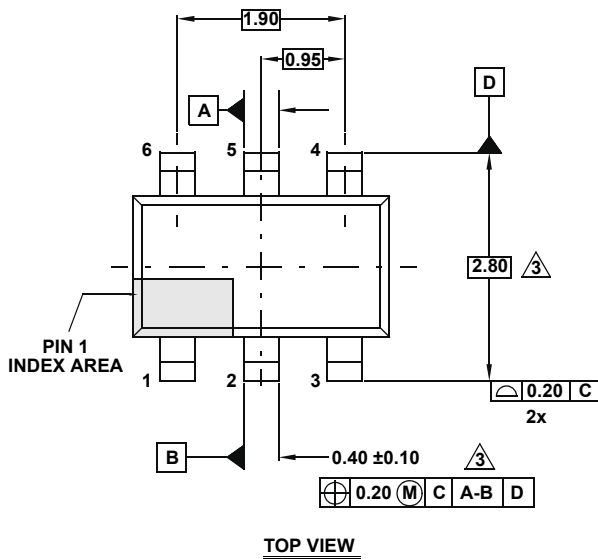

NOTES:

1. Dimensions are in millimeters.
Dimensions in () for Reference Only.
2. Dimensioning and tolerancing conform to ASME Y14.5M-1994.
3. Dimension is exclusive of mold flash, protrusions or gate burrs.
4. Foot length is measured at reference to gauge plane.
5. Package conforms to JEDEC MO-178AB.

Mouser Electronics

Authorized Distributor

Click to View Pricing, Inventory, Delivery & Lifecycle Information:

[Intersil:](#)

[ISL32614EMHZ-T](#) [ISL32614EMHZ-T7A](#)