

## SN65HVDA1050A-Q1 EMC-Optimized High-Speed CAN Bus Transceiver

### 1 Features

- Qualified for Automotive Applications
- Meets or Exceeds the Requirements of ISO 11898-2
- GIFT/ICT Compliant
- ESD Protection up to  $\pm 12$  kV (Human-Body Model) on Bus Pins
- High Electromagnetic Compliance (EMC)
- SPLIT ( $V_{REF}$ ) Voltage Source for Common-Mode Stabilization of Bus Through Split Termination
- Digital Inputs Compatible With 3.3-V and 5-V Microprocessors
- Protection Features
  - Bus-Fault Protection of  $-27$  V to 40 V
  - TXD Dominant Time-Out
  - Thermal Shutdown Protection
  - Power-Up and Power-Down Glitch-Free Bus Inputs and Outputs

### 2 Applications

- GMW3122 Dual-Wire CAN Physical Layer
- SAE J2284 High-Speed CAN for Automotive Applications
- SAE J1939 Standard Data Bus Interface
- ISO 11783 Standard Data Bus Interface
- NMEA 2000 Standard Data Bus Interface

### 3 Description

The SN65HVDA1050A-Q1 meets or exceeds the specifications of the ISO 11898 standard for use in applications employing a controller area network (CAN). The device is qualified for use in automotive applications. As a CAN bus transceiver, this device provides differential transmit capability to the bus and differential receive capability to a CAN controller at signaling rates up to 1 megabit per second (Mbps). The signaling rate of a line is the number of voltage transitions that are made per second expressed in bits per second (bps).

The SN65HVDA1050A-Q1 device is designed for operation in especially harsh environments and includes many device protection features such as undervoltage lockout, overtemperature thermal shutdown, wide common-mode range, and loss of ground protection. The bus pins are also protected against external cross-wiring, shorts to sources from  $-27$  V to 40 V, and voltage transients according to ISO 7637.

#### Device Information<sup>(1)</sup>

PART NUMBER	PACKAGE	BODY SIZE (NOM)
SN65HVDA1050A-Q1	SOIC (8)	4.90 mm x 3.91 mm

(1) For all available packages, see the orderable addendum at the end of the data sheet.

#### Block Diagram

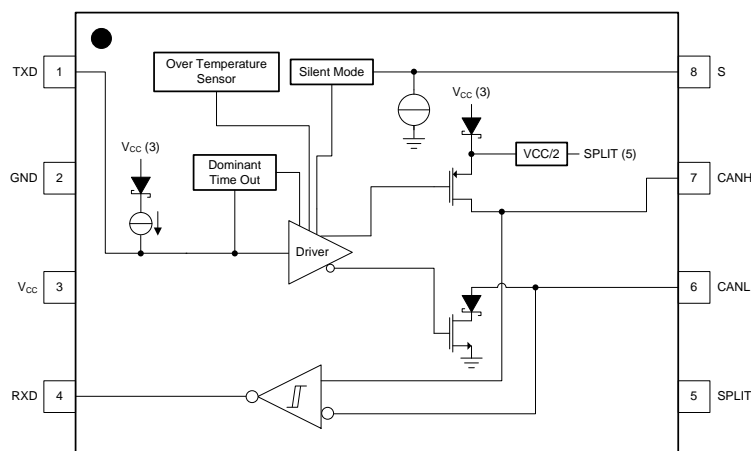

## Table of Contents

<b>1 Features</b> ..... 1 <b>2 Applications</b> ..... 1 <b>3 Description</b> ..... 1 <b>4 Revision History</b> ..... 2 <b>5 Pin Configuration and Functions</b> ..... 3 <b>6 Specifications</b> ..... 4 6.1 Absolute Maximum Ratings ..... 4 6.2 ESD Ratings ..... 4 6.3 Recommended Operating Conditions ..... 4 6.4 Thermal Information ..... 5 6.5 Electrical Characteristics ..... 5 6.6 Power Dissipation Characteristics ..... 7 6.7 Switching Characteristics ..... 7 6.8 Typical Characteristics ..... 8 <b>7 Parameter Measurement Information</b> ..... 9 <b>8 Detailed Description</b> ..... 14 8.1 Overview ..... 14	8.2 Functional Block Diagram ..... 14 8.3 Feature Description ..... 14 8.4 Device Functional Modes ..... 16 <b>9 Application and Implementation</b> ..... 17 9.1 Application Information ..... 17 9.2 Typical Application ..... 18 <b>10 Power Supply Recommendations</b> ..... 21 <b>11 Layout</b> ..... 21 11.1 Layout Guidelines ..... 21 11.2 Layout Example ..... 22 <b>12 Device and Documentation Support</b> ..... 23 12.1 Community Resources ..... 23 12.2 Trademarks ..... 23 12.3 Electrostatic Discharge Caution ..... 23 12.4 Glossary ..... 23 <b>13 Mechanical, Packaging, and Orderable Information</b> ..... 23
--	--

## 4 Revision History

NOTE: Page numbers for previous revisions may differ from page numbers in the current version.

Changes from Revision A (December 2010) to Revision B	Page
<ul style="list-style-type: none"> <li>• Added <i>Pin Configuration and Functions</i> section, <i>ESD Ratings</i> table, <i>Switching Characteristics</i> table, <i>Power Dissipation Characteristics</i> table, <i>Feature Description</i> section, <i>Device Functional Modes</i>, <i>Application and Implementation</i> section, <i>Power Supply Recommendations</i> section, <i>Layout</i> section, <i>Device and Documentation Support</i> section, and <i>Mechanical, Packaging, and Orderable Information</i> section .....</li> </ul>	1

## 5 Pin Configuration and Functions

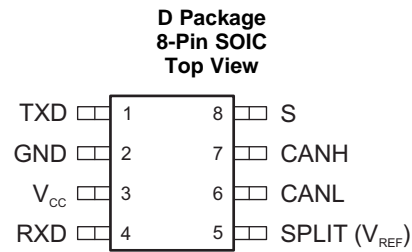

### Pin Functions

PIN		TYPE	DESCRIPTION
NO.	NAME		
1	TXD	I	CAN transmit data input (low for dominant bus state, high for recessive bus state)
2	GND	GND	Ground connection
3	V <sub>CC</sub>	Supply	Transceiver 5-V supply voltage input
4	RXD	O	CAN receiver data output (low in dominant bus state, high in recessive bus state)
5	SPLIT (V <sub>REF</sub> )	O	Common-mode stabilization output for split termination
6	CANL	I/O	LOW-level CAN bus line
7	CANH	I/O	HIGH-level CAN bus line
8	S	I	Silent mode select pin (active-high)

## 6 Specifications

### 6.1 Absolute Maximum Ratings

 over operating free-air temperature range (unless otherwise noted)<sup>(1)</sup>

		MIN	MAX	UNIT
V <sub>CC</sub>	Supply voltage <sup>(2)</sup>	-0.3	6	V
	Voltage at any bus terminal [CANH, CANL, SPLIT (V <sub>REF</sub> )]	-27	40	V
I <sub>O</sub>	Receiver output current		20	mA
V <sub>I</sub>	Voltage input, ISO 7637 transient pulse <sup>(3)</sup> (CANH, CANL)	-150	100	V
V <sub>I</sub>	Voltage input (TXD, S)	-0.3	6	V
T <sub>J</sub>	Junction temperature	-40	150	°C
T <sub>stg</sub>	Storage temperature	-65	150	°C

- (1) Stresses beyond those listed under *Absolute Maximum Ratings* may cause permanent damage to the device. These are stress ratings only, which do not imply functional operation of the device at these or any other conditions beyond those indicated under *Recommended Operating Conditions*. Exposure to absolute-maximum-rated conditions for extended periods may affect device reliability.
- (2) All voltage values, except differential I/O bus voltages, are with respect to the network ground terminal.
- (3) Tested in accordance with ISO 7637 test pulses 1, 2, 3a, 3b per IBEE system level test (Pulse 1 = -100 V, Pulse 2 = 100 V, Pulse 3a = -150 V, Pulse 3b = 100 V). If DC may be coupled with AC transients, externally protect the bus pins within the absolute maximum voltage range at any bus terminal. This device has been tested with DC bus shorts to 40 V with leading common-mode chokes. If common-mode chokes are used in the system and the bus lines may be shorted to DC, ensure that the choke type and value in combination with the node termination and shorting voltage either do not create inductive flyback outside of voltage maximum specification or use an external transient-suppression circuit to protect the transceiver from the inductive transients.

### 6.2 ESD Ratings

			VALUE	UNIT	
V <sub>(ESD)</sub>	Electrostatic discharge	Human body model (HBM), per AEC Q100-002 <sup>(1)</sup>	Bus pins <sup>(2)</sup> : Pin 7 (CANH) and Pin 6 (CANL)	±12000	V
			Pin 5 [SPLIT (V <sub>REF</sub> )] <sup>(3)</sup>	±10000	
			All pins	±4000	
		Charged-device model (CDM), per AEC Q100-011	±1500		
		Machine model <sup>(4)</sup>	±200		
		IEC 61400-4-2 according to IBEE CAN EMC test specification	Bus pins to GND: Pin 7 (CANH) and Pin 6 (CANL)	±7000	

- (1) AEC Q100-002 indicates that HBM stressing shall be in accordance with the ANSI/ESDA/JEDEC JS-001 specification.
- (2) Test method based upon JEDEC Standard 22 Test Method A114F and AEC-Q100-002, CANH and CANL bus pins stressed with respect to each other and GND.
- (3) Test method based upon JEDEC Standard 22 Test Method A114F and AEC-Q100-002, SPLIT pin stressed with respect to GND.
- (4) Tested in accordance JEDEC Standard 22, Test Method A115A.

### 6.3 Recommended Operating Conditions

over operating free-air temperature range (unless otherwise noted)

			MIN	MAX	UNIT
V <sub>CC</sub>	Supply voltage		4.75	5.25	V
V <sub>I</sub> or V <sub>IC</sub>	Voltage at any bus terminal (separately or common mode)		-12	12	V
V <sub>IH</sub>	High-level input voltage	TXD, S	2	5.25	V
V <sub>IL</sub>	Low-level input voltage	TXD, S	0	0.8	V
V <sub>ID</sub>	Differential input voltage		-6	6	V
I <sub>OH</sub>	High-level output current	Driver	-70		mA
		Receiver (RXD)	-2		
I <sub>OL</sub>	Low-level output current	Driver		70	mA
		Receiver (RXD)		2	
T <sub>A</sub>	Operating free-air temperature	See <a href="#">Power Dissipation Characteristics</a>	-40	125	°C

## 6.4 Thermal Information

THERMAL METRIC <sup>(1)</sup>		SN65HVDA1050A-Q1		UNIT	
		D (SOIC)			
		8 PINS			
R <sub>θJA</sub>	Junction-to-ambient thermal resistance	Low-K thermal resistance <sup>(2)</sup>		211	°C/W
		High-K thermal resistance <sup>(2)</sup>		109	°C/W
R <sub>θJC(top)</sub>	Junction-to-case (top) thermal resistance			49.2	°C/W
R <sub>θJB</sub>	Junction-to-board thermal resistance			50.3	°C/W
ψ <sub>JT</sub>	Junction-to-top characterization parameter			8	°C/W
ψ <sub>JB</sub>	Junction-to-board characterization parameter			49.6	°C/W
R <sub>θJC(bot)</sub>	Junction-to-case (bottom) thermal resistance			49.2	°C/W

(1) For more information about traditional and new thermal metrics, see the *Semiconductor and IC Package Thermal Metrics* application report, [SPRA953](#).

(2) Tested in accordance with the low-K (EIA/JESD51-3) or high-K (EIA/JESD51-7) thermal metric definitions for leaded surface-mount packages.

## 6.5 Electrical Characteristics

over recommended operating conditions, T<sub>A</sub> = –40 to 125°C (unless otherwise noted)

PARAMETER		TEST CONDITIONS		MIN	TYP <sup>(1)</sup>	MAX	UNIT
<b>SUPPLY</b>							
I <sub>CC</sub>	5-V supply current	Silent mode	S at V <sub>CC</sub> , V <sub>I</sub> = V <sub>CC</sub>		6	10	mA
		Dominant	V <sub>I</sub> = 0 V, 60-Ω load, S = 0 V		50	70	
		Recessive	V <sub>I</sub> = V <sub>CC</sub> , No load, S = 0 V		6	10	
UV <sub>CC</sub>	Undervoltage reset threshold			2.8		4	V
<b>DRIVER</b>							
V <sub>O(D)</sub>	Bus output voltage (dominant)	CANH	V <sub>I</sub> = 0 V, S = 0 V, R <sub>L</sub> = 60 Ω (see <a href="#">Figure 3</a> and <a href="#">Figure 14</a> )	2.9	3.4	4.5	V
		CANL		0.85	1.2	1.5	
V <sub>O(R)</sub>	Bus output voltage (recessive)		V <sub>I</sub> = 3 V, S = 0 V, R <sub>L</sub> = 60 Ω (see <a href="#">Figure 3</a> and <a href="#">Figure 14</a> )	2	2.3	3	V
V <sub>OD(D)</sub>	Differential output voltage (dominant)		V <sub>I</sub> = 0 V, R <sub>L</sub> = 60 Ω, S = 0 V (see <a href="#">Figure 3</a> , <a href="#">Figure 14</a> , and <a href="#">Figure 4</a> )	1.5		3	V
			V <sub>I</sub> = 0 V, R <sub>L</sub> = 45 Ω, S = 0 V (see <a href="#">Figure 3</a> , <a href="#">Figure 14</a> , and <a href="#">Figure 4</a> )	1.4		3	V
V <sub>OD(R)</sub>	Differential output voltage (recessive)		V <sub>I</sub> = 3 V, S = 0 V (see <a href="#">Figure 3</a> and <a href="#">Figure 14</a> )	–0.012		0.012	V
			V <sub>I</sub> = 3 V, S = 0 V, No Load	–0.5		0.05	
V <sub>OC(ss)</sub>	Steady-state common-mode output voltage		S = 0 V (see <a href="#">Figure 9</a> )	2	2.3	3	V
ΔV <sub>OC(ss)</sub>	Change in steady-state common-mode output voltage		S = 0 V (see <a href="#">Figure 9</a> )		30		mV
V <sub>IH</sub>	High-level input voltage, TXD input			2			V
V <sub>IL</sub>	Low-level input voltage, TXD input					0.8	V
I <sub>IH</sub>	High-level input current, TXD input		V <sub>I</sub> at V <sub>CC</sub>	–2		2	μA
I <sub>IL</sub>	Low-level input current, TXD input		V <sub>I</sub> at 0 V	–50		–10	μA
I <sub>O(off)</sub>	Power-off TXD output current		V <sub>CC</sub> at 0 V, TXD at 5 V			1	μA

(1) All typical values are at 25°C with a 5-V supply.

**Electrical Characteristics (continued)**

 over recommended operating conditions,  $T_A = -40$  to  $125^\circ\text{C}$  (unless otherwise noted)

PARAMETER	TEST CONDITIONS	MIN	TYP <sup>(1)</sup>	MAX	UNIT	
<b>DRIVER (continued)</b>						
$I_{OS(ss)}$	Short-circuit steady-state output current, dominant	$V_{CANH} = -12\text{ V}$ , CANL open (see <a href="#">Figure 12</a> )	-105	-72		mA
		$V_{CANH} = 12\text{ V}$ , CANL open (see <a href="#">Figure 12</a> )		0.36	1	
		$V_{CANL} = -12\text{ V}$ , CANH open (see <a href="#">Figure 12</a> )	-1	-0.5		
		$V_{CANL} = 12\text{ V}$ , CANH open (see <a href="#">Figure 12</a> )		71	105	
		$V_{CANH} = 0\text{ V}$ , CANL open, TXD = low, (see <a href="#">Figure 12</a> )	-100	-70		
		$V_{CANL} = 32\text{ V}$ , CANH open, TXD = low, (see <a href="#">Figure 12</a> )		75	140	
$I_{OS(ss)}$	Short-circuit steady-state output current, recessive	$-20\text{ V} \leq V_{CANH} \leq 32\text{ V}$ , CANL open, TXD = high (see <a href="#">Figure 12</a> )	-15		15	mA
		$-20\text{ V} \leq V_{CANL} \leq 32\text{ V}$ , CANH open, TXD = high (see <a href="#">Figure 12</a> )	-15		15	
$C_O$	Output capacitance	See receiver input capacitance				
<b>RECEIVER</b>						
$V_{IT+}$	Positive-going input threshold voltage	$S = 0\text{ V}$ (see <a href="#">Table 1</a> )		800	900	mV
$V_{IT-}$	Negative-going input threshold voltage	$S = 0\text{ V}$ (see <a href="#">Table 1</a> )	500	650		mV
$V_{hys}$	Hysteresis voltage ( $V_{IT+} - V_{IT-}$ )		100	125		mV
$V_{OH}$	High-level output voltage	$I_O = -2\text{ mA}$ (see <a href="#">Figure 7</a> )	4	4.6		V
$V_{OL}$	Low-level output voltage	$I_O = 2\text{ mA}$ (see <a href="#">Figure 7</a> )		0.2	0.4	V
$I_{I(off)}$	Power-off bus input current (unpowered bus leakage current)	CANH or CANL = 5 V, Other pin at 0 V, $V_{CC}$ at 0 V, TXD at 0 V		165	250	$\mu\text{A}$
$I_{O(off)}$	Power-off RXD leakage current	$V_{CC}$ at 0 V, RXD at 5 V			20	$\mu\text{A}$
$C_I$	Input capacitance to ground (CANH or CANL)	TXD at 3 V, $V_I = 0.4 \sin(4E6\pi t) + 2.5\text{ V}$		13		pF
$C_{ID}$	Differential input capacitance	TXD at 3 V, $V_I = 0.4 \sin(4E6\pi t)$		6		pF
$R_{ID}$	Differential input resistance	TXD at 3 V, $S = 0\text{ V}$	30		80	k $\Omega$
$R_{IN}$	Input resistance (CANH or CANL)	TXD at 3 V, $S = 0\text{ V}$	15	30	40	k $\Omega$
$R_{I(m)}$	Input resistance matching $[1 - R_{IN(CANH)} / R_{IN(CANL)}] \times 100\%$	$V_{(CANH)} = V_{(CANL)}$	-3%	0%	3%	
<b>S PIN</b>						
$V_{IH}$	High-level input voltage, S input		2			V
$V_{IL}$	Low-level input voltage, S input				0.8	V
$I_{IH}$	High level input current	S at 2 V	20	40	70	$\mu\text{A}$
$I_{IL}$	Low level input current	S at 0.8 V	5	20	30	$\mu\text{A}$
<b>SPLIT (<math>V_{REF}</math>) PIN</b>						
$V_O$	Output voltage	$-50\text{ }\mu\text{A} < I_O < 50\text{ }\mu\text{A}$ ( $V_{REF}$ )	$0.4 V_{CC}$	$0.5 V_{CC}$	$0.6 V_{CC}$	V
		$-500\text{ }\mu\text{A} < I_O < 500\text{ }\mu\text{A}$ (SPLIT)	$0.3 V_{CC}$	$0.5 V_{CC}$	$0.7 V_{CC}$	
$I_{LKG}$	Leakage current, unpowered	$V_{CC} = 0\text{ V}$ , $-12\text{ V} \leq V_{SPLIT} \leq 12\text{ V}$	-5		5	$\mu\text{A}$

## 6.6 Power Dissipation Characteristics

over recommended operating conditions,  $T_A = -40$  to  $125^\circ\text{C}$  (unless otherwise noted)

PARAMETER	TEST CONDITIONS	MIN	TYP	MAX	UNIT
$P_D$ Average power dissipation	$V_{CC} = 5\text{ V}$ , $T_J = 27^\circ\text{C}$ , $R_L = 60\ \Omega$ , $S = 0\text{ V}$ , Input to TXD at 500 kHz, 50% duty cycle square wave, $C_L$ at RXD = 15 pF		112		mW
	$V_{CC} = 5.5\text{ V}$ , $T_J = 130^\circ\text{C}$ , $R_L = 45\ \Omega$ , $S = 0\text{ V}$ , Input to TXD at 500 kHz, 50% duty cycle square wave, $C_L$ at RXD = 15 pF			170	
Thermal shutdown temperature			190		$^\circ\text{C}$

## 6.7 Switching Characteristics

over operating free-air temperature range (unless otherwise noted)

PARAMETER	TEST CONDITIONS	MIN	TYP	MAX	UNIT
<b>SUPPLY</b>					
$t_{d(\text{LOOP}2)}$ Total loop delay, driver input to receiver output, dominant to recessive	$S = 0\text{ V}$ (see Figure 10)	90		230	ns
<b>DEVICE SWITCHING CHARACTERISTICS</b>					
$t_{d(\text{LOOP}1)}$ Total loop delay, driver input to receiver output, recessive to dominant	$S = 0\text{ V}$ (see Figure 10)	90		230	ns
$t_{d(\text{LOOP}2)}$ Total loop delay, driver input to receiver output, dominant to recessive	$S = 0\text{ V}$ (see Figure 10)	90		230	ns
<b>DRIVER SWITCHING CHARACTERISTICS</b>					
$t_{\text{PLH}}$ Propagation delay time, low-to-high level output	$S = 0\text{ V}$ (see Figure 5)	25	65	120	ns
$t_{\text{PHL}}$ Propagation delay time, high-to-low level output	$S = 0\text{ V}$ (see Figure 5)	25	45	120	ns
$t_r$ Differential output signal rise time	$S = 0\text{ V}$ (see Figure 5)		25		ns
$t_f$ Differential output signal fall time	$S = 0\text{ V}$ (see Figure 5)		50		ns
$t_{\text{en}}$ Enable time from silent mode to normal mode and transmission of dominant	See Figure 8			1	$\mu\text{s}$
$t_{(\text{dom})}$ Dominant time-out <sup>(1)</sup>	$\downarrow V_I$ (see Figure 11)	300	450	700	$\mu\text{s}$
<b>RECEIVER SWITCHING CHARACTERISTICS</b>					
$t_{\text{PLH}}$ Propagation delay time, low-to-high-level output	$S = 0\text{ V}$ or $V_{CC}$ (see Figure 7)	60	100	130	ns
$t_{\text{PHL}}$ Propagation delay time, high-to-low-level output	$S = 0\text{ V}$ or $V_{CC}$ (see Figure 7)	45	70	130	ns
$t_r$ Output signal rise time	$S = 0\text{ V}$ or $V_{CC}$ (see Figure 7)		8		ns
$t_f$ Output signal fall time	$S = 0\text{ V}$ or $V_{CC}$ (see Figure 7)		8		ns

- (1) The TXD dominant time out,  $t_{(\text{dom})}$ , disables the driver of the transceiver once the TXD has been dominant longer than  $t_{(\text{dom})}$ , which releases the bus lines to recessive, preventing a local failure from locking the bus dominant. The driver may only transmit dominant again after TXD has been returned HIGH (recessive). Although this protects the bus from local faults, locking the bus dominant, it limits the minimum data rate possible. The CAN protocol allows a maximum of eleven successive dominant bits (on TXD) for the worst case, where five successive dominant bits are followed immediately by an error frame. This, along with the  $t_{(\text{dom})}$  minimum, limits the minimum bit rate. The minimum bit rate may be calculated by: Minimum Bit Rate =  $11 / t_{(\text{dom})} = 11\text{ bits} / 300\ \mu\text{s} = 37\text{ kbps}$ .

**6.8 Typical Characteristics**

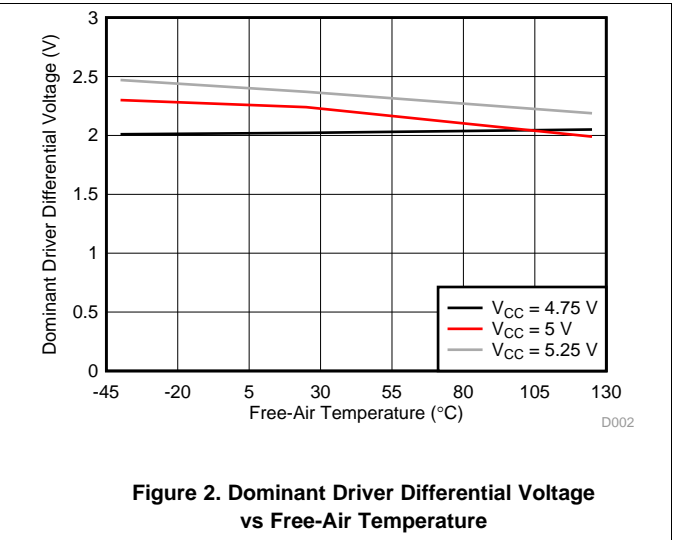
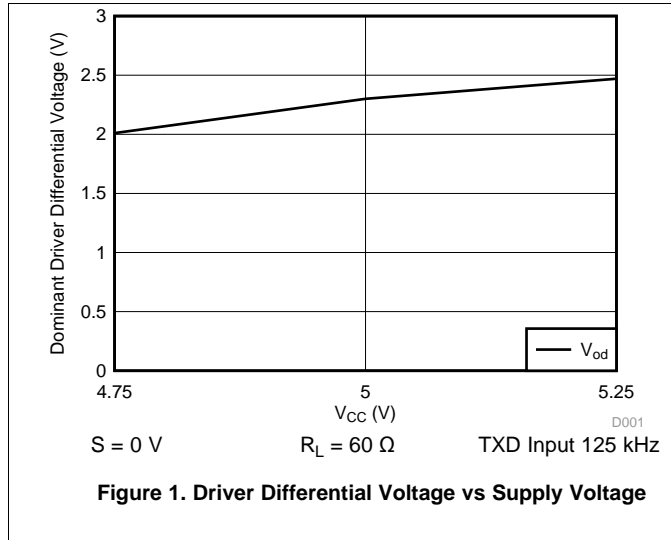



## 7 Parameter Measurement Information

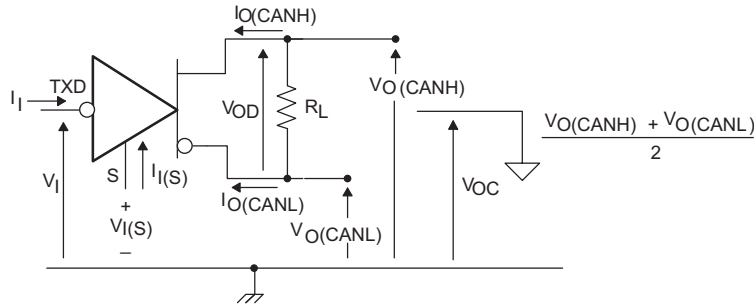

Figure 3. Driver Voltage, Current, and Test Definition

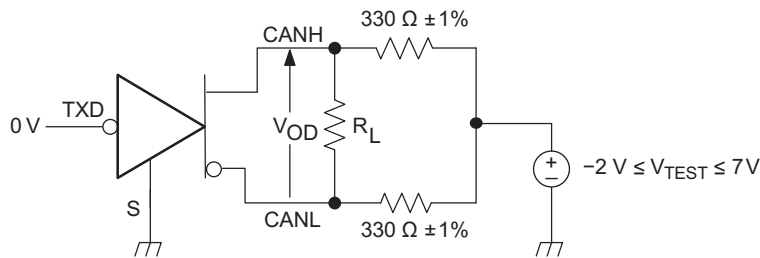
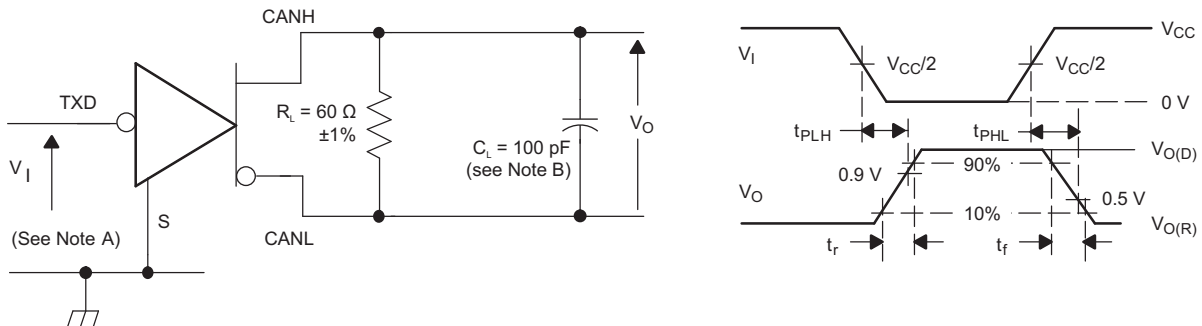

Figure 4. Driver VOD Test Circuit



- The input pulse is supplied by a generator having the following characteristics: PRR ≤ 125 kHz, 50% duty cycle,  $t_r \leq 6$  ns,  $t_f \leq 6$  ns,  $Z_0 = 50 \Omega$ .
- $C_L$  includes instrumentation and fixture capacitance within ±20%.

Figure 5. Driver Test Circuit and Voltage Waveforms

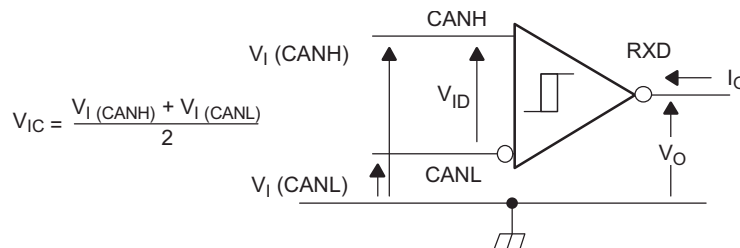
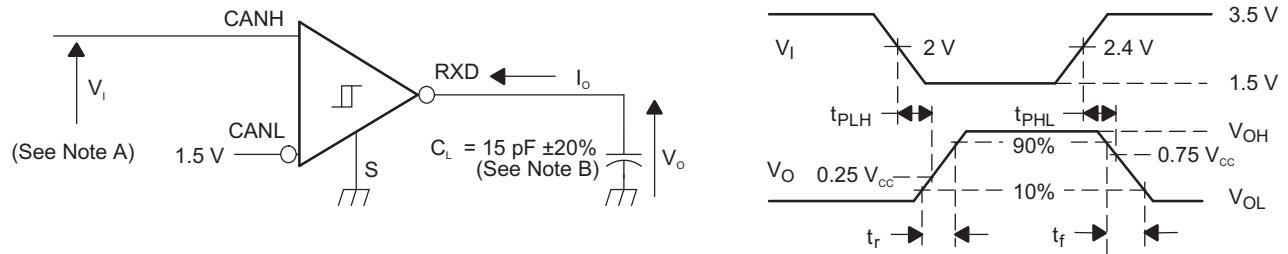

Figure 6. Receiver Voltage and Current Definitions

**Parameter Measurement Information (continued)**

- A. The input pulse is supplied by a generator having the following characteristics: PRR  $\leq$  125 kHz, 50% duty cycle,  $t_r \leq$  6 ns,  $t_f \leq$  6 ns,  $Z_0 = 50 \Omega$ .
- B.  $C_L$  includes instrumentation and fixture capacitance within  $\pm 20\%$ .

**Figure 7. Receiver Test Circuit and Voltage Waveforms**
**Table 1. Differential Input Voltage Threshold Test**

INPUT			OUTPUT R
$V_{CANH}$	$V_{CANL}$	$ V_{ID} $	
-11.1 V	-12 V	900 mV	L
12 V	11.1 V	900 mV	L
-6 V	-12 V	6 V	L
12 V	6 V	6 V	L
-11.5 V	-12 V	500 mV	H
12 V	11.5 V	500 mV	H
-12 V	-6 V	6 V	H
6 V	12 V	6 V	H
Open	Open	X	H

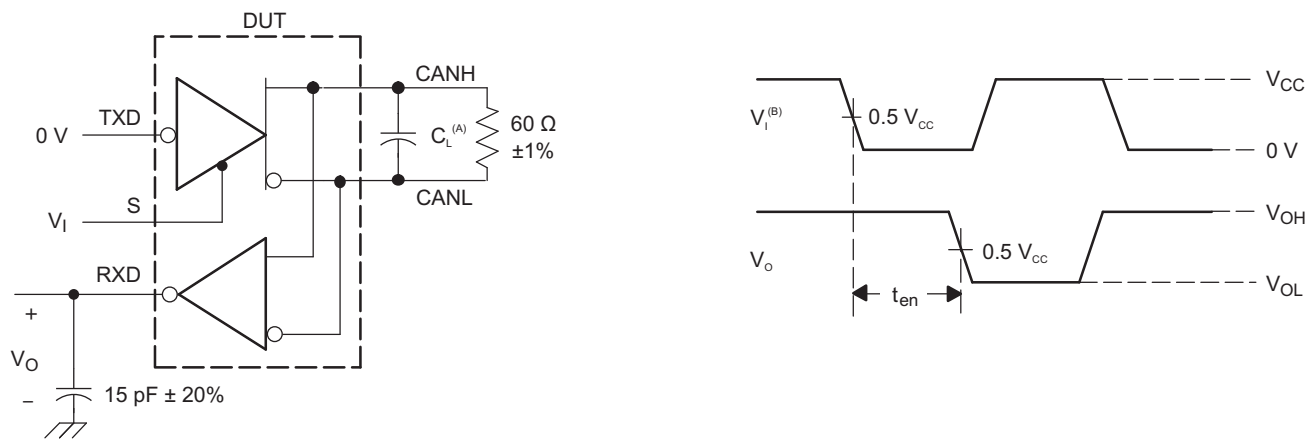

- A.  $C_L = 100 \text{ pF}$  and includes instrumentation and fixture capacitance within  $\pm 20\%$ .
- B. All  $V_I$  input pulses are supplied by a generator having the following characteristics:  $t_r$  or  $t_f \leq$  6 ns, pulse repetition rate (PRR) = 125 kHz, 50% duty cycle.

**Figure 8.  $t_{en}$  Test Circuit and Waveforms**

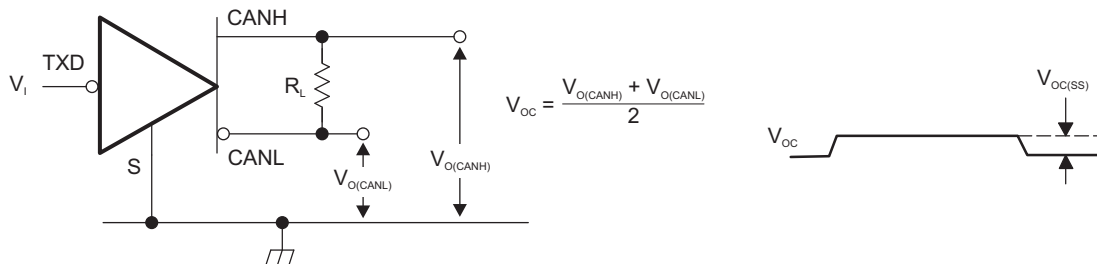

NOTE: All  $V_1$  input pulses are from 0 V to  $V_{CC}$  and supplied by a generator having the following characteristics:  $t_r$  or  $t_f \leq 6$  ns, pulse repetition rate (PRR) = 125 kHz, 50% duty cycle.

Figure 9. Common-Mode Output Voltage Test and Waveforms

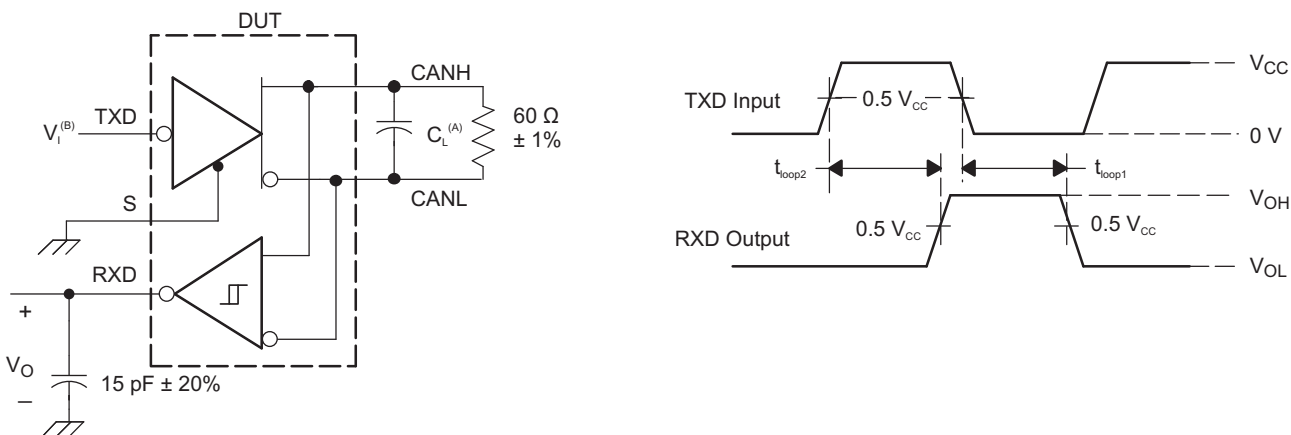

- A.  $C_L = 100$  pF and includes instrumentation and fixture capacitance within  $\pm 20\%$ .
- B. All  $V_1$  input pulses are from 0 V to  $V_{CC}$  and supplied by a generator having the following characteristics:  $t_r$  or  $t_f \leq 6$  ns, pulse repetition rate (PRR) = 125 kHz, 50% duty cycle.

Figure 10.  $t_{LOOP}$  Test Circuit and Waveforms

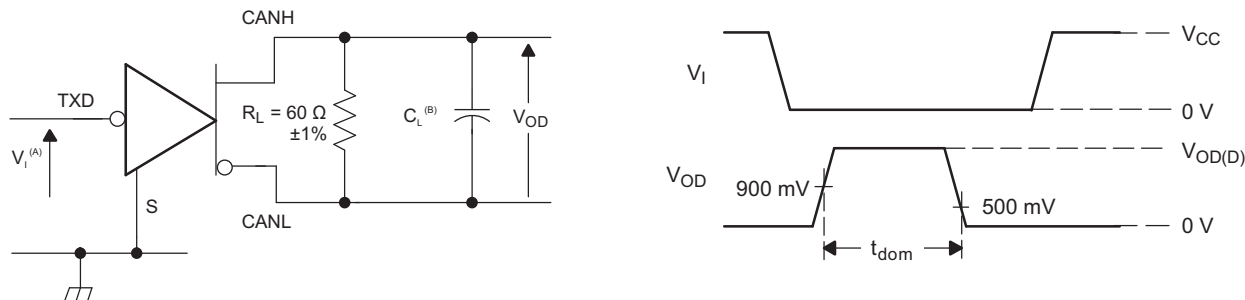

- A. All  $V_1$  input pulses are from 0 V to  $V_{CC}$  and supplied by a generator having the following characteristics:  $t_r$  or  $t_f \leq 6$  ns, pulse repetition rate (PRR) = 500 Hz, 50% duty cycle.
- B.  $C_L = 100$  pF includes instrumentation and fixture capacitance within  $\pm 20\%$ .

Figure 11. Dominant Time-Out Test Circuit and Waveforms

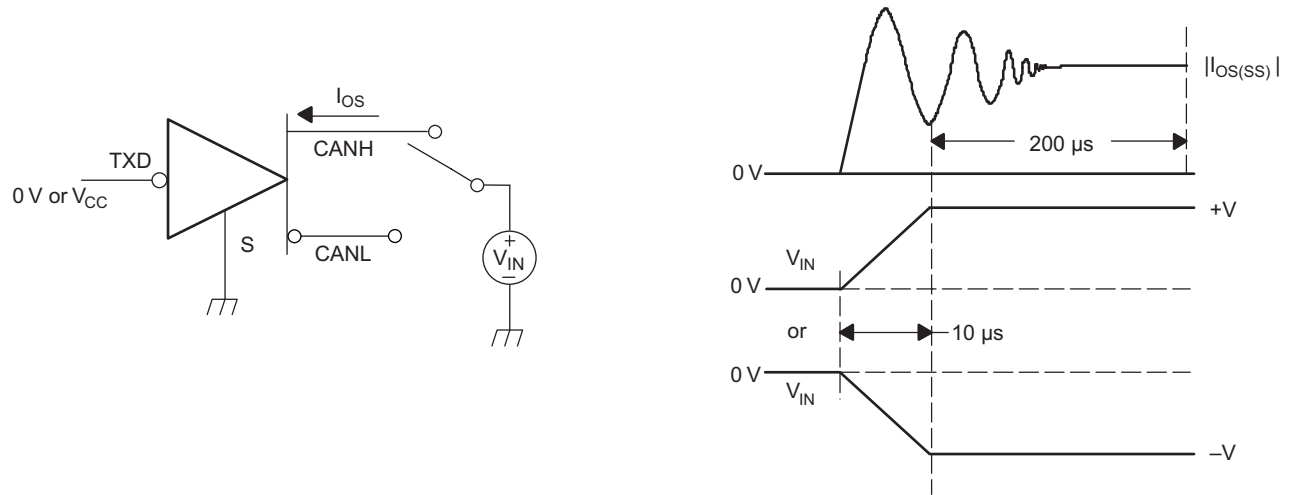

**Figure 12. Driver Short-Circuit Current Test and Waveforms**

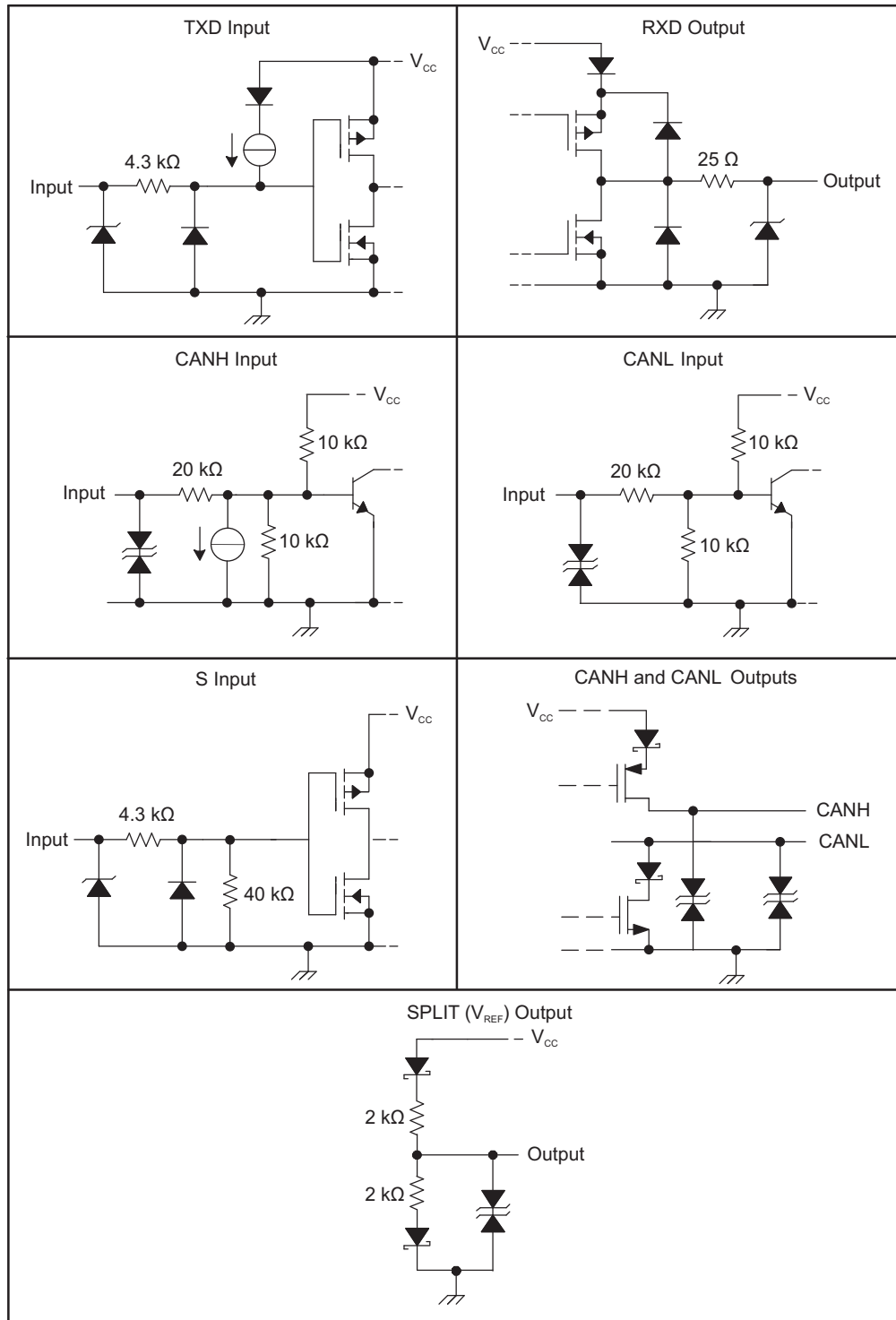

Figure 13. Equivalent Input and Output Schematic Diagrams

## 8 Detailed Description

### 8.1 Overview

The SN65HVDA1050A-Q1 CAN transceiver is compatible with the ISO 11898-2 high-speed controller area network (CAN) physical layer standard. The device is designed to interface between the differential bus lines in controller area network and the CAN protocol controller at data rates up to 1 Mbps.

### 8.2 Functional Block Diagram

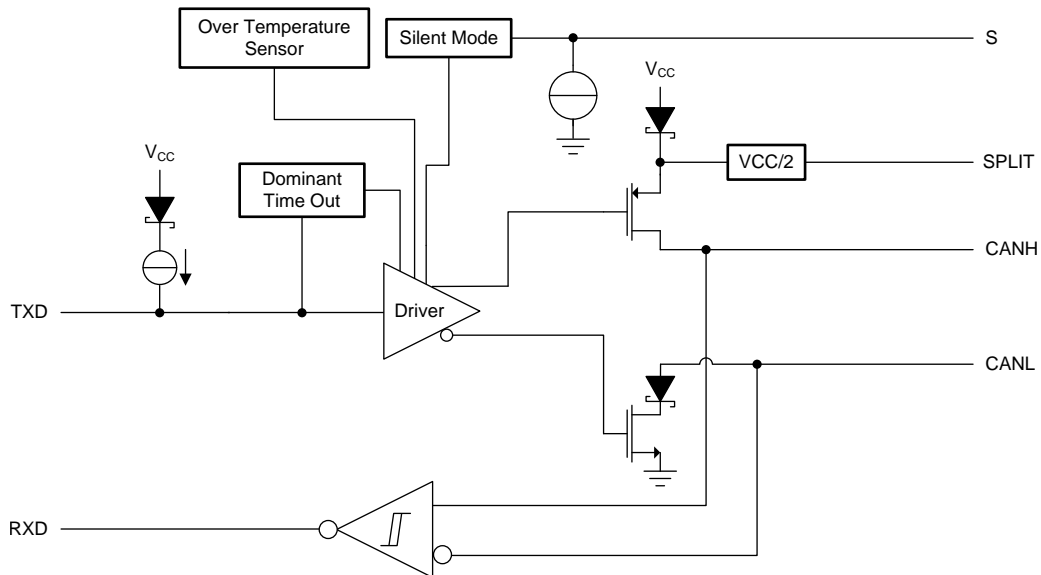

### 8.3 Feature Description

#### 8.3.1 Operating Modes

The device has two main operating modes: normal mode and silent mode. Operating mode selection is made through the S input pin.

**Table 2. Operating Modes**

S PIN	MODE	DRIVER	RECEIVER	RXD PIN
LOW	Normal	Enabled (On)	Enabled (On)	Mirrors CAN bus
HIGH	Silent	Disabled (Off)	Enabled (On)	Mirrors CAN bus

##### 8.3.1.1 Normal Mode

This is the normal operating mode of the device. Normal mode is selected by setting S low. The CAN driver and receiver are fully operational and CAN communication is bidirectional. The driver is translating a digital input on TXD to a differential output on CANH and CANL. The receiver is translating the differential signal from CANH and CANL to a digital output on RXD. In recessive state, the bus pins are biased to  $0.5 \times V_{CC}$ . In dominant state, the bus pins (CANH and CANL) are driven differentially apart. Logic high is equivalent to recessive on the bus and logic low is equivalent to a dominant (differential) signal on the bus.

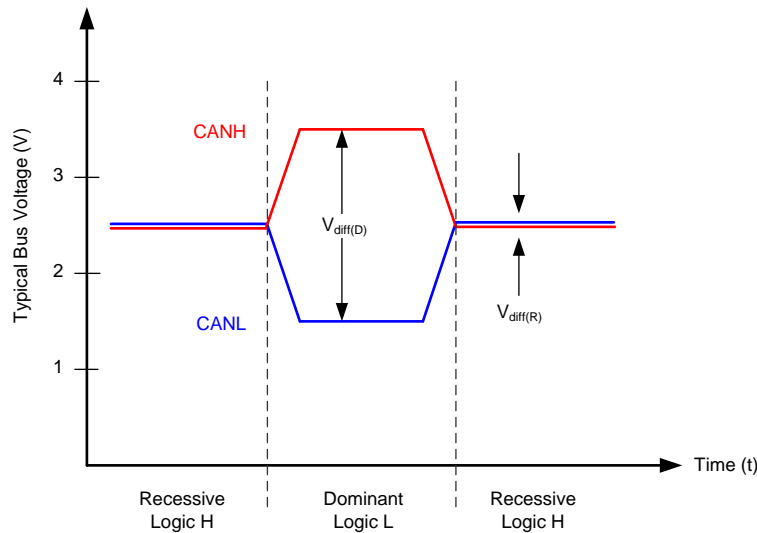

Figure 14. Bus Logic-State Voltage Definitions

The SPLIT ( $V_{REF}$ ) pin is biased to  $0.5 \times V_{CC}$  for bus common mode bus voltage bias stabilization in split termination network applications (see [Application and Implementation](#)).

### 8.3.1.2 Silent Mode

Silent mode disables the driver (transmitter) of the device; however, the receiver still operates and translates the differential signal from CANH and CANL to the digital output on RXD. It is selected by setting S high. The bus pins (CANH and CANL) are biased to  $0.5 \times V_{CC}$ . The SPLIT ( $V_{REF}$ ) pin is biased to  $0.5 \times V_{CC}$ .

## 8.3.2 Protection Features

### 8.3.2.1 TXD Dominant State Timeout

During normal mode operation (the only mode where the CAN driver is active), the TXD dominant time-out circuit prevents the transceiver from blocking network communication in the event of a hardware or software failure where TXD is held dominant longer than the time-out period,  $t_{DST}$ . The dominant time-out circuit is triggered by a falling edge on TXD. If no rising edge occurs before the time-out constant of the circuit expires ( $t_{DST}$ ), the CAN bus driver is disabled, thus freeing the bus for communication between other network nodes. The CAN driver is reactivated when a recessive signal occurs on the TXD pin, thus clearing the dominant-state time-out. The CAN bus pins are biased to recessive level during a TXD dominant-state time-out, and SPLIT ( $V_{REF}$ ) remains on.

#### NOTE

The maximum dominant TXD time allowed by the TXD dominant state time-out limits the minimum possible data rate of the device. The CAN protocol allows a maximum of eleven successive dominant bits (on TXD) for the worst case, where five successive dominant bits are followed immediately by an error frame. This, along with the  $t_{(dom)}$  minimum, limits the minimum bit rate. The minimum bit rate may be calculated by:

$$\text{Minimum Bit Rate} = 11 / t_{(dom)}$$

### 8.3.2.2 Thermal Shutdown

If the junction temperature of the device exceeds the thermal-shutdown threshold, the device turns off the CAN driver circuits. The SPLIT ( $V_{REF}$ ) pin remains biased. This condition is cleared when the temperature drops below the thermal-shutdown temperature of the device.

### 8.3.2.3 Undervoltage Lockout and Unpowered Device

The device has undervoltage detection and lockout on the  $V_{CC}$  supply. If an undervoltage condition is detected on  $V_{CC}$ , the device protects the bus.

The TXD pin is pulled up to  $V_{CC}$  to force a recessive input level if the pin floats. The S pin is pulled up to GND to force the device into normal mode if the pin floats.

The bus pins [CANH, CANL, and SPLIT ( $V_{REF}$ )] all have low leakage currents when the device is unpowered.

## 8.4 Device Functional Modes

**Table 3. Driver Function Table<sup>(1)</sup>**

INPUTS		OUTPUTS		BUS STATE
TXD	S	CANH	CANL	
L	L or Open	H	L	Dominant
H	X	Z	Z	Recessive
Open	X	Z	Z	Recessive
X	H	Z	Z	Recessive

(1) H = high level, L = low level, X = irrelevant, ? = indeterminate, Z = high impedance

**Table 4. Receiver Function Table<sup>(1)</sup>**

DIFFERENTIAL INPUTS $V_{ID} = V(\text{CANH}) - V(\text{CANL})$	OUTPUT RXD	BUS STATE
$V_{ID} \geq 0.9 \text{ V}$	L	Dominant
$0.5 \text{ V} < V_{ID} < 0.9 \text{ V}$	?	?
$V_{ID} \leq 0.5 \text{ V}$	H	Recessive
Open	H	Recessive

(1) H = high level, L = low level, X = irrelevant, ? = indeterminate, Z = high impedance



## 9 Application and Implementation

### NOTE

Information in the following applications sections is not part of the TI component specification, and TI does not warrant its accuracy or completeness. TI's customers are responsible for determining suitability of components for their purposes. Customers should validate and test their design implementation to confirm system functionality.

### 9.1 Application Information

#### 9.1.1 Using the Device With 3.3-V Microcontrollers

The input level threshold for the digital input pins of this device is 3.3-V compatible; however, a few application considerations must be taken when using this device with 3.3-V microcontrollers. The TXD input pin has an internal pullup source to  $V_{CC}$ . Some microcontroller vendors recommend using an open-drain configuration on their I/O pins in this case, even though the pullup limits the current. As such, care must be taken at the application level that TXD has sufficient pullup to meet system timing requirements for CAN. The internal pullup on TXD especially may not be sufficient to overcome the parasitic capacitances and allow for adequate CAN timing; thus, an additional external pullup may be required. Care must also be taken with the RXD pin of the microcontroller, as the RXD output of this device drives the full  $V_{CC}$  range (5 V). If the microcontroller RXD input pin is not 5-V tolerant, this must be addressed at the application level. Other options include using a CAN transceiver from Texas Instruments with I/O level adapting or a 3.3-V CAN transceiver.

#### 9.1.2 Using SPLIT ( $V_{REF}$ ) With Split Termination

The SPLIT ( $V_{REF}$ ) pin voltage output provides  $0.5 \times V_{CC}$  in normal mode. This pin is specified for both the SPLIT sink/source current condition and the  $V_{REF}$  sink/source current condition. The circuit may be used by the application to stabilize the common-mode voltage of the bus by connecting it to the center tap of split termination for the CAN network (see Figure 15). The SPLIT ( $V_{REF}$ ) pin provides a stabilizing recessive voltage drive to offset leakage currents of unpowered transceivers or other bias imbalances that might bring the network common-mode voltage away from  $0.5 \times V_{CC}$ . Using this feature in a CAN network improves the electromagnetic-emissions behavior of the network by eliminating fluctuations in the bus common-mode voltage levels at the start of message transmissions.

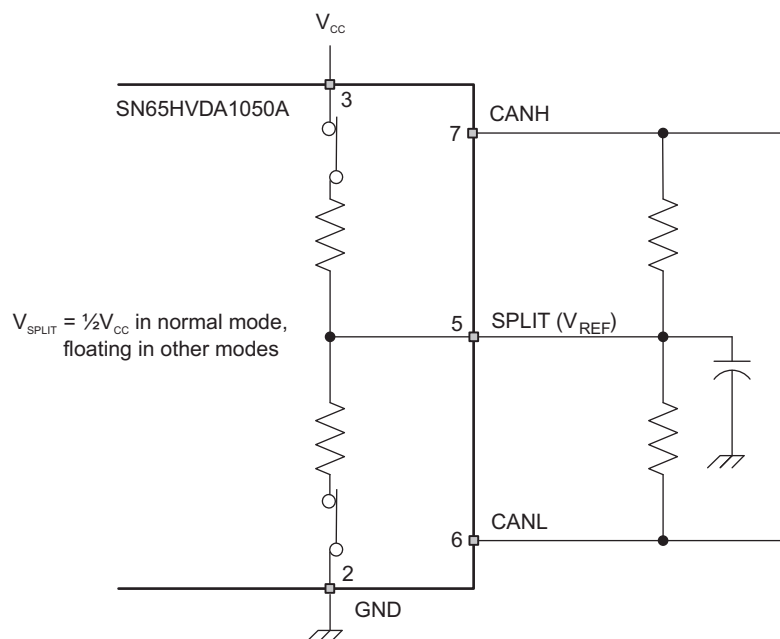

Figure 15. SPLIT Pin Stabilization Circuitry and Application

## 9.2 Typical Application

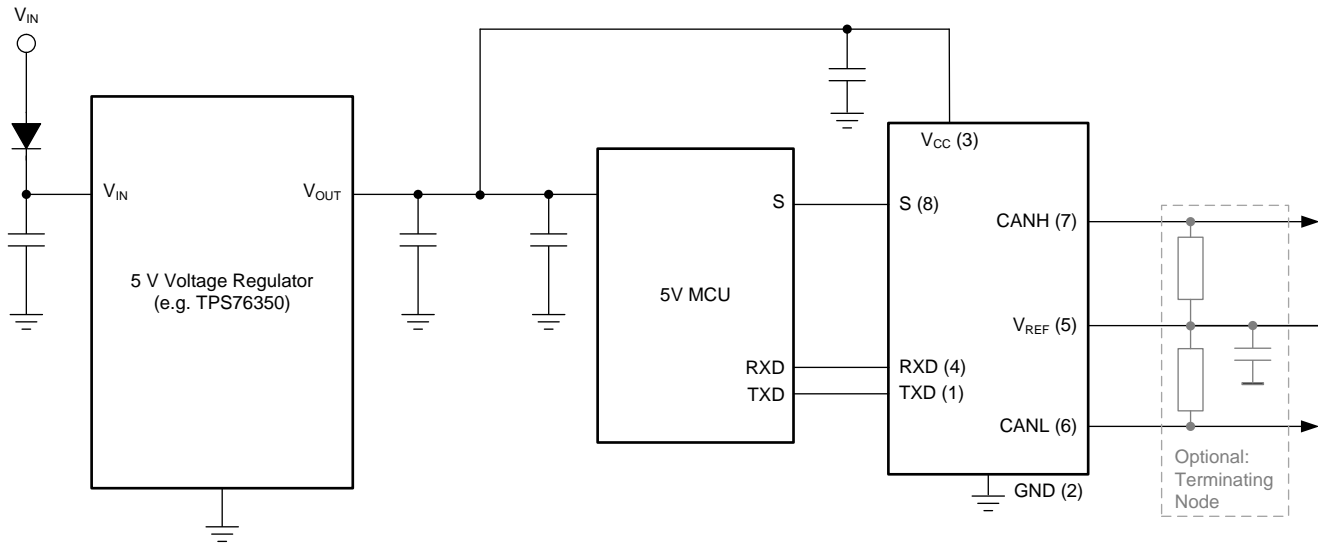

Figure 16. Typical Application Using Split Termination for Stabilization

### 9.2.1 Design Requirements

#### 9.2.1.1 Bus Loading, Length, and Number of Nodes

The ISO 11898 Standard specifies up to 1-Mbps data rate, a maximum bus length of 40 meters, a maximum drop-line (stub) length of 0.3 meters, and a maximum of 30 nodes. However, with careful network design, the system may have longer cables, longer stub lengths, and many more nodes to a bus. Many CAN organizations and standards have scaled the use of CAN for applications outside the original ISO 11898 standard. They have made system-level trade-offs for data rate, cable length, and parasitic loading of the bus. Examples of some of these specifications are ARINC825, CANopen, CAN Kingdom, DeviceNet, and NMEA200 (see Figure 17).

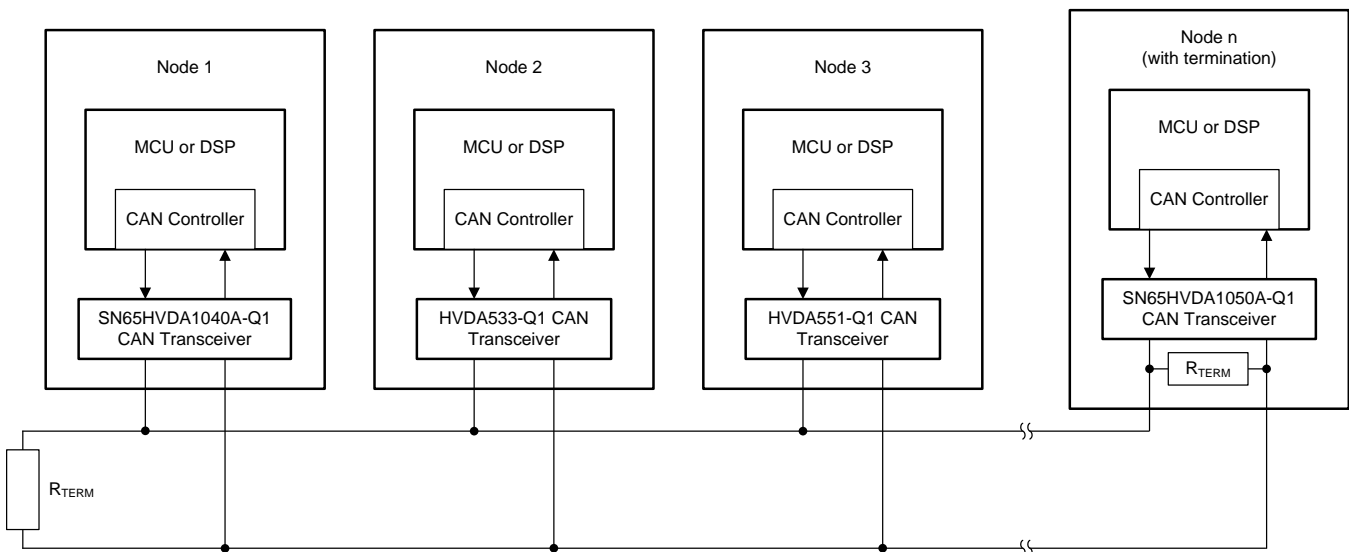

Figure 17. Typical CAN Bus

## Typical Application (continued)

A high number of nodes requires a transceiver with high input impedance and wide common-mode range, such as the SN65HVDA1050A-Q1 CAN transceiver. ISO 11898-2 specifies that the driver differential output with a 60- $\Omega$  load (two 120- $\Omega$  termination resistors in parallel) and the differential output must be greater than 1.5 V. The SN65HVDA1050A-Q1 device is specified to meet the 1.5-V requirement with a 60- $\Omega$  load, and additionally specified with a differential output voltage minimum of 1.2 V across a common-mode range of -2 V to 7 V through a 330- $\Omega$  coupling network. This network represents the bus loading of 90 SN65HVDA1050A-Q1 transceivers based on their minimum differential input resistance of 30 k $\Omega$ . Therefore, the SN65HVDA1050A-Q1 supports up to 90 transceivers on a single bus segment with margin to the 1.2-V minimum differential input voltage requirement at each node.

For CAN network design, margin must be given for signal loss across the system and cabling, parasitic loadings, network imbalances, ground offsets, and signal integrity; thus the practical maximum number of nodes may be lower. Bus length may also be extended beyond the original ISO 11898 standard of 40 meters by careful system design and data rate tradeoffs. For example, CANopen network design guidelines allow the network to be up to 1-km with changes in the termination resistance, cabling, less than 64 nodes, and a significantly lowered data rate.

This flexibility in CAN network design is one of the key strengths of the various extensions and additional standards that have been built on the original ISO 11898 CAN standard.

### 9.2.1.2 CAN Termination

The ISO 11898 standard specifies the interconnect to be a twisted-pair cable (shielded or unshielded) with 120- $\Omega$  characteristic impedance ( $Z_0$ ). Resistors equal to the characteristic impedance of the line must be used to terminate both ends of the cable to prevent signal reflections. Unterminated drop lines (stubs) connecting nodes to the bus must be kept as short as possible to minimize signal reflections. The termination may be on the cable or in a node, but if nodes may be removed from the bus, the termination must be carefully placed so it is not removed from the bus.

Termination is typically a 120- $\Omega$  resistor at each end of the bus. If filtering and stabilization of the common-mode voltage of the bus is desired, then split termination may be used (see [Figure 18](#) and [Using SPLIT \( \$V\_{REF}\$ \) With Split Termination](#)).

Care must be taken when determining the power ratings of the termination resistors. A typical worst case fault condition is when the system power supply and ground are shorted across the termination resistance, which results in much higher current through the termination resistance than the current limit of the CAN transceiver.

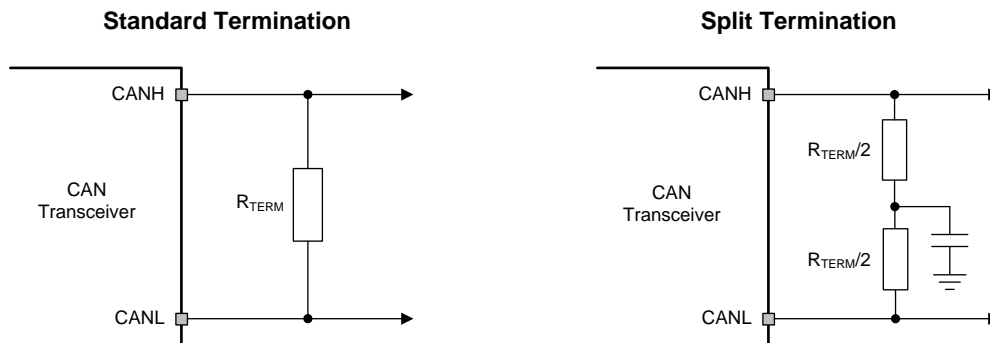

Figure 18. CAN Termination Scheme

### 9.2.1.3 Loop Propagation Delay

Transceiver loop delay is a measure of the overall device propagation delay, consisting of the delay from the driver input (the TXD pin) to the differential outputs (the CANH and CANL pins), plus the delay from the receiver inputs (the CANH and CANL) to its output (the RXD pin). A typical loop delay for the SN65HVDA1050A-Q1 transceiver is displayed in [Figure 20](#) and [Figure 21](#).

## Typical Application (continued)

### 9.2.2 Detailed Design Procedure

#### 9.2.2.1 ESD Protection

A typical application that employs a CAN-bus network may require some form of ESD, burst, and surge protection to shield the CAN transceiver against unwanted transients, which could cause potential damage to the transceiver. To help shield the SN65HVDA1050A-Q1 transceiver against these high energy transients, transient voltage suppressors can be implemented on the CAN differential bus terminals. These devices help to absorb the impact of an ESD, burst, and/or surge strike.

#### 9.2.2.2 Transient Voltage Suppressor (TVS) Diodes

Transient voltage suppressors are the preferred protection components for a CAN bus due to their low capacitance, which allows for design into every node of a multi-node network without requiring a reduction in data rate (see Figure 19). With response times of a few picoseconds and power ratings of up to several kilowatts, TVS diodes present the most effective protection against ESD, burst, and surge transients.

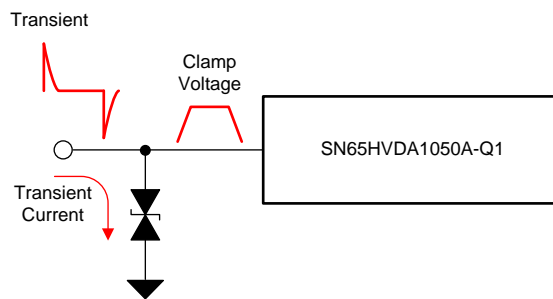

Figure 19. Transient

### 9.2.3 Application Curves

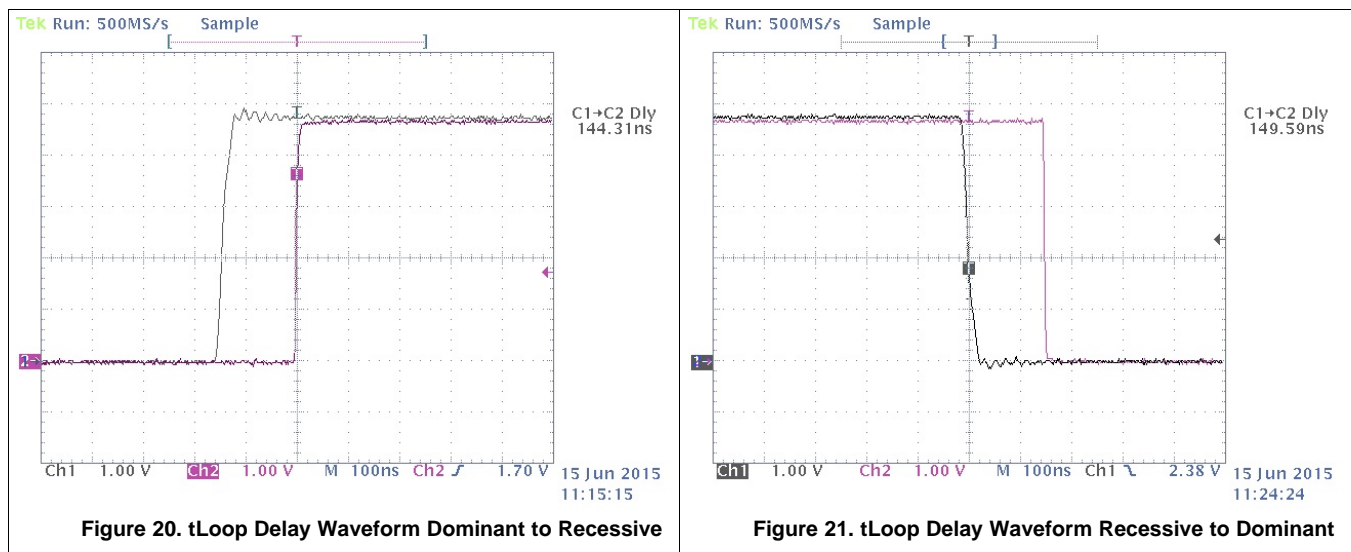

Figure 20. tLoop Delay Waveform Dominant to Recessive

Figure 21. tLoop Delay Waveform Recessive to Dominant

## 10 Power Supply Recommendations

To ensure reliable operation at all data rates and supply voltages, each supply must be decoupled with a 100-nF ceramic capacitor located as close as possible to the  $V_{CC}$  supply pins. One option is the TPS76350 device, which is a linear voltage regulator that is suitable for the 5-V supply rail.

## 11 Layout

### 11.1 Layout Guidelines

In order for the PCB design to be successful, start with a design of the protection and filtering circuitry. Because ESD and EFT transients have a wide frequency bandwidth from approximately 3 MHz to 3 GHz, high-frequency layout techniques must be applied during PCB design. On-chip IEC ESD protection is good for laboratory and portable equipment, but it is usually not sufficient for EFT and surge transients occurring in industrial environments. Therefore, robust and reliable bus node design requires the use of external transient protection devices at the bus connectors. Placement at the connector also prevents these harsh transient events from propagating further into the PCB and system.

Use  $V_{CC}$  and ground planes to provide low inductance.

---

#### NOTE

High-frequency current follows the path of least inductance and not the path of least resistance.

---

Design the bus protection components in the direction of the signal path. Do not force the transient current to divert from the signal path to reach the protection device. An example placement of the transient voltage suppressor (TVS) device indicated as D1 (either bidirectional diode or varistor solution) and bus filter capacitors C5 and C7 are shown in [Figure 22](#).

The bus transient protection and filtering components must be placed as close to the bus connector, J1, as possible. This prevents transients, ESD and noise from penetrating onto the board and disturbing other devices.

Bus termination: [Figure 22](#) shows split termination, which is where the termination is split into two resistors, R5 and R6, with the center or split tap of the termination connected to ground through capacitor C6. Split termination provides common-mode filtering for the bus. When termination is placed on the board instead of directly on the bus, care must be taken to ensure that the terminating node is not removed from the bus because this causes signal integrity issues if the bus is not properly terminated on both ends. Bypass and bulk capacitors must be placed as close as possible to the supply pins of transceiver, examples include C2 and C3 ( $V_{CC}$ ).

Use at least two vias for  $V_{CC}$  and ground connections of bypass capacitors and protection devices to minimize trace and via inductance.

To limit the current of digital lines, serial resistors may be used. Examples are R1, R2, R3, and R4.

To filter noise on the digital I/O lines, a capacitor may be used close to the input side of the I/O as shown by C1 and C4.

Because the internal pullup and pulldown biasing of the device is weak for floating pins, an external 1-k $\Omega$  to 10-k $\Omega$  pullup or pulldown resistor must be used to bias the state of the pin more strongly against noise during transient events.

Pin 1: If an open-drain host processor is used to drive the TXD pin of the device, an external pullup resistor between 1 k $\Omega$  and 10 k $\Omega$  must be used to drive the recessive input state of the device.

Pin 5: SPLIT must be connected to the center point of a split termination scheme to help stabilize the common-mode voltage to  $V_{CC} / 2$ . If SPLIT is unused, it must be left floating.

Pin 8: Is shown assuming the mode pin, STB, is used. If the device is only to be used in normal mode, R3 is not needed, and the pads of C4 could be used for the pulldown resistor to GND

11.2 Layout Example

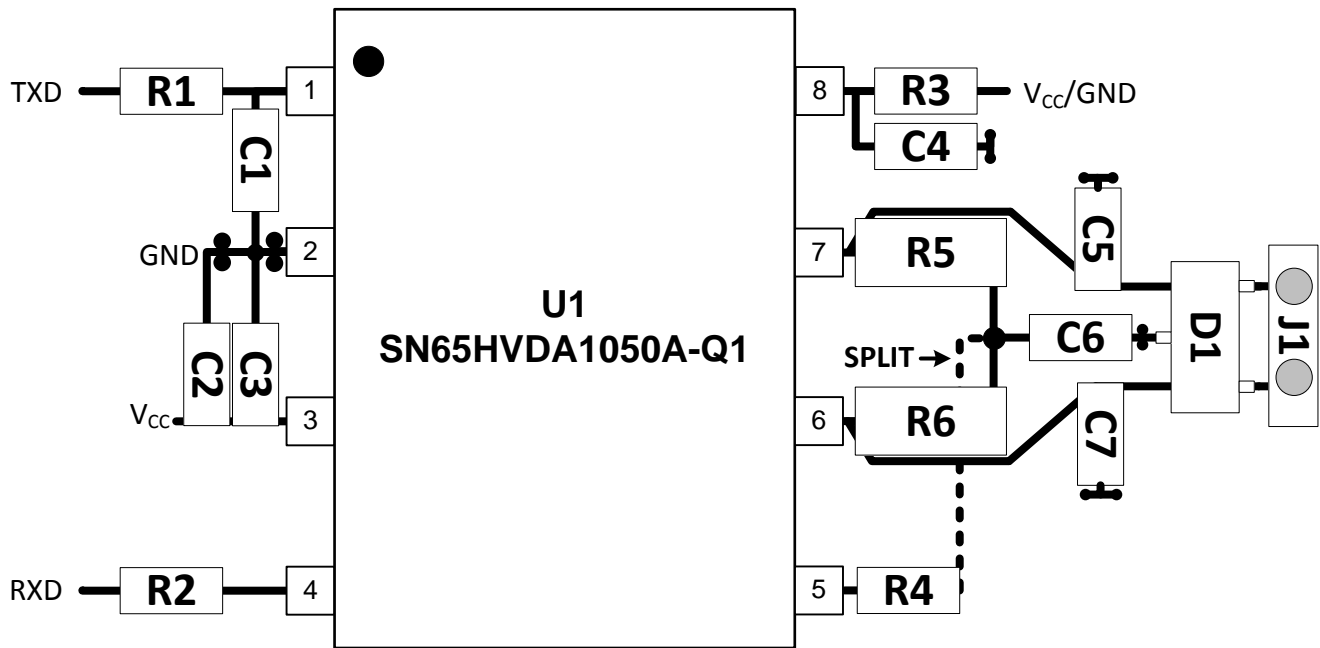

Figure 22. Layout

## 12 Device and Documentation Support

### 12.1 Community Resources

The following links connect to TI community resources. Linked contents are provided "AS IS" by the respective contributors. They do not constitute TI specifications and do not necessarily reflect TI's views; see TI's [Terms of Use](#).

**TI E2E™ Online Community** *TI's Engineer-to-Engineer (E2E) Community*. Created to foster collaboration among engineers. At [e2e.ti.com](http://e2e.ti.com), you can ask questions, share knowledge, explore ideas and help solve problems with fellow engineers.

**Design Support** *TI's Design Support* Quickly find helpful E2E forums along with design support tools and contact information for technical support.

### 12.2 Trademarks

E2E is a trademark of Texas Instruments.  
All other trademarks are the property of their respective owners.

### 12.3 Electrostatic Discharge Caution



These devices have limited built-in ESD protection. The leads should be shorted together or the device placed in conductive foam during storage or handling to prevent electrostatic damage to the MOS gates.

### 12.4 Glossary

[SLYZ022](#) — *TI Glossary*.

This glossary lists and explains terms, acronyms, and definitions.

## 13 Mechanical, Packaging, and Orderable Information

The following pages include mechanical, packaging, and orderable information. This information is the most current data available for the designated devices. This data is subject to change without notice and revision of this document. For browser-based versions of this data sheet, refer to the left-hand navigation.

## PACKAGING INFORMATION

Orderable Device	Status (1)	Package Type	Package Drawing	Pins	Package Qty	Eco Plan (2)	Lead/Ball Finish	MSL Peak Temp (3)	Op Temp (°C)	Top-Side Markings (4)	Samples
SN65HVDA1050AQDRQ1	ACTIVE	SOIC	D	8	2500	Green (RoHS & no Sb/Br)	CU NIPDAU	Level-1-260C-UNLIM	-40 to 125	A1050A	<a href="#">Samples</a>

(1) The marketing status values are defined as follows:

**ACTIVE:** Product device recommended for new designs.

**LIFEBUY:** TI has announced that the device will be discontinued, and a lifetime-buy period is in effect.

**NRND:** Not recommended for new designs. Device is in production to support existing customers, but TI does not recommend using this part in a new design.

**PREVIEW:** Device has been announced but is not in production. Samples may or may not be available.

**OBSOLETE:** TI has discontinued the production of the device.

(2) Eco Plan - The planned eco-friendly classification: Pb-Free (RoHS), Pb-Free (RoHS Exempt), or Green (RoHS & no Sb/Br) - please check <http://www.ti.com/productcontent> for the latest availability information and additional product content details.

**TBD:** The Pb-Free/Green conversion plan has not been defined.

**Pb-Free (RoHS):** TI's terms "Lead-Free" or "Pb-Free" mean semiconductor products that are compatible with the current RoHS requirements for all 6 substances, including the requirement that lead not exceed 0.1% by weight in homogeneous materials. Where designed to be soldered at high temperatures, TI Pb-Free products are suitable for use in specified lead-free processes.

**Pb-Free (RoHS Exempt):** This component has a RoHS exemption for either 1) lead-based flip-chip solder bumps used between the die and package, or 2) lead-based die adhesive used between the die and leadframe. The component is otherwise considered Pb-Free (RoHS compatible) as defined above.

**Green (RoHS & no Sb/Br):** TI defines "Green" to mean Pb-Free (RoHS compatible), and free of Bromine (Br) and Antimony (Sb) based flame retardants (Br or Sb do not exceed 0.1% by weight in homogeneous material)

(3) MSL, Peak Temp. -- The Moisture Sensitivity Level rating according to the JEDEC industry standard classifications, and peak solder temperature.

(4) Multiple Top-Side Markings will be inside parentheses. Only one Top-Side Marking contained in parentheses and separated by a "~" will appear on a device. If a line is indented then it is a continuation of the previous line and the two combined represent the entire Top-Side Marking for that device.

**Important Information and Disclaimer:** The information provided on this page represents TI's knowledge and belief as of the date that it is provided. TI bases its knowledge and belief on information provided by third parties, and makes no representation or warranty as to the accuracy of such information. Efforts are underway to better integrate information from third parties. TI has taken and continues to take reasonable steps to provide representative and accurate information but may not have conducted destructive testing or chemical analysis on incoming materials and chemicals. TI and TI suppliers consider certain information to be proprietary, and thus CAS numbers and other limited information may not be available for release.

In no event shall TI's liability arising out of such information exceed the total purchase price of the TI part(s) at issue in this document sold by TI to Customer on an annual basis.



## TAPE AND REEL INFORMATION



### QUADRANT ASSIGNMENTS FOR PIN 1 ORIENTATION IN TAPE



\*All dimensions are nominal

Device	Package Type	Package Drawing	Pins	SPQ	Reel Diameter (mm)	Reel Width W1 (mm)	A0 (mm)	B0 (mm)	K0 (mm)	P1 (mm)	W (mm)	Pin1 Quadrant
SN65HVDA1050AQDRQ1	SOIC	D	8	2500	330.0	12.4	6.4	5.2	2.1	8.0	12.0	Q1
SN65HVDA1050AQDRQ1	SOIC	D	8	2500	330.0	12.4	6.4	5.2	2.1	8.0	12.0	Q1

TAPE AND REEL BOX DIMENSIONS



\*All dimensions are nominal

Device	Package Type	Package Drawing	Pins	SPQ	Length (mm)	Width (mm)	Height (mm)
SN65HVDA1050AQDRQ1	SOIC	D	8	2500	367.0	367.0	35.0
SN65HVDA1050AQDRQ1	SOIC	D	8	2500	367.0	367.0	38.0

D (R-PDSO-G8)

PLASTIC SMALL OUTLINE



4040047-3/M 06/11

D (R-PDSO-G8)

PLASTIC SMALL OUTLINE



4211283-2/E 08/12

- NOTES:
- A. All linear dimensions are in millimeters.
  - B. This drawing is subject to change without notice.
  - C. Publication IPC-7351 is recommended for alternate designs.
  - D. Laser cutting apertures with trapezoidal walls and also rounding corners will offer better paste release. Customers should contact their board assembly site for stencil design recommendations. Refer to IPC-7525 for other stencil recommendations.
  - E. Customers should contact their board fabrication site for solder mask tolerances between and around signal pads.

## IMPORTANT NOTICE

Texas Instruments Incorporated and its subsidiaries (TI) reserve the right to make corrections, enhancements, improvements and other changes to its semiconductor products and services per JESD46, latest issue, and to discontinue any product or service per JESD48, latest issue. Buyers should obtain the latest relevant information before placing orders and should verify that such information is current and complete. All semiconductor products (also referred to herein as "components") are sold subject to TI's terms and conditions of sale supplied at the time of order acknowledgment.

TI warrants performance of its components to the specifications applicable at the time of sale, in accordance with the warranty in TI's terms and conditions of sale of semiconductor products. Testing and other quality control techniques are used to the extent TI deems necessary to support this warranty. Except where mandated by applicable law, testing of all parameters of each component is not necessarily performed.

TI assumes no liability for applications assistance or the design of Buyers' products. Buyers are responsible for their products and applications using TI components. To minimize the risks associated with Buyers' products and applications, Buyers should provide adequate design and operating safeguards.

TI does not warrant or represent that any license, either express or implied, is granted under any patent right, copyright, mask work right, or other intellectual property right relating to any combination, machine, or process in which TI components or services are used. Information published by TI regarding third-party products or services does not constitute a license to use such products or services or a warranty or endorsement thereof. Use of such information may require a license from a third party under the patents or other intellectual property of the third party, or a license from TI under the patents or other intellectual property of TI.

Reproduction of significant portions of TI information in TI data books or data sheets is permissible only if reproduction is without alteration and is accompanied by all associated warranties, conditions, limitations, and notices. TI is not responsible or liable for such altered documentation. Information of third parties may be subject to additional restrictions.

Resale of TI components or services with statements different from or beyond the parameters stated by TI for that component or service voids all express and any implied warranties for the associated TI component or service and is an unfair and deceptive business practice. TI is not responsible or liable for any such statements.

Buyer acknowledges and agrees that it is solely responsible for compliance with all legal, regulatory and safety-related requirements concerning its products, and any use of TI components in its applications, notwithstanding any applications-related information or support that may be provided by TI. Buyer represents and agrees that it has all the necessary expertise to create and implement safeguards which anticipate dangerous consequences of failures, monitor failures and their consequences, lessen the likelihood of failures that might cause harm and take appropriate remedial actions. Buyer will fully indemnify TI and its representatives against any damages arising out of the use of any TI components in safety-critical applications.

In some cases, TI components may be promoted specifically to facilitate safety-related applications. With such components, TI's goal is to help enable customers to design and create their own end-product solutions that meet applicable functional safety standards and requirements. Nonetheless, such components are subject to these terms.

No TI components are authorized for use in FDA Class III (or similar life-critical medical equipment) unless authorized officers of the parties have executed a special agreement specifically governing such use.

Only those TI components which TI has specifically designated as military grade or "enhanced plastic" are designed and intended for use in military/aerospace applications or environments. Buyer acknowledges and agrees that any military or aerospace use of TI components which have **not** been so designated is solely at the Buyer's risk, and that Buyer is solely responsible for compliance with all legal and regulatory requirements in connection with such use.

TI has specifically designated certain components as meeting ISO/TS16949 requirements, mainly for automotive use. In any case of use of non-designated products, TI will not be responsible for any failure to meet ISO/TS16949.

### Products

Audio	<a href="http://www.ti.com/audio">www.ti.com/audio</a>
Amplifiers	<a href="http://amplifier.ti.com">amplifier.ti.com</a>
Data Converters	<a href="http://dataconverter.ti.com">dataconverter.ti.com</a>
DLP® Products	<a href="http://www.dlp.com">www.dlp.com</a>
DSP	<a href="http://dsp.ti.com">dsp.ti.com</a>
Clocks and Timers	<a href="http://www.ti.com/clocks">www.ti.com/clocks</a>
Interface	<a href="http://interface.ti.com">interface.ti.com</a>
Logic	<a href="http://logic.ti.com">logic.ti.com</a>
Power Mgmt	<a href="http://power.ti.com">power.ti.com</a>
Microcontrollers	<a href="http://microcontroller.ti.com">microcontroller.ti.com</a>
RFID	<a href="http://www.ti-rfid.com">www.ti-rfid.com</a>
OMAP Applications Processors	<a href="http://www.ti.com/omap">www.ti.com/omap</a>
Wireless Connectivity	<a href="http://www.ti.com/wirelessconnectivity">www.ti.com/wirelessconnectivity</a>

### Applications

Automotive and Transportation	<a href="http://www.ti.com/automotive">www.ti.com/automotive</a>
Communications and Telecom	<a href="http://www.ti.com/communications">www.ti.com/communications</a>
Computers and Peripherals	<a href="http://www.ti.com/computers">www.ti.com/computers</a>
Consumer Electronics	<a href="http://www.ti.com/consumer-apps">www.ti.com/consumer-apps</a>
Energy and Lighting	<a href="http://www.ti.com/energy">www.ti.com/energy</a>
Industrial	<a href="http://www.ti.com/industrial">www.ti.com/industrial</a>
Medical	<a href="http://www.ti.com/medical">www.ti.com/medical</a>
Security	<a href="http://www.ti.com/security">www.ti.com/security</a>
Space, Avionics and Defense	<a href="http://www.ti.com/space-avionics-defense">www.ti.com/space-avionics-defense</a>
Video and Imaging	<a href="http://www.ti.com/video">www.ti.com/video</a>

### TI E2E Community

[e2e.ti.com](http://e2e.ti.com)

# Mouser Electronics

Authorized Distributor

Click to View Pricing, Inventory, Delivery & Lifecycle Information:

[Texas Instruments:](#)

[SN65HVDA1050AQDRQ1](#)