



DUAL 10-BIT 40 MSPS LOW-POWER ANALOG-TO-DIGITAL CONVERTER WITH PGA

FEATURES

- Qualified for Automotive Applications
- 3.3-V Single-Supply Operation
- Dual Simultaneous Sample-and-Hold Inputs
- Differential or Single-Ended Analog Inputs
- Programmable Gain Amplifier: 0 dB to 18 dB
- Separate Serial Control Interface
- Single or Dual Parallel Bus Output
- 60-dB SNR at $f_{IN} = 10.5$ MHz
- 73-dB SFDR at $f_{IN} = 10.5$ MHz
- Low Power: 275 mW
- 300-MHz Analog Input Bandwidth
- 3.3-V TTL/CMOS-Compatible Digital I/O
- Internal or External Reference
- Adjustable Reference Input Range
- Power-Down (Standby) Mode
- TQFP-48 Package

APPLICATIONS

- Digital Communications (Baseband Sampling)
- Portable Instrumentation
- Video Processing

DESCRIPTION

The ADS5204 is a dual 10-bit, 40 MSPS analog-to-digital converter (ADC). It simultaneously converts each analog input signal into a 10-bit, binary coded digital word up to a maximum sampling rate of 40 MSPS per channel. All digital inputs and outputs are 3.3-V TTL/CMOS compatible.

An innovative dual pipeline architecture implemented in a CMOS process and the 3.3-V supply results in very low power dissipation. In order to provide maximum flexibility, both top and bottom voltage references can be set from user-supplied voltages. Alternatively, if no external references are available, the on-chip internal references can be used. Both ADCs share a common reference to improve offset and gain matching. If external reference voltage levels are available, the internal references can be powered down independently from the rest of the chip, resulting in even greater power savings.

The ADS5204 also features dual, onboard programmable gain amplifiers (PGAs) that allow a setting of 0 dB to 18 dB to adjust the gain of each set of inputs in order to match the amplitude of the incoming signal.

The ADS5204 is characterized for operation from -40°C to $+85^{\circ}\text{C}$ and is available in a TQFP-48 package.



Please be aware that an important notice concerning availability, standard warranty, and use in critical applications of Texas Instruments semiconductor products and disclaimers thereto appears at the end of this data sheet.



This integrated circuit can be damaged by ESD. Texas Instruments recommends that all integrated circuits be handled with appropriate precautions. Failure to observe proper handling and installation procedures can cause damage.

ESD damage can range from subtle performance degradation to complete device failure. Precision integrated circuits may be more susceptible to damage because very small parametric changes could cause the device not to meet its published specifications.

BLOCK DIAGRAM

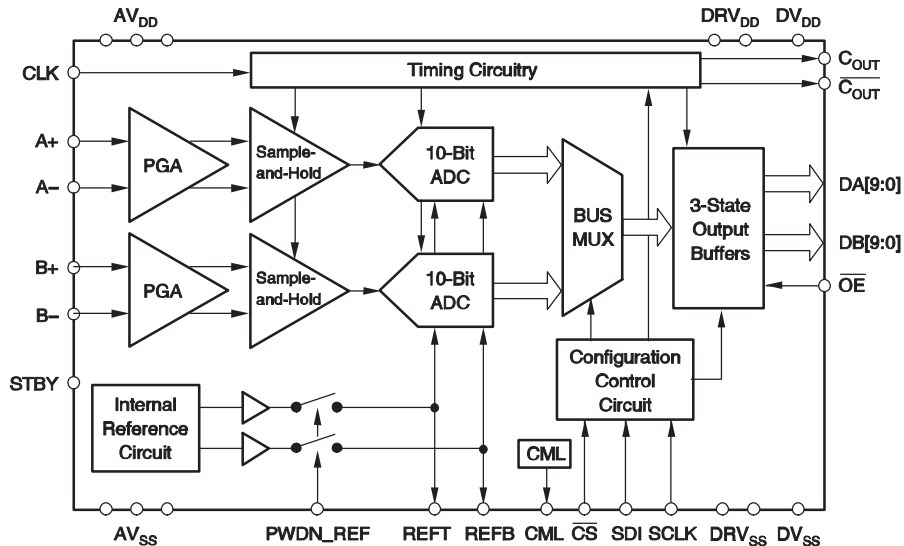

ORDERING INFORMATION†

PRODUCT	PACKAGE-LEAD	PACKAGE DESIGNATOR‡	SPECIFIED TEMPERATURE RANGE	PACKAGE MARKING	ORDERING NUMBER	TRANSPORT MEDIA, QUANTITY
ADS5204	TQFP-48	PFB	-40°C to +85°C	AZ5204Q	ADS5204IPFBRQ1	Tape and Reel, 1000

† For the most current package and ordering information, see the Package Option Addendum at the end of this document, or see the TI web site at <http://www.ti.com>.

‡ Package drawings, thermal data, and symbolization are available at <http://www.ti.com/packaging>.

ABSOLUTE MAXIMUM RATINGS

		ADS5204-Q1
AVDD to AGND, DVDD to DGND	Supply voltage	-0.5 V to 3.6 V
AVDD to DVDD, AGND to DGND		-0.5 V to 0.5 V
	Digital input voltage range to DGND	-0.5 V to DVDD + 0.5 V
Now	Analog input voltage range to AGND	-0.5 V to AVDD + 0.5 V
Now	Digital output voltage applied from Ext. Source to DGND	-0.5 V to DVDD + 0.5 V
VREF1, VREFB	Reference voltage input range to AGND	-0.5 V to AVDD + 0.5 V
TA	Operating free-air temperature range (ADS5204I)	-40°C to 85°C
TSTG	Storage temperature range	-65°C to 150°C
Now	Soldering temperature 1,6 mm (1/16 inch) from case for 10 seconds	300°C

(1) Stresses beyond those listed under "absolute maximum ratings" may cause permanent damage to the device. These are stress ratings only, and functional operation of the device at these or any other conditions beyond those indicated under "recommended operating conditions" is not implied. Exposure to absolute-maximum-rated conditions for extended periods may affect device reliability.

RECOMMENDED OPERATING CONDITIONS

 over operating free-air temperature range, T_A , unless otherwise noted⁽¹⁾

PARAMETER		CONDITIONS	MIN	NOM	MAX	UNIT
POWER SUPPLY						
AVDD	Supply voltage		0	3.3	3.6	V
DVDD						
DRVDD						
ANALOG AND REFERENCE INPUTS						
VREFT	Reference input voltage (top)	f _{CLK} = 1 MHz to 80 MHz	1.9	2	2.15	V
VREFB	Reference input voltage (bottom)	f _{CLK} = 1 MHz to 80 MHz	0.95	1	1.1	V
VREFT–VREFB	Reference voltage differential	f _{CLK} = 1 MHz to 80 MHz	0.95	1	1.1	V
RREF	Reference input resistance	f _{CLK} = 80 MHz		1650		Ω
IREF	Reference input current	f _{CLK} = 80 MHz		0.62		mA
V _{IN}	Analog input voltage, differential		–1		1	V
V _{IN}	Analog input voltage, single-ended ⁽¹⁾		CML–1		CML+1	V
C _I	Analog input capacitance			8		pF
	Clock input ⁽²⁾		0		AVDD	V
ANALOG OUTPUTS						
	CML voltage			AVDD/2		V
	CML output resistance			2.3		kΩ
DIGITAL INPUTS						
V _{IH}	High-level input voltage		2.4		DVDD	V
V _{IL}	Low-level input voltage		DGND		0.8	V
	Input capacitance			5		pF
t _C (80 MHz)	Clock period		12.5			ns
t _w (CLKH), t _w (CLKL) (80 MHz)	Pulse duration	Clock high or low	5.25			ns
t _C (40 MHz)	Clock period		25			ns
t _w (CLKH), t _w (CLKL) (40 MHz)	Pulse duration	Clock high or low	11.25			ns

⁽¹⁾ Applies only when the signal reference input connects to CML.

⁽²⁾ Clock pin is referenced to AVDD/AVSS.

ELECTRICAL CHARACTERISTICS

over recommended operating conditions with $f_{CLK} = 80\text{MHz}$ and use of internal voltage references, and PGA Gain = 0dB, unless otherwise noted.

PARAMETER		TEST CONDITIONS	MIN	TYP	MAX	UNIT	
POWER SUPPLY							
AV _{DD}	I _{DD} Operating Supply Current	AV _{DD} = DV _{DD} = DRV _{DD} = 3.3 V, C _L = 10 pF, V _{IN} = 3.5 MHz, -1 dBFS	64	72		mA	
DV _{DD}			1.7	2.2			
DRV _{DD}			18	27			
P _D	Power Dissipation	PWDN_REF = 'L'	275	345		mW	
		PWDN_REF = 'H'	240	300			
P _{D(STBY)}	Standby Power	STDBY = 'H', CLK Held HIGH or LOW	125	175		μW	
t _{PD}	Power-up time for all references from standby		550			ms	
t _{WU}	Wake-up time	External Reference	40			μs	
DIGITAL INPUTS							
I _{IH}	High-level input current on digital inputs include CLK	AV _{DD} = DV _{DD} = DRV _{DD} = 3.6 V	-1		1	μA	
I _{IL}	Low-level input current on digital inputs include CLK		-1		1	μA	
DIGITAL OUTPUTS							
V _{OH}	High-level output voltage	AV _{DD} = DV _{DD} = DRV _{DD} = 3 V at I _{OH} = 50 μA, Digital outputs forced HIGH	2.8	2.96		V	
V _{OL}	Low-level output voltage	AV _{DD} = DV _{DD} = DRV _{DD} = 3 V at I _{OL} = 50 μA, Digital outputs forced LOW		0.04	0.2	V	
C _O	Output capacitance			5		pF	
I _{OZH}	High-impedance state output current to high level	AV _{DD} = DV _{DD} = DRV _{DD} = 3.6 V	-1		1	μA	
I _{OZL}	High-impedance state output current to low level		-1		1	μA	
	Data output rise and fall time	C _{LOAD} = 10 pF, Single-bus mode		3		ns	
		C _{LOAD} = 10 pF, Dual-bus mode		5		ns	
REFERENCE OUTPUTS							
V _{REFTO}	Reference top voltage	Absolute Min/Max values valid and tested for AV _{DD} = 3.3 V	1.85	2	2.1	V	
V _{REFBO}	Reference bottom voltage		0.925	1	1.05	V	
REFT-REFB	Differential reference voltage		0.925	1.0	1.05	V	
DC ACCURACY							
INL	Integral nonlinearity, end point	Internal references ⁽¹⁾	T _A = -40°C to 85°C	-1.5	±0.4	1.5	LSB
DNL	Differential nonlinearity	Internal references ⁽²⁾	T _A = -40°C to 85°C	-0.9	±0.4	1.0	LSB
	Missing codes	No Missing Codes Assured					
	Zero error ⁽³⁾	AV _{DD} = DV _{DD} = DRV _{DD} = 3.3 V External References ⁽³⁾		0.12	±1.5	%FS	
	Full-scale error			0.28	±1.5	%FS	
	Gain error			0.24	±1.5	%FS	

(1) Integral nonlinearity refers to the deviation of each individual code from a line drawn from zero to full-scale. The point used as zero occurs 1/2 LSB before the first code transition. The full-scale point is defined as a level 1/2 LSB beyond the last code transition. The deviation is measured from the center of each particular code to the best-fit line between these two endpoints.

(2) Integral nonlinearity refers to the deviation of each individual code from a line drawn from zero to full-scale. The point used as zero occurs 1/2 LSB before the first code transition. The full-scale point is defined as a level 1/2 LSB beyond the last code transition. The deviation is measured from the center of each particular code to the best-fit line between these two endpoints.

(3) Zero error is defined as the difference in analog input voltage—between the ideal voltage and the actual voltage—that switches the ADC output from code 0 to code 1. The ideal voltage level is determined by adding the voltage corresponding to 1/2 LSB to the bottom reference level. The voltage corresponding to 1 LSB is found from the difference of top and bottom references divided by the number of ADC output levels (1024). Full-scale error is defined as the difference in analog input voltage—between the ideal voltage and the actual voltage—that switches the ADC output from code 1022 to code 1023. The ideal voltage level is determined by subtracting the voltage corresponding to 1.5 LSB from the top reference level. The voltage corresponding to 1 LSB is found from the difference of top and bottom references divided by the number of ADC output levels (1024).

DYNAMIC PERFORMANCE⁽¹⁾

$T_A = T_{MIN}$ to T_{MAX} , $AV_{DD} = DV_{DD} = DRV_{DD} = 3.3$ V, $f_{IN} = -1$ dBFS, Internal Reference, $f_{CLK} = 80$ MHz, $f_S = 40$ MSPS, Differential Input Range = 2 V_{p-p}, and PGA Gain = 0 dB, unless otherwise noted

PARAMETER		TEST CONDITIONS	MIN	TYP	MAX	UNIT
ENOB	Effective number of bits	$f_{IN} = 3.5$ MHz		9.7		Bits
		$f_{IN} = 10.5$ MHz	9.3	9.7		Bits
		$f_{IN} = 20$ MHz		9.6		Bits
THD	Total harmonic distortion	$f_{IN} = 3.5$ MHz		-71		dB
		$f_{IN} = 10.5$ MHz		-71	-63	dB
		$f_{IN} = 20$ MHz		-68		dB
SNR	Signal-to-noise ratio	$f_{IN} = 3.5$ MHz		60.5		dB
		$f_{IN} = 10.5$ MHz		60.5		dB
		$f_{IN} = 20$ MHz		60		dB
SINAD	Signal-to-noise ratio + distortion	$f_{IN} = 3.5$ MHz		60		dB
		$f_{IN} = 10.5$ MHz	57	60		dB
		$f_{IN} = 20$ MHz		60		dB
SFDR	Spurious-free dynamic range	$f_{IN} = 3.5$ MHz		75		dB
		$f_{IN} = 10.5$ MHz	66	73		dB
		$f_{IN} = 20$ MHz		70.5		dB
	Analog input bandwidth	See Note (2)		300		MHz
IMD	2-Tone intermodulation distortion	$f_1 = 9.5$ MHz, $f_2 = 9.9$ MHz		-68		dBc
	A/B channel crosstalk			-75		dBc
	A/B channel offset mismatch			0.016	1.75	% of FS
	A/B channel full-scale error mismatch			0.025	1	% of FS

(1) These specifications refer to a 25-Ω series resistor and 15-pF differential capacitor between A/B+ and A/B- inputs; any source impedance brings the bandwidth down.

(2) Analog input bandwidth is defined as the frequency at which the sampled input signal is 3 dB down on unity gain and is limited by the input switch impedance.

PGA SPECIFICATIONS

PARAMETER	MIN	TYP	MAX	UNIT
Gain Range		0 to 18		dB
Gain Step Size ⁽¹⁾		0.5826		dB
Gain Error ⁽²⁾	-0.15	±0.025	0.15	dB
Control Bits Per Channel			5	Bits

(1) See Table 2, PGA Gain Code. Ideal step size: 18.0618 dB / 31 = 0.5826 dB

(2) Deviation from ideal. See Table 2, all gain settings.

PIN CONFIGURATION

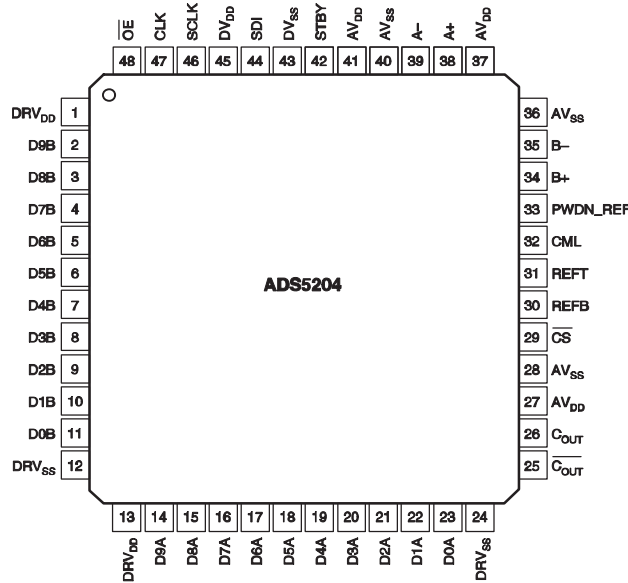

Terminal Functions

TERMINAL NAME	NO.	I/O	DESCRIPTION
DRV _{DD}	1,13	I	Supply Voltage for Output Drivers
DRV _{SS}	12, 24	I	Digital Ground for Output Drivers
DA 9..0	14-23	O	Data Outputs for Bus A. D9 is MSB. This is the primary bus. Data from both input channels can be output on this bus or data from channel A only. The data outputs are in 3-state during power-down (see the <i>Register Configuration</i> table).
DB 9..0	2-11	O	Data Outputs for Bus B. D9 is MSB. This is the second bus. Data is output from the B channel when dual bus output mode is selected. The data outputs are in 3-state during power-down and single-bus modes (see the <i>Timing Options</i> table).
\overline{OE}	48	I	Output Enable. A low on this terminal will enable the data output bus, C _{OUT} and $\overline{C_{OUT}}$.
C _{OUT}	26	O	Latch Clock for the Data Outputs. C _{OUT} is in 3-state during power down.
$\overline{C_{OUT}}$	25	O	Inverted Latch Clock control for the Data Outputs. $\overline{C_{OUT}}$ is in 3-state during power down.
SDI	44	I	Serial Data I/O
DV _{SS}	43	I	Digital Ground
CLK	47	I	Clock Input. The input is sampled on each rising edge of CLK when using a 40-MHz input and alternate rising edges when using an 80-MHz input. The clock pin is referenced to AV _{DD} and AV _{SS} to reduce noise coupling from digital logic.
DV _{DD}	45	I	Digital Supply Voltage
AV _{DD}	27,37,41	I	Analog Supply Voltage
\overline{CS}	29	I	Serial Data Registers Chip Select
AV _{SS}	28,36,40	I	Analog Ground
B-	35	I	Negative Input for the Analog B Channel
B+	34	I	Positive Input for the Analog B Channel
REFT	31	I/O	Reference Voltage Top. The voltage at this terminal defines the top reference voltage for the ADC. Sufficient filtering should be applied to this input: the use of 0.1- μ F capacitor between REFT and AV _{SS} is highly recommended. Additionally a 0.1- μ F capacitor should be connected between REFT and REFB.
REFB	30	I/O	Reference Voltage Bottom. The voltage at this terminal defines the bottom reference voltage for the ADC. Sufficient filtering should be applied to this input: the use of 0.1- μ F capacitor between REFB and AV _{SS} is recommended. Additionally, a 0.1- μ F capacitor should be connected between REFT and REFB.
CML	32	O	Common-Mode Level. This voltage is equal to (AV _{DD} – AV _{SS})/2. An external capacitor of 0.1 μ F should be connected between this terminal and AV _{SS} when CML is used as a bias voltage. No capacitor is required if CML is not used.
PDOWN_REF	33	I	Power-Down for Internal Reference Voltages. A HIGH on this terminal disables the internal reference circuit.
STBY	42	I	Standby Input. A high on this terminal powers down the device.
A-	39	I	Negative Input for the Analog A Channel
A+	38	I	Positive Input for Analog A Channel
SCLK	46	I	Serial Data Clock. Maximum clock rate is 20 MHz.

TIMING REQUIREMENTS

PARAMETER		TEST CONDITIONS	MIN	TYP	MAX	UNIT
f _{CLK}	Input clock rate		1		80	MHz
	Conversion rate		1		40	MSPS
	Clock duty cycle (40MHz)		45	50	55	%
	Clock duty cycle (80MHz)		42	50	58	%
t _{d(o)}	Output delay time	C _L = 10 pF		9	14	ns
t _{s(m)}	Mux setup time		9	10.4		ns
t _{h(m)}	Mux hold time	C _L = 10 pF	1.7	2.1		ns
t _{s(o)}	Output setup time	C _L = 10 pF	9	10.4		ns
t _{d(pipe)}	Pipeline delay (latency, channels A and B)	MODE = 0, SELB = 0		8		CLK Cycles
t _{d(pipe)}	Pipeline delay (latency, channels A and B)	MODE = 1, SELB = 0		4		CLK Cycles
t _{d(pipe)}	Pipeline delay (latency, channel A)	MODE = 0, SELB = 1		8		CLK Cycles
t _{d(pipe)}	Pipeline delay (latency, channel B)	MODE = 0, SELB = 1		9		CLK Cycles
t _{d(pipe)}	Pipeline delay (latency, channel A)	MODE = 1, SELB = 1		8		CLK Cycles
t _{d(pipe)}	Pipeline delay (latency, channel B)	MODE = 1, SELB = 1		9		CLK Cycles
t _{h(o)}	Output hold time	C _L = 10 pF	1.5	2.2		ns
t _{d(a)}	Aperture delay time			3		ns
t _{J(a)}	Aperture jitter			1.5		ps, rms
t _{dis}	Disable time, \overline{OE} rising to Hi-Z			5	8	ns
t _{en}	Enable Time, \overline{OE} falling to valid data			5	8	ns

(1) All internal operations are performed at a 40-MHz clock rate.

SERIAL INTERFACE TIMING

PARAMETER		MIN	TYP	MAX	UNIT
f _{SCLK}	Maximum Clock Rate	20			MHz
t _{WH}	SCLK Pulse Width high	25			ns
t _{WH}	SCLK Pulse Width low	25			ns
t _{SU(CS_CK)}	Setup Time, \overline{CS} low Before First Negative SCLK Edge	5			ns
t _{WH(CS)}	\overline{CS} HIGH Width	10			ns
t _{SU(C16_CK)}	Setup Time, 16th Negative SCLK Edge before \overline{CS} Rising Edge	5			ns
t _{SU(D)}	Setup Time, Data Ready Before SCLK Falling Edge	5			ns
t _{SU(H)}	Hold Time, Data Held Valid After SCLK Falling Edge	5			ns

TIMING OPTIONS

OPERATING MODE	MODE	SELB	TIMING DIAGRAM FIGURE
80-MHz Input Clock, Dual-Bus Output, C _{OUT} = 40 MHz	0	0	1
40-MHz Input Clock, Dual-Bus Output, C _{OUT} = 40 MHz	1	0	2
80-MHz Input Clock, Single-Bus Output, C _{OUT} = 40 MHz	0	1	3
80-MHz Input Clock, Single-Bus Output, C _{OUT} = 80 MHz	1	1	4

TIMING DIAGRAMS

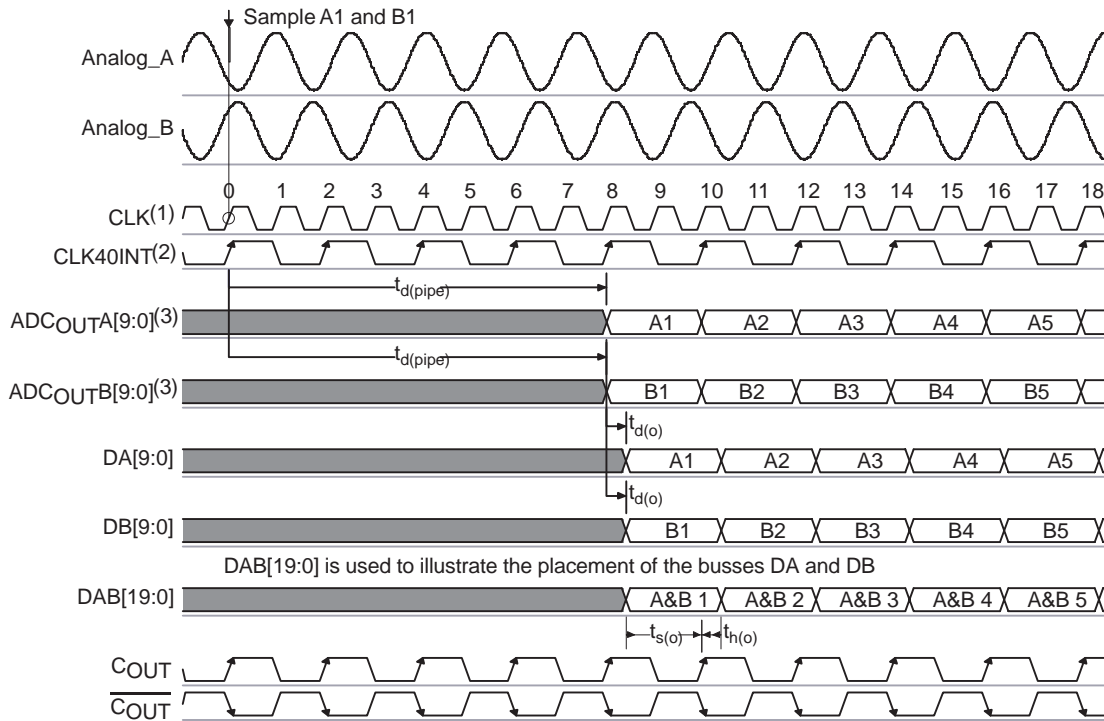

- (1) In this option CLK = 80 MHz.
- (2) CLK40INT refers to 40-MHz Internal Clock, per channel.
- (3) Internal signal only.

Figure 1. Dual Bus Output—Option 1

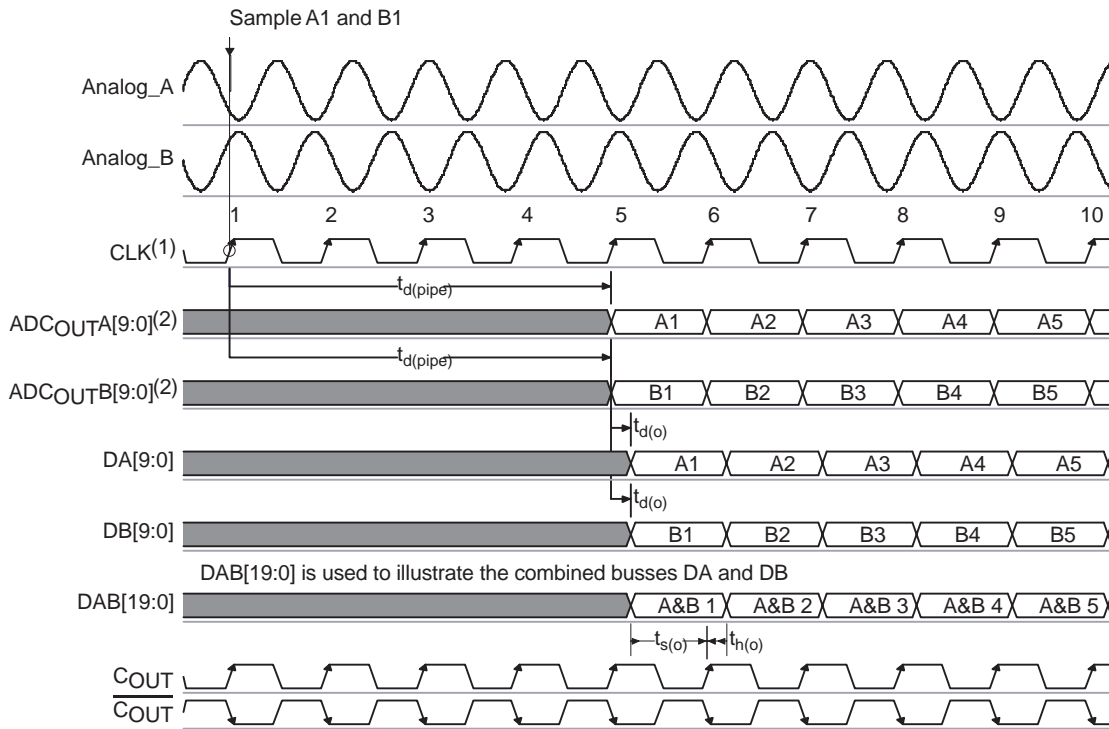

- (1) In this option CLK = 40 MHz, per channel.
- (2) Internal signal only.

Figure 2. Dual Bus Output—Option 2

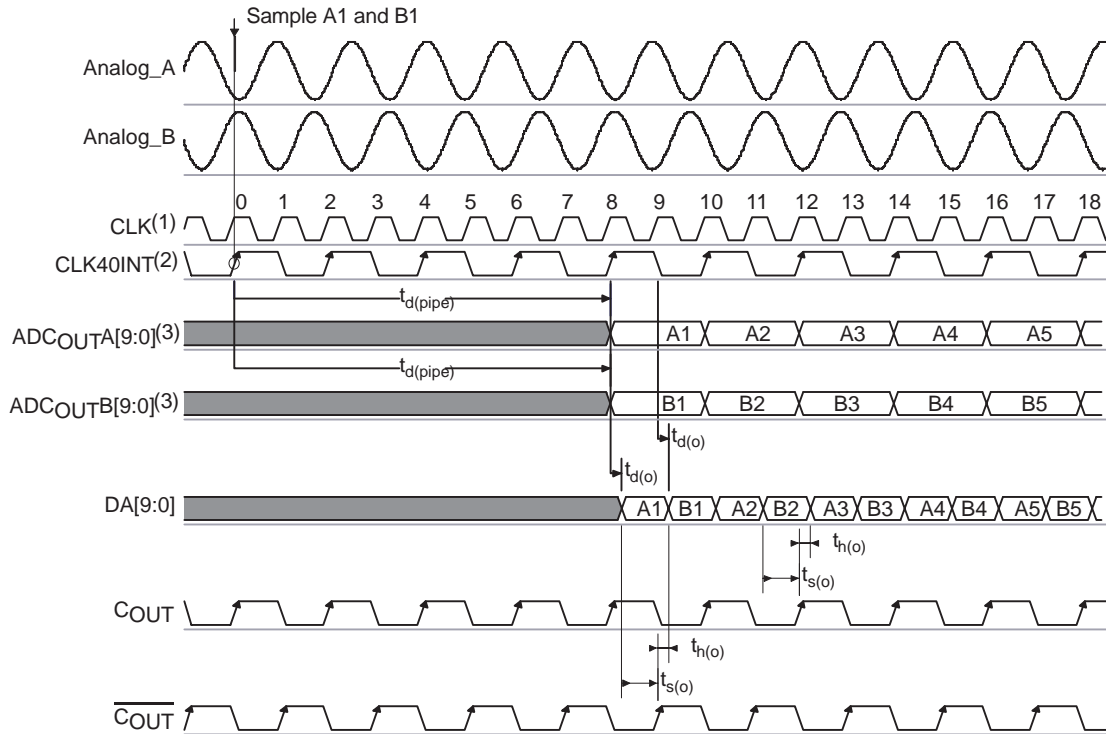

- (1) In this option CLK = 80 MHz.
- (2) CLK40INT refers to 40-MHz internal Clock, per channel.
- (3) Internal signal only.

Figure 3. Single Bus Output—Option 1

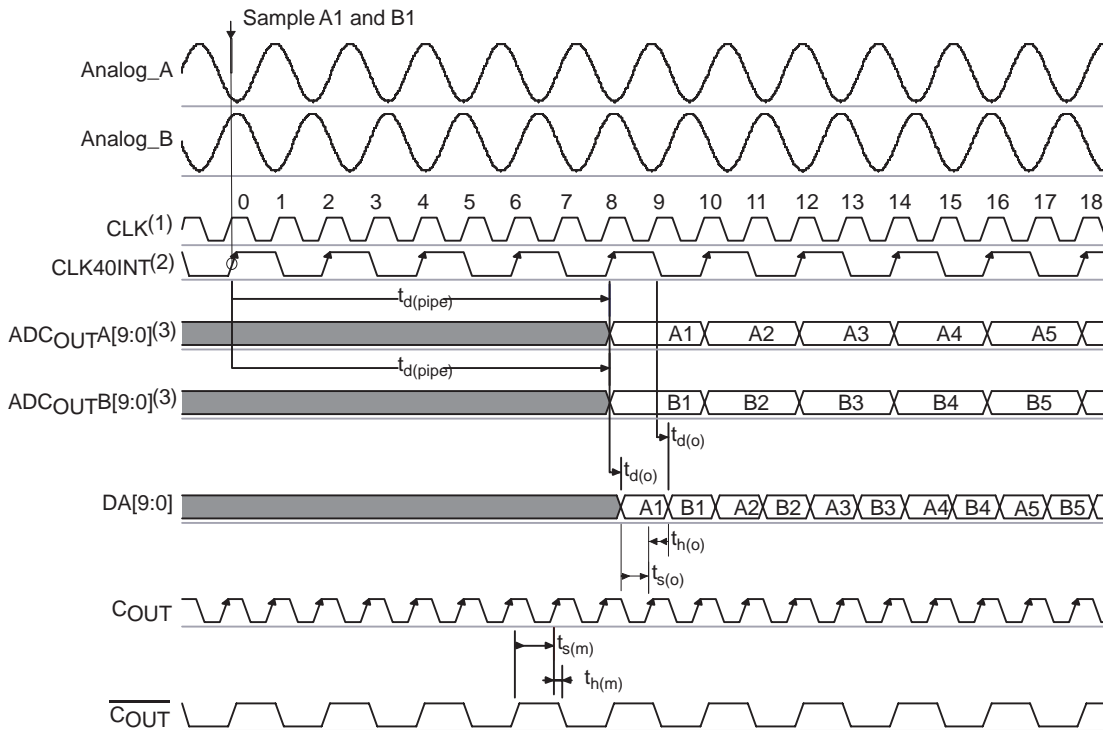

- (1) In this option CLK = 80 MHz.
- (2) CLK40INT refers to 40-MHz internal Clock, per channel.
- (3) Internal signal only.

Figure 4. Single Bus Output—Option 2

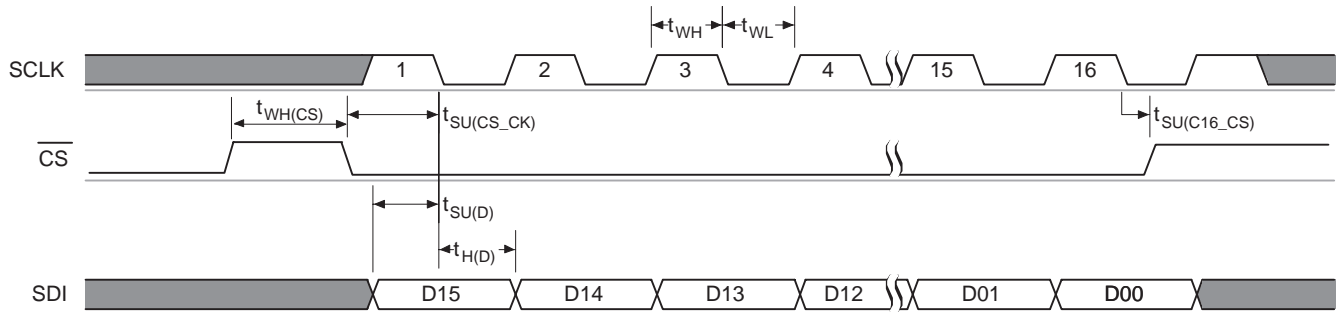

Figure 5. Serial Data Write

Table 1. Register Configuration

15	14	13	12	11	10	9	8	7	6	5	4	3	2	1	0
0	0	Reserved	TWOS	MODE	SELB	PGA4 B	PGA3 B	PGA2 B	PGA1 B	PGA0 B	PGA4 A	PGA3 A	PGA2 A	PGA1 A	PGA0 A

Always write 0

Default (power up) condition for this register is all bits = 0. The user register is updated on either the first rising edge of SCLK after the 16th falling edge or \overline{CS} rising, whichever comes first. Raising \overline{CS} before 16 falling SCLK edges have been seen is an incomplete write error and no register update occurs. The PGA gain settings are resynchronized to the internal data conversion clock to avoid data glitches caused by changing gain settings while sampling the inputs.

PGA gain control data is applied to the PGAs on the second falling edge of the ADC sample clock (CLK40INT) after a successful register write. This resynchronization ensures that no analog glitch occurs even when SCLK is asynchronous to CLK.

Note that only the PGA data is resynchronized. The TWOS, MODE, and SELB register bits take effect immediately after a successful register write.

OUTPUT DATA FORMAT

The output data format can either be in Binary Two's Complement output mode or in unsigned binary mode, which affects both A and B channels.

TWOS – Binary Two's Complement Mode:

0 – Unsigned Binary

1 – Binary Two's Complement Output.

Table 2. PGA DB[0:4], 5-bit PGA gain code for channel A or B

GAIN (dB)	PGx4	PGx3	PGx2	PGx1	PGx0
0	0	0	0	0	0
0.5606	0	0	0	0	1
1.1599	0	0	0	1	0
1.6643	0	0	0	1	1
2.3806	0	0	1	0	0
2.8703	0	0	1	0	1
3.5218	0	0	1	1	0
4.0824	0	0	1	1	1
4.6817	0	1	0	0	0
5.1630	0	1	0	0	1
5.8451	0	1	0	1	0
6.3903	0	1	0	1	1
6.9807	0	1	1	0	0
7.6040	0	1	1	0	1
8.0497	0	1	1	1	0
8.7712	0	1	1	1	1
9.2831	1	0	0	0	0
9.8272	1	0	0	0	1
10.4078	1	0	0	1	0
11.0301	1	0	0	1	1
11.7005	1	0	1	0	0
12.0412	1	0	1	0	1
12.7970	1	0	1	1	0
13.2208	1	0	1	1	1
14.0944	1	1	0	0	0
14.5400	1	1	0	0	1
15.0666	1	1	0	1	0
15.5630	1	1	0	1	1
16.1623	1	1	1	0	0
16.7229	1	1	1	0	1
17.4181	1	1	1	1	0
18.0618	1	1	1	1	1

TYPICAL CHARACTERISTICS

At $T_A = 25^\circ\text{C}$, $AV_{DD} = DV_{DD} = DRV_{DD} = 3.3\text{ V}$, $f_{IN} = -0.5\text{ dBFS}$, Internal Reference, $f_{CLK} = 80\text{ MHz}$, $f_S = 40\text{ MSPS}$, Differential Input Range = 2 V_{p-p} , $25\text{-}\Omega$ series resistor, and 15-pF differential capacitor at A/B+ and A/B- inputs, unless otherwise noted.

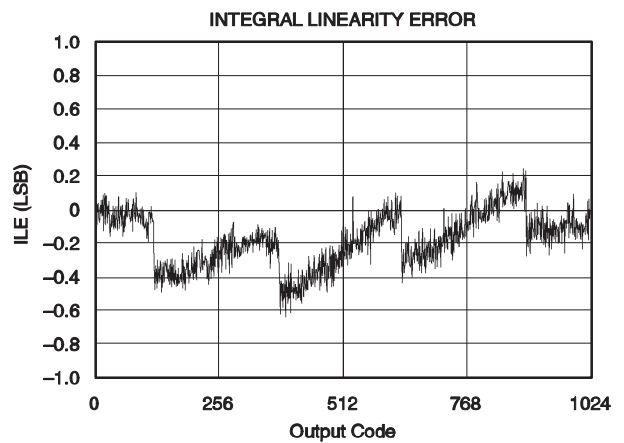
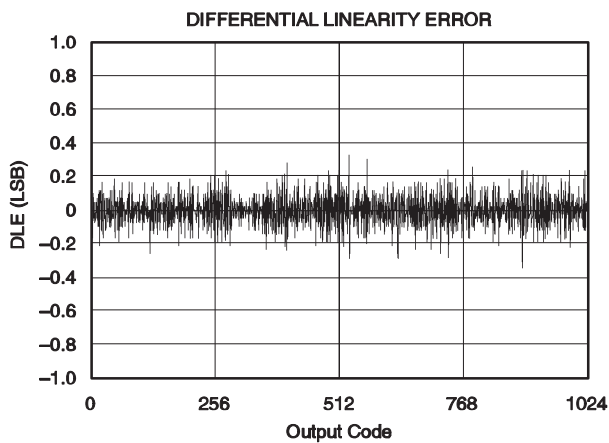
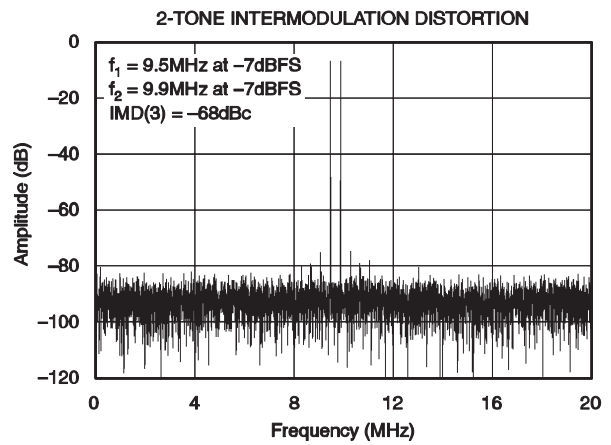
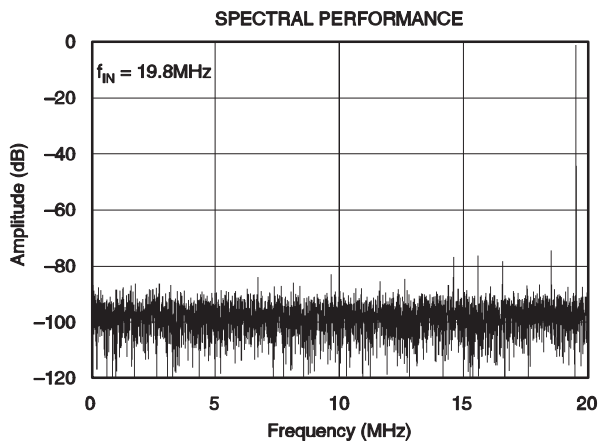
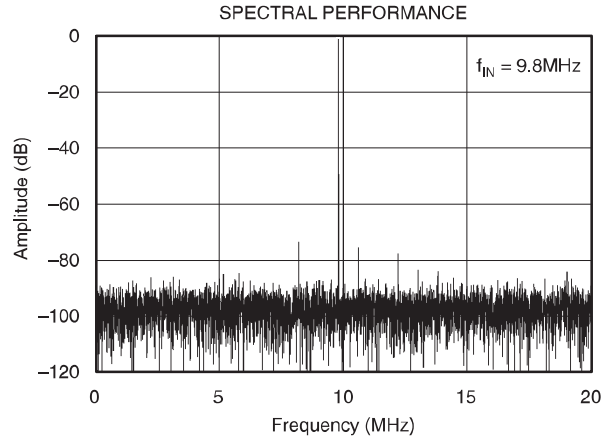
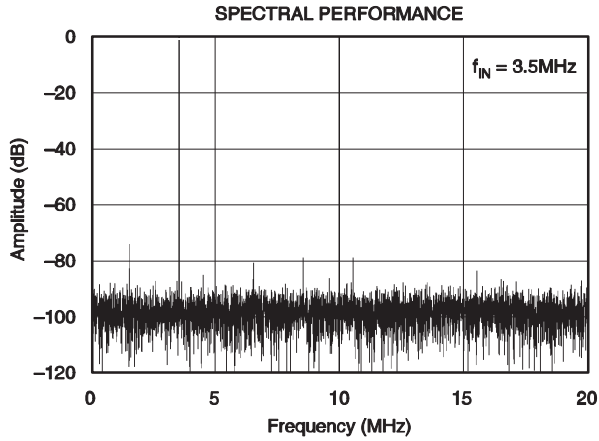

TYPICAL CHARACTERISTICS (Continued)

At $T_A = 25^\circ\text{C}$, $AV_{DD} = DV_{DD} = DRV_{DD} = 3.3\text{ V}$, $f_{IN} = -0.5\text{ dBFS}$, Internal Reference, $f_{CLK} = 80\text{ MHz}$, $f_S = 40\text{ MSPS}$, Differential Input Range = 2 V_{p-p} , $25\text{-}\Omega$ series resistor, and 15-pF differential capacitor at A/B+ and A/B- inputs, unless otherwise noted.

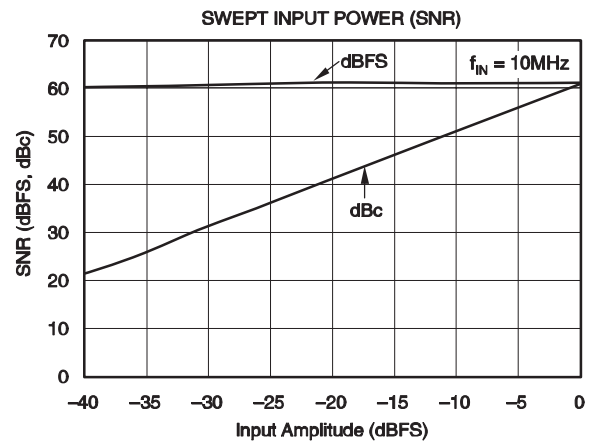
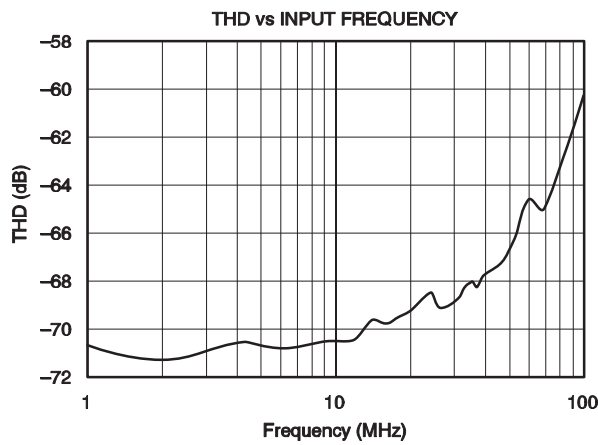
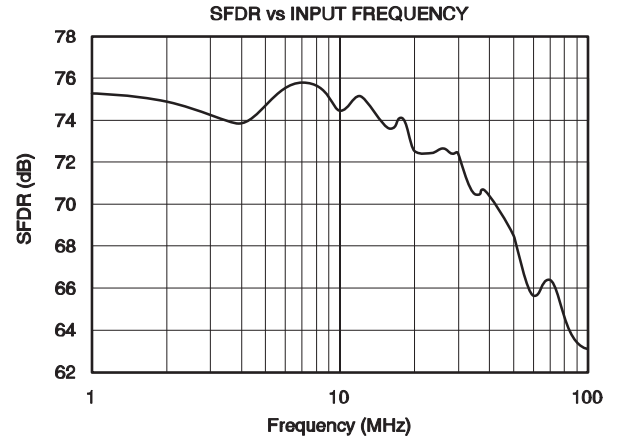
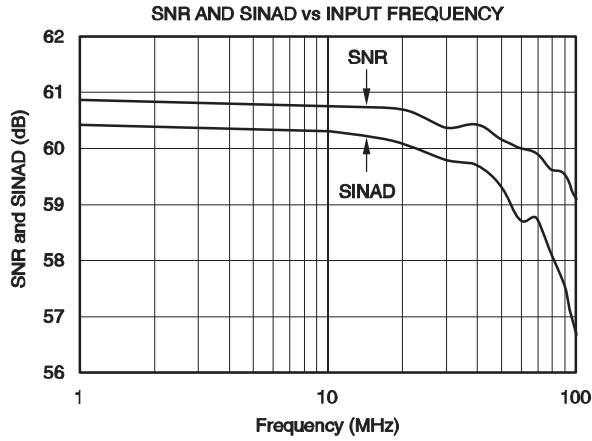

PRINCIPLE OF OPERATION

The ADS5204 implements a dual high-speed 10-bit, 40MSPS converter in a cost-effective CMOS process. The differential inputs on each channel are sampled simultaneously. Signal inputs are differential and the clock signal is single-ended. The clock signal is either 80 MHz or 40 MHz, depending on the device configuration set by the user. Powered from 3.3 V, the dual-pipeline design architecture ensures low-power operation and 10-bit resolution. The digital inputs are 3.3-V TTL/CMOS compatible. Internal voltage references are included for both bottom and top voltages. Alternatively, the user may apply externally generated reference voltages. In doing so, the input range can be modified to suit the application.

The ADC is a 5-stage pipelined ADC with four stages of fully-differential switched capacitor sub-ADC/MDAC pairs and a single sub-ADC in stage five. All stages deliver two bits of the final conversion result. A digital error correction is used to compensate for modest comparator offsets in the sub-ADCs.

SAMPLE-AND-HOLD AMPLIFIER

Figure 6 shows the internal SHA/SHPGA architecture. The circuit is balanced and fully differential for good supply noise rejection. The sampling circuit has been kept as simple as possible to obtain good performance for high-frequency input signals.

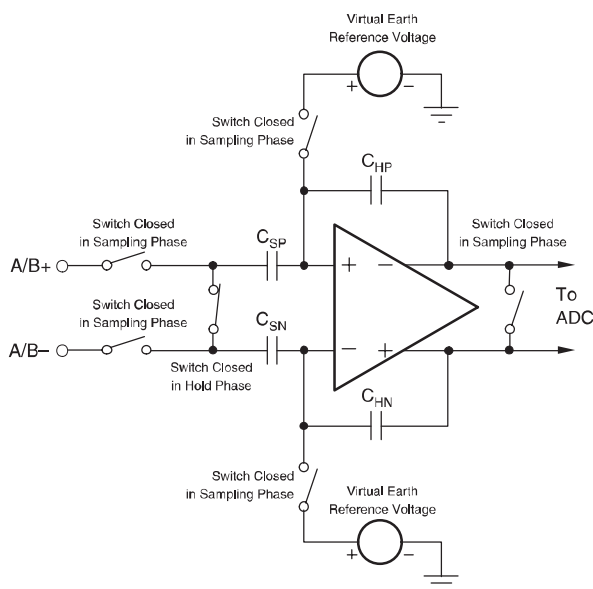

Figure 6. SHA/SHPGA Architecture

The analog input signal is sampled on capacitors C_{SP} and C_{SN} while the internal device clock is low. The sampled voltage is transferred to capacitors C_{HP} and C_{HN} and held on these while the internal device clock is high. The SHA can sample both single-ended and differential input signals.

The load presented to the AIN pin consists of the switched input sampling capacitor C_S (approximately 2 pF) and its various stray capacitances. A simplified equivalent circuit for the switched capacitor input is shown in Figure 7. The switched capacitor circuit is modeled as a resistor R_{IN} . f_{CLK} is the clock frequency, which is 40 MHz at full speed, and C_S is the sampling capacitor. The use of 25- Ω series resistors and a differential 15-pF capacitor at the A/B+ and A/B- inputs is recommended to reduce noise.

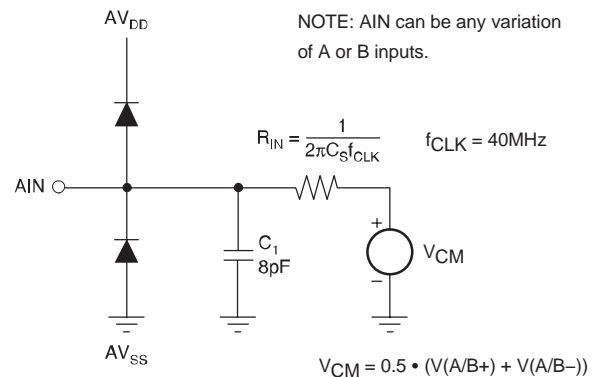

Figure 7. Equivalent Circuit for the Switched Capacitor Input

ANALOG INPUT, DIFFERENTIAL CONNECTION

The analog input of the ADS5204 is a differential architecture that can be configured in various ways depending on the signal source and the required level of performance. A fully differential connection will deliver the best performance from the converter. The analog inputs must not go below AV_{SS} or above AV_{DD} . The inputs can be biased with any common-mode voltage provided that the minimum and maximum input voltages stay within the range AV_{SS} to AV_{DD} . It is recommended to bias the inputs with a common-mode voltage around $AV_{DD}/2$. This can be accomplished easily with the output voltage source CML, which is equal to $AV_{DD}/2$. CML is made available to the user to help simplify circuit design. This output voltage source is not designed to be a reference or to be loaded but makes an excellent dc bias source and stays well within the analog input common-mode voltage range over temperature.

Table 3 lists the digital outputs for the corresponding analog input voltages.

Table 3. Output Format for Differential Configuration

DIFFERENTIAL INPUT	
$V_{IN} = (A/B+) - (A/B-)$, REFT – REFB = 1 V, PGA = 0 dB	
ANALOG INPUT VOLTAGE	DIGITAL OUTPUT CODE
$V_{IN} = +1$ V	3FF _H
$V_{IN} = 0$	200 _H
$V_{IN} = -1$ V	000 _H

DC-COUPLED DIFFERENTIAL ANALOG INPUT CIRCUIT

Driving the analog input differentially can be achieved in various ways. Figure 8 gives an example where a single-ended signal is converted into a differential signal by using a fully differential amplifier such as the THS4141. The input voltage applied to V_{OCM} of the THS4141 shifts the output signal into the desired common-mode level. V_{OCM} can be connected to CML of the ADS5204, the common-mode level is shifted to $AV_{DD}/2$.

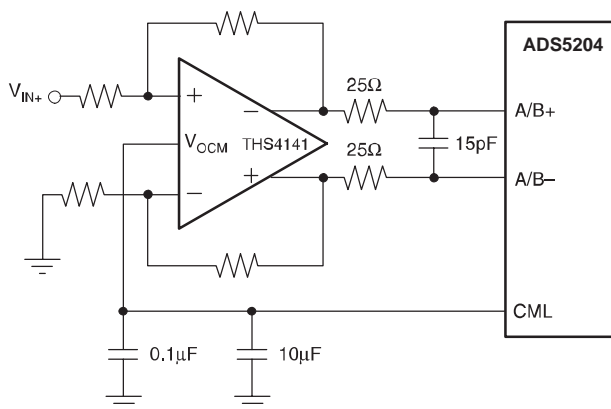

Figure 8. Single-Ended to Differential Conversion Using the THS4141

AC-COUPLED DIFFERENTIAL ANALOG INPUT CIRCUIT

Driving the analog input differentially can be achieved by using a transformer coupling, as illustrated in NO TAG. The center tap of the transformer is connected to the voltage source CML, which sets the common-mode voltage to $AV_{DD}/2$. No buffer is required at the output of CML since the circuit is balanced and no current is drawn from CML.

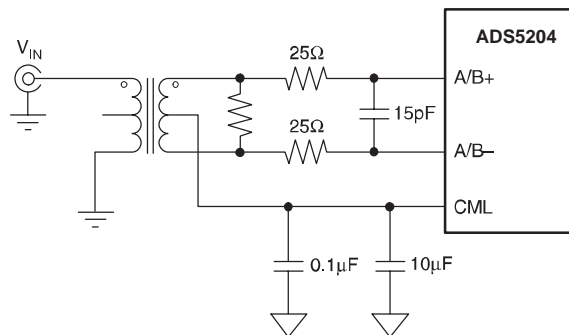

Figure 9. AC-Coupled Differential Input with Transformer

ANALOG INPUT, SINGLE-ENDED CONFIGURATION

For a single-ended configuration, the input signal is applied to only one of the two inputs. The signal applied to the analog input must not go below AV_{SS} or above AV_{DD} . The inputs can be biased with any common-mode voltage provided that the minimum and maximum input voltage stays within the range AV_{SS} to AV_{DD} . It is recommended to bias the inputs with a common-mode voltage around $AV_{DD}/2$. This can be accomplished easily with the output voltage source CML, which is equal to $AV_{DD}/2$. An example for this is shown in Figure 10.

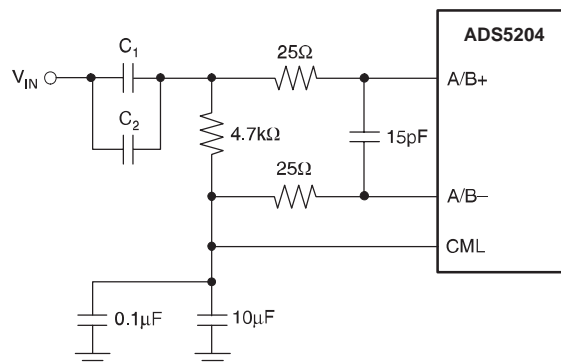

Figure 10. AC-Coupled, Single-Ended Configuration

The signal amplitude to achieve full-scale is 2 V_{p-p}. The signal, which is applied at A/B+ is centered at the bias voltage. The input A/B- is also centered at the bias voltage. The CML output is connected via a 4.7-kΩ resistor to bias the input signal. There is a direct dc-coupling from CML to A/B- while this input is ac-decoupled through the 10-μF and 0.1-μF capacitors. The decoupling minimizes the coupling of A/B+ into the A/B- path.

Table 4 lists the digital outputs for the corresponding analog input voltages.

Table 4. Output Format for Single-Ended Configuration

SINGLE-ENDED INPUT, REFT – REFB = 1V, PGA = 0dB	
ANALOG INPUT VOLTAGE	DIGITAL OUTPUT CODE
$V(A/B+) = V_{CML} + 1V$	3FFH
$V(A/B+) = V_{CML}$	200H
$V(A/B+) = V_{CML} - 1V$	000H

REFERENCE TERMINALS

The ADS5204’s input range is determined by the voltages on its REFB and REFT pins. The ADS5204 has an internal voltage reference generator that sets the ADC reference voltages REFB = 1 V and REFT = 2 V. The internal ADC references must be decoupled to the PCB AVSS plane. The recommended decoupling scheme is shown in Figure 11. The common-mode reference voltages should be 1.5 V for best ADC performance.

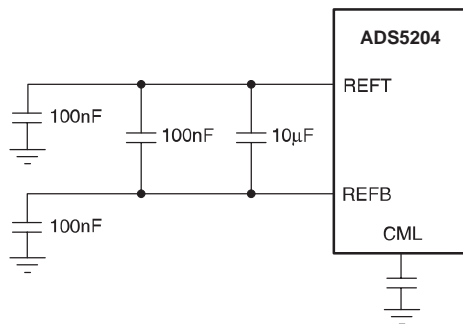

Figure 11. Recommended External Decoupling for the Internal ADC Reference

External ADC references can also be chosen. The ADS5204 internal references must be disabled by tying PWDN_REF high before applying the external reference sources to the REFT and REFB pins. The common-mode reference voltages should be 1.5 V for best ADC performance.

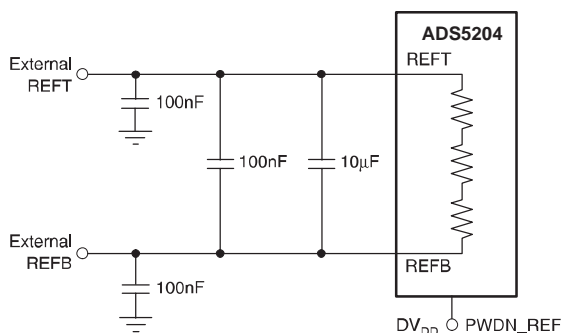

Figure 12. External ADC Reference Configuration

DIGITAL INPUTS

Digital inputs are CLK, SCLK, SDI, \overline{CS} , STDBY, PWDN_REF, and \overline{OE} . These inputs don’t have a pulldown resistor to ground, therefore, they should not be left floating.

The CLK signal at high frequencies should be considered as an ‘analog’ input. CLK should be referenced to AVDD and AVSS to reduce noise coupling from the digital logic. Overshoot/undershoot should be minimized by proper termination of the signal close to the ADS5204. An important cause of performance degradation for a high-speed ADC is clock jitter. Clock jitter causes uncertainty in the sampling instant of the ADC, in addition to the inherent uncertainty on the sampling instant caused by the part itself, as specified by its aperture jitter. There is a theoretical relationship between the frequency (f) and resolution (2^N) of a signal that needs to be sampled on one hand, and on the other hand the maximum amount of aperture error dt_{max} that is tolerable. It is given by the following relation:

$$dt_{max} = 1/[\pi f 2^{(N+1)}]$$

As an example, for a 10-bit converter with a 20MHz input, the jitter needs to be kept less than 7.8ps in order not to have changes in the LSB of the ADC output due to the total aperture error.

DIGITAL OUTPUTS

The output of ADS5204 is an unsigned binary or Binary Two’s Complement code. Capacitive loading on the output should be kept as low as possible (a maximum loading of 10 pF is recommended) to ensure best performance. Higher output loading causes higher dynamic output currents and can, therefore, increase noise coupling into the part’s analog front end. To drive higher loads, the use of an output buffer is recommended.

When clocking output data from ADS5204, it is important to observe its timing relation to COUT. See the Timing section for detailed information on the pipeline latency in the different modes.

For safest system timing, COUT and \overline{COUT} should be used to latch the output data (see Figure 1 through Figure 4). In Figure 4, \overline{COUT} can be used by the receiving device to identify whether the data presently on the bus is from channel A or B.

LAYOUT, DECOUPLING, AND GROUNDING RULES

Proper grounding and layout of the PCB on which the ADS5204 is populated is essential to achieve the stated performance. It is advised to use separate analog and digital ground planes that are spliced underneath the IC. The ADS5204 has digital and analog pins on opposite sides of the package to make this easier. Since there is no connection internally between analog and digital grounds, they have to be joined on the PCB. It is advised to do this at one point in close proximity to the ADS5204.

As for power supplies, separate analog and digital supply pins are provided on the part (AV_{DD}/DV_{DD}). The supply to the digital output drivers is kept separate as well (DRV_{DD}). Lowering the voltage on this supply to 3 V instead of the nominal 3.3 V improves performance because of the lower switching noise caused by the output buffers.

Due to the high sampling rate and switched-capacitor architecture, the ADS5204 generates transients on the supply and reference lines. Proper decoupling of these lines is, therefore, essential.

SERIAL INTERFACE

A falling edge on \overline{CS} enables the serial interface, allowing the 16-bit control register data to be shifted (MSB first) on subsequent falling edges of SCLK. The data is loaded into the control register on the first rising edge of SCLK after its 16th falling edge or \overline{CS} rising, whichever occurs first. \overline{CS} rising before 16 falling SCLK edges have been counted is an error and the control register will not be updated.

The maximum update rate is:

$$f_{UPDATE\ MAX} = \frac{f_{SCLK}}{16} = \frac{20\text{MHz}}{16} = 1.25\text{MHz}$$

NOTES

1. Integral Nonlinearity (INL)—Integral nonlinearity refers to the deviation of each individual code from a line drawn from zero to full-scale. The point used as zero occurs 1/2 LSB before the first code transition. The full-scale point is defined as a level 1/2 LSB beyond the last code transition. The deviation is measured from the center of each particular code to the true straight line between these two endpoints.

2. Differential Nonlinearity (DNL)—An ideal ADC exhibits code transitions that are exactly 1 LSB apart. DNL is the deviation from this ideal value. Therefore, this measure indicates how uniform the transfer function step sizes are. The ideal step size is defined here as the step size for the device under test [i.e. (last transition level –

first transition level)/($2^n - 2$)]. Using this definition for DNL separates the effects of gain and offset error. A minimum DNL better than -1LSB ensures no missing codes.

3. Zero and Full-Scale Error—Zero error is defined as the difference in analog input voltage—between the ideal voltage and the actual voltage—that switches the ADC output from code 0 to code 1. The ideal voltage level is determined by adding the voltage corresponding to 1/5 LSB to the bottom reference level. The voltage corresponding to 1 LSB is found from the difference of top and bottom references divided by the number of ADC output levels (1024).

Full-scale error is defined as the difference in analog input voltage—between the ideal voltage and the actual voltage—that switches the ADC output from code 1022 to code 1023. The ideal voltage level is determined by subtracting the voltage corresponding to 1.5LSB from the top reference level. The voltage corresponding to 1 LSB is found from the difference of top and bottom references divided by the number of ADC output levels (1024).

4. Analog Input Bandwidth—The analog input bandwidth is defined as the max. frequency of a 1-dBFS input sine that can be applied to the device for which an extra 3-dB attenuation is observed in the reconstructed output signal.

5. Output Timing—Output timing $t_{d(o)}$ is measured from the 1.5-V level of the CLK input falling edge to the 10%/90% level of the digital output. The digital output load is not higher than 10 pF. Output hold time $t_{h(o)}$ is measured from the 1.5-V level of the C_{OUT} input rising edge to the 10%/90% level of the digital output. The digital output is load is not less than 2 pF. Aperture delay $t_{d(A)}$ is measured from the 1.5-V level of the CLK input to the actual sampling instant.

The \overline{OE} signal is asynchronous. \overline{OE} timing t_{dis} is measured from the $V_{IH(MIN)}$ level of \overline{OE} to the high-impedance state of the output data. The digital output load is not higher than 10 pF. \overline{OE} timing t_{en} is measured from the $V_{IL(MAX)}$ level of \overline{OE} to the instant when the output data reaches $V_{OH(min)}$ or $V_{OL(max)}$ output levels. The digital output load is not higher than 10 pF.

6. Pipeline Delay (latency)—The number of clock cycles between conversion initiation on an input sample and the corresponding output data being made available from the ADC pipeline. Once the data pipeline is full, new valid output data is provided on every clock cycle. The first valid data is available on the output pins after the latency time plus the output delay time $t_{d(o)}$ through the digital output buffers. Note that a minimum $t_{d(o)}$ is not assured because data can transition before or after a CLK edge. It is possible to use CLK for latching data, but at the risk of the prop delay varying over temperature, causing data to transition one CLK cycle

earlier or later. The recommended method is to use the latch signals $\overline{C_{OUT}}$ and $\overline{C_{OUT}}$ which are designed to provide reliable setup and hold times with respect to the data out.

7. Wake-Up Time—Wake-up time is from the power-down state to accurate ADC samples being taken and is specified for external reference sources applied to the device and an 80-MHz clock applied at the time of release of STDBY. Cells that need to power up are the bandgap, bias generator, SHAs, and ADCs.

8. Power-Up Time—Power-up time is from the power-down state to accurate ADC samples being taken with an 80-MHz clock applied at the time of release of STDBY. Cells that need to power up are the bandgap, internal reference circuit, bias generator, SHAs, and ADCs.

PACKAGING INFORMATION

Orderable Device	Status ⁽¹⁾	Package Type	Package Drawing	Pins	Package Qty	Eco Plan ⁽²⁾	Lead/ Ball Finish	MSL Peak Temp ⁽³⁾	Samples (Requires Login)
ADS5204IPFBRG4Q1	ACTIVE	TQFP	PFB	48	1000	Green (RoHS & no Sb/Br)	CU NIPDAU	Level-3-260C-168 HR	
ADS5204IPFBRQ1	ACTIVE	TQFP	PFB	48	1000	Green (RoHS & no Sb/Br)	CU NIPDAU	Level-3-260C-168 HR	

⁽¹⁾ The marketing status values are defined as follows:

ACTIVE: Product device recommended for new designs.

LIFEBUY: TI has announced that the device will be discontinued, and a lifetime-buy period is in effect.

NRND: Not recommended for new designs. Device is in production to support existing customers, but TI does not recommend using this part in a new design.

PREVIEW: Device has been announced but is not in production. Samples may or may not be available.

OBsolete: TI has discontinued the production of the device.

⁽²⁾ Eco Plan - The planned eco-friendly classification: Pb-Free (RoHS), Pb-Free (RoHS Exempt), or Green (RoHS & no Sb/Br) - please check <http://www.ti.com/productcontent> for the latest availability information and additional product content details.

TBD: The Pb-Free/Green conversion plan has not been defined.

Pb-Free (RoHS): TI's terms "Lead-Free" or "Pb-Free" mean semiconductor products that are compatible with the current RoHS requirements for all 6 substances, including the requirement that lead not exceed 0.1% by weight in homogeneous materials. Where designed to be soldered at high temperatures, TI Pb-Free products are suitable for use in specified lead-free processes.

Pb-Free (RoHS Exempt): This component has a RoHS exemption for either 1) lead-based flip-chip solder bumps used between the die and package, or 2) lead-based die adhesive used between the die and leadframe. The component is otherwise considered Pb-Free (RoHS compatible) as defined above.

Green (RoHS & no Sb/Br): TI defines "Green" to mean Pb-Free (RoHS compatible), and free of Bromine (Br) and Antimony (Sb) based flame retardants (Br or Sb do not exceed 0.1% by weight in homogeneous material)

⁽³⁾ MSL, Peak Temp. -- The Moisture Sensitivity Level rating according to the JEDEC industry standard classifications, and peak solder temperature.

Important Information and Disclaimer: The information provided on this page represents TI's knowledge and belief as of the date that it is provided. TI bases its knowledge and belief on information provided by third parties, and makes no representation or warranty as to the accuracy of such information. Efforts are underway to better integrate information from third parties. TI has taken and continues to take reasonable steps to provide representative and accurate information but may not have conducted destructive testing or chemical analysis on incoming materials and chemicals. TI and TI suppliers consider certain information to be proprietary, and thus CAS numbers and other limited information may not be available for release.

In no event shall TI's liability arising out of such information exceed the total purchase price of the TI part(s) at issue in this document sold by TI to Customer on an annual basis.

OTHER QUALIFIED VERSIONS OF ADS5204-Q1 :

- Catalog: [ADS5204](#)

NOTE: Qualified Version Definitions:

- Catalog - TI's standard catalog product

TAPE AND REEL INFORMATION
REEL DIMENSIONS

TAPE DIMENSIONS

A0	Dimension designed to accommodate the component width
B0	Dimension designed to accommodate the component length
K0	Dimension designed to accommodate the component thickness
W	Overall width of the carrier tape
P1	Pitch between successive cavity centers

TAPE AND REEL INFORMATION

*All dimensions are nominal

Device	Package Type	Package Drawing	Pins	SPQ	Reel Diameter (mm)	Reel Width W1 (mm)	A0 (mm)	B0 (mm)	K0 (mm)	P1 (mm)	W (mm)	Pin1 Quadrant
ADS5204IPFBRG4Q1	TQFP	PFB	48	1000	330.0	16.4	9.6	9.6	1.5	12.0	16.0	Q2
ADS5204IPFBRQ1	TQFP	PFB	48	1000	330.0	16.4	9.6	9.6	1.5	12.0	16.0	Q2

TAPE AND REEL BOX DIMENSIONS

*All dimensions are nominal

Device	Package Type	Package Drawing	Pins	SPQ	Length (mm)	Width (mm)	Height (mm)
ADS5204IPFBRG4Q1	TQFP	PFB	48	1000	367.0	367.0	38.0
ADS5204IPFBRQ1	TQFP	PFB	48	1000	367.0	367.0	38.0

PFB (S-PQFP-G48)

PLASTIC QUAD FLATPACK

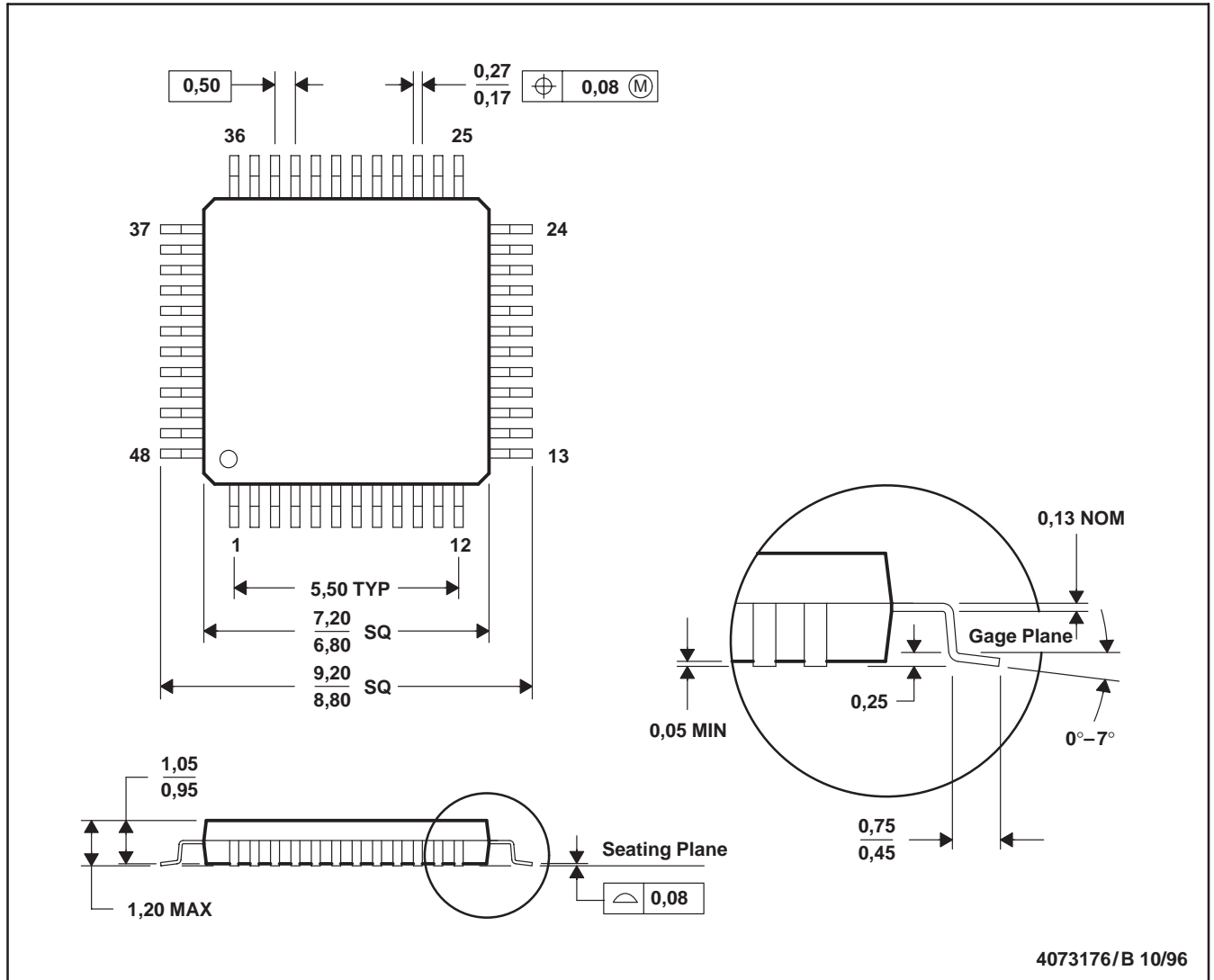

- NOTES: A. All linear dimensions are in millimeters.
 B. This drawing is subject to change without notice.
 C. Falls within JEDEC MS-026

PFB (S-PQFP-G48)



- NOTES:
- A. All linear dimensions are in millimeters.
 - B. This drawing is subject to change without notice.
 - C. Publication IPC-7351 is recommended for alternate designs.
 - D. Laser cutting apertures with trapezoidal walls and also rounding corners will offer better paste release. Customers should contact their board assembly site for stencil design recommendations. Refer to IPC-7525.
 - E. Customers should contact their board fabrication site for solder mask tolerances between and around signal pads.

IMPORTANT NOTICE

Texas Instruments Incorporated and its subsidiaries (TI) reserve the right to make corrections, enhancements, improvements and other changes to its semiconductor products and services per JESD46C and to discontinue any product or service per JESD48B. Buyers should obtain the latest relevant information before placing orders and should verify that such information is current and complete. All semiconductor products (also referred to herein as "components") are sold subject to TI's terms and conditions of sale supplied at the time of order acknowledgment.

TI warrants performance of its components to the specifications applicable at the time of sale, in accordance with the warranty in TI's terms and conditions of sale of semiconductor products. Testing and other quality control techniques are used to the extent TI deems necessary to support this warranty. Except where mandated by applicable law, testing of all parameters of each component is not necessarily performed.

TI assumes no liability for applications assistance or the design of Buyers' products. Buyers are responsible for their products and applications using TI components. To minimize the risks associated with Buyers' products and applications, Buyers should provide adequate design and operating safeguards.

TI does not warrant or represent that any license, either express or implied, is granted under any patent right, copyright, mask work right, or other intellectual property right relating to any combination, machine, or process in which TI components or services are used. Information published by TI regarding third-party products or services does not constitute a license to use such products or services or a warranty or endorsement thereof. Use of such information may require a license from a third party under the patents or other intellectual property of the third party, or a license from TI under the patents or other intellectual property of TI.

Reproduction of significant portions of TI information in TI data books or data sheets is permissible only if reproduction is without alteration and is accompanied by all associated warranties, conditions, limitations, and notices. TI is not responsible or liable for such altered documentation. Information of third parties may be subject to additional restrictions.

Resale of TI components or services with statements different from or beyond the parameters stated by TI for that component or service voids all express and any implied warranties for the associated TI component or service and is an unfair and deceptive business practice. TI is not responsible or liable for any such statements.

Buyer acknowledges and agrees that it is solely responsible for compliance with all legal, regulatory and safety-related requirements concerning its products, and any use of TI components in its applications, notwithstanding any applications-related information or support that may be provided by TI. Buyer represents and agrees that it has all the necessary expertise to create and implement safeguards which anticipate dangerous consequences of failures, monitor failures and their consequences, lessen the likelihood of failures that might cause harm and take appropriate remedial actions. Buyer will fully indemnify TI and its representatives against any damages arising out of the use of any TI components in safety-critical applications.

In some cases, TI components may be promoted specifically to facilitate safety-related applications. With such components, TI's goal is to help enable customers to design and create their own end-product solutions that meet applicable functional safety standards and requirements. Nonetheless, such components are subject to these terms.

No TI components are authorized for use in FDA Class III (or similar life-critical medical equipment) unless authorized officers of the parties have executed a special agreement specifically governing such use.

Only those TI components which TI has specifically designated as military grade or "enhanced plastic" are designed and intended for use in military/aerospace applications or environments. Buyer acknowledges and agrees that any military or aerospace use of TI components which have **not** been so designated is solely at the Buyer's risk, and that Buyer is solely responsible for compliance with all legal and regulatory requirements in connection with such use.

TI has specifically designated certain components which meet ISO/TS16949 requirements, mainly for automotive use. Components which have not been so designated are neither designed nor intended for automotive use; and TI will not be responsible for any failure of such components to meet such requirements.

Products

Audio	www.ti.com/audio
Amplifiers	amplifier.ti.com
Data Converters	dataconverter.ti.com
DLP® Products	www.dlp.com
DSP	dsp.ti.com
Clocks and Timers	www.ti.com/clocks
Interface	interface.ti.com
Logic	logic.ti.com
Power Mgmt	power.ti.com
Microcontrollers	microcontroller.ti.com
RFID	www.ti-rfid.com
OMAP Mobile Processors	www.ti.com/omap
Wireless Connectivity	www.ti.com/wirelessconnectivity

Applications

Automotive and Transportation	www.ti.com/automotive
Communications and Telecom	www.ti.com/communications
Computers and Peripherals	www.ti.com/computers
Consumer Electronics	www.ti.com/consumer-apps
Energy and Lighting	www.ti.com/energy
Industrial	www.ti.com/industrial
Medical	www.ti.com/medical
Security	www.ti.com/security
Space, Avionics and Defense	www.ti.com/space-avionics-defense
Video and Imaging	www.ti.com/video

TI E2E Community e2e.ti.com

Mouser Electronics

Authorized Distributor

Click to View Pricing, Inventory, Delivery & Lifecycle Information:

[Texas Instruments:](#)

[ADS5204IPFBRG4Q1](#) [ADS5204IPFBRQ1](#)