

Sep.1.2025 Copyright 2025 HIROSE ELECTRIC CO., LTD. All Rights Reserved.  
In case of consideration for using Automotive equipment / device which demand high reliability, kindly contact our sales window correspondents.

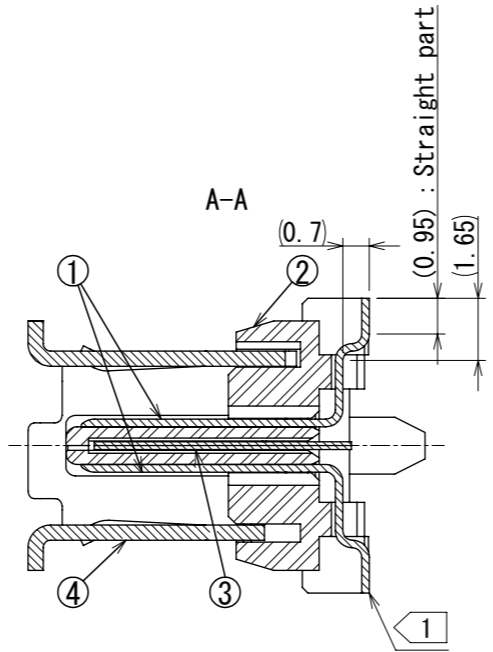

- Notes.
- 1 Co-planarity is within 0.1 mm.
  - 2 As for part No.4 the performance remains good though there might be a difference in the plating luster between each plating lots.
  - 3 Per reel : 450 pcs.  
The vacuum cap(part No.5) is attached to this product at delivery.
  - 4 Refer to the mated condition diagram for the panel thickness and layout.
  - 5 This product is mounted by reflow soldering.  
Refer to specification sheet ELC-129413-00-00 for reflow soldering.

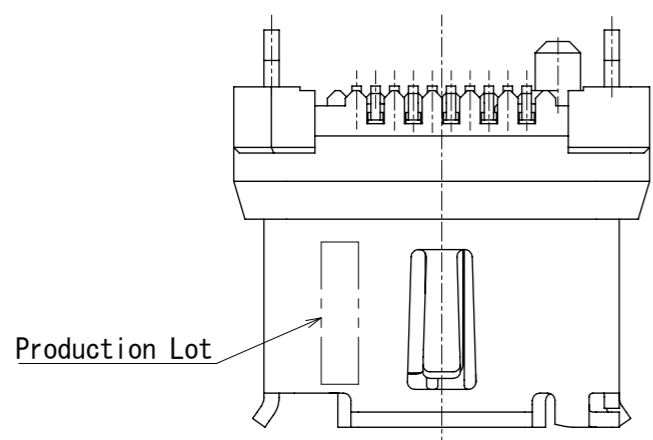
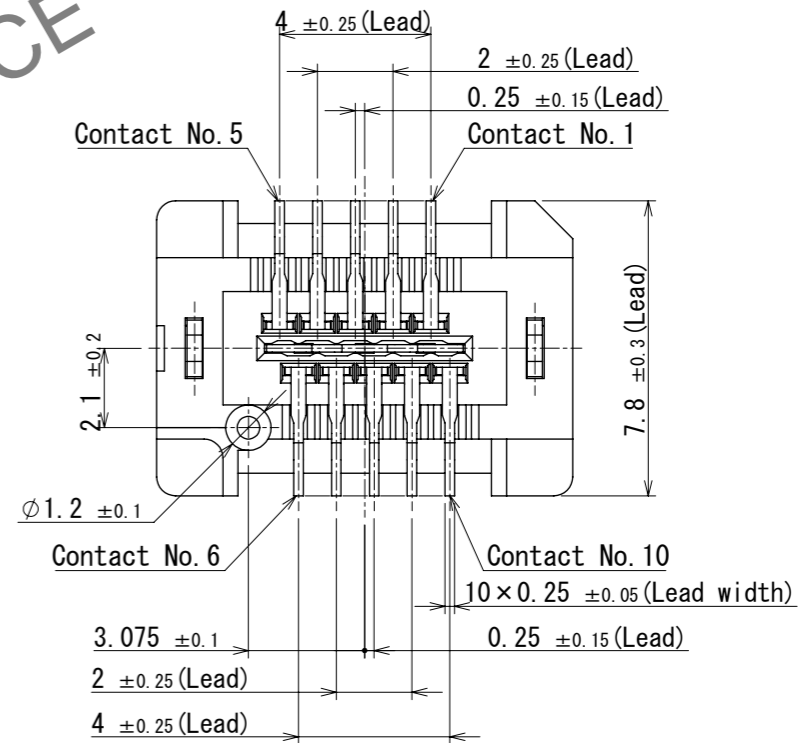
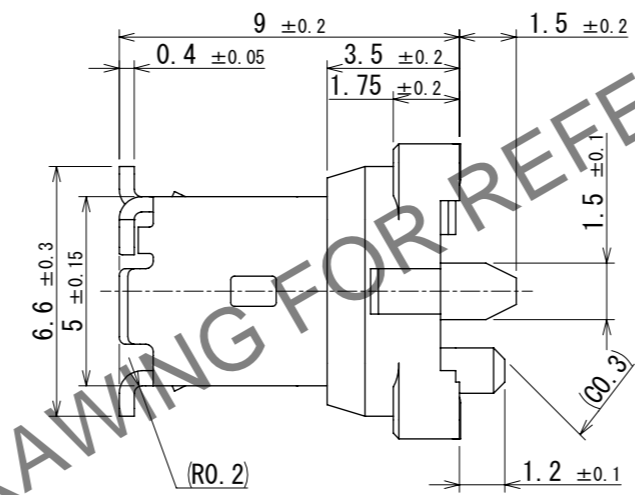
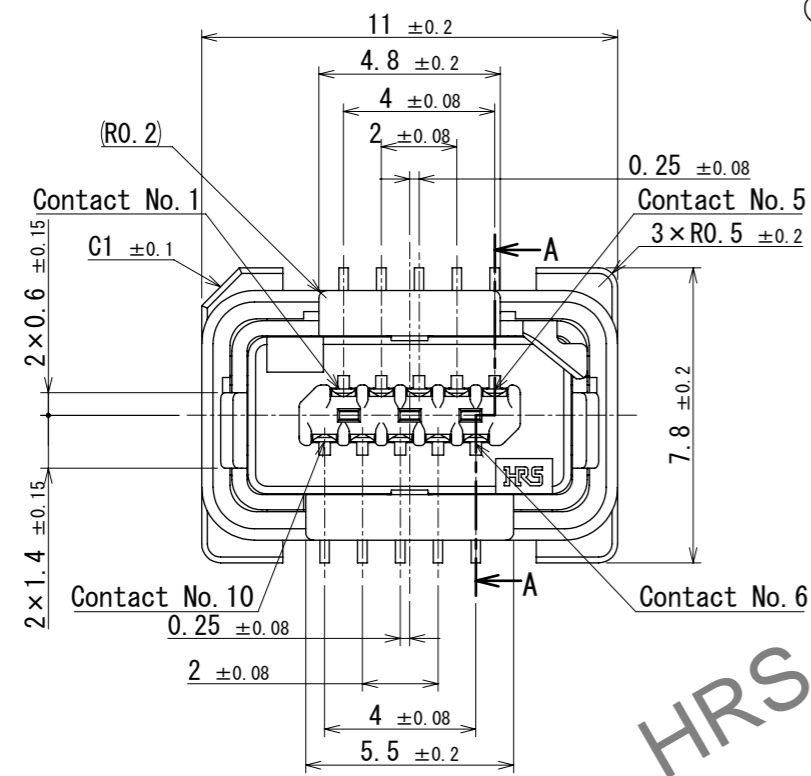

3D image

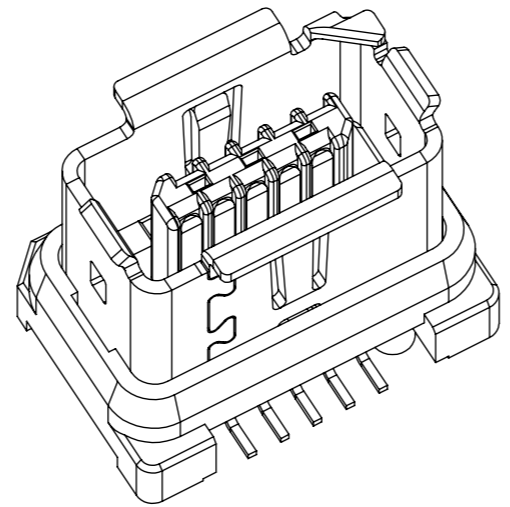
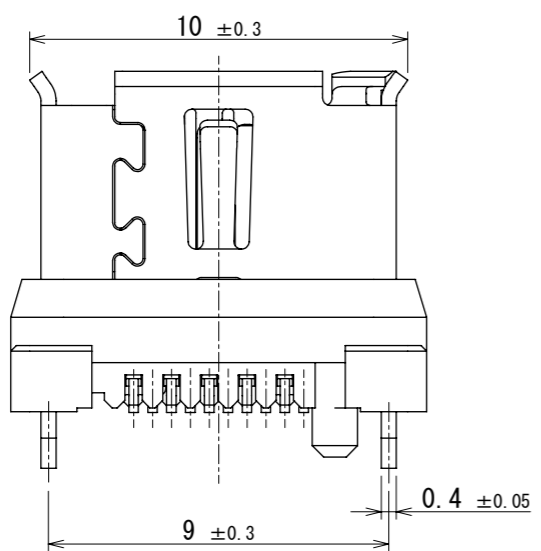

3	Stainless Steel		7	PET				
2	PA	Gray, UL94V-0	6	PS				
1	Copper Alloy	Contact area : Gold 0.2µm min. Lead area : Gold 0.03µm min. Under plating : Nickel 2µm min.	5	PA	Black, UL94V-0			
			4	Stainless Steel	Surface : Tin 1µm min. Under plating : Nickel 0.2µm min.			
NO.	MATERIAL	FINISH	REMARKS	NO.	MATERIAL	FINISH	REMARKS	
UNITS		SCALE	COUNT	DESCRIPTION OF REVISIONS		DESIGNED	CHECKED	DATE
mm		5:1		3	DIS-E-00011281	SN. TOYOSHIMA	KI. KAGOTANI	2022. 10. 04
<b>HRS</b> HIROSE ELECTRIC CO., LTD.		APPROVED : RI. TAKAYASU	2018. 04. 23	DRAWING NO.		EDC-129413-00-00		
		CHECKED : KI. NAGANUMA	2018. 04. 20	PART NO.		IX80G-B-10P		
		DESIGNED : YS. SAKODA	2018. 04. 20	CODE NO.		CL0251-0019-0-00		
		DRAWN : YS. SAKODA	2018. 04. 20			1/3		

Sep.1.2025 Copyright 2025 HIROSE ELECTRIC CO., LTD. All Rights Reserved.  
 In case of consideration for using Automotive equipment / device which demand high reliability, kindly contact our sales window correspondents.

Reference PCB Layout (Connector Mounting Side) (t=1.6)

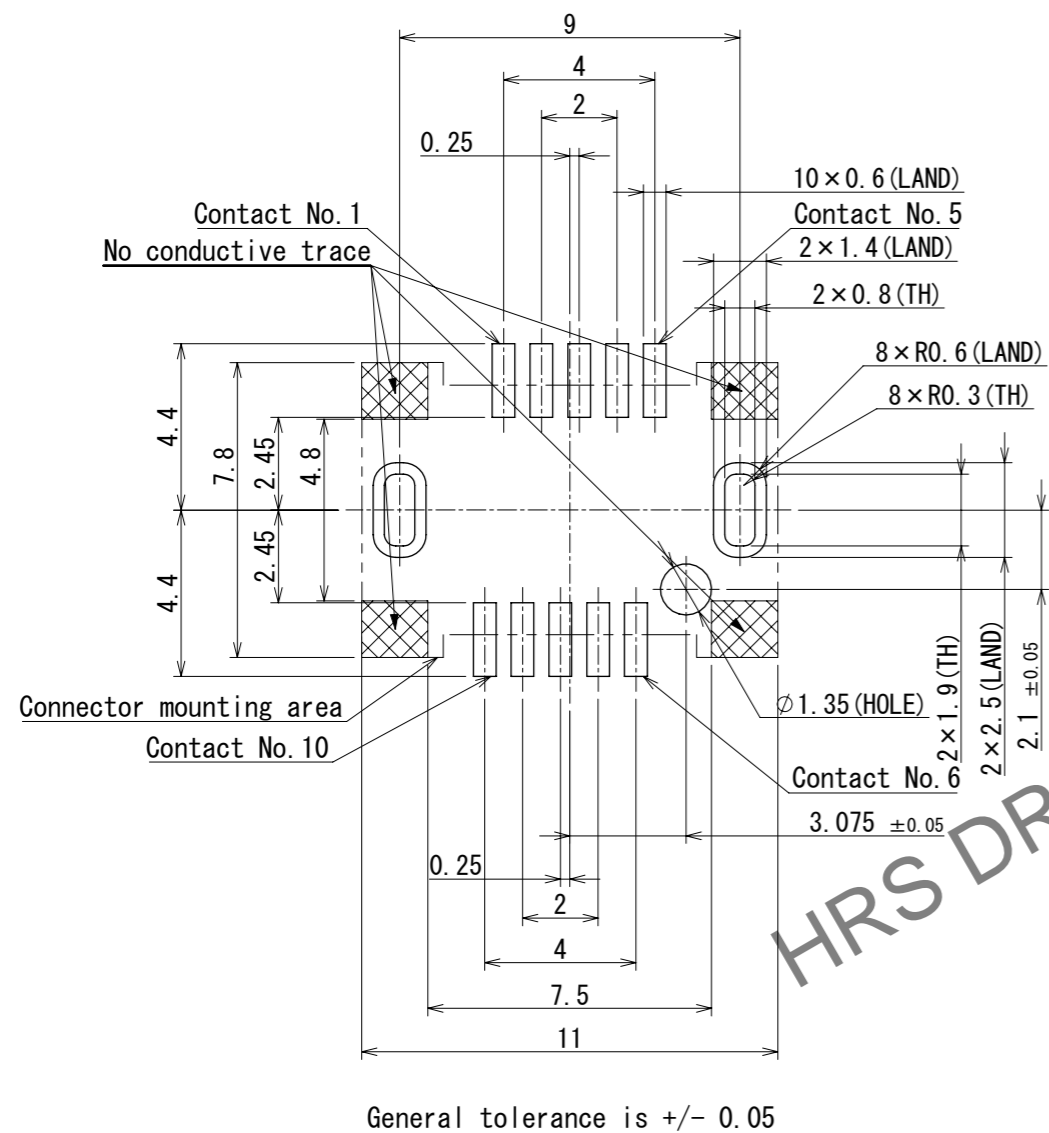

6 Reference Metal Mask Layout (t=0.15)

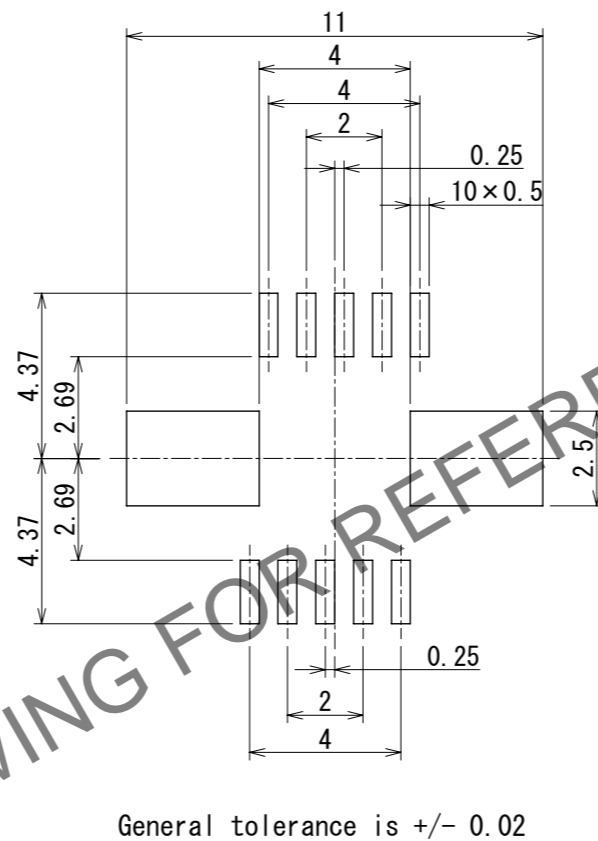

Mated Condition (Free)

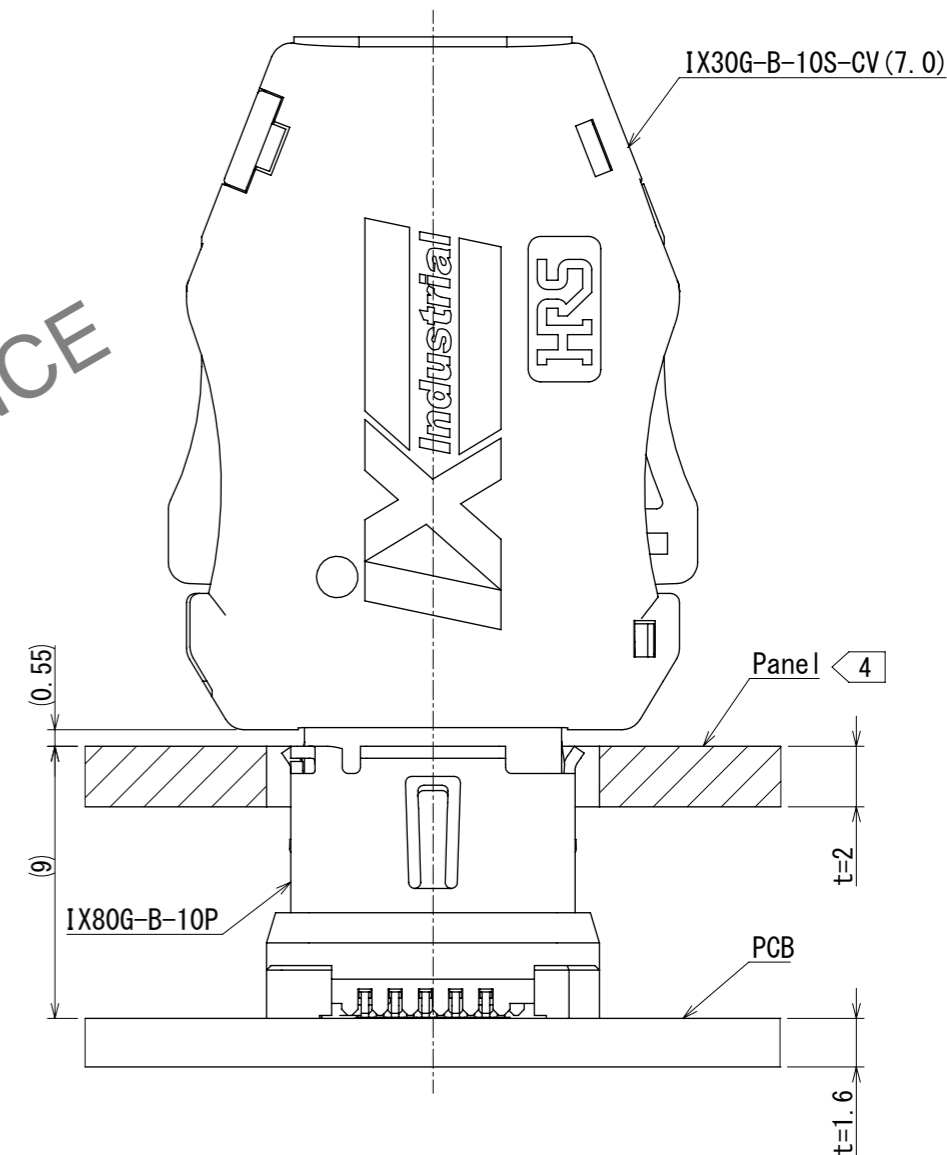

4 Reference Dimensions of Panel Cutout (Free)

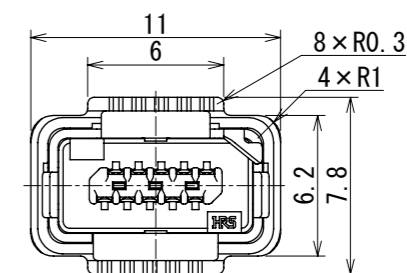

- Notes. 6 Thickness of metal mask is 0.1mm min.  
 Metal mask dimensions of the drawings described, are reference dimensions for 0.15mm thickness metal mask.  
 Gange the metal mask dimensions by thickness of the metal mask, thickness of PCB, component of solder paste and mounting conditions.  
 Gange the metal mask dimensions in case of mounting IX80G-\*10P in parallel.  
 Gange the metal mask dimensions, if there are other mounting parts or implementation pattern around the portion of mounting position of IX80G-\*10P.

<b>HRS</b>	DRAWING NO.	EDC-129413-00-00	2/3
	PART NO.	IX80G-B-10P	
	CODE NO.	CL0251-0019-0-00	
	NO.		

Sep.1.2025 Copyright 2025 HIROSE ELECTRIC CO., LTD. All Rights Reserved.  
In case of consideration for using Automotive equipment / device which demand high reliability, kindly contact our sales window correspondents.

△ 3 Drawing for packing (Free)

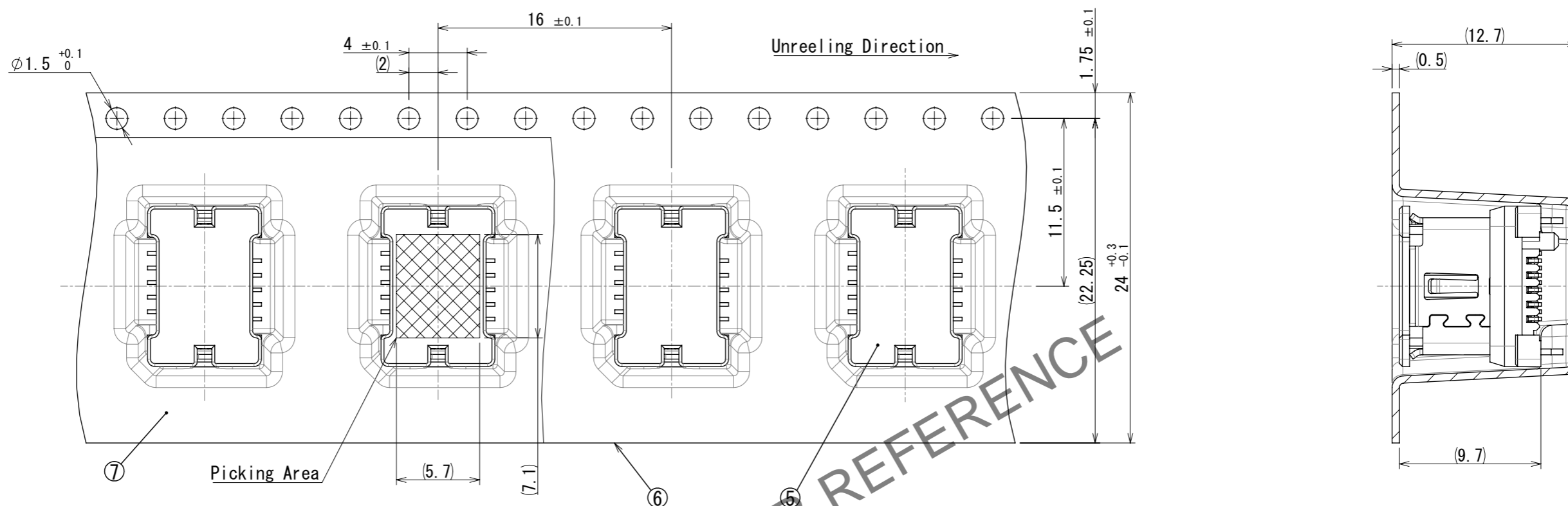

Notes. 7. This product (Type B) is used for non Ethernet applications like signaling, serial or other industrial bus communication systems. Please use Type A for 10/100Mbit/s and 1/10Gbit/s Ethernet communication.

Mating Shape

Type A

Type B

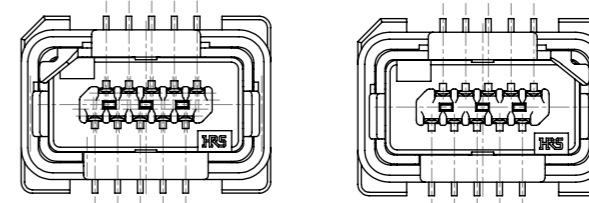

Unleering Direction

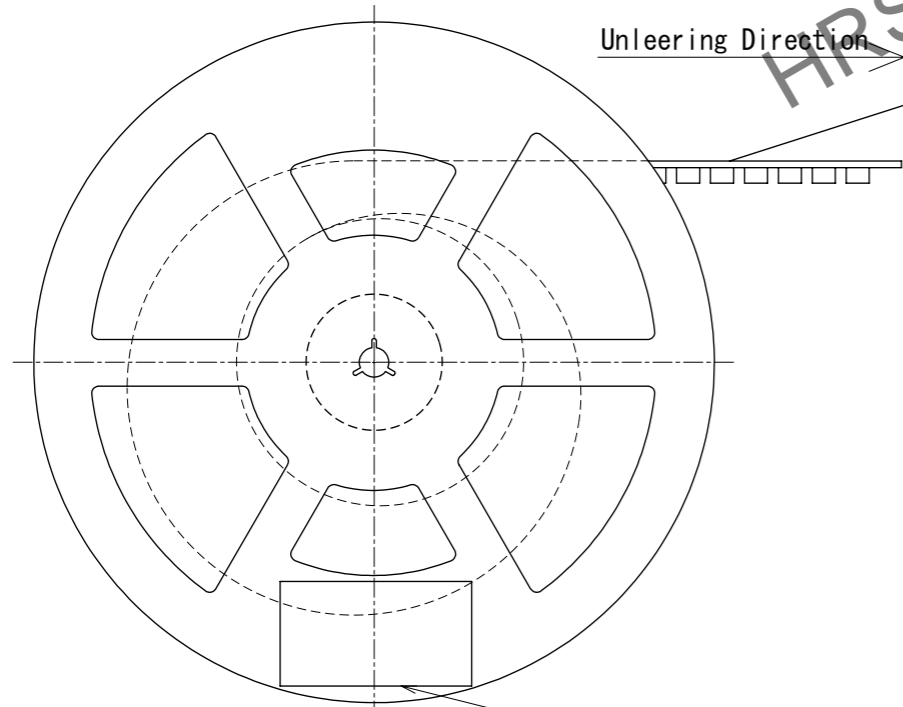

Label (Part No., Code No., Lot No., Packing Quantity)

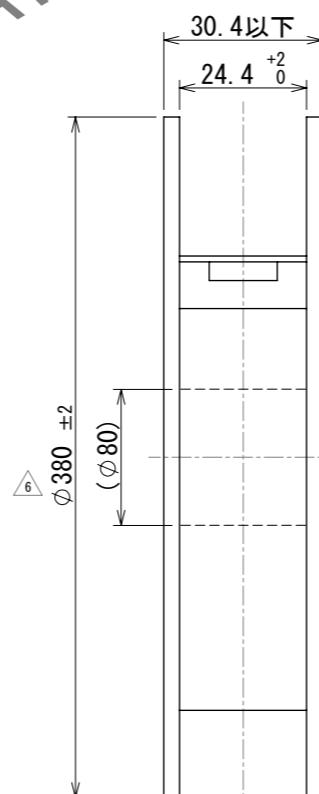

<b>HRS</b>	DRAWING NO.	EDC-129413-00-00	△ 3 / 3
	PART NO.	IX80G-B-10P	
	CODE NO.	CL0251-0019-0-00	
	NO.		