

Universal Load Cell



FEATURES

- Capacities: 50–5000 kg, 100–10k lbs.
- Fully-welded, stainless-steel construction
- Hermetically sealed, IP66 and IP68
- Certified to OIML R-60, 3000d
- Integrated overload stop (50–500 kg)
- Current calibration output (SC version) ensures easy and accurate parallel connection of multiple load cells
- **Optional**
 - FM Approved, ATEX and UKCA certified versions for use in potentially-explosive atmospheres



APPLICATIONS

- Hybrid scales
- Process weighing
- Belt checkweighers
- Dynamometers
- Material testing machines

The product is suitable for a wide range of hybrid scales, overhead track scales, belt scales, and process-weighing applications.

The fully-welded construction and water block cable entry ensure that this product can be used successfully in the demanding environments found in the food, chemical, and allied process industries.

DESCRIPTION

Model BSP is a stainless-steel S-type load cell that can be used in either tension or compression.

The product fully meets the stringent Weights and Measures requirements throughout Europe.

OUTLINE DIMENSIONS in millimeters

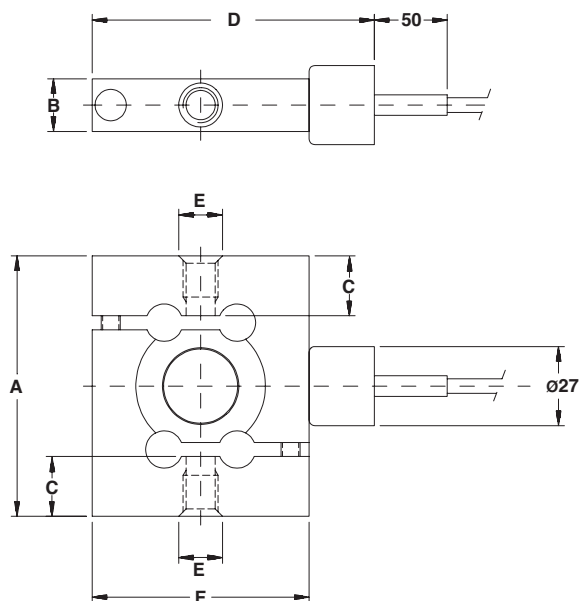

Cable specifications

Cable length: 10m

Excitation +	Green
Excitation -	Black
Output +	White
Output -	Red
Shield	Transparent

Cable screen is not connected to the load cell body. Performance may be affected if load cell cables are shortened. Tension applications result in a negative output signal.

Capacity (kg)	50, 125	250	500	1250	2500, 5000
A	84.3	88.9	88.9	95.2	120.6
B	23.9	18.0	18.0	24.1	36.6
C thread	12.7	14.0	14.0	14.0	29.2
D	85.7	84.1	96.8	84.1	84.1
E	M8x1.25		M12x1		M24x2
F	63.5	61.9	74.6	61.9	61.9

Capacity (lb)	100, 250	500	1k	2.5k	5k, 10k
A	3.32	3.50	3.50	3.75	4.75
F	2.48	2.44	2.94	2.44	2.44
B	0.94	0.71	0.71	0.95	1.44
D	3.36	3.32	3.81	3.31	3.31
E threads	3/8-24UNF-3B		1/2-20 UNF-3B		1-14 UNS-3B

Universal Load Cell

SPECIFICATIONS				
PARAMETER	VALUE			UNIT
Standard capacities (E _{max})	50, 125, 250, 500, 1250, 2500, 5000			kg
Standard capacities (E _{max})	100, 250, 500, 1000, 2500, 5000, 10000			lbs
Accuracy class according to OIML R-60 /NTEP	NTEP IIIIL	Non-Approved	C3	
Maximum number of verification intervals	10000		3000	
Minimum verification interval = V _{min} /E _{max} /Y			E _{max} /10000	
Rated output (=S)	3 (2 for 2500 and 5000 kg)			mV/V
Rated output tolerance	0.03 (0.02 for 2500 and 5000 kg)			± mV/V
Zero balance	1.0			±% FSO
Combined error	0.0200	0.0500	0.0200	±% FSO
Non-repeatability	0.0100	0.0200	0.0100	±% FSO
Minimum dead load output return		0.0500	0.0167	±% FSO
Creep error (30 minutes)		0.0600	0.0245	±% FSO
Creep error (20–30 minutes)	0.0300	0.0200		±% FSO
Temp. effect on minimum dead load output	(0.0008)	0.0250	0.0070	±% FSO/5°C (°F)
Temperature effect on sensitivity	(0.0010)	0.0250	0.0050	±% FSO/5°C (°F)
Minimum dead load	0			% E _{max}
Maximum safe overload	150			% E _{max}
Ultimate overload	300			% E _{max}
Maximum safe side load	100			% E _{max}
Deflection at E _{max}	0.28 max.			mm
Excitation voltage	5 to 15			V
Maximum excitation voltage	18			V
Input resistance	350±3.5			Ω
Output resistance	350±3.5			Ω
Insulation resistance	≥5000			MΩ
Compensated temperature range	-10 to +40			°C
Operating temperature range	-40 to +80			°C
Storage temperature range	-40 to +90			°C
Element material (DIN)	Stainless steel 1.4542			
Sealing (DIN 40.050 / EN60.529)	IP66 and IP68			
SC-Version (current calibration)	Standard			

FSO—Full Scale Output

SC-version: The rated output and the output resistance are balanced in such a way that the output current is calibrated to within 0.05% of a reference value. This allows easy parallel connection of the load cells.

All specifications subject to change without notice.

CERTIFICATION MARKINGS

ATEX & UKEX Markings (For Zone 1, 2 and Zone 21, 22)

II 2 G Ex ib IIC T6...T4 Gb
 II 2 D Ex ib IIIC T70°C Db
 II 2 D Ex tb IIIC T70°C Db

II 3 G Ex ic IIC T6...T4 Gc or Ex nA IIC T6...T4 Gc
 II 3 D Ex ic IIIC T70°C Dc or Ex tc IIIC T70°C Dc

FM Approval Markings (USA and Canada)

IS Class I, II, III, Division 1, Groups A, B, C, D, E, F and G;
 NI Class I, Division 2, Groups A, B, C, and D;
 DIP Class II, III, Division 2, Groups F and G;
 T4;
 Ta = -25°C to +40°C;



Disclaimer

ALL PRODUCTS, PRODUCT SPECIFICATIONS AND DATA ARE SUBJECT TO CHANGE WITHOUT NOTICE.

Vishay Precision Group, Inc., its affiliates, agents, and employees, and all persons acting on its or their behalf (collectively, "VPG"), disclaim any and all liability for any errors, inaccuracies or incompleteness contained herein or in any other disclosure relating to any product.

The product specifications do not expand or otherwise modify VPG's terms and conditions of purchase, including but not limited to, the warranty expressed therein.

VPG makes no warranty, representation or guarantee other than as set forth in the terms and conditions of purchase. **To the maximum extent permitted by applicable law, VPG disclaims (i) any and all liability arising out of the application or use of any product, (ii) any and all liability, including without limitation special, consequential or incidental damages, and (iii) any and all implied warranties, including warranties of fitness for particular purpose, non-infringement and merchantability.**

Information provided in datasheets and/or specifications may vary from actual results in different applications and performance may vary over time. Statements regarding the suitability of products for certain types of applications are based on VPG's knowledge of typical requirements that are often placed on VPG products. It is the customer's responsibility to validate that a particular product with the properties described in the product specification is suitable for use in a particular application. You should ensure you have the current version of the relevant information by contacting VPG prior to performing installation or use of the product, such as on our website at vpgsensors.com.

No license, express, implied, or otherwise, to any intellectual property rights is granted by this document, or by any conduct of VPG.

The products shown herein are not designed for use in life-saving or life-sustaining applications unless otherwise expressly indicated. Customers using or selling VPG products not expressly indicated for use in such applications do so entirely at their own risk and agree to fully indemnify VPG for any damages arising or resulting from such use or sale. Please contact authorized VPG personnel to obtain written terms and conditions regarding products designed for such applications.

Product names and markings noted herein may be trademarks of their respective owners.

Copyright Vishay Precision Group, Inc., 2014. All rights reserved.