

ESP32-C6-WROOM-1

Datasheet

Module that supports 2.4 GHz Wi-Fi 6 (802.11 ax), Bluetooth® 5 (LE), Zigbee and Thread (802.15.4)

Built around ESP32-C6 series of SoCs, 32-bit RISC-V single-core microprocessor
4 MB flash

23 GPIOs, rich set of peripherals

On-board PCB antenna



ESP32-C6-WROOM-1



Pre-release v0.1
Espressif Systems
Copyright © 2022

1 Module Overview

1.1 Features

CPU and On-Chip Memory

- ESP32-C6 embedded, 32-bit RISC-V single-core microprocessor, up to 160 MHz
- 320 KB ROM
- 512 KB SRAM
- 16 KB Low-power (LP) SRAM

Wi-Fi

- 1T1R in 2.4 GHz band
- Operating frequency: 2412 ~ 2484 MHz
- IEEE 802.11ax-compliant
 - 20 MHz-only non-AP mode
 - MCS0 ~MCS9
 - Uplink and downlink OFDMA, especially suitable for simultaneous connections in high-density environments
 - Downlink MU-MIMO (multi-user, multiple input, multiple output) to increase network capacity
 - Beamformee that improves signal quality
 - Channel quality indication (CQI)
 - DCM (dual carrier modulation) to improve link robustness
 - Spatial reuse to maximize parallel transmissions
 - Target wake time (TWT) that optimizes power saving mechanisms
- Fully compatible with IEEE 802.11b/g/n protocol
 - 20 MHz and 40 MHz bandwidth
 - Data rate up to 150 Mbps
 - Wi-Fi Multimedia (WMM)
 - TX/RX A-MPDU, TX/RX A-MSDU

- Immediate Block ACK
- Fragmentation and defragmentation
- Transmit opportunity (TXOP)
- Automatic Beacon monitoring (hardware TSF)
- 4 × virtual Wi-Fi interfaces
- Simultaneous support for Infrastructure BSS in Station mode, SoftAP mode, Station + SoftAP mode, and promiscuous mode

Note that when ESP32-C6 scans in Station mode, the SoftAP channel will change along with the Station channel

 - Antenna diversity
 - 802.11mc FTM

Bluetooth

- Bluetooth LE: Bluetooth 5, Bluetooth mesh
- High power mode (share the same PA with Wi-Fi)
- Speed: 125 Kbps, 500 Kbps, 1 Mbps, 2 Mbps
- Advertising extensions
- Multiple advertisement sets
- Channel selection algorithm #2

IEEE 802.15.4

- Compliant with IEEE 802.15.4-2015 protocol
- OQPSK PHY in 2.4 GHz band
- Data rate: 250 Kbps
- Thread 1.x
- Zigbee 3.0

Peripherals

- GPIO, SPI, parallel IO interface, UART, I2C, I2S, RMT (TX/RX), pulse counter, LED PWM, USB

Serial/JTAG controller, MCPWM, SDIO2.0 slave controller, GDMA, TWAI® controller, on-chip debug functionality via JTAG, SOC event task matrix, ADC, temperature sensor, general-purpose timers, watchdog timers, etc.

Integrated Components on Module

- 40 MHz crystal oscillator
- 4 MB SPI flash

1.2 Description

ESP32-C6-WROOM-1 is a general-purpose Wi-Fi, IEEE 802.15.4, and Bluetooth LE module. The rich set of peripherals and high performance make the module an ideal choice for smart homes, industrial automation, health care, consumer electronics, etc.

ESP32-C6-WROOM-1 module features a 4 MB external SPI flash.

The ordering information for ESP32-C6-WROOM-1 is as follows:

Table 1: ESP32-C6-WROOM-1 Ordering Information

Ordering Code	Flash	Ambient Temp. ¹ (°C)	Size ² (mm)
ESP32-C6-WROOM-1-N4	4 MB (Quad SPI)	-40 ~ 85	18.0 × 25.5 × 3.1
ESP32-C6-WROOM-1-H4	4 MB (Quad SPI)	-40 ~ 105	

¹ Ambient temperature specifies the recommended temperature range of the environment immediately outside the Espressif module.

² For details, refer to Section 7.1 *Physical Dimensions*.

At the core of this module is ESP32-C6, a 32-bit RISC-V single-core processor.

ESP32-C6 integrates a rich set of peripherals including SPI, parallel IO interface, UART, I2C, I2S, RMT (TX/RX), LED PWM, USB Serial/JTAG controller, MCPWM, SDIO2.0 slave controller, GDMA, TWAI® controller, on-chip debug functionality via JTAG, SOC event task matrix, as well as up to 23 GPIOs, etc.

1.3 Applications

- [Smart Home](#)
- [Industrial Automation](#)
- [Health Care](#)
- [Consumer Electronics](#)
- Smart Agriculture
- POS machines
- Service robot
- Audio Devices
- Generic Low-power IoT Sensor Hubs
- Generic Low-power IoT Data Loggers

Contents

1	Module Overview	2
1.1	Features	2
1.2	Description	3
1.3	Applications	3
2	Block Diagram	7
3	Pin Definitions	8
3.1	Pin Layout	8
3.2	Pin Description	8
3.3	Strapping Pins	9
3.3.1	SDIO Sampling and Driving Clock Edge Control	10
3.3.2	Chip Boot Mode Control	10
3.3.3	ROM Code Printing Control	11
3.3.4	JTAG Signal Source Control	11
4	Electrical Characteristics	12
4.1	Absolute Maximum Ratings	12
4.2	Recommended Operating Conditions	12
4.3	DC Characteristics (3.3 V, 25 °C)	12
5	Module Schematics	14
6	Peripheral Schematics	15
7	Physical Dimensions and PCB Land Pattern	16
7.1	Physical Dimensions	16
7.2	Recommended PCB Land Pattern	17
8	Product Handling	18
8.1	Storage Conditions	18
8.2	Electrostatic Discharge (ESD)	18
8.3	Soldering Profile	18
8.3.1	Reflow Profile	18
8.4	Ultrasonic Vibration	19
9	Related Documentation and Resources	20
	Revision History	21

List of Tables

1	ESP32-C6-WROOM-1 Ordering Information	3
2	Pin Definitions	8
3	Default Configuration of Strapping Pins	10
4	SDIO Sampling and Driving Clock Edge Control	10
5	Boot Mode Control	10
6	ROM Code Printing Control	11
7	JTAG Signal Source Control	11
8	Absolute Maximum Ratings	12
9	Recommended Operating Conditions	12
10	DC Characteristics (3.3 V, 25 °C)	12

List of Figures

1	ESP32-C6-WROOM-1 Block Diagram	7
2	Pin Layout (Top View)	8
3	ESP32-C6-WROOM-1 Schematics	14
4	Peripheral Schematics	15
5	Physical Dimensions	16
6	Recommended PCB Land Pattern	17
7	Reflow Profile	18

PRELIMINARY

2 Block Diagram

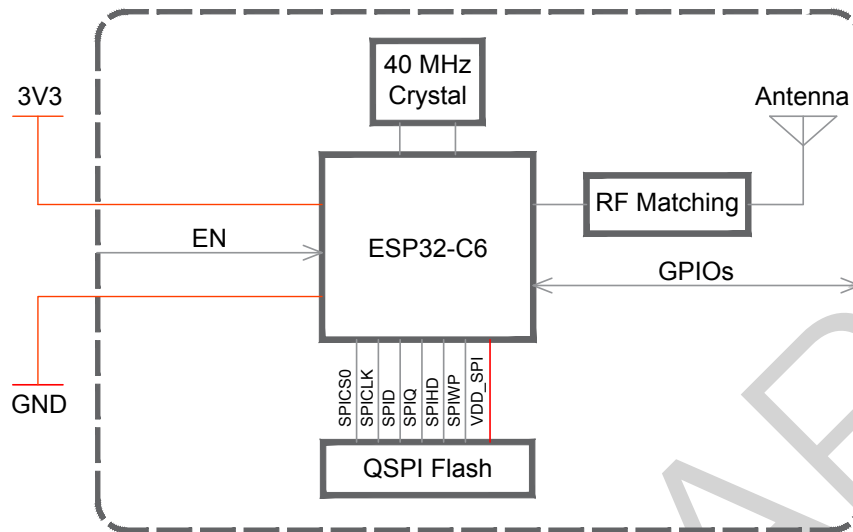

Figure 1: ESP32-C6-WROOM-1 Block Diagram

3 Pin Definitions

3.1 Pin Layout

The pin diagram below shows the approximate location of pins on the module. For the actual diagram drawn to scale, please refer to Figure 7.1 *Physical Dimensions*.

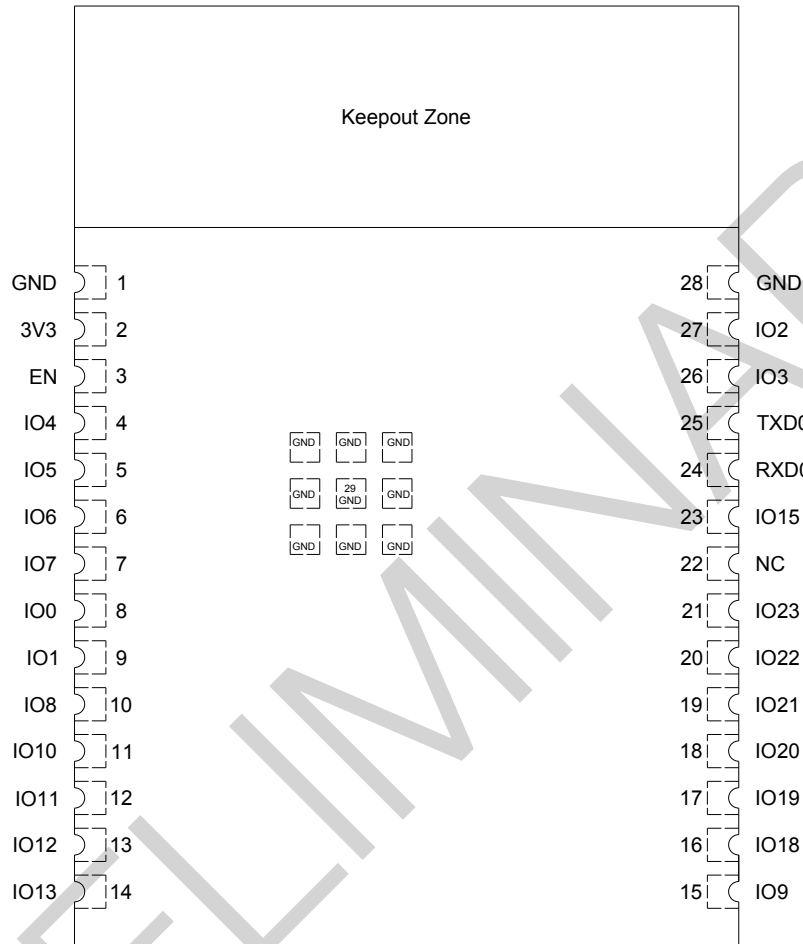

Figure 2: Pin Layout (Top View)

3.2 Pin Description

The module has 29 pins. See pin definitions in Table 2 *Pin Definitions*.

Table 2: Pin Definitions

Name	No.	Type ¹	Function
GND	1	P	Ground
3V3	2	P	Power supply
EN	3	I	High: on, enables the chip. Low: off, the chip powers off. Note: Do not leave the EN pin floating.

Cont'd on next page

Table 2 – cont'd from previous page

Name	No.	Type ¹	Function
IO4	4	I/O/T	MTMS, GPIO4, LP_GPIO4, LP_UART_RXD, ADC1_CH4, FSPiHD
IO5	5	I/O/T	MTDI, GPIO5, LP_GPIO5, LP_UART_TXD, ADC1_CH5, FSPiWP
IO6	6	I/O/T	MTCK, GPIO6, LP_GPIO6, LP_I2C_SDA, ADC1_CH6, FSPiCLK
IO7	7	I/O/T	MTDO, GPIO7, LP_GPIO7, LP_I2C_SCL, FSPiD
IO0	8	I/O/T	GPIO0, XTAL_32K_P, LP_GPIO0, LP_UART_DTRN, ADC1_CH0
IO1	9	I/O/T	GPIO1, XTAL_32K_N, LP_GPIO1, LP_UART_DSRN, ADC1_CH1
IO8	10	I/O/T	GPIO8
IO10	11	I/O/T	GPIO10
IO11	12	I/O/T	GPIO11
IO12	13	I/O/T	GPIO12, USB_D-
IO13	14	I/O/T	GPIO13, USB_D+
IO9	15	I/O/T	GPIO9
IO18	16	I/O/T	GPIO18 SDIO_CMD FSPiCS2
IO19	17	I/O/T	GPIO19 SDIO_CLK FSPiCS3
IO20	18	I/O/T	GPIO20 SDIO_DATA0 FSPiCS4
IO21	19	I/O/T	GPIO21 SDIO_DATA1 FSPiCS5
IO22	20	I/O/T	GPIO22 SDIO_DATA2
IO23	21	I/O/T	GPIO23 SDIO_DATA3
NC	22	—	NC
IO15	23	I/O/T	GPIO15
RXD0	24	I/O/T	U0RXD GPIO17 FSPiCS1
TXD0	25	I/O/T	U0TXD GPIO16 FSPiCS0
IO3	26	I/O/T	GPIO3, LP_GPIO3, LP_UART_CTSN, ADC1_CH3
IO2	27	I/O/T	GPIO2, LP_GPIO2, LP_UART_RTSN, ADC1_CH2, FSPiQ
GND	28	P	Ground
EPAD	29	P	Ground

¹ P: power supply; I: input; O: output; T: high impedance.

3.3 Strapping Pins

Note:

The content below is excerpted from *ESP32-C6 Series Datasheet* > Section *Strapping Pins*. For the strapping pin mapping between the chip and modules, please refer to Chapter 5 *Module Schematics*

At each startup or reset, a chip requires some initial configuration parameters, such as in which boot mode to load the chip, etc. These parameters are passed over via the strapping pins. After reset, the strapping pins work as normal function pins.

ESP32-C6 has the following parameters controlled by the given strapping pins at chip reset:

- **SDIO sampling and driving clock edge** – MTMS and MTDI
- **Chip boot mode** – GPIO8 and GPIO9
- **ROM code printing to UART** – GPIO8

- **JTAG signal source** – GPIO15

GPIO9 is connected to the chip's internal weak pull-up resistor at chip reset. This resistor determines the default bit value of GPIO9. Also, the resistor determines the bit value if GPIO9 is connected to an external high-impedance circuit.

Table 3: Default Configuration of Strapping Pins

Strapping Pin	Default Config	Bit Value
MTMS	Floating	–
MTDI	Floating	–
GPIO8	Floating	–
GPIO9	Pull-up	1
GPIO15	Floating	–

To change the bit values, the strapping pins should be connected to external pull-down/pull-up resistances. If the ESP32-C6 is used as a device by a host MCU, the strapping pin voltage levels can also be controlled by the host MCU.

All strapping pins have latches. At system reset, the latches sample the bit values of their respective strapping pins and store them until the chip is powered down or shut down. The states of latches cannot be changed in any other way. It makes the strapping pin values available during the entire chip operation, and the pins are freed up to be used as regular IOs after reset.

3.3.1 SDIO Sampling and Driving Clock Edge Control

The strapping pin MTMS and MTDI can be used to decide on which clock edge to sample signals and drive output lines. See [Table 4 SDIO Sampling and Driving Clock Edge Control](#).

Table 4: SDIO Sampling and Driving Clock Edge Control

Pin	Default Value	Function
MTMS	– (Floating)	Controls the input sampling edge
MTDI	– (Floating)	Controls the output driving edge

3.3.2 Chip Boot Mode Control

GPIO8 and GPIO9 control the boot mode after the reset is released. See [Table 5 Boot Mode Control](#).

Table 5: Boot Mode Control

Boot Mode	GPIO8	GPIO9
Default Config	– (Floating)	1 (Pull-up)
SPI Boot	Any value	1
Download Boot	1	0
Invalid combination ¹	0	0

¹ This combination triggers unexpected behavior and should be avoided.

3.3.3 ROM Code Printing Control

During boot process the output log by the ROM code can be printed:

- To **USB Serial/JTAG controller**. For this, set EFUSE_DIS_USB_DEVICE to 0.
- To **UART**. For this, set EFUSE_DIS_USB_DEVICE not to 0. In this case, EFUSE_UART_PRINT_CONTROL and GPIO8 control ROM code printing as shown in Table 6 ROM Code Printing Control.

Table 6: ROM Code Printing Control

eFuse ¹	GPIO8	ROM Code Printing
0	Ignored	Always enabled
1	0	Enabled
	1	Disabled
2	0	Disabled
	1	Enabled
3	Ignored	Always disabled

¹ eFuse: EFUSE_UART_PRINT_CONTROL

3.3.4 JTAG Signal Source Control

The strapping pin GPIO15 can be used to control the source of JTAG signals during the early boot process. This pin does not have any internal pull resistors and the strapping value must be controlled by the external circuit that cannot be in a high impedance state.

As Table 7 shows, GPIO15 is used in combination with EFUSE_DIS_PAD_JTAG, EFUSE_DIS_USB_JTAG, and EFUSE_STRAP_JTAG_SEL.

Table 7: JTAG Signal Source Control

eFuse 1 ^a	eFuse 2 ^b	eFuse 3 ^c	GPIO15	JTAG Signal Source
0	0	0	Ignored	USB Serial/JTAG Controller
		1	0	JTAG pins MTDI, MTCK, MTMS, and MTDO
			1	USB Serial/JTAG Controller
0	1	Ignored	Ignored	JTAG pins MTDI, MTCK, MTMS, and MTDO
1	0	Ignored	Ignored	USB Serial/JTAG Controller
1	1	Ignored	Ignored	JTAG is disabled

^a eFuse 1: EFUSE_DIS_PAD_JTAG

^b eFuse 2: EFUSE_DIS_USB_JTAG

^c eFuse 3: EFUSE_STRAP_JTAG_SEL

4 Electrical Characteristics

The values presented in this section are preliminary and may change with the final release of this datasheet.

4.1 Absolute Maximum Ratings

Stresses above those listed in Table 8 *Absolute Maximum Ratings* may cause permanent damage to the device. These are stress ratings only and functional operation of the device at these or any other conditions beyond those indicated under Table 9 *Recommended Operating Conditions* is not implied. Exposure to absolute-maximum-rated conditions for extended periods may affect device reliability.

Table 8: Absolute Maximum Ratings

Symbol	Parameter	Min	Max	Unit
VDD33	Power supply voltage	-0.3	3.6	V
T _{STORE}	Storage temperature	-40	105	°C

4.2 Recommended Operating Conditions

Table 9: Recommended Operating Conditions

Symbol	Parameter	Min	Typ	Max	Unit
VDD33	Power supply voltage	3.0	3.3	3.6	V
I _{VDD}	Current delivered by external power supply	0.5	—	—	A
T _A	Operating ambient temperature	-40	—	85	°C
				105	

4.3 DC Characteristics (3.3 V, 25 °C)

Table 10: DC Characteristics (3.3 V, 25 °C)

Symbol	Parameter	Min	Typ	Max	Unit
C _{IN}	Pin capacitance	—	2	—	pF
V _{IH}	High-level input voltage	0.75 × VDD ¹	—	VDD ¹ + 0.3	V
V _{IL}	Low-level input voltage	-0.3	—	0.25 × VDD ¹	V
I _{IH}	High-level input current	—	—	50	nA
I _{IL}	Low-level input current	—	—	50	nA
V _{OH} ²	High-level output voltage	0.8 × VDD ¹	—	—	V
V _{OL} ²	Low-level output voltage	—	—	0.1 × VDD ¹	V
I _{OH}	High-level source current (VDD ¹ = 3.3 V, V _{OH} ≥ 2.64 V, PAD_DRIVER = 3)	—	40	—	mA
I _{OL}	Low-level sink current (VDD ¹ = 3.3 V, V _{OL} = 0.495 V, PAD_DRIVER = 3)	—	28	—	mA
R _{PU}	Pull-up resistor	—	45	—	kΩ

R_{PD}	Pull-down resistor	—	45	—	$k\Omega$
V_{IH_nRST}	Chip reset release voltage	$0.75 \times VDD^1$	—	$VDD^1 + 0.3$	V
V_{IL_nRST}	Chip reset voltage	-0.3	—	$0.25 \times VDD^1$	V

¹ VDD is the I/O voltage for pins of a particular power domain.

² V_{OH} and V_{OL} are measured using high-impedance load.

PRELIMINARY

5 Module Schematics

This is the reference design of the module.

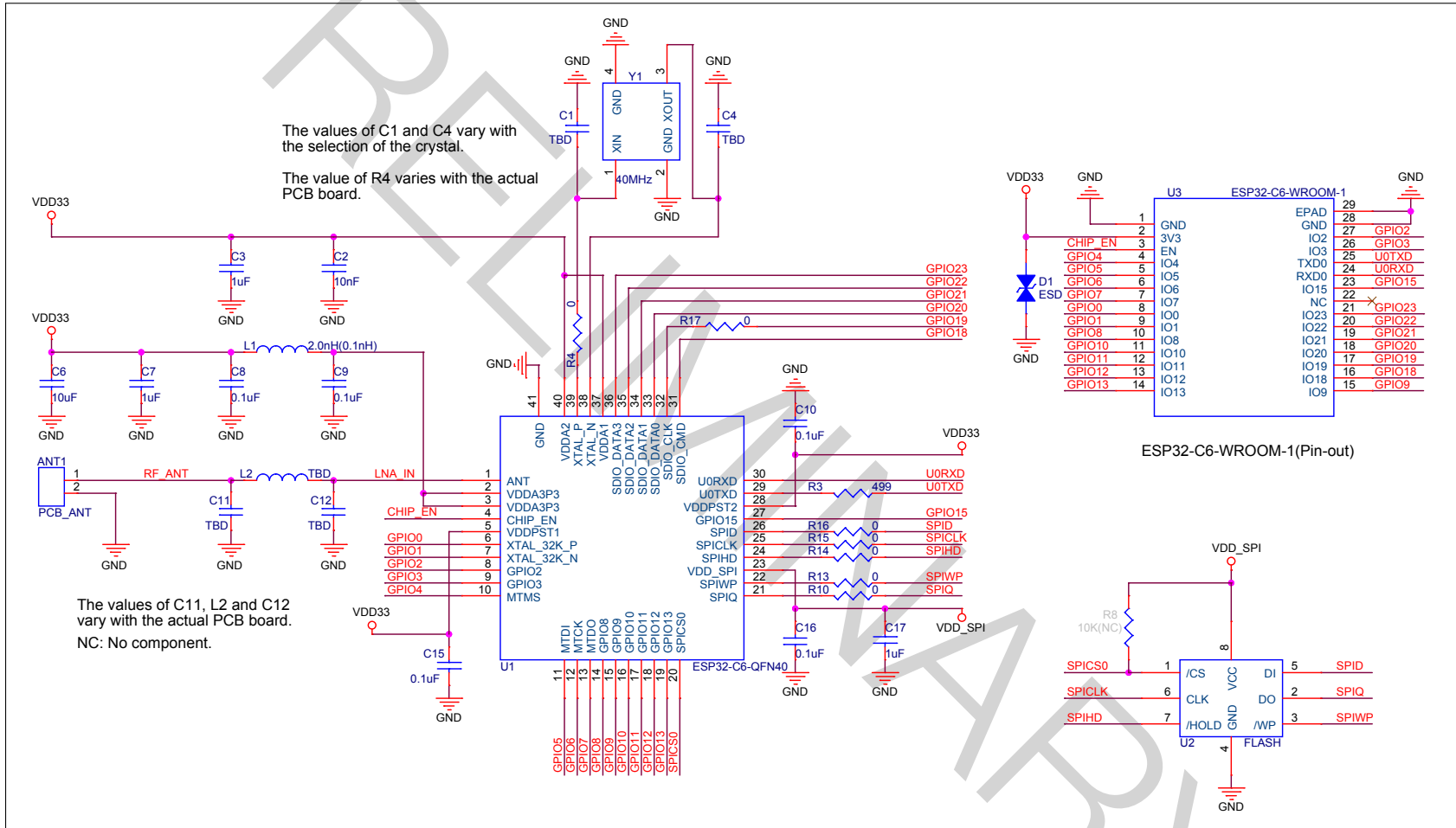

Figure 3: ESP32-C6-WROOM-1 Schematics

6 Peripheral Schematics

This is the typical application circuit of the module connected with peripheral components (for example, power supply, antenna, reset button, JTAG interface, and UART interface).

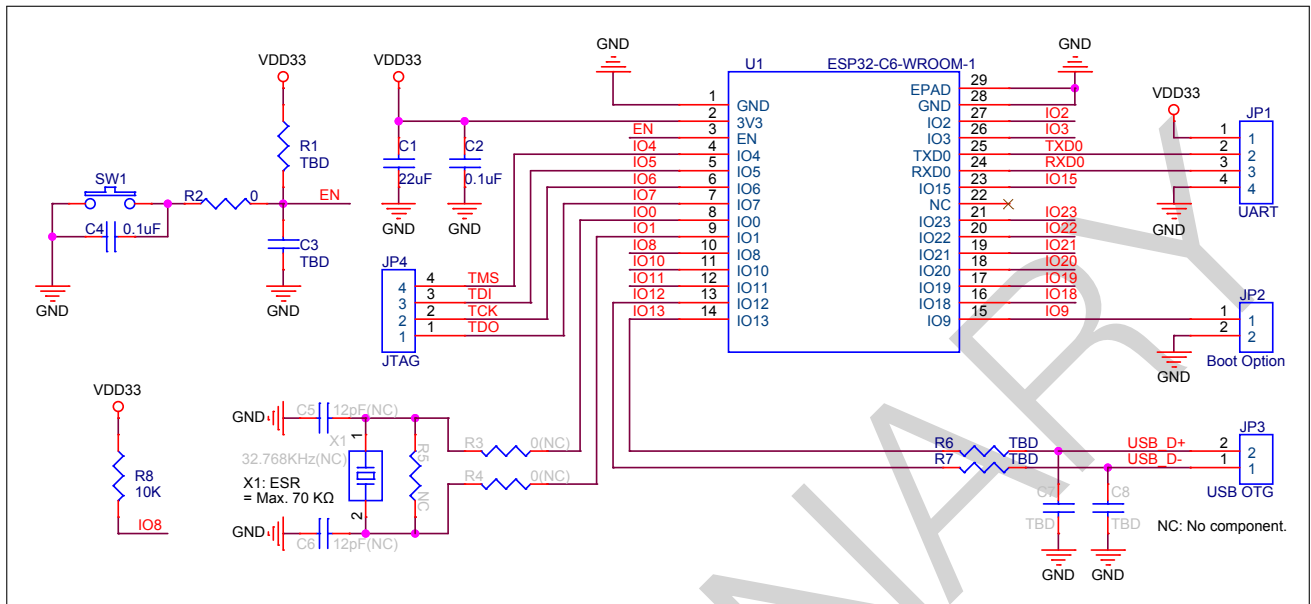

Figure 4: Peripheral Schematics

- Soldering the EPAD to the ground of the base board is not a must, however, it can optimize thermal performance. If you choose to solder it, please apply the correct amount of soldering paste.
- To ensure that the power supply to the ESP32-C6 chip is stable during power-up, it is advised to add an RC delay circuit at the EN pin. The recommended setting for the RC delay circuit is usually $R = 10\text{ k}\Omega$ and $C = 1\ \mu\text{F}$. However, specific parameters should be adjusted based on the power-up timing of the module and the power-up and reset sequence timing of the chip. For ESP32-C6's power-up and reset sequence timing diagram, please refer to *ESP32-C6 Series Datasheet > Section Power Supply*.

7 Physical Dimensions and PCB Land Pattern

7.1 Physical Dimensions

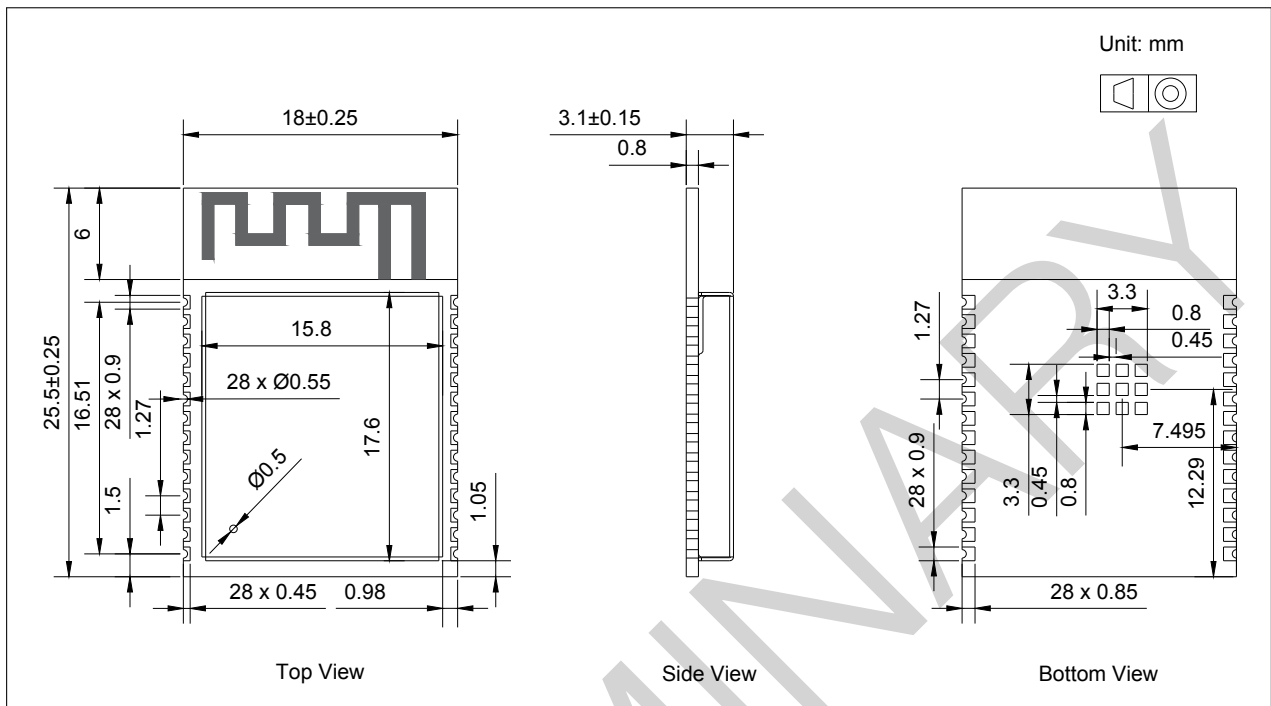

Figure 5: Physical Dimensions

Note:

For information about tape, reel, and product marking, please refer to [Espressif Module Packaging Information](#).

7.2 Recommended PCB Land Pattern

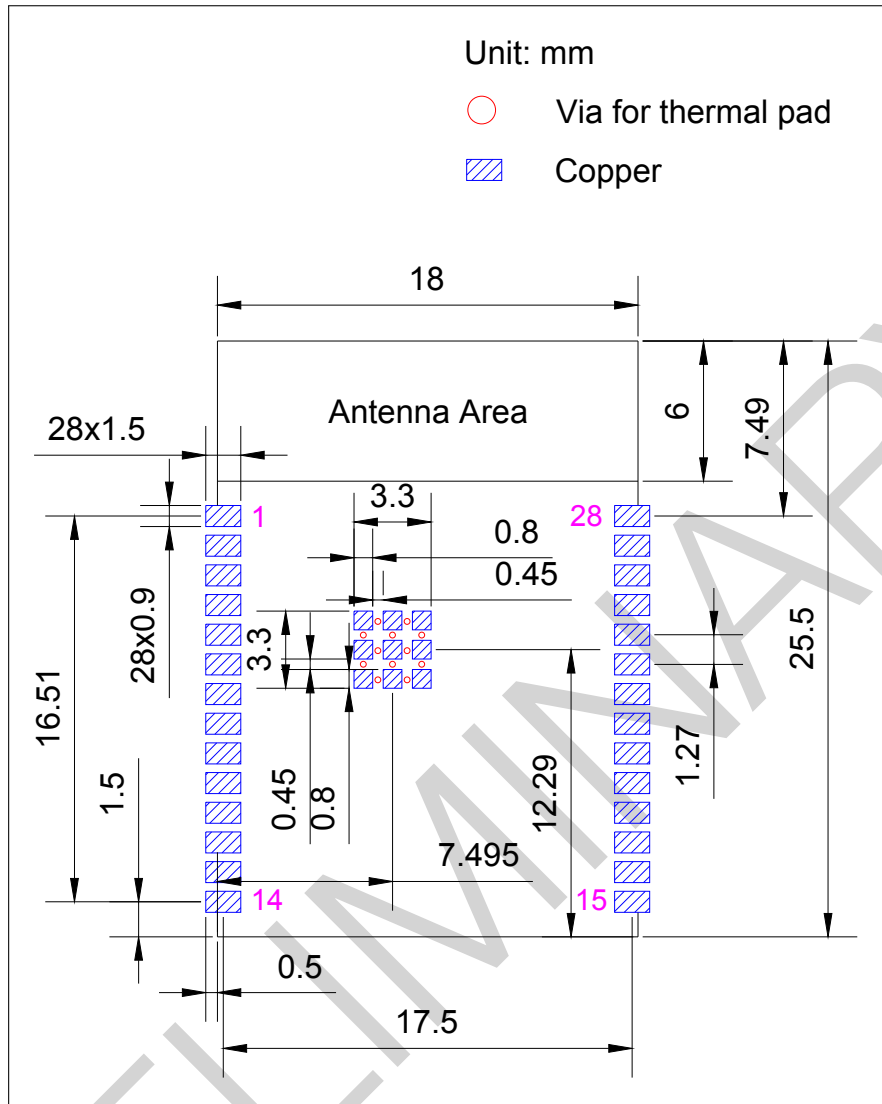

Figure 6: Recommended PCB Land Pattern

8 Product Handling

8.1 Storage Conditions

The products sealed in moisture barrier bags (MBB) should be stored in a non-condensing atmospheric environment of $< 40\text{ }^{\circ}\text{C}$ and 90%RH. The module is rated at the moisture sensitivity level (MSL) of 3.

After unpacking, the module must be soldered within 168 hours with the factory conditions $25\pm 5\text{ }^{\circ}\text{C}$ and 60%RH. If the above conditions are not met, the module needs to be baked.

8.2 Electrostatic Discharge (ESD)

- Human body model (HBM): $\pm 2000\text{ V}$
- Charged-device model (CDM): $\pm 500\text{ V}$

8.3 Soldering Profile

8.3.1 Reflow Profile

Solder the module in a single reflow.

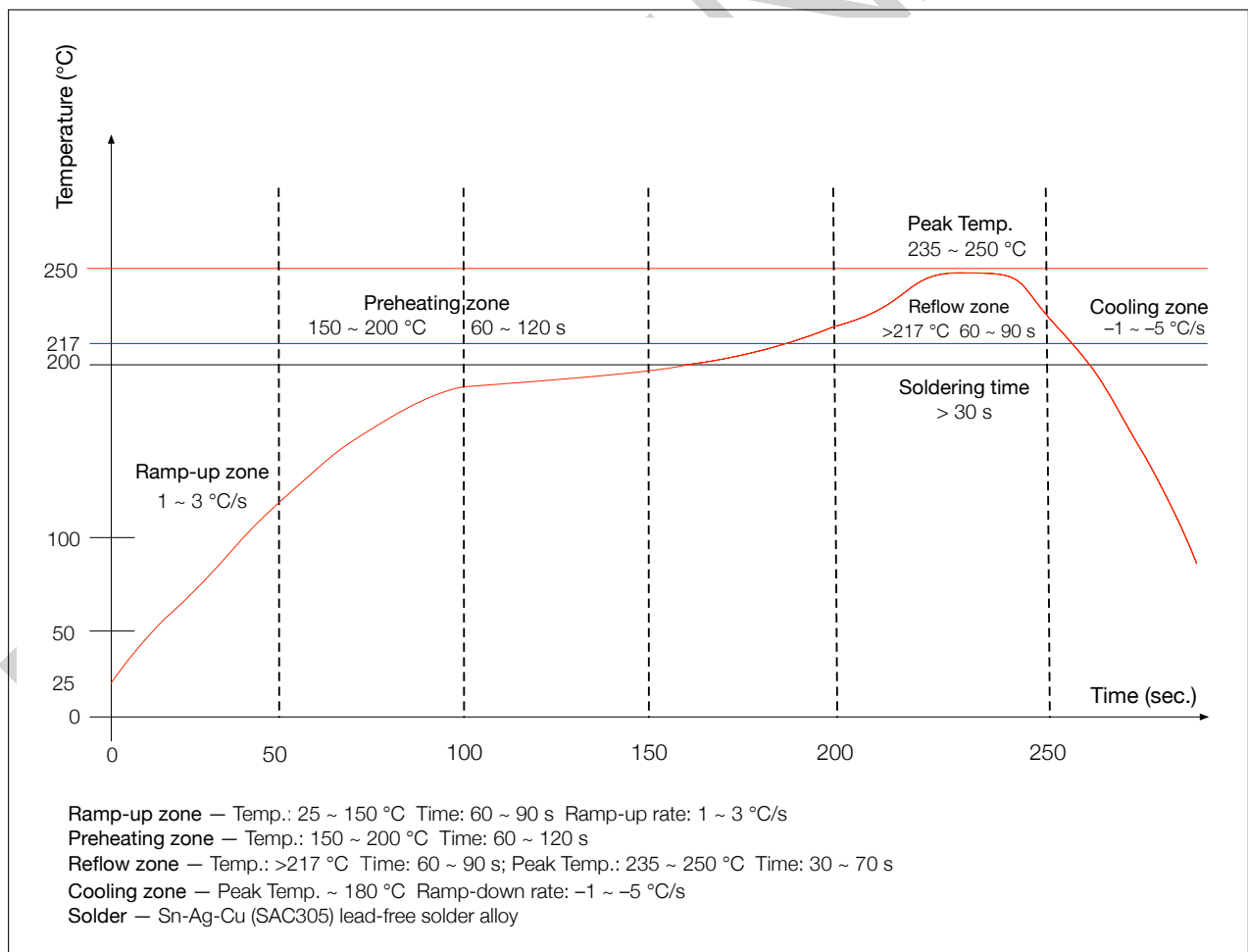

Figure 7: Reflow Profile

8.4 Ultrasonic Vibration

Avoid exposing Espressif modules to vibration from ultrasonic equipment, such as ultrasonic welders or ultrasonic cleaners. This vibration may induce resonance in the in-module crystal and lead to its malfunction or even failure. As a consequence, **the module may stop working or its performance may deteriorate.**

PRELIMINARY

9 Related Documentation and Resources

Related Documentation

- *Certificates*
<https://espressif.com/en/support/documents/certificates>
- *Documentation Updates and Update Notification Subscription*
<https://espressif.com/en/support/download/documents>

Developer Zone

- *ESP-IDF* and other development frameworks on GitHub.
<https://github.com/espressif>
- *ESP32 BBS Forum* – Engineer-to-Engineer (E2E) Community for Espressif products where you can post questions, share knowledge, explore ideas, and help solve problems with fellow engineers.
<https://esp32.com/>
- *The ESP Journal* – Best Practices, Articles, and Notes from Espressif folks.
<https://blog.espressif.com/>
- See the tabs *SDKs and Demos, Apps, Tools, AT Firmware*.
<https://espressif.com/en/support/download/sdks-demos>

Products

- *ESP32-C6 Series SoCs* – Browse through all ESP32-C6 SoCs.
<https://espressif.com/en/products/socs?id=ESP32-C6>
- *ESP32-C6 Series Modules* – Browse through all ESP32-C6-based modules.
<https://espressif.com/en/products/modules?id=ESP32-C6>
- *ESP32-C6 Series DevKits* – Browse through all ESP32-C6-based devkits.
<https://espressif.com/en/products/devkits?id=ESP32-C6>
- *ESP Product Selector* – Find an Espressif hardware product suitable for your needs by comparing or applying filters.
<https://products.espressif.com/#/product-selector?language=en>

Contact Us

- See the tabs *Sales Questions, Technical Enquiries, Circuit Schematic & PCB Design Review, Get Samples (Online stores), Become Our Supplier, Comments & Suggestions*.
<https://espressif.com/en/contact-us/sales-questions>

Revision History

Date	Version	Release notes
2022-12-xx	v0.1	Preliminary release

PRELIMINARY

PRELIMINARY



www.espressif.com

Disclaimer and Copyright Notice

Information in this document, including URL references, is subject to change without notice.

ALL THIRD PARTY'S INFORMATION IN THIS DOCUMENT IS PROVIDED AS IS WITH NO WARRANTIES TO ITS AUTHENTICITY AND ACCURACY.

NO WARRANTY IS PROVIDED TO THIS DOCUMENT FOR ITS MERCHANTABILITY, NON-INFRINGEMENT, FITNESS FOR ANY PARTICULAR PURPOSE, NOR DOES ANY WARRANTY OTHERWISE ARISING OUT OF ANY PROPOSAL, SPECIFICATION OR SAMPLE.

All liability, including liability for infringement of any proprietary rights, relating to use of information in this document is disclaimed. No licenses express or implied, by estoppel or otherwise, to any intellectual property rights are granted herein.

The Wi-Fi Alliance Member logo is a trademark of the Wi-Fi Alliance. The Bluetooth logo is a registered trademark of Bluetooth SIG.

All trade names, trademarks and registered trademarks mentioned in this document are property of their respective owners, and are hereby acknowledged.

Copyright © 2022 Espressif Systems (Shanghai) Co., Ltd. All rights reserved.

Mouser Electronics

Authorized Distributor

Click to View Pricing, Inventory, Delivery & Lifecycle Information:

[Espressif:](#)

[ESP32-C6-WROOM-1-N4](#) [ESP32-C6-WROOM-1-N8](#)