

FTDI Chip

VM801P Datasheet

Embedded Video Engine Plus Module



General Purpose Multi Media Controller

The VM801P is a development module for FTDI's FT801, which is used to develop and demonstrate the functionality of the FT801 Embedded Video Engine, EVE. The VM801P is a stand-alone display system which has a flash based microcontroller on board, thus providing a fully integrated display system ready to go.

The VM801P supports many I/O daughter cards or shields for expanding external interfacing and control. These shields use 1 or 2 Micro-MaTch miniature connectors to interface to the VM801P main module. Users will be able to purchase shields from FTDI Chip in the coming months, or alternatively can build their own shield for specific applications.

The VM801P series of modules support 2 different LCD panel size options and are designed for industrial or commercial environments with precision fitted bezels in either black (-BK) or pearl (-PL).

- VM801P43A-xx is the 4.3" LCD
- VM801P50A-xx is the 5.0" LCD

The VM801P utilises the FTDI FT801 Embedded Video Engine, EVE. Graphic, audio and capacitive touch features of the FT801 chip can be accessed with the VM801P. For a full list of the FT801's features please see the FT801 datasheet.

The VM801P module has the following features:

- FT801 for graphics, audio and touch processing
- ATMEGA328P system microcontroller operating at 5V/16MHz supporting Arduino libraries
- 5 point Capacitive Touch screen LCD panel
- Backlight LED driver
- Audio power amplifier and micro speaker
- FT232R USB serial port for firmware upgrade
- Micro-SD socket for application storage, including 4GByte SD Card pre-loaded with sample applications
- Battery backed Real Time Clock
- 2x Micro-MaTch miniature connectors for daughter card expansion
- 5V power supply from micro-USB or battery connector
- Precision fitted bezel in black(-BK) or pearl (-PL)

Neither the whole nor any part of the information contained in, or the product described in this manual, may be adapted or reproduced in any material or electronic form without the prior written consent of the copyright holder. This product and its documentation are supplied on an as-is basis and no warranty as to their suitability for any particular purpose is either made or implied. Future Technology Devices International Ltd will not accept any claim for damages howsoever arising as a result of use or failure of this product. Your statutory rights are not affected. This product or any variant of it is not intended for use in any medical appliance, device or system in which the failure of the product might reasonably be expected to result in personal injury. This document provides preliminary information that may be subject to change without notice. No freedom to use patents or other intellectual property rights is implied by the publication of this document. Future Technology Devices International Ltd, Unit 1, 2 Seaward Place, Centurion Business Park, Glasgow G41 1HH United Kingdom. Scotland Registered Company Number: SC136640

1 Ordering Information

Part No.	Description
VM801P43A-BK	FT801 Display System, ATMEG328P @ 5V/16MHz, Micro-SD socket, 4.3" 480x272 resolution TFT LCD with capacitive touch panel, black case
VM801P50A-BK	FT801 Display System, ATMEG328P @ 5V/16MHz, Micro-SD socket, 5.0" 480x272 resolution TFT LCD with capacitive touch panel, black case
VM801P43A-PL	FT801 Display System, ATMEG328P @ 5V/16MHz, Micro-SD socket, 4.3" 480x272 resolution TFT LCD with capacitive touch panel, pearl case
VM801P50A-PL	FT801 Display System, ATMEG328P @ 5V/16MHz, Micro-SD socket, 5.0" 480x272 resolution TFT LCD with capacitive touch panel, pearl case
ACCESSORIES	
VA800A-PROG	Accessory - PLUS Production Programmer for ATMEGA328P inc Tag Connect TC2030-IDC-FP cable
VA-PSU-UK1	Accessory - UK Model 5V/1A USB Power Supply (Mfr # JX-B0520C-1-B)
VA-PSU-US1	Accessory - US Model 5V/1A USB Power Supply (Mfr # JX-B0520B-1-B)
VA-PSU-EU1	Accessory - EU Model 5V/1A USB Power Supply (Mfr # JX-B0520A-1-B)
VA-FC-1M-BKW	Accessory - Flat USB A to Micro B Cable 1M- Black and White
VA-FC-1M-BLW	Accessory - Flat USB A to Micro B Cable 1M- Blue and White
VI800A-TTLU	VI800A UART TTL module, plug in board to VM800P Plus module
VI800A-232U	VI800A RS232 module, plug in board to VM800P Plus module
VI800A-N485U	VI800A RS485 module, plug in board for the VM800P Plus module
VI800A-RELAY	VI800A Opto-isolated Inputs and RELAY output module, plug in board to VM800P Plus module
VI800A-ETH	VI800A Ethernet module, plug in board for the VM800P Plus module
VI800A-PoE	VI800A POE Ethernet module, plug in board for the VM800P Plus module

Table 1.1 VM801P & Accessory Ordering Information

Table of Contents

1	Ordering Information	2
2	Hardware Description	5
2.1	Physical Description	6
2.1.1	Dimensions	6
2.2	Connectors and Jumpers	6
2.2.1	CN1 - 2-pin power connector	6
2.2.2	CN2 – Micro USB Receptacle	7
2.2.3	J2 – Audio Selection	7
2.2.4	J5 – Expansion Connector for I/O Daughter Card	7
2.2.5	J6 - Expansion Connector for Comm Daughter Card	8
2.2.6	JP1 – Audio Amplifier Power Selection	9
2.2.7	SW1 – 5V Power Source Selection.....	9
2.2.8	JP4 – USB Power Selection.....	9
2.3	Board Schematics.....	10
3	Hardware Setup Guide.....	14
3.1	Power Configuration.....	14
4	Arduino® Setup	15
4.1	Hardware Setup	15
4.2	Software Setup.....	15
5	Assembling the Bezel and Panel Mounting.....	18
5.1	Dimensions for 4.3” Bezel	19
5.2	Dimensions for 5.0” Bezel	20
6	Specifications	21
6.1	LCD Optical Specifications for 4.3” Panel	21
6.2	LCD Optical Specifications for 5.0” Panel	22
7	Contact Information	23
	Appendix A – References	24

Document References	24
Acronyms and Abbreviations.....	24
Appendix B – List of Tables & Figures	25
List of Tables.....	25
List of Figures	25
Appendix C – Revision History	26

2 Hardware Description



Figure 2-1 VM801P43A/VM801P50A Module Top and Bottom View

NOTE: The above modules are also available with pearl colored bezels.

The VM801P module is available for different LCD sizes: 4.3" or 5".

Each VM801P module is assembled with the following parts:

- HW_362_VM801P PCB board
- LCD panel with capacitive touch screen
- Bezel

The main functions of the VM801PxxA module are as follows:

- FT801 EVE for graphic, audio and capacitive touch control
- ATMEGA328P microcontroller operating at 5V and 16MHz, controlling the FT801 and other peripheral interfaces
- 3 stage audio filter
- 8Ω micro speaker to work with on-board audio amplifier
- Jumper selection allowing audio line out option
- LCD backlight LED driver
- Real Time Clock(RTC) with button battery
- USB interface for power supply and firmware programming
- 2-pin JST connector for alternative power source
- 3.3V regulator: takes 5V input and outputs 3.3V for on-board circuits
- 2x Micro-MaTch miniature connectors for various daughter card expansion
- SD Card Socket (4GByte card supplied with module)

2.1 Physical Description

The VM801P module dimensions are illustrated in Error! Reference source not found. **Figure 2-2**.

2.1.1 Dimensions

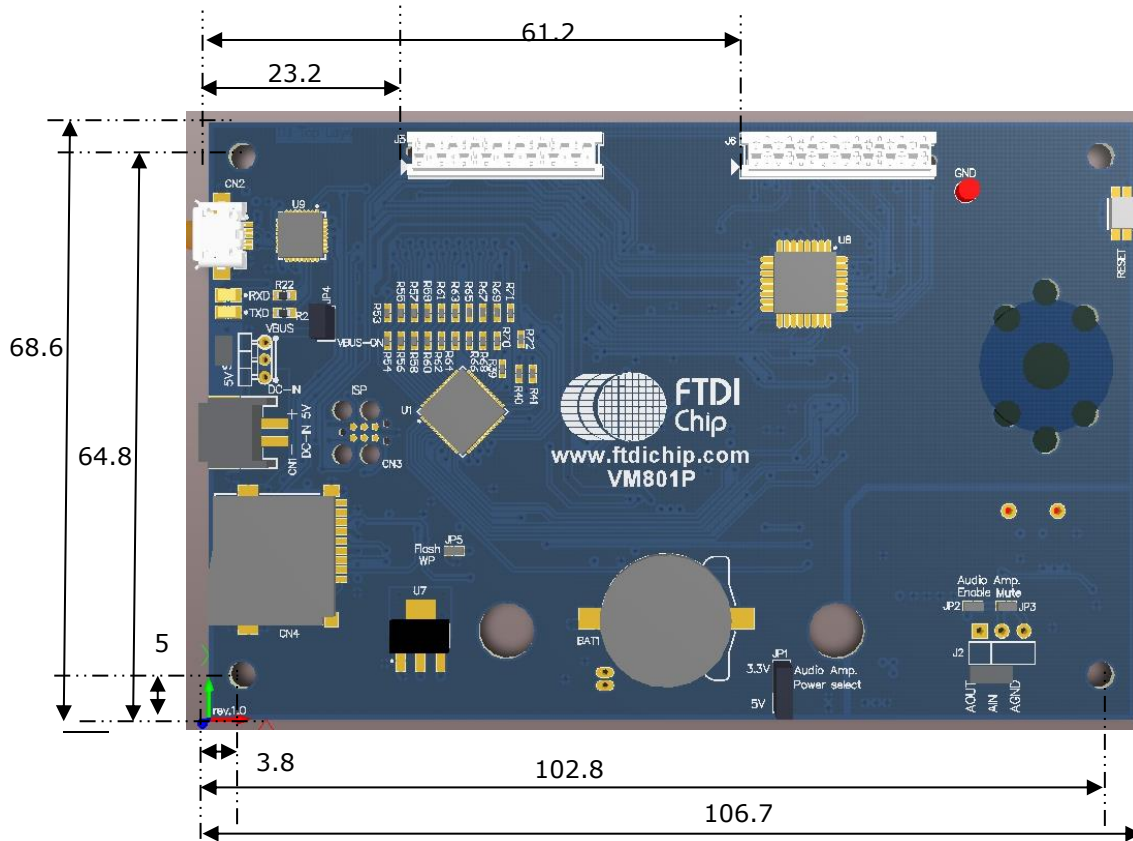

Figure 2-2 VM801P43A/VM801P50A Dimensions (Top view)

±0.50mm Tolerance

All dimensions are in mm

2.2 Connectors and Jumpers

Connectors and jumpers are described in the following sections.

2.2.1 CN1 - 2-pin power connector

Pin No.	Name	Type	Description
1	VCC	P	5V DC power supply
2	GND	P	Ground

Table 2.1 CN1 - Power Pin-out

2.2.2 CN2 – Micro USB Receptacle

Pin No.	Name	Type	Description
1	VBUS	P	5V power supply
2	D-	IO	USB D- line
3	D+	IO	USB D+ line
4	NC	NA	No connection
5	GND	P	Ground

Table 2.2 CN2 – Micro USB Pin-out

2.2.3 J2 – Audio Selection

Select between audio line-out or connection to the power amplifier.

Jumper position	Description
Short pin 1-2	Audio amp enabled (default)
Short pin 2-3	Audio amp mute, Audio lineout on pin 1

Table 2.3 J2 – Audio Options

2.2.4 J5 – Expansion Connector for I/O Daughter Card

This 16-pin Micro-MaTch miniature connector provides ATmega328P SPI/I²C/IO control to a daughter card. 5V and 3.3V power supplies are also available.

Pin No.	Name	Type	Description
1	SCK	O	SPI Clock output
2	MOSI	O	SPI Master Out Slave in
3	MISO	I	SPI Master In Slave out
4	IO7	O	SPI slave select
5	INT0	I	Interrupt input from DC
6	IO6	O	Active LOW reset output to DC
7	AD4	IO	I ² C SDA data input/output
8	AD5	O	I ² C SCL clock output
9	3V3	P	3.3V power supply to DC

Pin No.	Name	Type	Description
10	5V	P	5V power supply to DC
11	GND	P	Ground
12	RST#	O	System reset output
13	IO5	IO	GPIO
14	AD0	IO	GPIO
15	AD7	AI	ADC input
16	AD6	AI	ADC input

Table 2.4 J5 - I/O Expansion Connector Pin-out

2.2.5 J6 - Expansion Connector for Comm Daughter Card

This 16-pin Micro MaTch Miniature connector provides ATmega328P SPI/I²C/IO control to the daughter card. 5V and 3.3V power supplies are also available.

Pin No.	Name	Type	Description
1	SCK	O	SPI Clock output
2	MOSI	O	SPI Master Out Slave in
3	MISO	I	SPI Master In Slave out
4	SS	O	SPI salve select
5	INT0	I	Interrupt input from DC
6	IO6	O	Active LOW reset output to DC
7	AD4	IO	I ² C SDA data input/output
8	AD5	O	I ² C SCL clock output
9	3V3	P	3.3V power supply to DC
10	5V	P	5V power supply to DC
11	GND	P	Ground
12	RST#	O	System reset output
13	AD1	IO	GPIO
14	IO4	IO	GPIO
15	AD3	AI	GPIO
16	AD2	AI	GPIO

Table 2.5 J5 - Communication Expansion Connector Pin-out

2.2.6 JP1 – Audio Amplifier Power Selection

This jumper provides the option to select the power supply voltage for the on-board power amplifier.

Jumper position	Description
Short pin 1-2	3.3V selected (default)
Short pin 2-3	5V selected

Table 2.6 JP1 - Audio Amplifier Power Pin Options

NOTE: This needs to be configured before audio can be heard. Default is 3.3V. Select 5V to increase the maximum volume for the speaker.

2.2.7 SW1 – 5V Power Source Selection

Jumper position	Description
Short pin 1-2	Board power from CN1
Short pin 2-3	Board power from CN2 (default)

Table 2.7 SW1 - Power Source Selection

2.2.8 JP4 – USB Power Selection

Jumper position	Description
Open	Enable USB power to application circuits when FT232R is enumerated (Default). USB power will be turned off during USB suspend
Short	USB power always enabled

Table 2.8 JP4 - USB Power Selection

2.3 Board Schematics

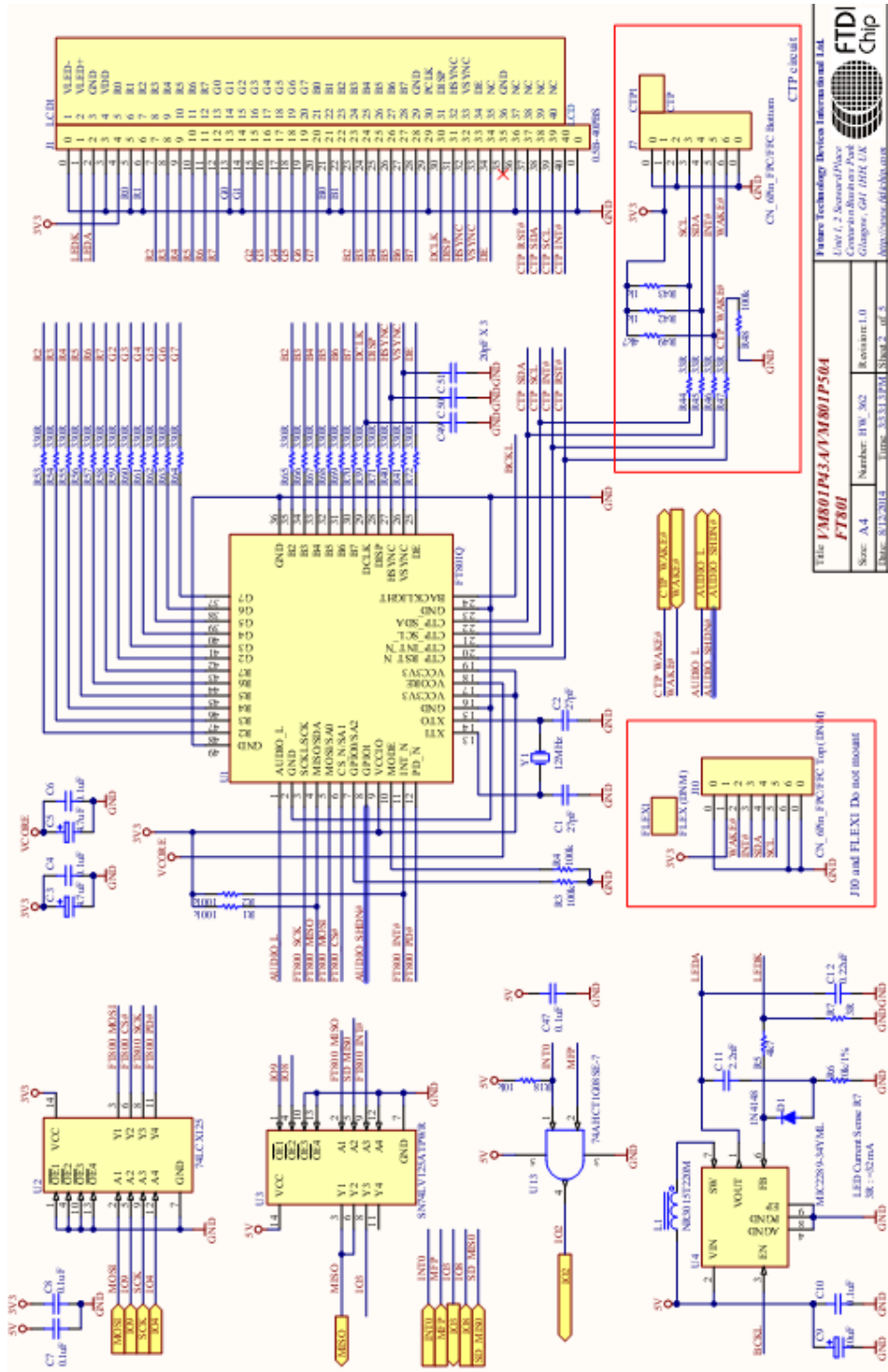

Figure 2-3 Schematics: FT801 with LED driver and LCD/CTP interface

Note: J10 is not mounted

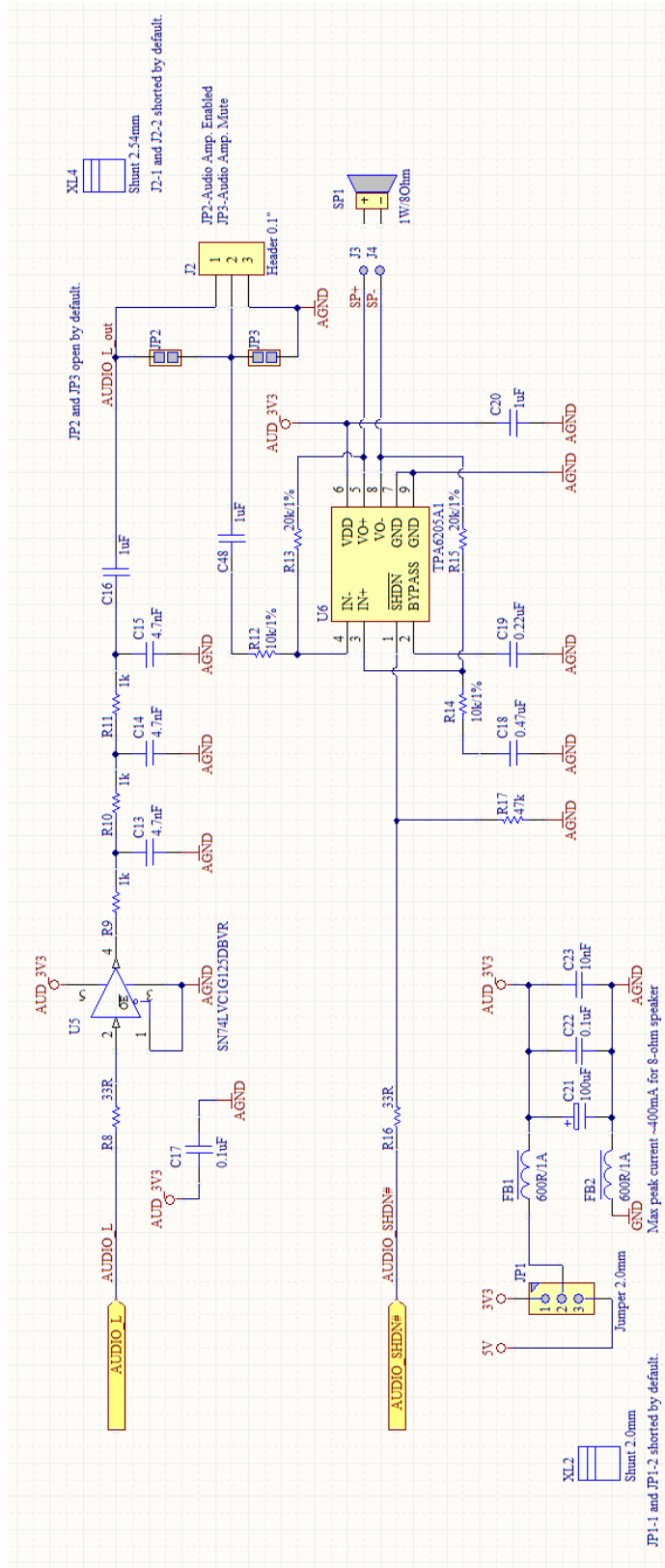
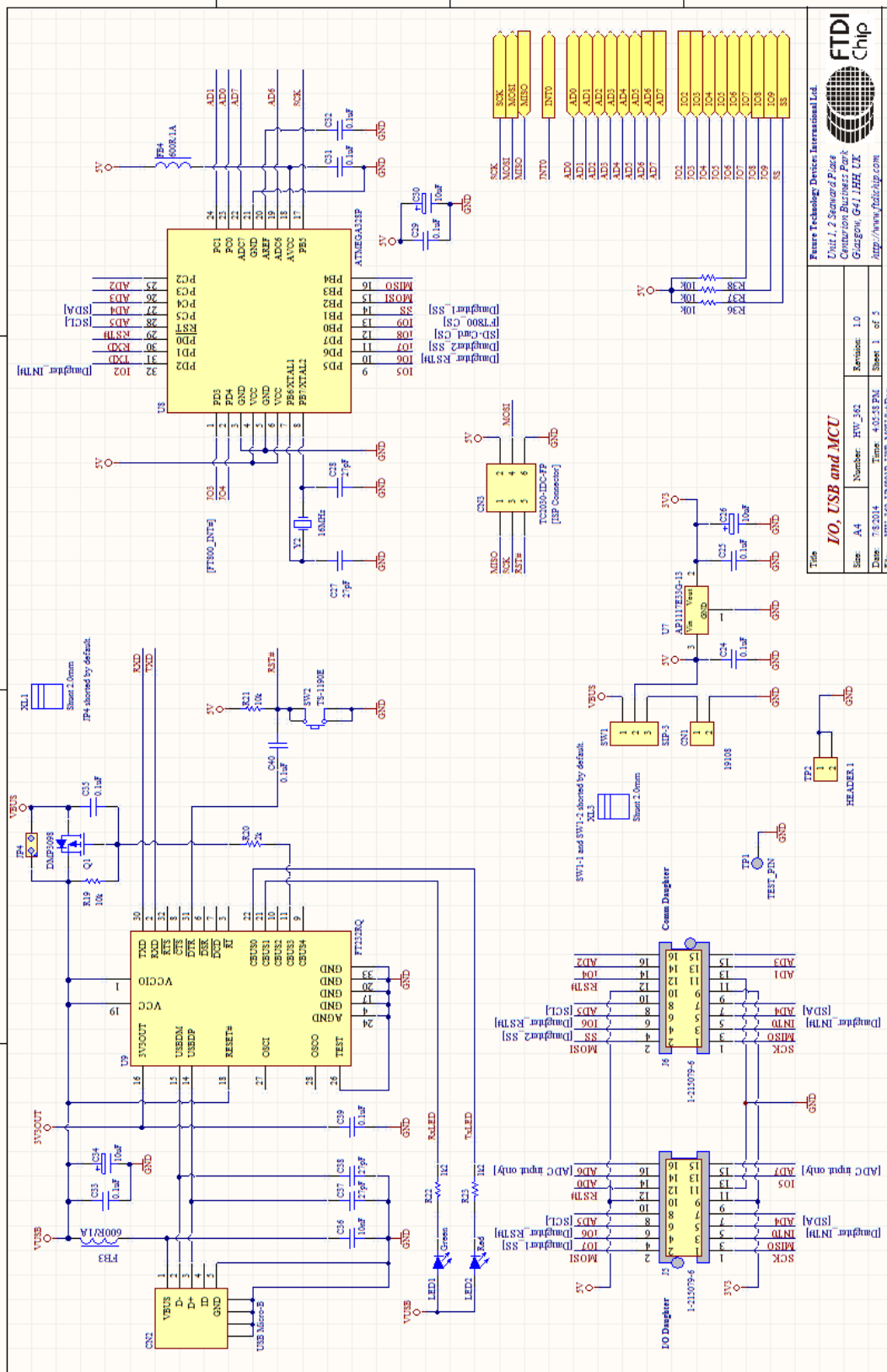

Figure 2-4 Schematics: Audio filter and amplifier



FTDI Chip

Future Technology Devices International Ltd.
 Unit 1, 2 Seward Place
 Capenhurst Business Park
 Glasgow, G4 1JH, UK
<http://www.ftdichip.com>

Title		I/O, USB and MCU	
Size:	A4	Number:	BW_362
Revision:	1.0	Sheet:	1 of 5
Date:	18/2014	Time:	4:05:53 PM
File:	BW_362_USB MCU Schem		

Figure 2-5 Schematics: ATMEGA328P with USB and I/O Connectors

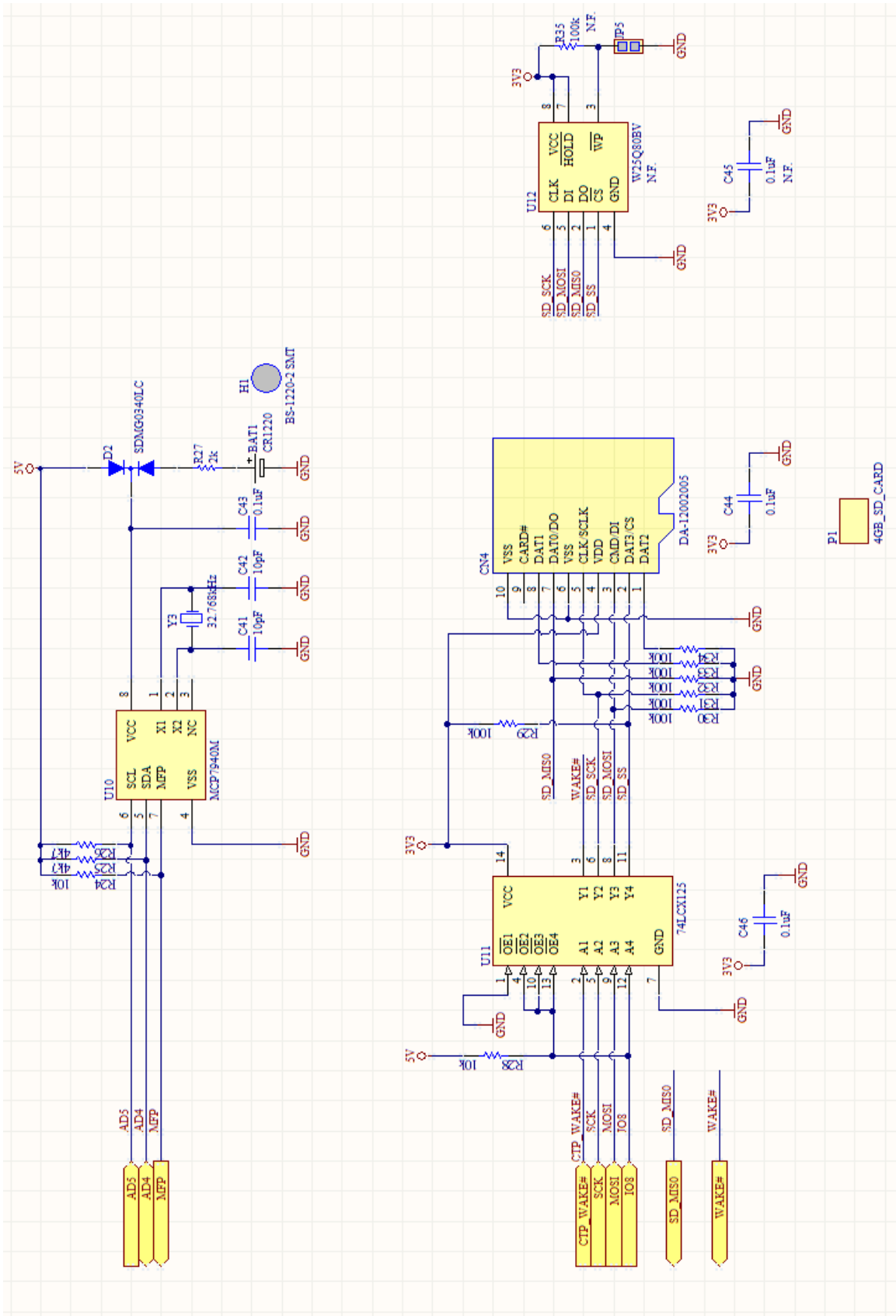

Figure 2-6 Schematics: SD socket and RTC

Note: U12 is not mounted

3 Hardware Setup Guide

3.1 Power Configuration

There are 2 methods of powering the VM801P board.

- 1) USB Power(5V) - Connect USB power through micro-USB cable to CN2
- 2) DC IN(5V) - Connect 5V to CN1

The following table summarizes how to power the VM801P board using the various methods.

Power Method	CN1	CN2	SW1
USB Power	N/C	5V	Short pin 2-3 (default)
DC IN(5V)	5V	5V	Short pin 1-2

Table 3.1 Board Power Configuration

4 Arduino® Setup

FTDI provides sample source code, sample application notes and a ready to run demo based on the Arduino® platform. Detailed information can be found at:

http://www.ftdichip.com/Support/Documents/AppNotes/AN_318_Arduino_Library_for_FT801_Series.pdf

http://www.ftdichip.com/Support/Documents/AppNotes/AN_275_FT801_Example_with_Arduino.pdf

http://www.ftdichip.com/Support/Documents/AppNotes/AN_246%20VM801CB_SampleApp_Arduino_Introduction.pdf

4.1 Hardware Setup

- Connect a USB cable (suggest FTDI accessory VA-FC-1M-BKW or VA-FC-1M-BLW) from the VM801P USB port CN2 to the PC USB host port or self-powered hub port.
- The USB will supply power to the VM801P module after the FTDI FT232R driver is properly loaded and the USB host completes USB device configuration.

4.2 Software Setup

The Arduino code can be downloaded from the Arduino IDE to the ATMEGA328P through the USB connector CN2 connected to the PC. The USB connector CN2 is also used to display debug output from the ATMEGA328P to the PC terminal application.

Default sample code is downloaded to the ATMEGA328P during the VM801P module manufacturing. When the VM801P is connected to the PC through the USB connector CN2, the VM801P is powered up and the sample code is functional with the demo applications.

- Download the Arduino IDE from <http://arduino.cc/en/main/software>.
- Install the Arduino IDE
- Open the Arduino IDE
- Open the FT801 sample project to be downloaded to the VM801P

(Examples are available from:

http://www.ftdichip.com/Support/SoftwareExamples/FT800_Projects.htm

Or you may have developed your own code)

- Select the Tools->Board-> Arduino Pro or Pro Mini(5V, 16MHz) w/ATmega328 as shown in Fig 4.1.
- Select the Tools->Serial Port->COMxx corresponding to the VM801P as shown in Fig 4.2.
- Click the Upload button as shown in Fig 4.3. This will upload the FT801 sample to the VM801P.

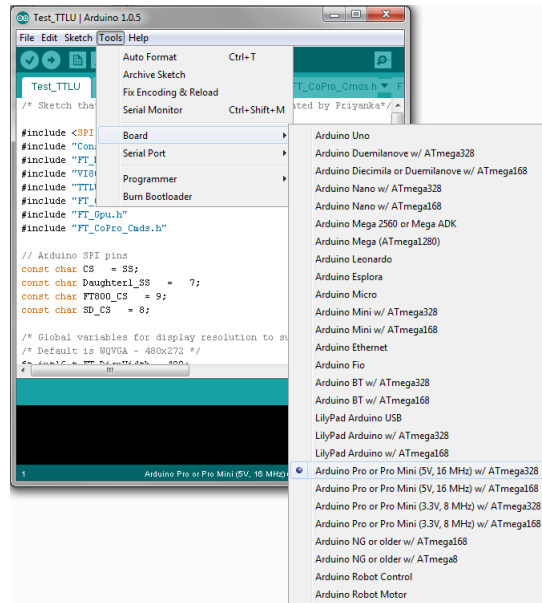

Figure 4-1 Select Board

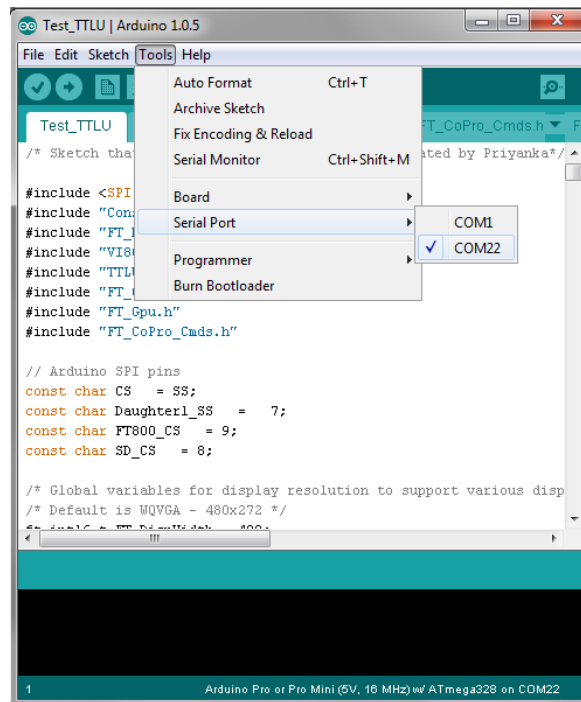

Figure 4-2 Select Serial Port

(NOTE: Your device may not be COM22 as shown. Select the COM port you have installed)

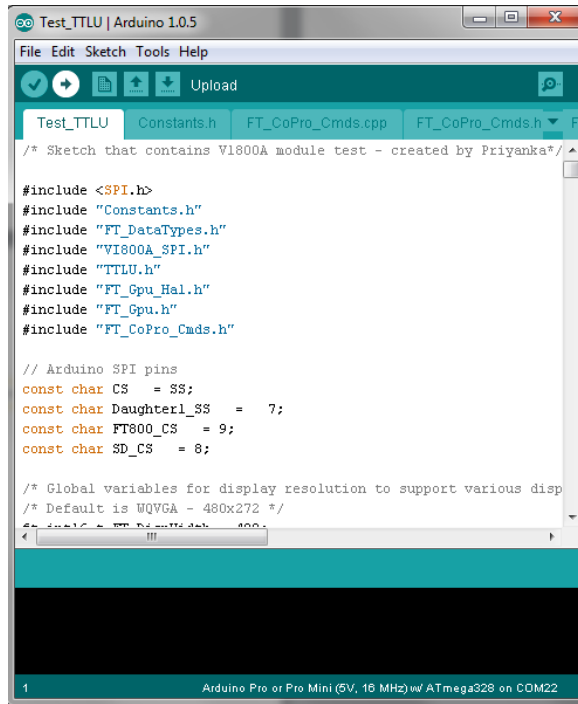

Figure 4-3 Click Upload Button

5 Assembling the Bezel and Panel Mounting

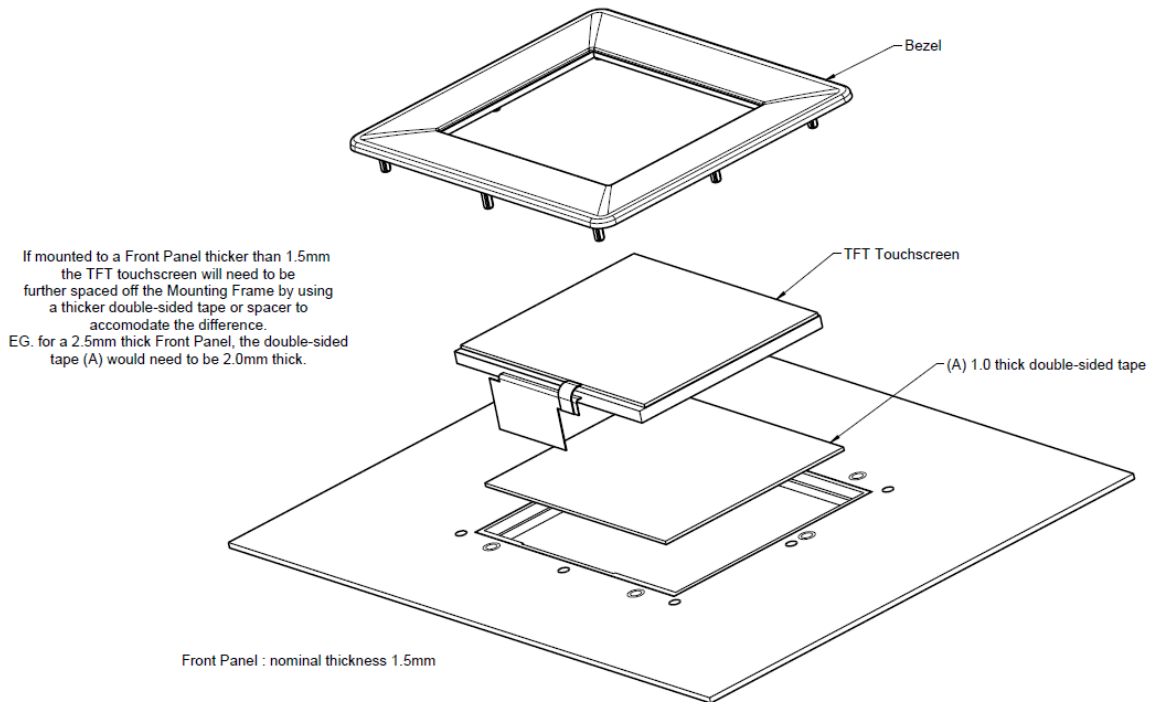

Figure 5-1 VM801P Panel Mount (Front view)

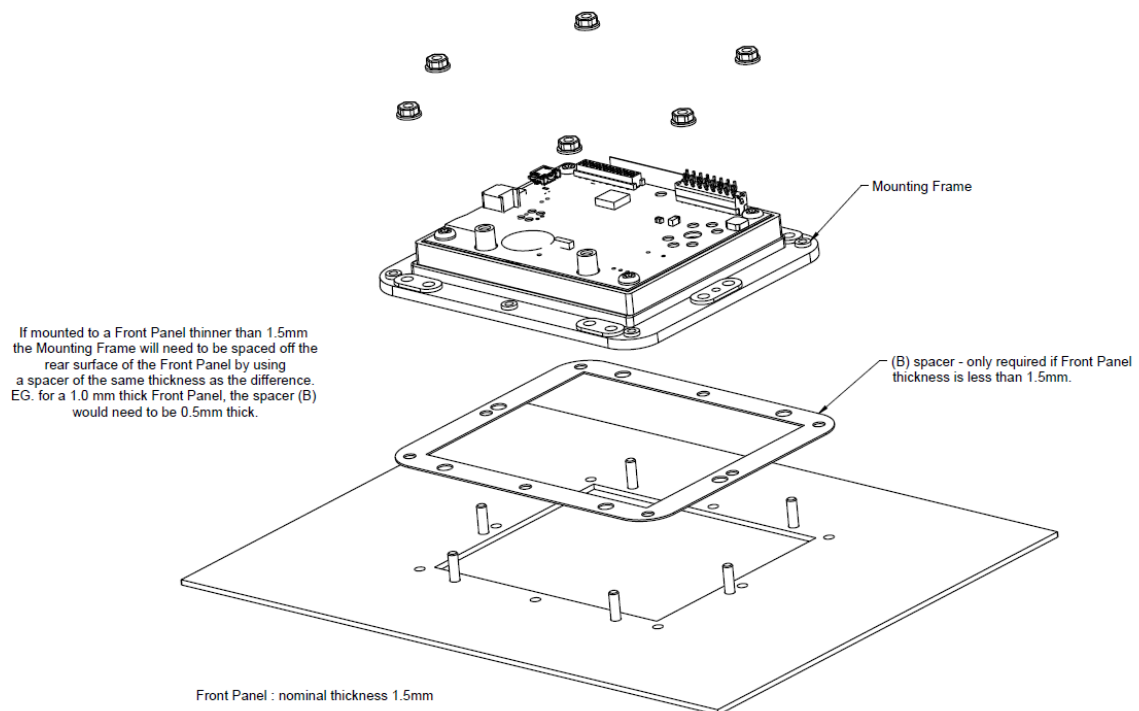

Figure 5-2 VM801P Panel Mount (Rear view)

5.1 Dimensions for 4.3" Bezel

The TFT Touchscreen Mounting Frame is designed to mount to a 1.5mm thick Front Panel. If mounted to a Front Panel thicker than 1.5mm, longer mounting studs or screws should be used to accommodate the difference.

The Mounting Frame has been designed to work with projection welded studs or csk screws 'A' or press studs 'B'. For a 1.5mm thick Front Panel use -
M3 x 8 long weld studs,
M3 x 10 long countersunk screws or
M3 x 10 long pressed studs

When using countersunk screws to assemble the Mounting Frame, the screws should be located at the 'A' position

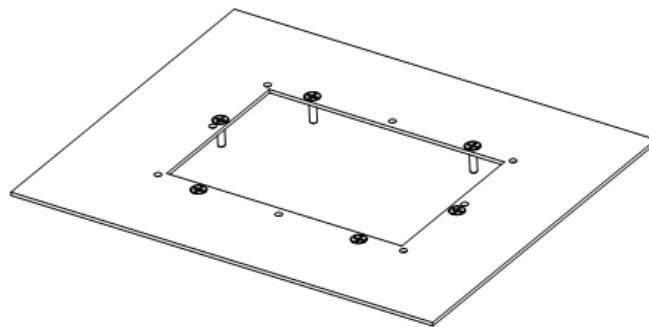
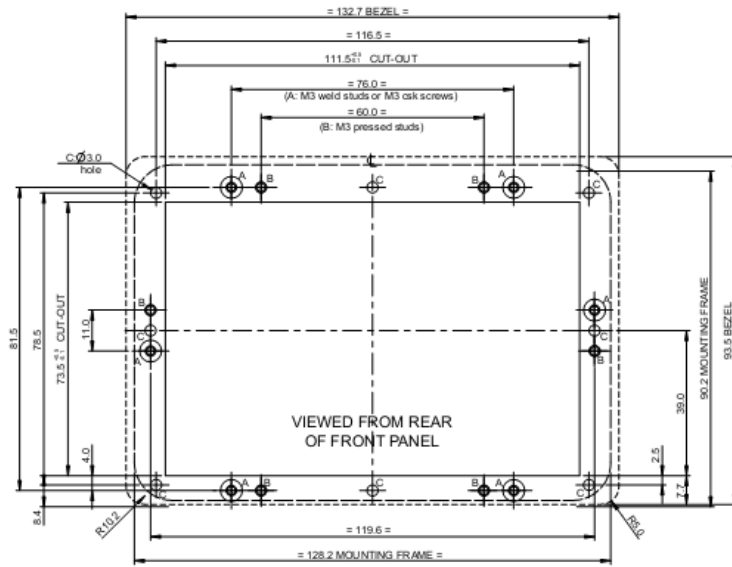

Figure 5-3 VM801P43A panel mount dimensions

5.2 Dimensions for 5.0" Bezel

The TFT Touchscreen Mounting Frame is designed to mount to a 1.5mm thick Front Panel. If mounted to a Front Panel thicker than 1.5mm, longer mounting studs or screws should be used to accommodate the difference.

The Mounting Frame has been designed to work with projection welded studs or csk screws 'A' or press studs 'B'. For a 1.5mm thick Front Panel use -
 M3 x 8 long weld studs,
 M3 x 10 long countersunk screws or
 M3 x 10 long pressed studs

When using countersunk screws to assemble the Mounting Frame, the screws should be located at the 'A' position

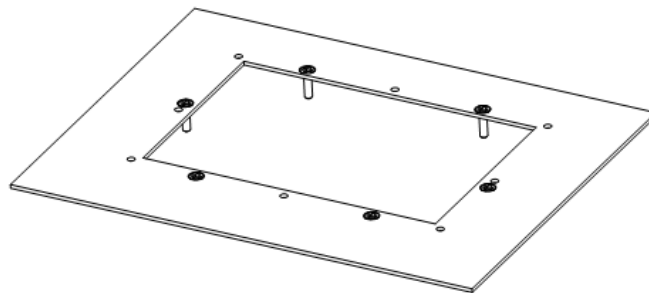
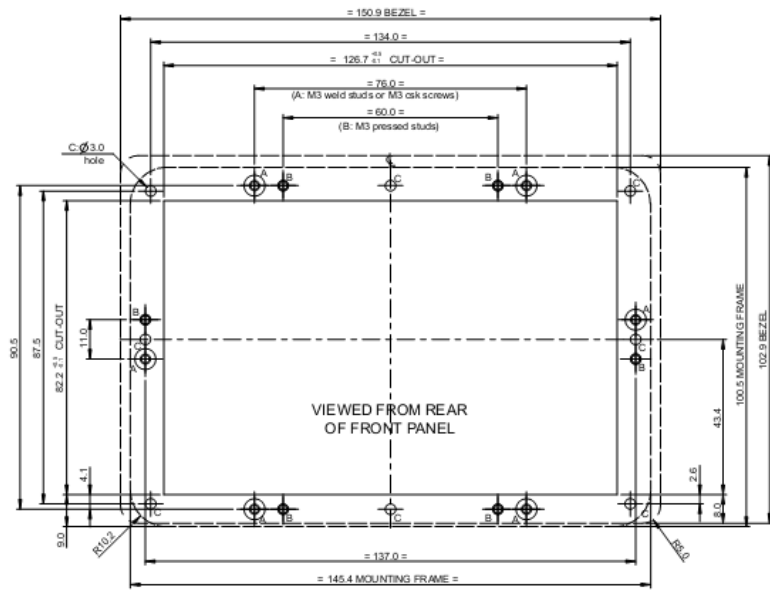

Figure 5-4 VM801P50A panel mount dimensions

6 Specifications

6.1 LCD Optical Specifications for 4.3" Panel

Item	Symbol	Condition	Min.	Typ.	Max.	Unit	Note
Brightness (With CP)	Bp	$\theta=0^\circ$ $\Phi=0^\circ$	400	450	-	Cd/m ²	1
Uniformity	Δ Bp		75	80	-	%	1,2
Viewing Angle	3:00	$Cr \geq 10$	-	60	-	Deg	3
	6:00		-	45	-		
	9:00		-	60	-		
	12:00		-	60	-		
Contrast Ratio	Cr	$\theta=0^\circ$ $\Phi=0^\circ$	300	500		-	4
Response Time	T_r	$\theta=0^\circ$ $\Phi=0^\circ$	-	10	-	ms	5
	T_f		-	10	-	ms	
Color of CIE Coordinate	W	x	$\theta=0^\circ$ $\Phi=0^\circ$	0.28		-	1,6
		y		0.33		-	
	R	x		0.51		-	
		y		0.34		-	
	G	x		0.31		-	
		y		0.56		-	
	B	x		0.15		-	
		y		0.14		-	
NTSC Ratio	S		50	60	-	%	

Note: The parameter is slightly changed by temperature, driving voltage and material

Note 1: The data are measured after LEDs are turned on for 5 minutes. LCM displays full white.

The brightness is the average value of 9 measured spots. Measurement equipment PR-705 ($\Phi 8$ mm)

Figure 6-1 4.3" TFT Optical Specifications

6.2 LCD Optical Specifications for 5.0" Panel

Item	Symbol	Condition	Min.	Typ.	Max.	Unit	Note
Brightness	Bp	$\theta=0^\circ$	200	250	-	Cd/m ²	1
Uniformity	Δ Bp	$\Phi=0^\circ$	70	80	-	%	1,2
Viewing Angle	3:00	$Cr \geq 10$	-	45	-	Deg	3
	6:00		-	25	-		
	9:00		-	45	-		
	12:00		-	45	-		
Contrast Ratio	Cr	$\theta=0^\circ$	350	500	-	-	4
Response Time	T _r	$\Phi=0^\circ$	-	10	-	ms	5
	T _f		-	10	-	ms	
Color of CIE Coordinate	W	x	$\theta=0^\circ$ $\Phi=0^\circ$	0.28	-	-	1,6
		y		0.33	-	-	
	R	x		0.51	-	-	
		y		0.34	-	-	
	G	x		0.31	-	-	
		y		0.56	-	-	
	B	x		0.15	-	-	
		y		0.14	-	-	
NTSC Ratio	S	50	60	-	%		

Note: The parameter is slightly changed by temperature, driving voltage and material

Note 1: The data are measured after LEDs are turned on for 5 minutes. LCM displays full white.

The brightness is the average value of 9 measured spots. Measurement equipment PR-705 (Φ8mm)

Figure 6-2 5.0" TFT Optical Specifications

7 Contact Information

Head Quarters – Singapore

Bridgetek Pte Ltd
178 Paya Lebar Road, #07-03
Singapore 409030
Tel: +65 6547 4827
Fax: +65 6841 6071

E-mail (Sales) sales.apac@brtchip.com
E-mail (Support) support.apac@brtchip.com

Branch Office – Taipei, Taiwan

Bridgetek Pte Ltd, Taiwan Branch
2 Floor, No. 516, Sec. 1, Nei Hu Road, Nei Hu District
Taipei 114
Taiwan, R.O.C.
Tel: +886 (2) 8797 5691
Fax: +886 (2) 8751 9737

E-mail (Sales) sales.apac@brtchip.com
E-mail (Support) support.apac@brtchip.com

Branch Office - Glasgow, United Kingdom

Bridgetek Pte. Ltd.
Unit 1, 2 Seaward Place, Centurion Business Park
Glasgow G41 1HH
United Kingdom
Tel: +44 (0) 141 429 2777
Fax: +44 (0) 141 429 2758

E-mail (Sales) sales.emea@brtchip.com
E-mail (Support) support.emea@brtchip.com

Branch Office – Vietnam

Bridgetek VietNam Company Limited
Lutaco Tower Building, 5th Floor, 173A Nguyen Van
Troï,
Ward 11, Phu Nhuan District,
Ho Chi Minh City, Vietnam
Tel : 08 38453222
Fax : 08 38455222

E-mail (Sales) sales.apac@brtchip.com
E-mail (Support) support.apac@brtchip.com

Web Site

<http://brtchip.com/>

Distributor and Sales Representatives

Please visit the Sales Network page of the [Bridgetek Web site](#) for the contact details of our distributor(s) and sales representative(s) in your country.

System and equipment manufacturers and designers are responsible to ensure that their systems, and any Future Technology Devices International Ltd (FTDI) devices incorporated in their systems, meet all applicable safety, regulatory and system-level performance requirements. All application-related information in this document (including application descriptions, suggested FTDI devices and other materials) is provided for reference only. While FTDI has taken care to assure it is accurate, this information is subject to customer confirmation, and FTDI disclaims all liability for system designs and for any applications assistance provided by FTDI. Use of FTDI devices in life support and/or safety applications is entirely at the user's risk, and the user agrees to defend, indemnify and hold harmless FTDI from any and all damages, claims, suits or expense resulting from such use. This document is subject to change without notice. No freedom to use patents or other intellectual property rights is implied by the publication of this document. Neither the whole nor any part of the information contained in, or the product described in this document, may be adapted or reproduced in any material or electronic form without the prior written consent of the copyright holder. Future Technology Devices International Ltd, Unit 1, 2 Seaward Place, Centurion Business Park, Glasgow G41 1HH, United Kingdom. Scotland Registered Company Number: SC136640

Appendix A – References

Document References

For module documentations, please refer to URL below:

<http://www.ftdichip.com/Products/modules/VM801P.html>

FT801 datasheet: [DS_FT801](#)

FT801 software programming guide: [FT800 Series Programmers Guide](#)

AN_318: [Arduino Library for FT800 Series](#)

AN_275 : [FT800 Example with Arduino](#)

AN_246: [VM800CB SampleApp Arduino Introduction](#)

AN_299: [FT800 FT801 Internal Clock Trimming](#)

AN_333: [FT800 and FT801 Touch Capabilities](#)

Acronyms and Abbreviations

Terms	Description
CTP	Capacitive Touch Panel
IO	Input Output
I ² C	Inter Integrated Circuit
LCD	Liquid Crystal Display
LED	Light-Emitting Diode
RTC	Real Time Clock
SD Card	Secure Digital Card
SPI	Serial Peripheral Interface
USB	Universal Serial Bus

Appendix B – List of Tables & Figures

List of Tables

Table 1.1 VM801P & Accessory Ordering Information.....	2
Table 2.1 CN1 - Power Pin-out.....	6
Table 2.2 CN2 – Micro USB Pin-out.....	7
Table 2.3 J2 – Audio Options	7
Table 2.4 J5 - I/O Expansion Connector Pin-out	8
Table 2.5 J5 - Communication Expansion Connector Pin-out.....	8
Table 2.6 JP1 - Audio Amplifier Power Pin Options.....	9
Table 2.7 SW1 - Power Source Selection.....	9
Table 2.8 JP4 - USB Power Selection	9
Table 3.1 Board Power Configuration	14

List of Figures

Figure 2-1 VM801P43A/VM801P50A Module Top and Bottom View	5
Figure 2-2 VM801P43A/VM801P50A Dimensions (Top view)	6
Figure 2-3 Schematics: FT801 with LED driver and LCD/CTP interface	10
Figure 2-4 Schematics: Audio filter and amplifier	11
Figure 2-5 Schematics: ATMEGA328P with USB and I0 Connectors.....	12
Figure 2-6 Schematics: SD socket and RTC	13
Figure 4-1 Select Board	16
Figure 4-2 Select Serial Port.....	16
Figure 4-3 Click Upload Button	17
Figure 5-1 VM801P Panel Mount (Front view)	18
Figure 5-2 VM801P Panel Mount (Rear view)	18
Figure 5-3 VM801P43A panel mount dimensions	19
Figure 5-4 VM801P50A panel mount dimensions	20
Figure 6-1 4.3" TFT Optical Specifications	21
Figure 6-2 5.0" TFT Optical Specifications	22

Appendix C – Revision History

Document Title: VM801P Embedded Video Engine Plus Module Datasheet
Document Reference No.: BRT_000013
Clearance No.: BRT#018
Product Page: <http://brtchip.com/product>
Document Feedback: [Send Feedback](#)

Revision	Changes	Date
1.0	First release	2014-11-25
1.1	Dual branding to reflect the migration of the product to the Bridgetek name – logo changed, copyright changed, contact information changed	2016-09-15

Mouser Electronics

Authorized Distributor

Click to View Pricing, Inventory, Delivery & Lifecycle Information:

[Bridgetek:](#)

[VM801P50A-BK](#) [VM801P43A-BK](#) [VM801P50A-PL](#) [VM801P43A-PL](#) [VM801P43A-BL](#) [VM801P50A-BL](#)