

ULTRAVOLT EFL SERIES

ENHANCED FLOATING HOT DECK LOW-VOLTAGE POWER SUPPLIES

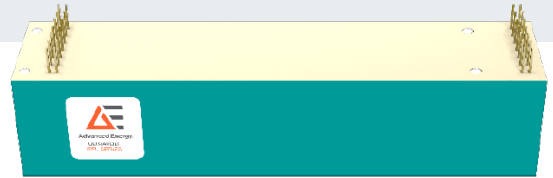

The EFL series of floating hot deck, low voltage (LV) power supplies offers an integrated solution for systems requiring LV power and controls with high voltage isolation. Combining a highly isolated, DC-to-DC, multioutput low-voltage power supply (LVPS) with an advanced isolated digital and analog I/O topology, the EFL subsystem provides both power and controls to floating-hot deck circuitry. This solution, when combined with one or more Advanced Energy high voltage power supplies or other circuitry, can provide high performance solutions for a variety of applications.

PRODUCT HIGHLIGHTS

- Precision analog control
- Linearity of $\pm 0.05\%$ and accuracy of $\pm 0.2\%$
- 10 ppm temperature coefficient
- Isolated up to 15 kV or 30 kV
- Isolation resistance of 150 G Ω (15 kV) or 2 G Ω (30 kV)
- 4 regulated floating LV power outputs
- Isolated digital and analog I/O to and from floating hot deck

TYPICAL APPLICATIONS

- Floating/stacked ion or e-beam biases
- Floating filament bias
- Floating pulsers and gated grids
- Floating capacitance meters
- Floating high side current monitors
- Floating leakage testers

ULTRAVOLT EFL SERIES

NORMAL, HALF-QUIET, AND QUIET MODES

All EFLs feature a mode control. Three different models — normal, half-quiet, and quiet — are selectable via the voltage level at the mode pin. A voltage between -1.0 and +0.8 V keeps the unit in normal mode; the up and down analog channels follow their inputs. If the mode feature is not used, the mode pin must be grounded for the EFL to operate properly. A voltage more negative than -4.00 V places the EFL in half-quiet mode. The up channels do not respond to changes in their inputs in half-quiet mode. A voltage greater than +3.75 V and less than +5.0 V places the EFL in quiet mode. In quiet mode, the up and down channels do not respond to changes in their inputs. The voltage level at the mode pin must not exceed +5.0 V at any time. Please contact Advanced Energy for an analysis of your requirements.

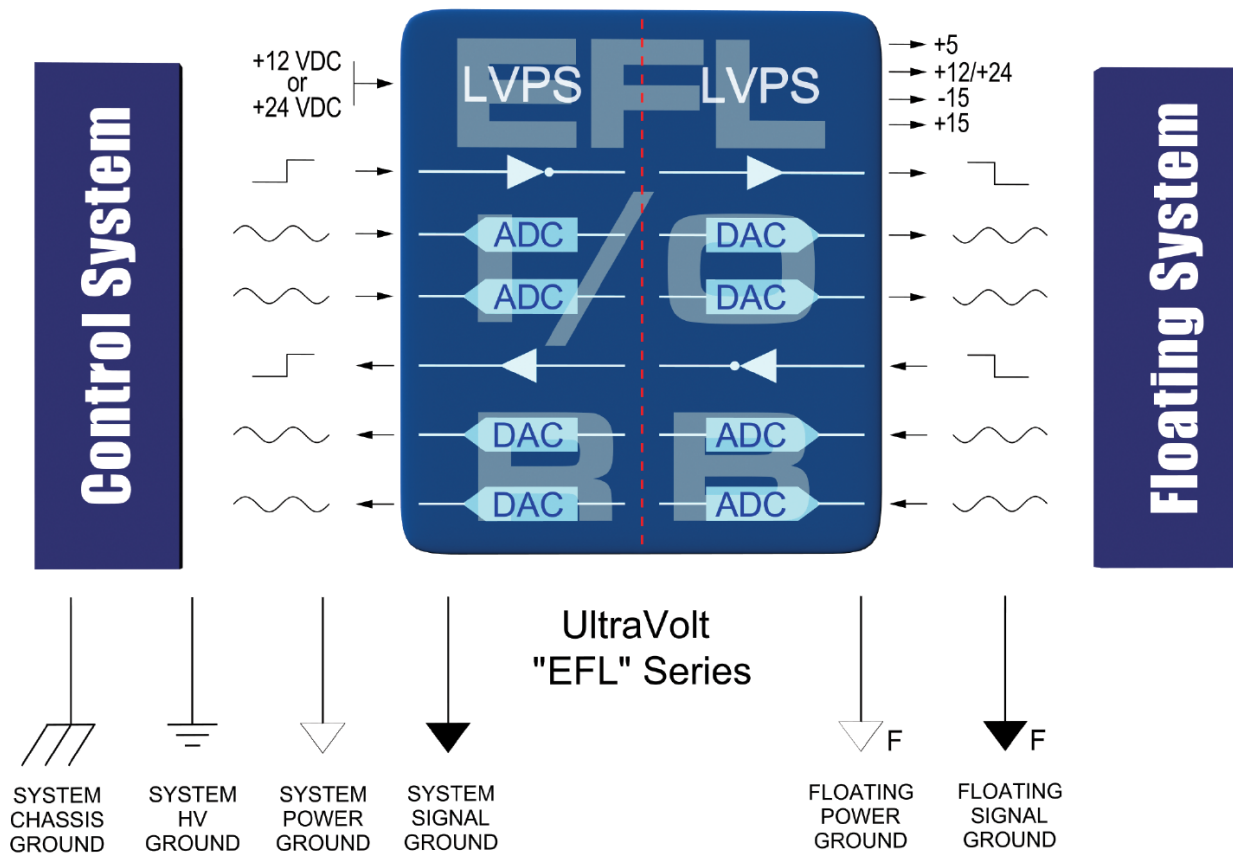

Note: If a voltage >0.8 V is applied to the mode pin, it must source less than 400 μ A.

ELECTRICAL SPECIFICATIONS

Parameter	Conditions	Models			Units
Input		12 W	24 W	36 W (15 kV only)	
Voltage Range	Full Power	+12 ±5%	+24 ±10%	+24 ±10%	VDC
Current	Standby (Disabled)	<150	<100	<100	mA
Current	No Load	<0.50	<0.50	<0.50	A
Current	Max Load	<2.50	<2.30	<3.00	A
AC Ripple Current	Nominal Input, Full Load	<50	<50	<50	mA pk to pk
Local Controls: Reference		All Types			
Output Voltage	T = +25°C, Initial Value	+5.1 ±2%			VDC
Output Impedance	T = +25°C	464 ±1%			Ω
Stability	Over Full Temperature Range	0.4			mV/°C
Local Controls: Reference LVPS Enable/Disable		All Types			
Power Supply On	Open, or a Voltage Above TTL High (I _{source} < 400 μA)	+3.2 to 5			VDC
Power Supply Off	Grounded, or a Voltage Below TTL Low	< 0.8 (I _{sink} 1 mA min)			VDC
Input/Output Isolation		15EFL	30EFL		
Isolation Voltage	Continuous	15	30		kV
Isolation Resistance	All Inputs to All Outputs	150	2		GΩ
Leakage Capacitance	All Inputs to All Outputs	<40 std, <50 “-E”	<40 std		pF

Parameter	Conditions	Models			Units
Isolated Power Outputs		12 W	24 W	36 W (15 kV only)	
Output #1 Power	Nominal Input, Max I _{out}	12	24	36	W
Output #1 Voltage	Nominal Input Voltage Range	+12 ±2%	+24 ±2%	+24 ±2%	VDC
Output #1 Current	Min to Max	0 to 1	0 to 1	0 to 1.5	A
Output #1 Line Regulation	Nominal Input Range, Full Load	<0.1%	<0.1%	<0.1%	VDC
Output #1 Load Regulation	No Load to Full Load	<0.25%	<0.30%	<0.40%	VDC
Output #1 Ripple	Full Load	<2.5%	<1.5%	<1.5%	V pk to pk
Output #2 and #4 Voltage	Nominal Input Voltage Range	±15 ±5%	±15 ±5%	±15 ±5%	VDC
Output #2 and #4 Current	Min to Max	0 to 50	0 to 50	0 to 50	VDC
Output #2 and #4 Line Regulation	Nominal Input Range, Full Load	<0.3%	<0.3%	<0.3%	VDC
Output #2 and #4 Load Regulation	No Load to Full Load	<5%	<1%	<1%	VDC
Output #2 and #4 Ripple	Full Load	<2.5%	<2.5%	<2.5%	VDC
Output #3 Voltage	Nominal Input Voltage Range	+5.1 ±1%	+5.1 ±1%	+5.1 ±1%	VDC
Output #3 Current	Min to Max	500	500	500	mA
Output #3 Line Regulation	Nominal Input Range, Full Load	<1%	<1%	<1%	VDC
Output #3 Load Regulation	No Load to Full Load	<1%	<1%	<1%	VDC
Output #3 Ripple	Full Load	<4%	<4%	<4%	V pk to pk

ULTRAVOLT EFL SERIES

ELECTRICAL SPECIFICATIONS (CONTINUED)

Parameter	Conditions	Models	Units
Isolated Controls: TTL Channel "Up"		All Types	
Local Output	Source Voltage, Sink Current	0 ≤ 0.5 (Isink 3 mA min)	
		1 ≥ 2.4 (300 μA max or open collector)	VDC
Isolated Output	Inverted and Buffered TTL	1 ≥ 2.4, 0 ≤ 0.55 ± (sources 0.8 mA, sinks 3 mA)	VDC
Baud Rate	Duty Cycle	<15	ms
Isolated Controls: Analog "Up"		12 V	24 V
Local Input Voltage	Range	0 to +5	0 to +10
Isolated Output Voltage	Range	0 to +5	0 to +10
Local Input Impedance		20.0 K	Ω
Initial Offset Error		< ±2	mV
Gain Error	Full Scale	< ±0.2%	VDC
Linearity Error	Full Scale	< ±0.05%	VDC
Stability	30 Min Warmup, Per 8 h, per day	< 0.02%	VDC
Temperature Coefficient	0 to +55°C	< ±10	ppm/°C
Bandwidth	Symmetric or Asymmetric Signal	DC to 4	Hz
-RB' Isolated Controls: TTL Channel "Down"		All Types	
Isolated 'Hot Deck' Input	Source Voltage, Sink Current	0 ≤ 0.5 (Isink 1 mA Min)	VDC
		1 ≥ 2.4 (300 μA max or open collector)	VDC
Local Output	Inverted and Buffered TTL	1 > 2.4 (sources 0.8 mA)	VDC
		0 < 0.55 (sinks 10 mA)	VDC
Propagation Delay	Duty Cycle	<15	ms

ELECTRICAL SPECIFICATIONS (CONTINUED)

Parameter	Conditions	Models	Units
Isolated Controls: Analog Channels #1 and #2 "Down"		All Types	
Isolated 'Hot Deck' Input	Range	0 to +5 for 12 V and 0 to +10 for 24 V	VDC
Isolated 'Hot Deck' -Input	Range	0 to -5 for 12 V and 0 to -10 for 24 V	VDC
Isolated 'Hot Deck' + or -Input impedance	Signal Source	>10	MΩ
Local Output +Voltage	Range	0 to +5 for 12 V and 0 to +10 for 24 V	VDC
Local Output -Voltage	Range	0 to -5 for 12 V and 0 to -10 for 24 V	VDC
Initial Offset Error	Signal Source	< ± 2	m VDC
Gain Error	Full Scale	< ±0.2%	VDC
Linearity Error	Full Scale	< ±0.05%	VDC
Stability	30 Min Warmup, Per 8 h, Per Day	< 0.01%/< 0.02%	VDC
Temperature Coefficient	-20 to +55°C	< ±10	ppm/°C
Bandwidth	Symmetric or Asymmetric Signal	DC to 4	Hz
Temperature		All Types	
Operating	Full Load, Case Measurement	-20 to +55°C	
Storage	Non-operating, Case Measurement	-55 to +85°C	
Thermal Shock	Mil-Std-810, Method 503-4, Proc. II	-20 to +55°C	
Altitude		All Types	
Operating	All Operating Conditions	Sea level to vacuum	
Storage	Non-operating	Sea level to vacuum	
Altitude		All Types	
Shock	Mil-Std-810, Method 516.5, Proc. IV 2	20 Gs	
Vibration	Mil-Std-810, Method 514.5, Fig. 514.5C-3	10 Gs	

Note: Analog channels #1 and #2 DOWN parameters are valid for outputs in the range of 10 to 100% of maximum.

ULTRAVOLT EFL SERIES

MECHANICAL SPECIFICATIONS

Construction	
Case	Epoxy-filled DAP box certified to ASTM-D-5948
Volume	15EFL: 181.9 cc (11.1 in ³)
	30EFL: 275.3 cc (16.8 in ³)
Weight	15EFL: 377.1 g (13.3 oz)
	30EFL: 569.8 g (20.1 oz)
Tolerance	Overall $\pm 0.050''$ (1.27 mm)
	Pin to Pin $\pm 0.015''$ (0.38 mm)
	15EFL mounting hole locations $\pm 0.025''$ (0.64 mm)
	30EFL mounting hole locations ± 0.76 mm (0.030")

Note: Pins appear shorter in the outline drawing than actual module to ease visibility of pinout numbers. Minimum pin height from the cover is 7.62 mm (0.300").

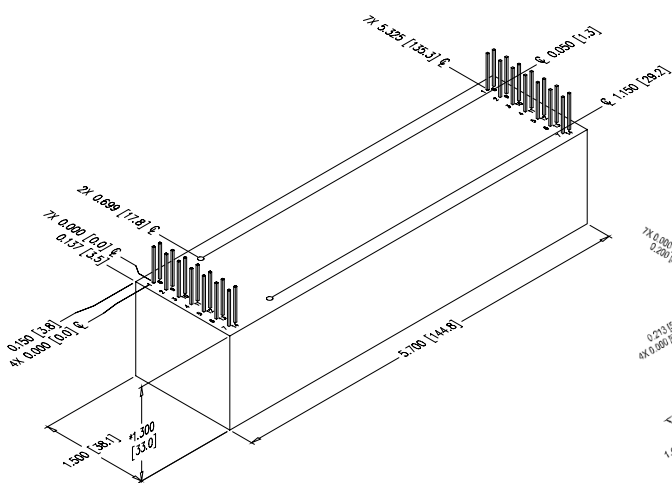

15EFL Module

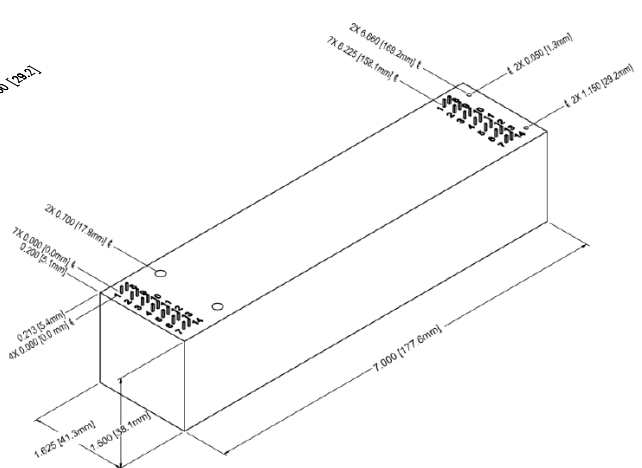

30EFL Module

INTERFACE

Local Connections	
Pin	Function
1	Input Power Ground Return
2	Positive Power Input
3	LVPS Enable/Disable/Sync In
4	TTL Up
5	Signal Ground Return
6	Analog Up Channel 1
7	+5 V Reference Output
8	Analog Down Channel 1, +
9	Analog Down Channel 1, -
10	Analog Down Channel 2, +
11	Analog Down Channel 2, -
12	Analog Up Channel 2
13	Mode
14	TTL Output (Inverted Down Channel 1)

Isolated / Floating Connections	
Pin	Function
1	Analog Down Channel 1, +
2	Analog Down Channel 1, -
3	Analog Down Channel 2, +
4	Analog Down Channel 2, -
5	+15 VDC Output
6	Analog Up Channel 2
7	Floating TTL Input (Digital Down Channel 1)
8	Floating Power Ground Return
9	Floating +12 VDC or +24 VDC Output
10	Floating -15 VDC Output
11	Floating TTL Up
12	Floating Signal Ground Return
13	Floating Analog Up Channel 1
14	Floating +5.1 VDC Reference Output

ORDERING INFORMATION

Type	15 kV Isolation	15EFL
	30 kV Isolation	30EFL
Input Voltage	12 VDC Nominal	12
	24 VDC Nominal	24
Power	Watts Output (12 Vin Only)	-12W
	Watts Output (24 Vin Only)	-24W
	Watts Output (15 kVout, 24 Vin Only)	-36W
Standard Features	(1) Digital Up Channel and (2) Analog Up Channels	-I/O
	(1) Digital Down Channel and (2) Analog Down Channels	-R/B
Options	Partial Mu-Metal Shield	-M
Case	Plastic Case—Diallyl Phthalate	Standard
	"Eared" Chassis Mounting Plate (15 kV only)	-E

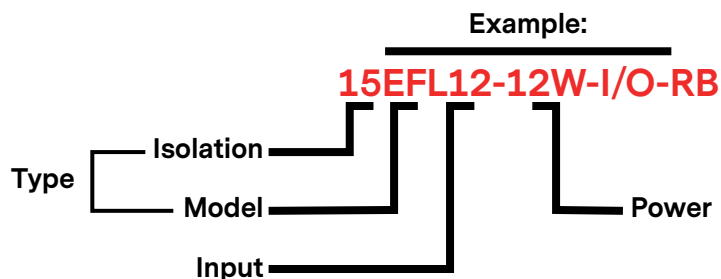



For international contact information,
visit advancedenergy.com.

uv-ca@aei.com
+1.970.221.0108

ABOUT ADVANCED ENERGY

Since 1981, Advanced Energy (AE) — and its UltraVolt® family of products — has perfected how power performs for its customers. For both end users and OEMs, AE's comprehensive portfolio of standard and custom high-voltage components precisely match system specifications to deliver unparalleled energy, quality, and performance. Through close customer collaboration, design expertise, application insight, and world-class support, AE creates successful partnerships and enables customers to push the boundaries of innovation and stay ahead of evolving market needs.

PRECISION | POWER | PERFORMANCE



CAUTION:
High Voltage

Read and understand all documentation before you install, operate, or maintain Advanced Energy high voltage power supplies. Follow all safety instructions and precautions to protect against property damage and serious or possibly fatal bodily injury. Never defeat safety interlocks or grounds.

Specifications are subject to change without notice. Not responsible for errors or omissions. ©2019 Advanced Energy Industries, Inc. All rights reserved. Advanced Energy®, AE®, and Ultravolt® are U.S. trademarks of Advanced Energy Industries, Inc.



Mouser Electronics

Authorized Distributor

Click to View Pricing, Inventory, Delivery & Lifecycle Information:

[Advanced Energy:](#)

[30EFL12-12W-I/O-RB](#) [30EFL24-24W-I/O-RB](#) [15EFL24-24W-I/O-RB](#) [15EFL12-12W-I/O-RB](#)