200 mA 42 V Input Ultra Low Supply Current VR Evaluation Board

No. EEV-520-S033B-190926

R1525S033B-EV is the evaluation board for R1525 which has the below features, benefits and specifications.

OVERVIEW

The R1525S is a low supply current voltage regulator featuring 200mA output current and up to 42 V input voltage. By providing excellent noise immunity, this device is suitable for the power source for control unit used under the electromagnetic environment.

KEY BENEFITS

- Achieves low-supply current of 2.2 μA (Typ.) with the LDO at maximum rating 50 V (Peak Inrush Voltage: 60 V).
- Ensures the design margin by the output voltage with high-accuracy of $\pm 0.6\%$ ($T_a = 25^\circ\text{C}$).
- Protects the output voltage variations in high-frequency noise band (10 MHz to 1 GHz).

KEY SPECIFICATIONS

- Input Voltage Range: 3.5 V to 42.0 V
- Maximum Rating: 50 V (Peak Inrush Voltage: 60 V@200 ms or less)
- Operating Temperature Range: -40°C to 105°C
- Supply Current: Typ. 2.2 μA (Typ. 0.1 μA at Standby)
- Dropout Voltage: Typ. 0.6 V ($I_{\text{OUT}} = 200 \text{ mA}$, $V_{\text{OUT}} = 5.0 \text{ V}$)
- Output Voltage Range: 1.8 V, 2.5 V, 2.8 V, 3.0 V, 3.3 V, 3.4 V, 5.0 V, 5.5 V, 6.0 V, 6.4 V, 8.0 V, 8.5 V, 9.0 V
- Output Voltage Accuracy: $\pm 0.6\%$ ($T_a = 25^\circ\text{C}$)
 $\pm 1.6\%$ ($-40^\circ\text{C} \leq T_a \leq 105^\circ\text{C}$)
- Input Stability: Typ. 0.01%/V ($V_{\text{SET}} + 1 \text{ V} \leq V_{\text{IN}} \leq 42 \text{ V}$)
- Short-circuit Protection: Limited to Typ. 80 mA
- Overcurrent Protection: Limited to Typ. 350 mA
- Package HSOP-6J
- For more details on R1525 IC, please refer to
https://www.e-devices.ricoh.co.jp/en/products/power/vr_ldo/r1525/r1525-ea.pdf.

PCB LAYOUT

R1525S (Package: HSOP-6J) PCB Layout

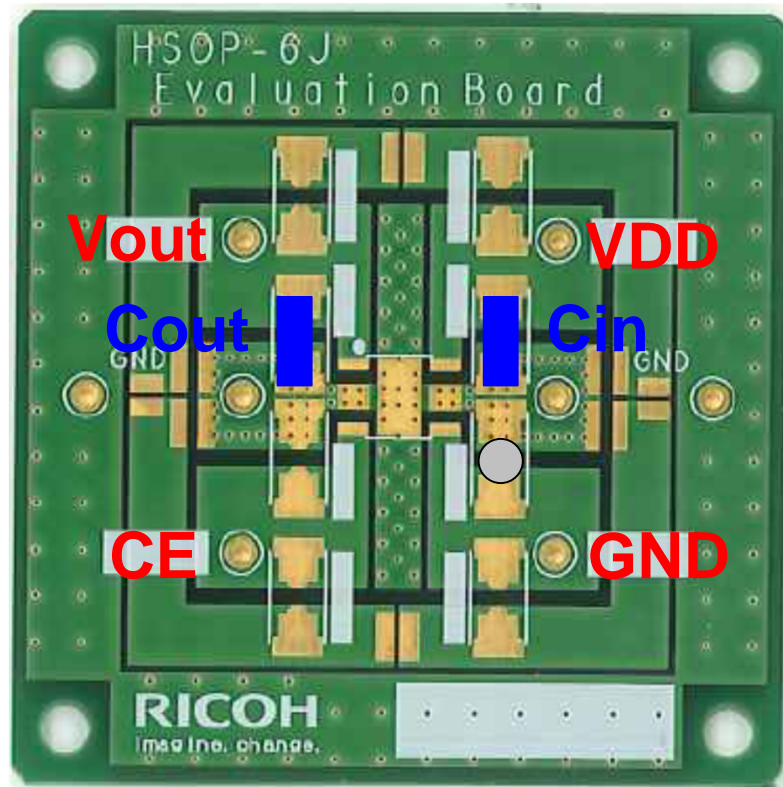

○ : Jumper

ABSOLUTE MAXIMUM RATINGS

Absolute Maximum Ratings

Symbol	Parameter		Rating	Unit
V_{IN}	Input Voltage		-0.3 to 50	V
V_{IN}	Peak Inrush Voltage ⁽¹⁾		60	V
V_{CE}	CE Pin Input Voltage		-0.3 to 50	V
V_{OUT}	Output Voltage		-0.3 to $V_{IN} + 0.3 \leq 50$	V
I_{OUT}	Output Current		300	mA
P_D	Power Dissipation ⁽²⁾ (JEDEC STD. 51-7)	HSOP-6J	2700	mW
T_j	Junction Temperature		-40 to 125	°C
T_{stg}	Storage Temperature Range		-55 to 125	°C

ABSOLUTE MAXIMUM RATINGS

Electronic and mechanical stress momentarily exceeded absolute maximum ratings may cause the permanent damages and may degrade the life time and safety for both device and system using the device in the field. The functional operation at or over these absolute maximum ratings is not assured.

RECOMMENDED OPERATING CONDITIONS

Recommended Operating Conditions

Symbol	Parameter	Rating	Unit
V_{IN}	Input Voltage	3.5 to 42	V
T_a	Operating Temperature Range	-40 to 105	°C

RECOMMENDED OPERATING CONDITONS

All of electronic equipment should be designed that the mounted semiconductor devices operate within the recommended operating conditions. The semiconductor devices cannot operate normally over the recommended operating conditions, even if when they are used over such conditions by momentary electronic noise or surge. And the semiconductor devices may receive serious damage when they continue to operate over the recommended operating conditions.

⁽¹⁾ Duration: 200 ms or less

⁽²⁾ Refer to *POWER DISSIPATION* for detailed information.

TYPICAL APPLICATION

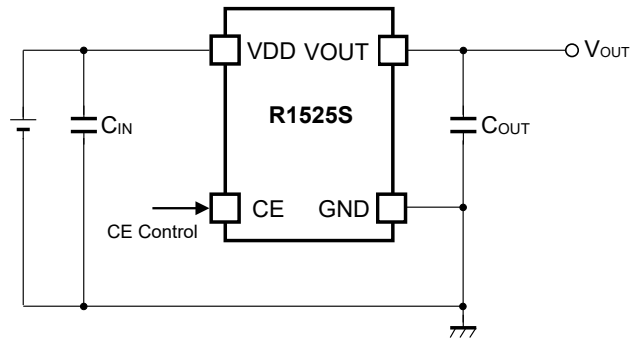

R1525S Typical Application

※Although C_{OUT} operates even at $0.1 \mu\text{F}$, $C_{OUT} = 10 \mu\text{F}$ is recommended to improve transient characteristics.

Recommended External Components*1

Symbol	Value
C_{IN}	$0.1 \mu\text{F}$
C_{OUT}	$10 \mu\text{F}$

*1 The bill of materials will be attached on the shipment of each purchased evaluation board.

PIN DESCRIPTION

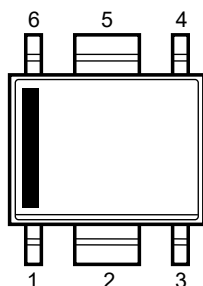

HSOP-6J Pin Configuration

HSOP-6J Pin Descriptions

Pin No.	Symbol	Description
1	V_{OUT}	Output Pin
2	GND ⁽¹⁾	Ground Pin
3	CE	Chip Enable Pin (Active-high)
4	GND ⁽¹⁾	Ground Pin
5	GND ⁽¹⁾	Ground Pin
6	V_{DD}	Input Pin

⁽¹⁾ The GND pin must be wired together when it is mounted on board.

TECHNICAL NOTES

Phase Compensation

Phase compensation is provided to secure stable operation even when the load current is varied. For this purpose, make sure to use 0.1 μF or more of a capacitor (C_{OUT}). In case of using a tantalum type capacitor and the ESR (Equivalent Series Resistance) value of the capacitor is large, the output might be unstable. Evaluate the circuit including consideration of frequency characteristics. Connect 0.1 μF or more of a capacitor (C_{IN}) between V_{DD} and GND, and as close as possible to the pins.

PCB Layout

For HSOP-6J package type, wire the following GND pins together: No. 2, No. 4, and No. 5.

Input Transient / Load Transient vs. Output Capacity (C_{OUT})

R1525S performs a stable operation by using 0.1 μF of ceramic capacitor as the output capacitor. However, the variation of output voltage may not meet the demand of the system when input voltage and load current vary. In such cases, the variation of output voltage can be minimized significantly by using 10 μF or higher ceramic capacitor. When using an electrolytic capacitor for the output line, place the electrolytic capacitor outer side of the ceramic capacitor arranged close to the IC.



1. The products and the product specifications described in this document are subject to change or discontinuation of production without notice for reasons such as improvement. Therefore, before deciding to use the products, please refer to Ricoh sales representatives for the latest information thereon.
2. The materials in this document may not be copied or otherwise reproduced in whole or in part without prior written consent of Ricoh.
3. Please be sure to take any necessary formalities under relevant laws or regulations before exporting or otherwise taking out of your country the products or the technical information described herein.
4. The technical information described in this document shows typical characteristics of and example application circuits for the products. The release of such information is not to be construed as a warranty of or a grant of license under Ricoh's or any third party's intellectual property rights or any other rights.
5. The products listed in this document are intended and designed for use as general electronic components in standard applications (office equipment, telecommunication equipment, measuring instruments, consumer electronic products, amusement equipment etc.). Those customers intending to use a product in an application requiring extreme quality and reliability, for example, in a highly specific application where the failure or misoperation of the product could result in human injury or death (aircraft, spacevehicle, nuclear reactor control system, traffic control system, automotive and transportation equipment, combustion equipment, safety devices, life support system etc.) should first contact us.
6. We are making our continuous effort to improve the quality and reliability of our products, but semiconductor products are likely to fail with certain probability. In order to prevent any injury to persons or damages to property resulting from such failure, customers should be careful enough to incorporate safety measures in their design, such as redundancy feature, fire containment feature and fail-safe feature. We do not assume any liability or responsibility for any loss or damage arising from misuse or inappropriate use of the products.
7. Anti-radiation design is not implemented in the products described in this document.
8. The X-ray exposure can influence functions and characteristics of the products. Confirm the product functions and characteristics in the evaluation stage.
9. WLCSP products should be used in light shielded environments. The light exposure can influence functions and characteristics of the products under operation or storage.
10. There can be variation in the marking when different AOI (Automated Optical Inspection) equipment is used. In the case of recognizing the marking characteristic with AOI, please contact Ricoh sales or our distributor before attempting to use AOI.
11. Please contact Ricoh sales representatives should you have any questions or comments concerning the products or the technical information.



Ricoh is committed to reducing the environmental loading materials in electrical devices with a view to contributing to the protection of human health and the environment.

Ricoh has been providing RoHS compliant products since April 1, 2006 and Halogen-free products since April 1, 2012.

RICOH RICOH ELECTRONIC DEVICES CO., LTD.

Official website

<https://www.e-devices.ricoh.co.jp/en/>

Contact us

<https://www.e-devices.ricoh.co.jp/en/support/>

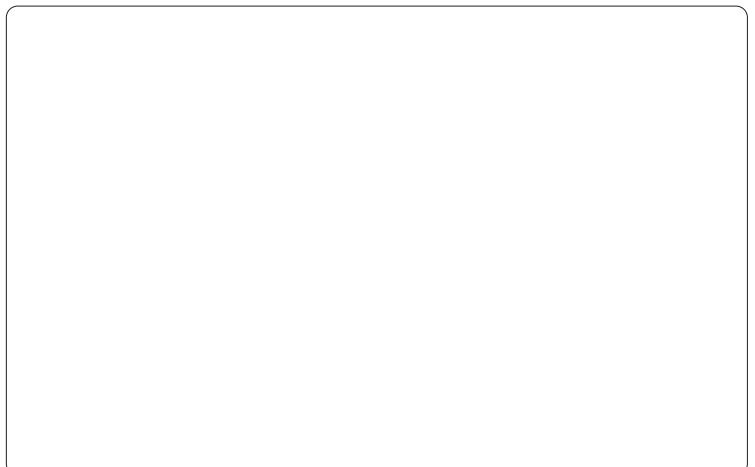

Mouser Electronics

Authorized Distributor

Click to View Pricing, Inventory, Delivery & Lifecycle Information:

[Ricoh Electronics:](#)

[R1525S033B-EV](#)