

## Dual T1/E1 Line Interface

### Features

- Dual T1/E1 Line Interface
- Low Power Consumption (Typically 220mW per Line Interface)
- Matched Impedance Transmit Drivers
- Common Transmit and Receive Transformers for all Modes
- Selectable Jitter Attenuation for Transmit or Receive Paths
- Supports JTAG Boundary Scan
- Hardware Mode Derivative of the CS61584

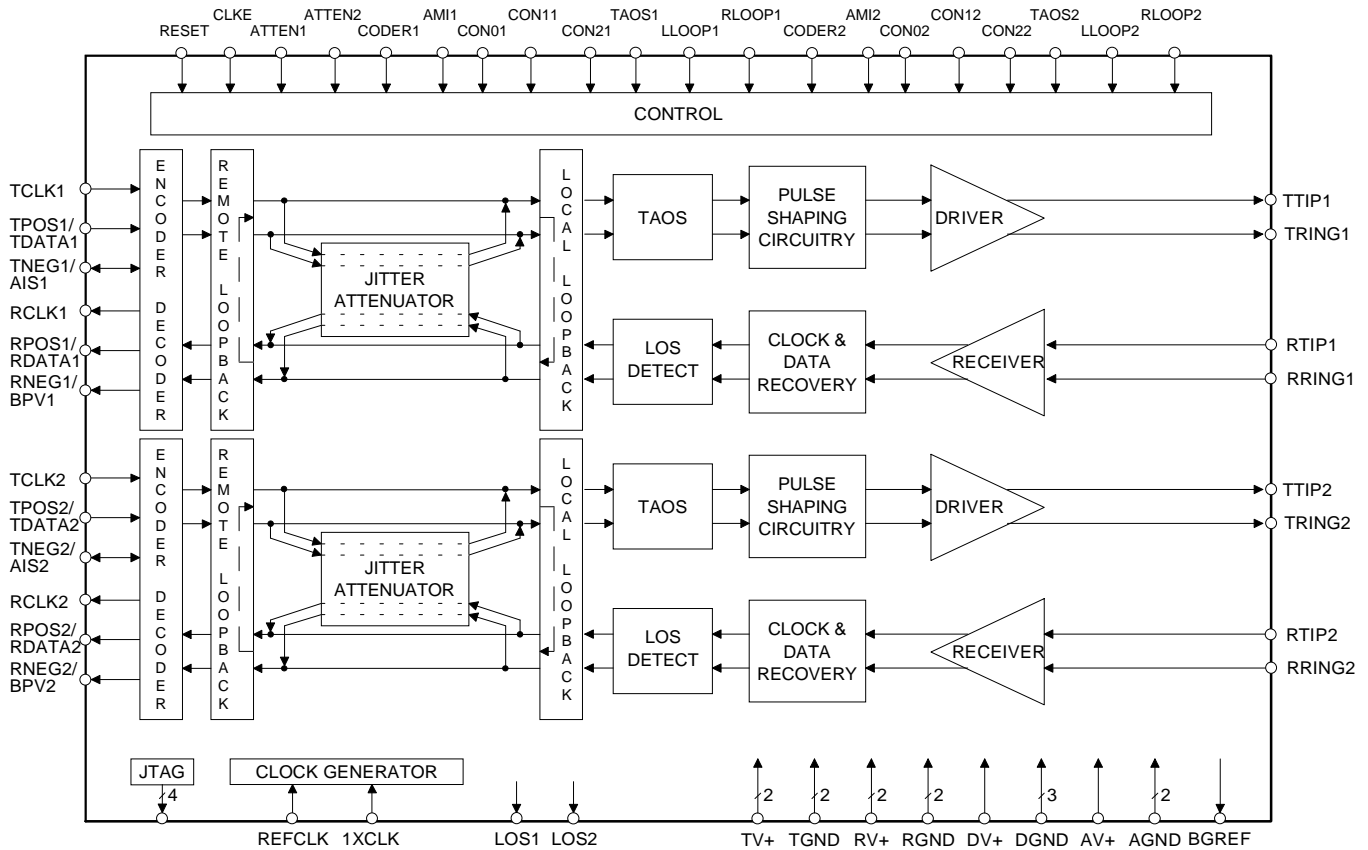
### General Description

The CS61583 is a dual line interface for T1/E1 applications, designed for high-volume cards where low power and high density are required. Each channel features individual control and status pins which eliminates the need for external microprocessor support. The matched impedance drivers reduce power consumption and provide substantial return loss to insure superior T1/E1 pulse quality.

The CS61583 provides JTAG boundary scan to enhance system testability and reliability. The CS61583 is a 5 volt device and is a hardware mode derivative of the CS61584.

### ORDERING INFORMATION

- CS61583-IL5: 68-pin PLCC, -40 to +85 °C
- CS61583-IQ5: 64-pin TQFP, -40 to +85 °C



**Table of Contents**

Block Diagram . . . . .	1
Specifications	
Absolute Maximum Ratings. . . . .	3
Recommended Operating Conditions. . . . .	3
Digital Characteristics. . . . .	4
Analog Specifications	
Receiver . . . . .	4
Jitter Attenuator . . . . .	4
Transmitter . . . . .	5
Switching Characteristics	
T1 Clock/Data. . . . .	6
E1 Clock/Data. . . . .	6
JTAG. . . . .	8
General Description	
Overview. . . . .	9
Transmitter . . . . .	10
Receiver . . . . .	12
Jitter Attenuator . . . . .	12
Reference Clock . . . . .	13
Power-Up Reset . . . . .	13
Line Control and Monitoring . . . . .	13
Line Code Encoder/Decoder. . . . .	13
Alarm Indication Signal . . . . .	14
Bipolar Violation Detection . . . . .	14
Loss of Signal. . . . .	14
Transmit All Ones . . . . .	14
Local Loopback . . . . .	14
Remote Loopback. . . . .	14
Reset Pin. . . . .	14
JTAG Boundary Scan. . . . .	15
Pin Description . . . . .	23
Physical Dimensions. . . . .	29
Applications . . . . .	31

## ABSOLUTE MAXIMUM RATINGS

Parameter	Symbol	Min	Max	Units
DC Supply (TV+1, TV+2, RV+1, RV+2, AV+, DV+) (Note 1)		-	6.0	V
Input Voltage (Any Pin)	$V_{in}$	RGND - 0.3	(RV+) + 0.3	V
Input Current (Any Pin) (Note 2)	$I_{in}$	-10	10	mA
Ambient Operating Temperature	$T_A$	-40	85	°C
Storage Temperature	$T_{stg}$	-65	150	°C

WARNING: Operations at or beyond these limits may result in permanent damage to the device.  
Normal operation is not guaranteed at these extremes.

Notes: 1. Referenced to RGND1, RGND2, TGND1, TGND2, AGND, DGND at 0V.  
2. Transient currents of up to 100 mA will not cause SCR latch-up.

## RECOMMENDED OPERATING CONDITIONS

Parameter	Symbol	Min	Typ	Max	Units
DC Supply (TV+1, TV+2, RV+1, RV+2, AV+, DV+) (Note 3)		4.75	5.0	5.25	V
Ambient Operating Temperature	$T_A$	-40	25	85	°C
Power Consumption (Each Channel)	T1 (Notes 4 and 5)	-	310	-	mW
	T1 (Notes 4 and 6)	-	220	-	mW
	E1, 75Ω (Notes 4 and 5)	-	275	-	mW
	E1, 120Ω (Notes 4 and 5)	-	275	-	mW
REFCLK Frequency	T1 1XCLK = 1	1.544 - 100 ppm	1.544	1.544 + 100 ppm	MHz
	T1 1XCLK = 0	12.352 - 100 ppm	12.352	12.352 + 100 ppm	MHz
	E1 1XCLK = 1	2.048 - 100 ppm	2.048	2.048 + 100 ppm	MHz
	E1 1XCLK = 0	16.384 - 100 ppm	16.384	16.384 + 100 ppm	MHz

Notes: 3. TV+1, TV+2, AV+, DV+, RV+1, RV+2 should be connected together. TGND1, TGND2, RGND1, RGND2, DGND1, DGND2, DGND3 should be connected together.  
4. Power consumption while driving line load over operating temperature range. Includes IC and load. Digital input levels are within 10% of the supply rails and digital outputs are driving a 50 pF capacitive load.  
5. Assumes 100% ones density and maximum line length at 5.25V.  
6. Assumes 50% ones density and 300ft. line length at 5.0V.

**DIGITAL CHARACTERISTICS** ( $T_A = -40$  to  $85$  °C; power supply pins within  $\pm 5\%$  of nominal)

Parameter	Symbol	Min	Typ	Max	Units
High-Level Input Voltage (Note 7)	$V_{IH}$	(DV+)-0.5	-	-	V
Low-Level Input Voltage (Note 7)	$V_{IL}$	-	-	0.5	V
High-Level Output Voltage (Digital pins) $I_{OUT} = -40 \mu A$ (Note 8)	$V_{OH}$	(DV+)-0.3	-	-	V
Low-Level Output Voltage (Digital pins) $I_{OUT} = 1.6 mA$ (Note 8)	$V_{OL}$	-	-	0.3	V
Input Leakage Current (Digital pins except J-TMS, and J-TDI)		-	-	$\pm 10$	$\mu A$

Notes: 7. Digital inputs are designed for CMOS logic levels.

8. Digital outputs are TTL compatible and drive CMOS levels into a CMOS load.

**ANALOG SPECIFICATIONS** ( $T_A = -40$  to  $85$  °C; power supply pins within  $\pm 5\%$  of nominal)

Parameter	Min	Typ	Max	Units	
<b>Receiver</b>					
RTIP/RRING Differential Input Impedance	-	20k	-	$\Omega$	
Sensitivity Below DSX-1 (0 dB = 2.4 V)	-13.6	-	-	dB	
Loss of Signal Threshold	-	0.3	-	V	
Data Decision Threshold	T1, DSX-1 (Note 9) E1 (Note 10) E1 (Note 11) E1 (Note 12)	60 55 45 40	65 - 50 -	70 75 55 60	% of Peak
Allowable Consecutive Zeros before LOS	160	175	190	bits	
Receiver Input Jitter Tolerance (DSX-1, E1)	10 Hz and below 2 kHz 10 kHz - 100 kHz	(Note 13) 300 6.0 0.4	- - -	- - -	UI UI UI
Receiver Return Loss	51 kHz - 102 kHz 102 kHz - 2.048 MHz 2.048 MHz - 3.072 MHz	(Notes 14, 21, and 22) 12 18 14	- - -	- - -	dB dB dB
<b>Jitter Attenuator</b>					
Jitter Attenuation Curve	T1 (Notes 14 and 15)	-	4	-	Hz
Corner Frequency	E1	-	5.5	-	Hz
Attenuation at 10 kHz Jitter Frequency	(Notes 14 and 15)	-	60	-	dB
Attenuator Input Jitter Tolerance (Before Onset of FIFO Overflow or Underflow Protection)	(Note 14)	28	43	-	$UI_{pk-pk}$

Notes: 9. For input amplitude of  $1.2 V_{pk}$  to  $4.14 V_{pk}$

10. For input amplitude of  $0.5 V_{pk}$  to  $1.2 V_{pk}$ , and  $4.14 V_{pk}$  to  $5.0 V_{pk}$

11. For input amplitude of  $1.07 V_{pk}$  to  $4.14 V_{pk}$ ,

12. For input amplitude of  $4.14 V_{pk}$  to  $5.0 V_{pk}$ ,

13. Jitter tolerance increases at lower frequencies. Refer to the Receiver section.

14. Not production tested. Parameters guaranteed by design and characterization.

15. Attenuation measured with sinusoidal input jitter equal to 3/4 of measured jitter tolerance.

Circuit attenuates jitter at 20 dB/decade above the corner frequency. Output jitter can increase significantly when more than 28 UI's are input to the attenuator. Refer to the Jitter Attenuator section.

**ANALOG SPECIFICATIONS** ( $T_A = -40$  to  $85$  °C; power supply pins within  $\pm 5\%$  of nominal)

Parameter		Min	Typ	Max	Units
<b>Transmitter</b>					
AMI Output Pulse Amplitudes	(Note 16)				
E1, 75 $\Omega$	(Note 17)	2.14	2.37	2.6	V
E1, 120 $\Omega$	(Note 18)	2.7	3.0	3.3	V
T1, DSX-1	(Note 19)	2.4	3.0	3.6	V
Recommended Transmitter Output Load	(Note 16)				
T1		-	76.6	-	$\Omega$
E1, 75 $\Omega$		-	57.4	-	$\Omega$
E1, 120 $\Omega$		-	90.6	-	$\Omega$
Jitter Added During Remote Loopback					
10 Hz - 8 kHz		-	0.005	-	UI
8 kHz - 40 kHz		-	0.008	-	UI
10 Hz - 40 kHz		-	0.010	-	UI
Broad Band	(Note 20)	-	0.015	-	UI
Power in 2 kHz band about 772 kHz	(Notes 14 and 21) (DSX-1 only)	12.6	15	17.9	dBm
Power in 2 kHz band about 1.544 MHz (referenced to power in 2 kHz band at 772 kHz)	(Notes 14 and 21) (DSX-1 only)	-29	-38	-	dB
Positive to Negative Pulse Imbalance	(Notes 14 and 21)				
T1, DSX-1		-	0.2	0.5	dB
E1, amplitude at center of pulse interval		-5	-	+5	%
E1, width at 50% of nominal amplitude		-5	-	+5	%
Transmitter Return Loss	(Notes 14, 21, and 22)				
51 kHz - 102 kHz		18	25	-	dB
102 kHz - 2.048 MHz		14	18	-	dB
2.048 MHz - 3.072 MHz		10	12	-	dB
E1 Short Circuit Current	(Note 23)	-	-	50	mA <sub>rms</sub>
E1 and DSX-1 Output Pulse Rise/Fall Times	(Note 24)	-	25	-	ns
E1 Pulse Width (at 50% of peak amplitude)		-	244	-	ns
E1 Pulse Amplitude for a space	E1, 75 $\Omega$ E1, 120 $\Omega$	-0.237 -0.3	- -	0.237 0.3	V V

- Notes: 16. Using a transformer that meets the specifications in the Applications section.  
17. Measured across 75  $\Omega$  at the output of the transmit transformer for CON2/1/0 = 0/0/0.  
18. Measured across 120  $\Omega$  at the output of the transmit transformer for CON2/1/0 = 0/0/1.  
19. Measured at the DSX-1 cross-connect for line length settings CON2/1/0 = 0/1/0, 0/1/1, 1/0/0, 1/0/1, and 1/1/0 after the appropriate length of #22 ABAM cable specified in Table 1.  
20. Input signal to RTIP/RRING is jitter free. Values will reduce slightly if jitter free clock is input to TCLK.  
21. Typical performance using the line interface circuitry recommended in the Applications section.  
22. Return loss =  $20 \log_{10} \text{ABS}((z_1+z_0)/(z_1-z_0))$  where  $z_1$ =impedance of the transmitter or receiver, and  $z_0$ =cable impedance.  
23. Transformer secondary shorted with 0.5  $\Omega$  resistor during the transmission of 100% ones.  
24. At transformer secondary and measured from 10% to 90% of amplitude.

**SWITCHING CHARACTERISTICS - T1 CLOCK/DATA** ( $T_A = -40$  to  $85$  °C; power supply pins within  $\pm 5\%$  of nominal; Inputs: Logic 0 = 0V, Logic 1 = DV+) (See Figures 1, 2, and 3)

Parameter	Symbol	Min	Typ	Max	Units
TCLK Frequency (Note 25)	$f_{tclk}$	-	1.544	-	MHz
TCLK Duty Cycle	$t_{pwh2}/t_{pw2}$	30	50	70	%
RCLK Duty Cycle (Note 26)	$t_{pwh1}/t_{pw1}$	45	50	55	%
Rise Time (All Digital Outputs) (Note 27)	$t_r$	-	-	65	ns
Fall Time (All Digital Outputs) (Note 27)	$t_f$	-	-	65	ns
RPOS/RNEG (RDATA) to RCLK Rising Setup Time	$t_{su1}$	-	274	-	ns
RCLK Rising to RPOS/RNEG (RDATA) Hold Time	$t_{h1}$	-	274	-	ns
TPOS/TNEG (TDATA) to TCLK Falling Setup Time	$t_{su2}$	25	-	-	ns
TCLK Falling to TPOS/TNEG (TDATA) Hold Time	$t_{h2}$	25	-	-	ns

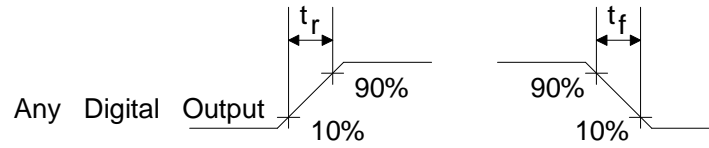
Notes: 25. The maximum burst rate of a gapped TCLK input clock is 8.192 MHz. For the gapped clock to be tolerated by the CS61583, the jitter attenuator must be switched to the transmit path of the line interface. The maximum gap size that can be tolerated on TCLK is 28 Ulp-p.

26. RCLK duty cycle may be outside the specified limits when the jitter attenuator is in the receive path, and when the jitter attenuator is employing the overflow/underflow protection mechanism.

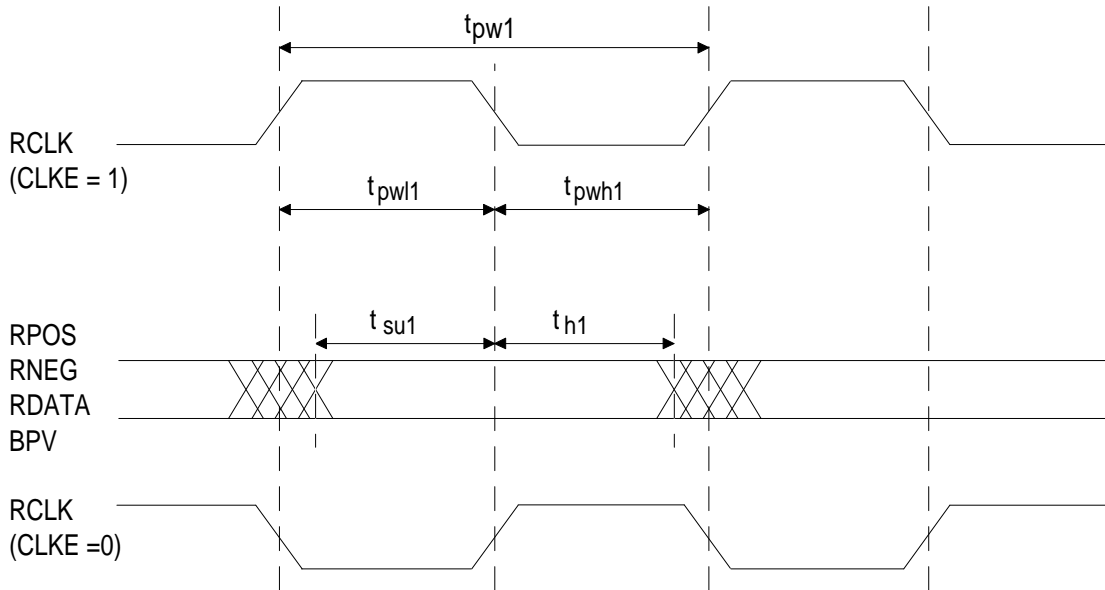
27. At max load of 50 pF.

**SWITCHING CHARACTERISTICS - E1 CLOCK/DATA** ( $T_A = -40$  to  $85$  °C; power supply pins within  $\pm 5\%$  of nominal; Inputs: Logic 0 = 0V, Logic 1 = DV+) (See Figures 1, 2, and 3)

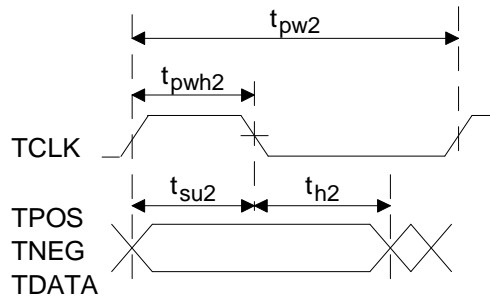
Parameter	Symbol	Min	Typ	Max	Units
TCLK Frequency (Note 25)	$f_{tclk}$	-	2.048	-	MHz
TCLK Duty Cycle	$t_{pwh2}/t_{pw2}$	30	50	70	%
RCLK Duty Cycle (Note 26)	$t_{pwh1}/t_{pw1}$	45	50	55	%
Rise Time (All Digital Outputs) (Note 27)	$t_r$	-	-	65	ns
Fall Time (All Digital Outputs) (Note 27)	$t_f$	-	-	65	ns
RPOS/RNEG (RDATA) to RCLK Rising Setup Time	$t_{su1}$	-	194	-	ns
RCLK Rising to RPOS/RNEG (RDATA) Hold Time	$t_{h1}$	-	194	-	ns
TPOS/TNEG (TDATA) to TCLK Falling Setup Time	$t_{su2}$	25	-	-	ns
TCLK Falling to TPOS/TNEG (TDATA) Hold Time	$t_{h2}$	25	-	-	ns



**Figure 1. Signal Rise and Fall Characteristics**



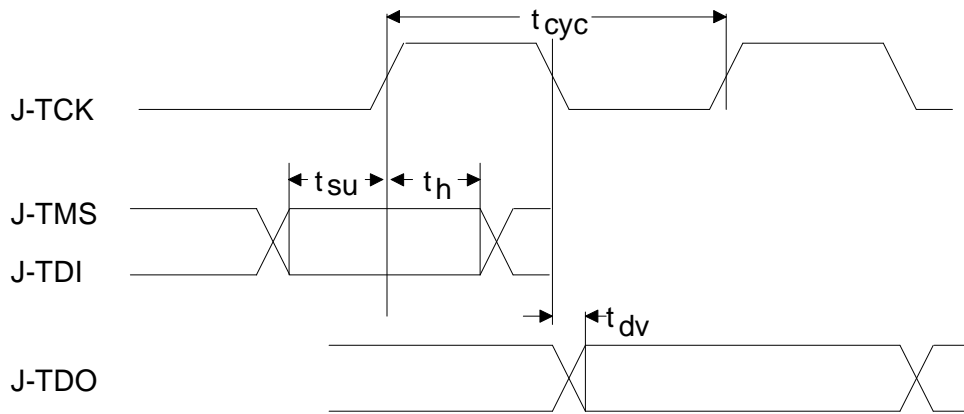
**Figure 2. Recovered Clock and Data Switching Characteristics**



**Figure 3. Transmit Clock and Data Switching Characteristics**

**SWITCHING CHARACTERISTICS - JTAG** ( $T_A = -40^\circ$  to  $85^\circ$  C;  
 TV+, RV+ = nominal  $\pm 0.3V$ ; Inputs: Logic 0 = 0V, Logic 1 = RV+) (See Figure 4)

Parameter	Symbol	Min	Typ	Max	Units
Cycle Time	$t_{cyc}$	200	-	-	ns
J-TMS/J-TDI to J-TCK rising setup time	$t_{su}$	50	-	-	ns
J-TCK rising to J-TMS/J-TDI hold time	$t_h$	50	-	-	ns
J-TCK falling to J-TDO valid	$t_{dv}$	-	-	50	ns



**Figure 4. JAG Switching Characteristics**



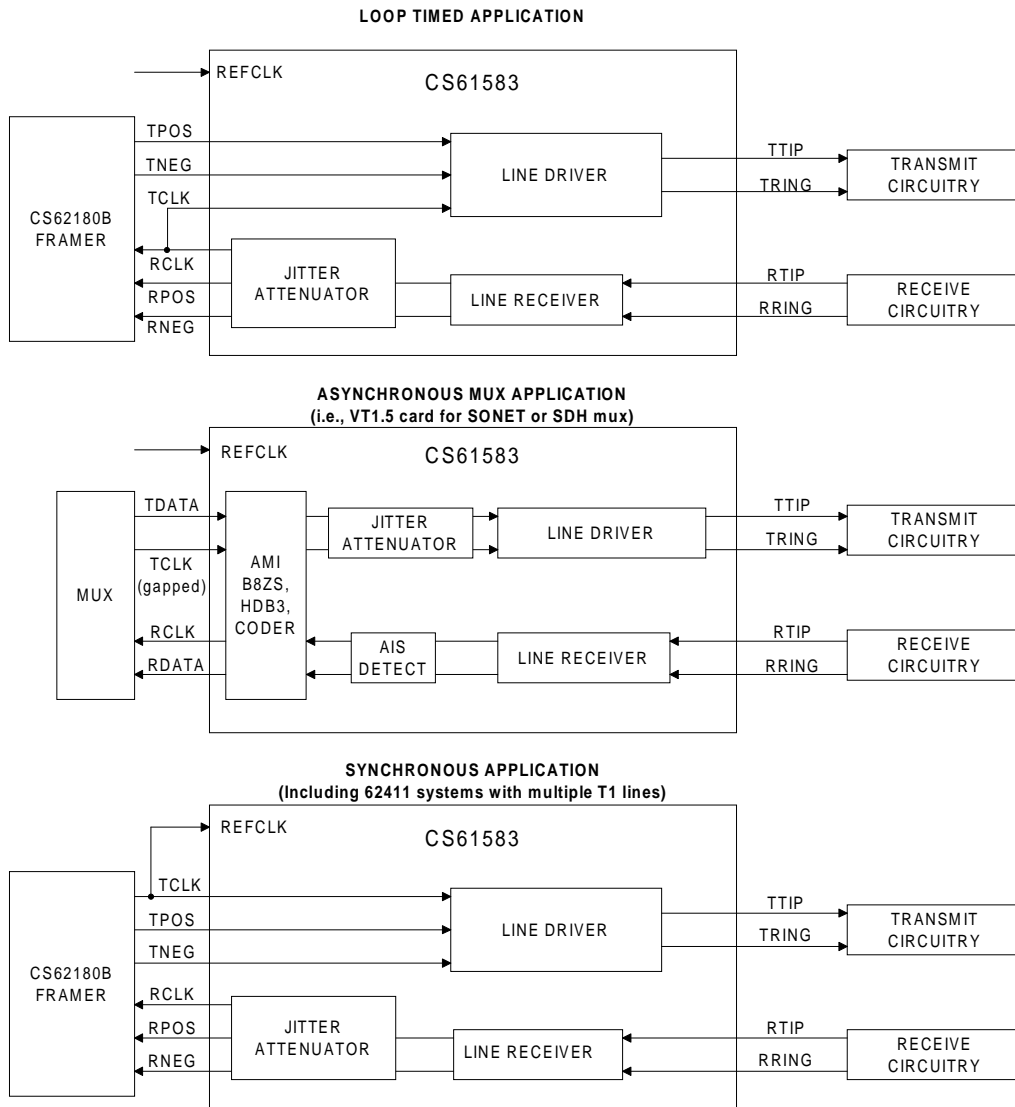
**OVERVIEW**

The CS61583 is a dual line interface for T1/E1 applications, designed for high-volume cards where low power and high density are required. One board design can support all T1/E1 short-haul modes by only changing component values in the receive and transmit paths (if REFCLK and TCLK are externally tied together). Figure 5 illustrates applications of the CS61583 in various environments.

All control of the device is achieved via external pins, eliminating the need for microprocessor

support. The following pin control options are available on a per channel basis: line length selection, coder mode, jitter attenuator location, transmit all ones, local loopback, and remote loopback.

The line driver generates waveforms compatible with E1 (CCITT G.703), T1 short haul (DSX-1), and T1 FCC Part 68 Option A (DS1). A single transformer turns ratio is used for all waveform types. The driver internally matches the impedance of the load, providing excellent return loss to insure superior T1/E1 pulse quality. An addi-



**Figure 5. Examples of CS61583 Applications**

tional benefit of the internal impedance matching is a 50 percent reduction in power consumption compared to implementing return loss using external resistors that causes the transmitter to drive the equivalent of two line loads.

The line receiver contains all the necessary clock and data recovery circuits.

The jitter attenuator meets AT&T 62411 requirements when using a 1X or 8X reference clock supplied by either a crystal oscillator or external reference at the REFCLK input pin.

### ***AT&T 62411 Customer Premises Application***

The AT&T 62411 specification applies to the T1 interface between the customer premises and the carrier, and must be implemented by the customer premises equipment in order to connect to the AT&T network.

In 62411 applications, the management of jitter is a very important design consideration. Typically, the jitter attenuator is placed in the receive path of the CS61583 to reduce the jitter input to the system synchronizer. The jitter attenuated recovered clock is used as the input to the transmit clock to implement a loop-timed system. A Stratum 4 ( $\pm 32$  ppm) quality clock or better should be input to REFCLK. Note that any jitter present on the reference clock will not be filtered by the jitter attenuator.

### ***Asynchronous Multiplexer Application***

Asynchronous multiplexers accept multiple T1/E1 lines (which are asynchronous to each other), and combine them into a higher speed transmission rate (e.g. M13 muxes and SONET muxes). In these systems, the jitter attenuator is placed in the transmit path of the CS61583 to remove the gapped clock jitter input by the multiplexer to TCLK. Because the transmit clock is jittered, the reference clock to the CS61583 is provided by an external source operating at 1X or 8X the data rate. Because T1/E1 framers are

not usually required in asynchronous multiplexers, the B8ZS/AMI/HDB3 coders in the CS61583 are activated to provide data interfaces on TDATA and RDATA.

### ***Synchronous Application***

A typical example of a synchronous application is a T1 card in a central office switch or a 0/1 digital cross-connect system. These systems place the jitter attenuator in the receive path to reduce the jitter presented to the system. A Stratum 3 or better system clock is input to the CS61583 transmit and reference clocks.

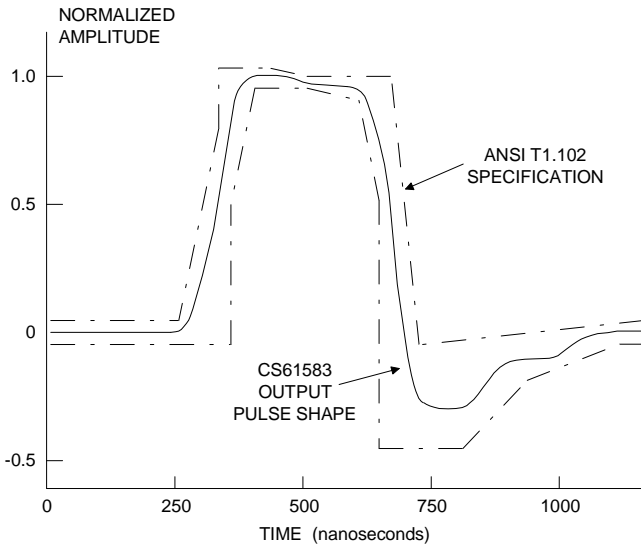
## **TRANSMITTER**

The transmitter accepts data from a T1 or E1 system and outputs pulses of appropriate shape to the line. The transmit clock (TCLK) and transmit data (TPOS & TNEG, or TDATA) are supplied synchronously. Data is sampled on the falling edge of the TCLK input.

The configuration pins CON[2:0] control transmitted pulse shapes, transmitter source impedance, and receiver slicing level as shown in Table 1. Typical output pulses are shown in Figures 6 and 7. These pulse shapes are fully pre-defined by circuitry in the CS61583, and are fully compliant with appropriate standards when used with our application guidelines in standard installations. Both channels must be operated at the same line rate (both T1 or both E1).

Note that the pulse width for Part 68 Option A (324 ns) is narrower than the optimal pulse width for DSX-1 (350 ns). The CS61583 automatically adjusts the pulse width based on the configuration selection.

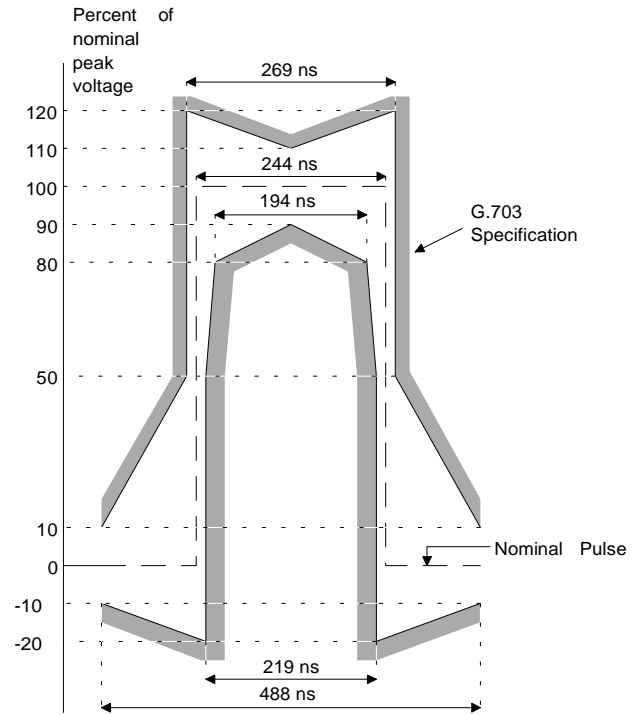
The transmitter impedance changes with the line length options in order to match the load impedance (75 $\Omega$  for E1 coax, 100 $\Omega$  for T1, 120 $\Omega$  for E1 shielded twisted pair), providing a minimum of 14 dB return loss for T1 and E1 frequencies



**Figure 6. Typical Pulse Shape at DSX-1 Cross Connect**

during the transmission of both marks and spaces. This improves signal quality by minimizing reflections from the transmitter. Impedance matching also reduces load power consumption by a factor of two when compared to the return loss achieved by using external resistors.

The CS61583 driver will automatically detect an inactive TLCK input (i.e., no valid data is being clocked to the driver). When this condition is detected, the driver is forced low (except during remote loopback) to output spaces and prevent TTIP and TRING from entering a constant transmit-mark state.



**Figure 7. Pulse Mask at the 2048 kbps Interface**

When any transmit configuration established by CON[2:0], TAOS, or LLOOP changed states, the transmitter stabilizes within 22 TCLK bit periods. The transmitter takes longer to stabilize when RLOOP1 or RLOOP2 is selected because the timing circuitry must adjust to the new frequency from RCLK.

When the transmitter transformer secondaries are shorted through a 0.5 ohm resistor, the transmit-

C O N 2	C O N 1	C O N 0	Transmit Pulse Width at 50% Amplitude	Transmit Pulse Shape	Receiver Slicing Level
0	0	0	244 ns (50%)	E1: square, 2.37 Volts into 75 Ω	50%
0	0	1	244 ns (50%)	E1: square, 3.00 Volts into 120 Ω	50%
0	1	0	350 ns (54%)	DSX-1: 0-133 ft. / or DS1 FCC Part 68 Option A with undershoot	65%
0	1	1	350 ns (54%)	DSX-1: 133-266 ft.	65%
1	0	0	350 ns (54%)	DSX-1: 266-399 ft.	65%
1	0	1	350 ns (54%)	DSX-1: 399-533 ft.	65%
1	1	0	350 ns (54%)	DSX-1: 533-655 ft.	65%
1	1	1	324 ns (50%)	DS1: FCC Part 68 Option A (0 dB)	65%

**Table 1. Configuration Selection**

ter will output a maximum of 50 mA-rms, as required by European specification BS6450.

**RECEIVER**

The receiver extracts data and clock from the T1/E1 signal on the line interface and outputs clock and synchronized data to the system. The signal is detected differentially across the receive transformer and can be recovered over the entire range of short haul cable lengths. The transmit and receive transformer specifications are identical and are presented in the Applications section.

As shown in Table 1, the receiver slicing level is set at 65% for DS1/DSX-1 short-haul and at 50% for all other applications.

The clock recovery circuit is a second-order phase locked loop that can tolerate up to 0.4 UI of jitter from 10 kHz to 100 kHz without generating errors (Figure 8). The clock and data recovery circuit is tolerant of long strings of consecutive zeros and will successfully recover a 1-in-175 jitter-free line input signal.

Recovered data at RPOS and RNEG (or RDATA) is stable and may be sampled using the recovered clock RCLK. The CLKE input determines the clock polarity for which output data is stable and valid as shown in Table 2. When

CLKE is low, RPOS and RNEG (or RDATA) are valid on the rising edge of RCLK. When CLKE is high, RPOS and RNEG (or RDATA) are valid on the falling edge of RCLK.

CLKE	DATA	CLOCK	Clock Edge for Valid Data
LOW	RPOS, RNEG or RDATA	RCLK RCLK	Rising Rising
HIGH	RPOS, RNEG or RDATA	RCLK RCLK	Falling Falling

**Table 2. Recovered Data/Clock Options**

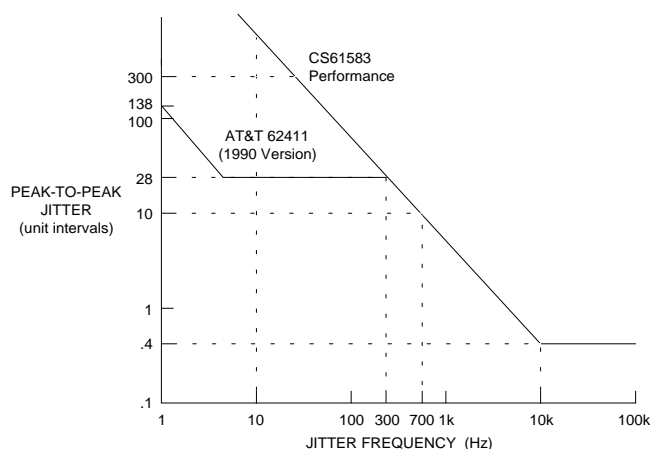
**JITTER ATTENUATOR**

The jitter attenuator can be switched into either the receive or transmit paths. Alternatively, it can also be removed from both paths to reduce the propagation delay.

The location of the attenuators for both channels is controlled by the ATTEN0 and ATTEN1 pins. Table 3 shows how these pins are decoded.

ATTEN1	ATTEN0	Location of Jitter Attenuator
0	0	Receiver
0	1	Disabled
1	0	Transmitter
1	1	Reserved

**Table 3. Jitter Attenuation Control**



**Figure 8. Minimum Input Jitter Tolerance of Receiver (Clock Recovery Circuit and Jitter Attenuator)**

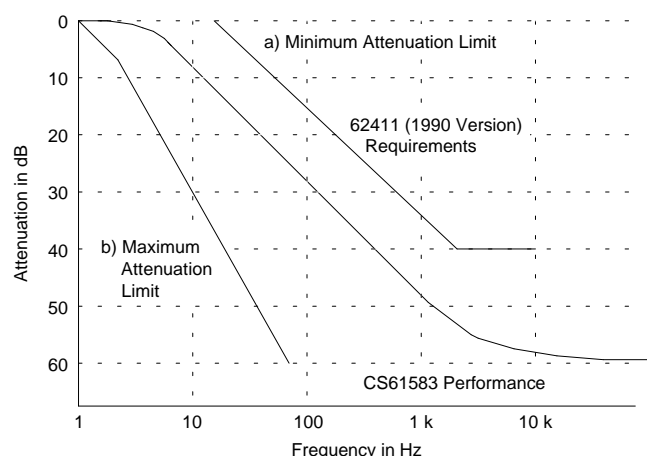
The attenuator consists of a 64-bit FIFO, a narrow-band monolithic PLL, and control logic. Signal jitter is absorbed in the FIFO which is designed to neither overflow nor underflow. If overflow or underflow is imminent, the jitter transfer function is altered to insure that no bit-errors occur. Under this condition, jitter gain may occur and jitter should be attenuated externally in a frame buffer. The jitter attenuator will typically tolerate 43 UIs before the overflow/underflow mechanism occurs. If the jitter attenuator has not had time to "lock" to the aver-

age incoming frequency (e.g. following a device reset) the attenuator will tolerate a minimum of 22 UIs before the overflow/underflow mechanism occurs.

For T1/E1 line cards used in high-speed multiplexers (e.g., SONET and SDH), the jitter attenuator is typically used in the transmit path. The attenuator can accept a transmit clock with gaps  $\leq 28$  UIs and a transmit clock burst rate of  $\leq 8$  MHz.

When the jitter attenuator is in the receive path and loss of signal occurs, the frequency of the last recovered signal is held. When the jitter attenuator is not in the receive path, the last recovered frequency is not held and the output frequency becomes the frequency of the reference clock.

A typical jitter attenuation curve is shown in Figure 9.



**Figure 9. Typical Jitter Transfer Function**

**REFERENCE CLOCK**

The CS61583 requires a reference clock with a minimum accuracy of  $\pm 100$  ppm for T1 and E1 applications. This clock can be either a 1X clock (i.e., 1.544 MHz or 2.048 MHz), or can be a 8X clock (i.e., 12.352 MHz or 16.384 MHz) as selected by the 1XCLK pin. In systems with a

jittered transmit clock, the reference clock should not be tied to the transmit clock and a separate external oscillator should drive the reference clock input. Any jitter present on the reference clock will not be filtered by the jitter attenuator.

**POWER-UP RESET**

On power-up, the device is held in a static state until the power supply achieves approximately 60% of the power supply voltage. When this threshold is crossed, the device waits another 10 ms to allow the power supply to reach operating voltage and then calibrates the transmit and receive circuitry. This initial calibration takes less than 20 ms but can occur only if REFCLK and TCLK are present. The power-up reset performs the same functions as the RESET pin.

**LINE CONTROL AND MONITORING**

Line control and monitoring of the CS61583 is achieved using the control pins. The controls and indications available on the CS61583 are detailed below.

**Line Code Encoder/Decoder**

Coding may be transparent, AMI, B8ZS, or HDB3 and is selected using the CODER1, CODER2, AMI1, and AMI2 pins. In the coder mode, AMI, B8ZS, and HDB3 line codes are available. The input data to the encoder is on TDATA and the output data from the decoder is in NRZ format on RDATA. See Table 4.

<b>CODER[2:1]=0</b>	<b>CODER[2:1]=1</b>
Transparent Mode Enabled and AMI[2:1] Pin(s) Disabled	AMI[2:1]=0 B8ZS/HDB3 Encoder/Decoder Enabled
	AMI[2:1]=1 AMI Encoder/Decoder Enabled

**Table 4. Coder Mode Options**

### ***Alarm Indication Signal***

In coder mode, the TNEG pin becomes the alarm indication signal (AIS) output controlled by the receiver. The receiver detects the AIS condition on observation of 99.9% ones density in a 5.3 ms period ( $< 9$  zeros in 8192 bits) and sets the AIS pin high. The AIS condition is exited when  $\geq 9$  zeros are detected in 8192 bits.

### ***Bipolar Violation Detection***

In coder mode, the RNEG pin becomes the bipolar violation (BPV) strobe output controlled by the receiver. The BPV pin goes high for one RCLK period when a bipolar violation is detected in the received signal. Note that B8ZS or HDB3 zero substitutions are not flagged as bipolar violations when the decoder is enabled.

### ***Loss of Signal***

The loss of signal (LOS) indication is detected by the receiver and reported when the LOS pin is high. Loss of signal is indicated when  $175 \pm 15$  consecutive zeros are received. The LOS condition is exited according to the ANSI T1.231-1993 criteria that requires 12.5% ones density over  $175 \pm 75$  bit periods with no more than 100 consecutive zeros. Note that bit errors may occur at RPOS and RNEG (or RDATA) prior to the LOS indication if the analog input level falls below the receiver sensitivity.

The LOS pin is set high when the device is reset or in powered up and returns low when data is recovered by the receiver.

### ***Transmit All Ones***

Transmit all ones is selected by setting the TAOS pin high. Selecting TAOS causes continuous ones to be transmitted to the line interface on TTIP and TRING at the frequency of REFCLK. In this mode, the transmit data inputs TPOS and TNEG (or TDATA) are ignored. A TAOS overrides the data transmitted to the line interface during local and remote loopbacks.

### ***Local Loopback***

A local loopback is selected by setting the LLOOP pin high. Selecting LLOOP causes the TCLK, TPOS, and TNEG (or TDATA) inputs to be looped back through the jitter attenuator (if enabled) to the RCLK, RPOS, and RNEG (or RDATA) outputs. Data received at the line interface is ignored, but data at TPOS and TNEG (or TDATA) continues to be transmitted to the line interface at TTIP and TRING.

A TAOS request overrides the data transmitted to the line interface during local loopback. Note that simultaneous selection of local and remote loopback modes is not valid.

### ***Remote Loopback***

A remote loopback is selected by setting the RLOOP pin high. Selecting RLOOP causes the data received from the line interface at RTIP and RRING to be looped back through the jitter attenuator (if enabled) and retransmitted on TTIP and TRING. Data transmitted at TPOS and TNEG (or TDATA) is ignored, but data recovered from RTIP and RRING continues to be transmitted on RPOS and RNEG (or RDATA).

Remote loopback is functional if TCLK is absent. A TAOS request overrides the data transmitted to the line interface during a remote loopback. Note that simultaneous selection of local and remote loopback modes is not valid.

### ***Reset Pin***

The CS61583 is continuously calibrated during operation to insure the performance of the device over power supply and temperature. The continuous calibration function eliminates the need to reset the line interface during operation.

A device reset may be selected by setting the RESET pin high for a minimum of 200 ns. The reset function initiates on the falling edge of RESET and takes less than 20 ms to complete. The control logic is initialized and the transmit and

receive circuitry is calibrated if REFCLK and TCLK are present.

**JTAG BOUNDARY SCAN**

Board testing is supported through JTAG boundary scan. Using boundary scan, the integrity of the digital paths between devices on a circuit board can be verified. This verification is supported by the ability to externally set the signals on the digital output pins of the CS61583, and to externally read the signals present on the input pins of the CS61583. Additionally, the manufacturer ID, part number and revision of the CS61583 can be read during board test using JTAG boundary scan.

As shown in Figure 10, the JTAG hardware consists of data and instruction registers plus a Test Access Port (TAP) controller. Control of the TAP is achieved through signals applied to the Test Mode Select (J-TMS) and Test Clock ( J-TCK) input pins. Data is shifted into the registers via the Test Data Input (J-TDI) pin, and shifted out of the registers via the Test Data Output (J-TDO) pin. Both J-TDI and J-TDO are clocked at a rate determined by J-TCK. The Instruction register defines which data register is accessed in the

shift operation. Note that if J-TDI is floating, an internal pull-up resistor forces the pin high.

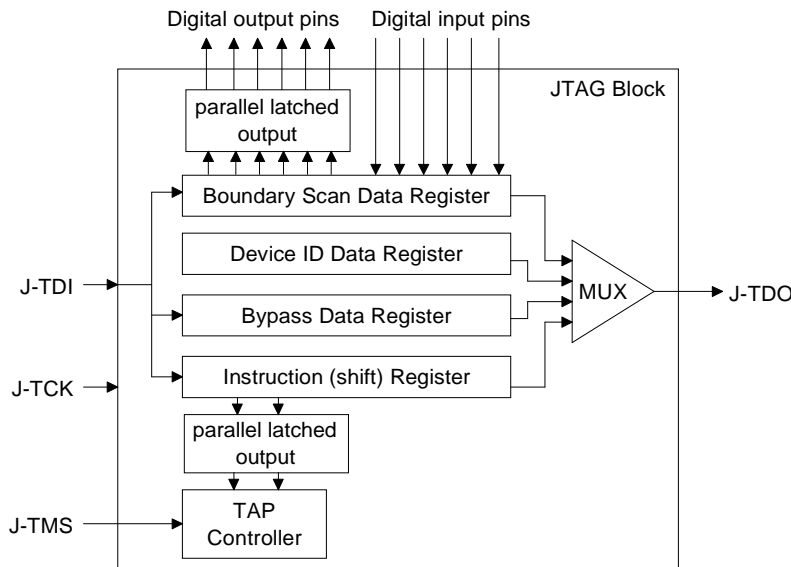
**JTAG Data Registers (DR)**

The test data registers are the Boundary-Scan Register (BSR), the Device Identification Register (DIR), and the Bypass Register (BR).

**Boundary Scan Register:** The BSR is connected in parallel to all the digital I/O pins, and provides the mechanism for applying/reading test patterns to/from the board traces. The BSR is 67 bits long and is initialized and read using the instruction SAMPLE/PRELOAD. The bit ordering for the BSR is the same as the top-view package pin out, beginning with the LOS1 pin and moving counter-clockwise to end with the CODER1 pin as shown in Table 5. Note that the analog, oscillator, power, ground, CLKE, and ATTEN0 pins are not included as part of the boundary-scan register.

The input pins require one bit in the BSR and only one J-TCK cycle is required to load test data for each input pin.

The output pins have two bits in the BSR to define output high, output low, or high impedance.



**Figure 10. Block Diagram of JTAG Circuitry**

The first bit (shifted in first) selects between an output-enabled state (bit set to 1) or high-impedance state (bit set to 0). The second bit shifted in contains the test data that may be output on the pin. Therefore, two J-TCK cycles are required to load test data for each output pin.

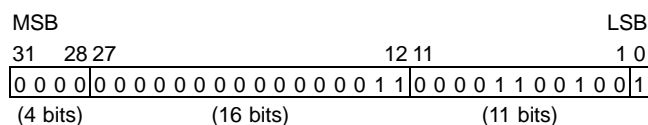
BSR bits	Pin Name	Pad Type
0-2	LOS1	bi-directional <sup>2</sup>
3-5	TNEG1/AIS1	bi-directional
6	TPOS1/TDATA1	input
7	TCLK1	input
8-9	RNEG1/BPV1	output
10-11	RPOS1/RDATA1	output
12-13	RCLK1	output
14-16	ATTEN1	bi-directional <sup>1</sup>
17-19	RLOOP1	bi-directional <sup>1</sup>
20	LLOOP1	input
21-23	LLOOP2	bi-directional <sup>1</sup>
24-26	TAOS1	bi-directional <sup>1</sup>
27-29	TAOS2	bi-directional <sup>1</sup>
30-32	CON01	bi-directional <sup>1</sup>
33-35	CON02	bi-directional <sup>1</sup>
36-38	CON11	bi-directional <sup>1</sup>
39-41	CON12	bi-directional <sup>1</sup>
42-44	CON21	bi-directional <sup>1</sup>
45	CON22	input
46-48	AMI1	bi-directional <sup>1</sup>
49-50	RCLK2	output
51-52	RPOS2/RDATA2	output
53-54	RNEG2/BPV2	output
55	TCLK2	input
56	TPOS2/TDATA2	input
57-59	TNEG2/AIS2	bi-directional
60-62	LOS2	bi-directional <sup>2</sup>
63	AMI2	input
64	CODER2	input
65	RLOOP2	input
66	CODER1	input

1. Configure pad as an input.
2. Configure pad as an output.

**Table 5. Boundary Scan Register**

The bi-directional pins have three bits in the BSR to define input, output high, output low, or high impedance. The first bit shifted into the BSR configures the output driver as high-impedance (bit set to 0) or active (bit set to 1). The second bit shifted into the BSR sets the output value when the first bit is 1. The third bit captures the value of the pin. This pin may have its value set externally as an input (if the first bit is 0) or set internally as an output (if the first bit is 1). To configure a pad as an input, the J-TDI pattern is 0X0. To configure a pad as an output, the J-TDI pattern is 1X1. Therefore, three J-TCK cycles are required to load test data for each bi-directional pin.

Device Identification Register: The DIR provides the manufacturer, part number, and version of the CS61583. This information can be used to verify that the proper version or revision number has been used in the system under test. The DIR is 32 bits long and is partitioned as shown in figure 11.



BIT #(s)	FUNCTION	Total Bits
31-28	Version number	4
27-12	Part Number	16
11-1	Manufacturer Number	11
0	Constant Logic '1'	1

**Figure 11. Device Identification Register**

Data from the DIR is shifted out to J-TDO LSB first.

Bypass Register: The Bypass register consists of a single bit, and provides a serial path between J-TDI and J-TDO, bypassing the BSR. This allows bypassing specific devices during certain board-level tests. This also reduces test access times by reducing the total number of shifts required from J-TDI to J-TDO.



***JTAG Instructions and Instruction Register (IR)***

The instruction register (2 bits) allows the instruction to be shifted into the JTAG circuit. The instruction selects the test to be performed or the data register to be accessed or both. The valid instructions are shifted in LSB first and are listed below:

IR CODE	INSTRUCTION
00	EXTEST
01	SAMPLE/PRELOAD
10	IDCODE
11	BYPASS

**EXTEST Instruction:** The EXTEST instruction allows testing of off-chip circuitry and board-level interconnect. EXTEST connects the BSR to the J-TDI and J-TDO pins. The normal path between the CS61583 logic and I/O pins is broken. The signals on the output pins are loaded from the BSR and the signals on the input pins are loaded into the BSR.

**SAMPLE/PRELOAD Instruction:** The SAMPLE/PRELOAD instructions allows scanning of the boundary-scan register without interfering with the operation of the CS61583. This instruction connects the BSR to the J-TDI and J-TDO pins. The normal path between the CS61583 logic and its I/O pins is maintained. The signals on the I/O pins are loaded into the BSR. Additionally, this instruction can be used to latch values into the digital output pins.

**IDCODE Instruction:** The IDCODE instruction connects the device identification register to the J-TDO pin. The IDCODE instruction is forced into the instruction register during the Test-Logic-Reset controller state. The default instruction is IDCODE after a device reset.

**BYPASS Instruction:** The BYPASS instruction connects the minimum length bypass register between the J-TDI and J-TDO pins and allows data to be shifted in the Shift-DR controller state.

***Internal Testing Considerations***

Note that the INTEST instruction is not supported because of the difficulty in performing significant internal tests using JTAG.

The one test that could be easily performed using an arbitrary clock rate on TCLK and REFCLK is a local loopback with jitter attenuator disabled. However, this test provides limited fault coverage and is only useful in determining if the device had been catastrophically destroyed. Alternatively, catastrophic destruction of the device and/or surrounding board traces can be detected using EXTEST. Therefore, the INTEST instruction provides limited testing capability and was not included in the CS61583.

***JTAG TAP Controller***

Figure 12 shows the state diagram for the TAP state machine. A description of each state follows. Note that the figure contains two main branches to access either the data or instruction registers. The value shown next to each state transition in this figure is the value present at J-TMS at each rising edge of J-TCK.

***Test-Logic-Reset State***

In this state, the test logic is disabled to continue normal operation of the device. During initialization, the CS61583 initializes the instruction register with the IDCODE instruction.

Regardless of the original state of the controller, the controller enters the Test-Logic-Reset state when the J-TMS input is held high for at least five rising edges of J-TCK. The controller remains in this state while J-TMS is high. The CS61583 processor automatically enters this state at power-up.

***Run-Test/Idle State***

This is a controller state between scan operations. Once in this state, the controller remains in the state as long as J-TMS is held low. The

instruction register and all test data registers retain their previous state. When J-TMS is high and a rising edge is applied to J-TCK, the controller moves to the Select-DR state.

**Select-DR-Scan State**

This is a temporary controller state. The test data register selected by the current instruction retains its previous state. If J-TMS is held low and a rising edge is applied to J-TCK when in this state, the controller moves into the Capture-DR state and a scan sequence for the selected test data register is initiated. If J-TMS is held high and a rising edge applied to J-TCK, the controller moves to the Select-IR-Scan state.

The instruction does not change in this state.

**Capture-DR State**

In this state, the Boundary Scan Register captures input pin data if the current instruction is EXTEST or SAMPLE/PRELOAD. The other test data registers, which do not have parallel input, are not changed.

The instruction does not change in this state.

When the TAP controller is in this state and a rising edge is applied to J-TCK, the controller enters the Exit1-DR state if J-TMS is high or the Shift-DR state if J-TMS is low.

**Shift-DR State**

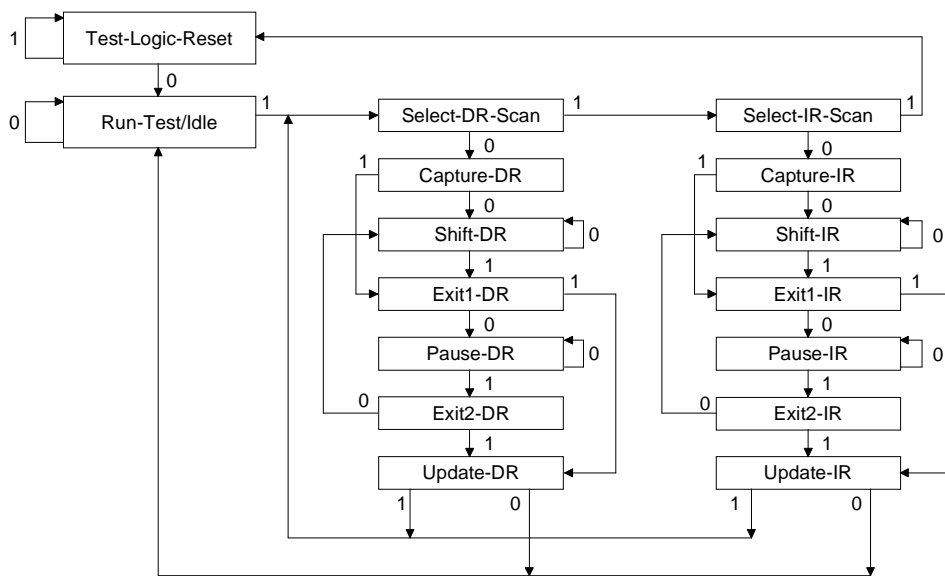
In this controller state, the test data register connected between J-TDI and J-TDO as a result of the current instruction shifts data on stage toward its serial output on each rising edge of J-TCK.

The instruction does not change in this state.

When the TAP controller is in this state and a rising edge is applied to J-TCK, the controller enters the Exit1-DR state if J-TMS is high or remains in the Shift-DR state if J-TMS is low.

**Exit1-DR State**

This is a temporary state. While in this state, if J-TMS is held high, a rising edge applied to J-TCK causes the controller to enter the Update-DR state, which terminates the scanning process. If J-TMS is held low and a rising edge is applied to J-TCK, the controller enters the Pause-DR state.



**Figure 12. TAP Controller State Diagram**

The test data register selected by the current instruction retains its previous value during this state. The instruction does not change in this state.

### ***Pause-DR State***

The pause state allows the test controller to temporarily halt the shifting of data through the test data register in the serial path between J-TDI and J-TDO. For example, this state could be used to allow the tester to reload its pin memory from disk during application of a long test sequence.

The test data register selected by the current instruction retains its previous value during this state. The instruction does not change in this state.

The controller remains in this state as long as J-TMS is low. When J-TMS goes high and a rising edge is applied to J-TCK, the controller moves to the Exit2-DR state.

### ***Exit2-DR State***

This is a temporary state. While in this state, if J-TMS is held high, a rising edge applied to J-TCK causes the controller to enter the Update-DR state, which terminates the scanning process. If J-TMS is held low and a rising edge is applied to J-TCK, the controller enters the Shift-DR state.

The test data register selected by the current instruction retains its previous value during this state. The instruction does not change in this state.

### ***Update-DR State***

The Boundary Scan Register is provided with a latched parallel output to prevent changes while data is shifted in response to the EXTEST and SAMPLE/PRELOAD instructions. When the TAP controller is in this state and the Boundary Scan Register is selected, data is latched into the

parallel output of this register from the shift-register path on the falling edge of J-TCK. The data held at the latched parallel output changes only in this state.

All shift-register stages in the test data register selected by the current instruction retains their previous value during this state. The instructions does not change in this state.

### ***Select-IR-Scan State***

This is a temporary controller state. The test data register selected by the current instruction retains its previous state. If J-TMS is held low and a rising edge is applied to J-TCK when in this state, the controller moves into the Capture-IR state, and a scan sequence for the instruction register is initiated. If J-TMS is held high and a rising edge is applied to J-TCK, the controller moves to the Test-Logic-Reset state. The instruction does not change in this state.

### ***Capture-IR State***

In this controller state, the shift register contained in the instruction register loads a fixed value of "01" on the rising edge of J-TCK. This supports fault-isolation of the board-level serial test data path.

Data registers selected by the current instruction retain their value during this state. The instructions does not change in this state.

When the controller is in this state and a rising edge is applied to J-TCK, the controller enters the Exit1-IR state if J-TMS is held high, or the Shift-IR state if J-TMS is held low.

### ***Shift-IR State***

In this state, the shift register contained in the instruction register is connected between J-TDI and J-TDO and shifts data one stage towards its serial output on each rising edge of J-TCK.

The test data register selected by the current instruction retains its previous value during this state. The instruction does not change in this state.

When the controller is in this state and a rising edge is applied to J-TCK, the controller enters the Exit1-IR state if J-TMS is held high, or remains in the Shift-IR state if J-TMS is held low.

### ***Exit1-IR State***

This is a temporary state. While in this state, if J-TMS is held high, a rising edge applied to J-TCK causes the controller to enter the Update-IR state, which terminates the scanning process. If J-TMS is held low and a rising edge is applied to J-TCK, the controller enters the Pause-IR state.

The test data register selected by the current instruction retains its previous value during this state. The instruction does not change in this state.

### ***Pause-IR State***

The pause state allows the test controller to temporarily halt the shifting of data through the instruction register.

The test data register selected by the current instruction retains its previous value during this state. The instruction does not change in this state.

The controller remains in this state as long as J-TMS is low. When J-TMS goes high and a rising edge is applied to J-TCK, the controller moves to the Exit2-IR state.

### ***Exit2-IR State***

This is a temporary state. While in this state, if J-TMS is held high, a rising edge applied to J-TCK causes the controller to enter the Update-IR state, which terminates the scanning process. If

J-TMS is held low and a rising edge is applied to J-TCK, the controller enters the Shift-IR state.

The test data register selected by the current instruction retains its previous value during this state. The instruction does not change in this state.

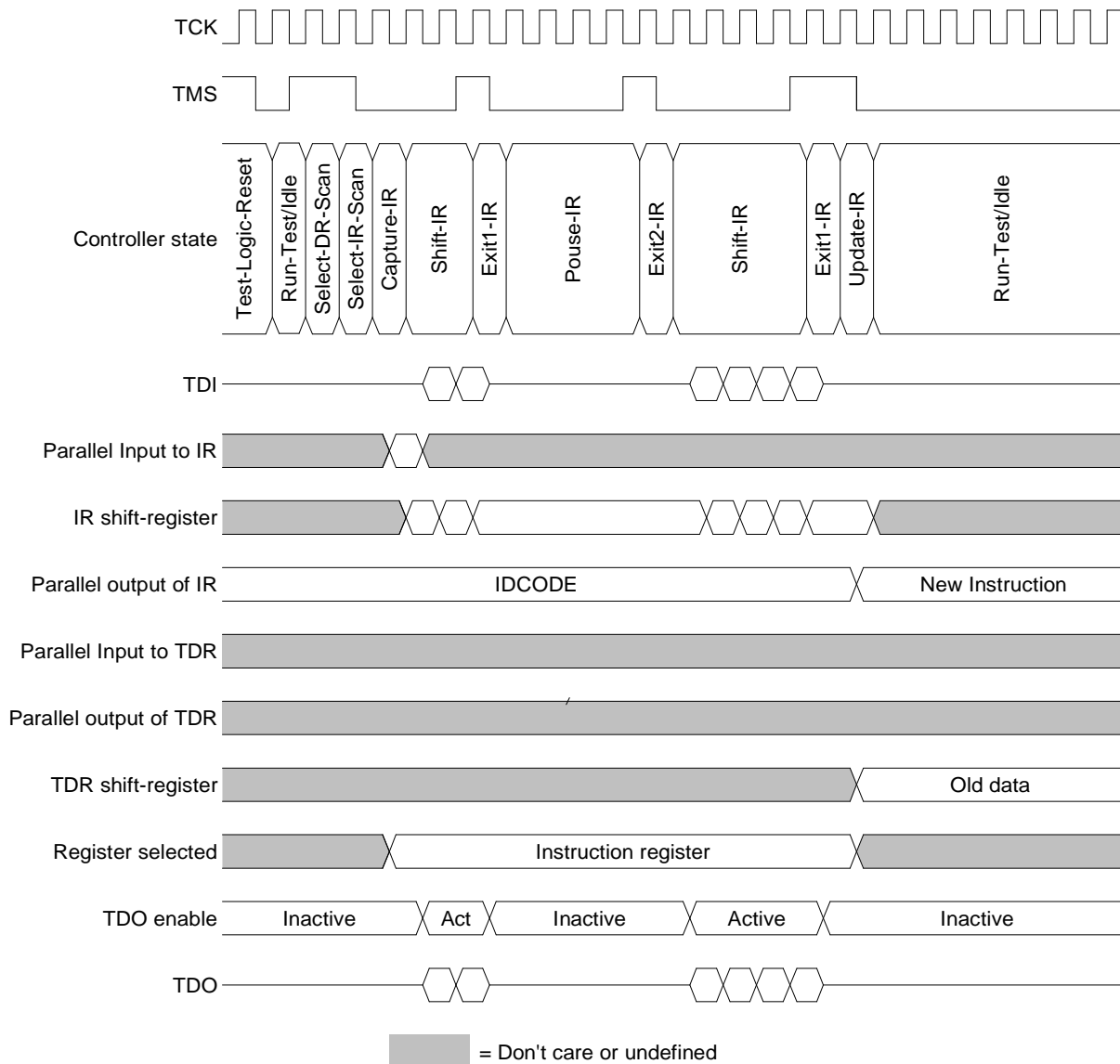
### ***Update-IR State***

The instruction shifted into the instruction register is latched into the parallel output from the shift-register path on the falling edge of J-TCK. When the new instruction has been latched, it becomes the current instruction.

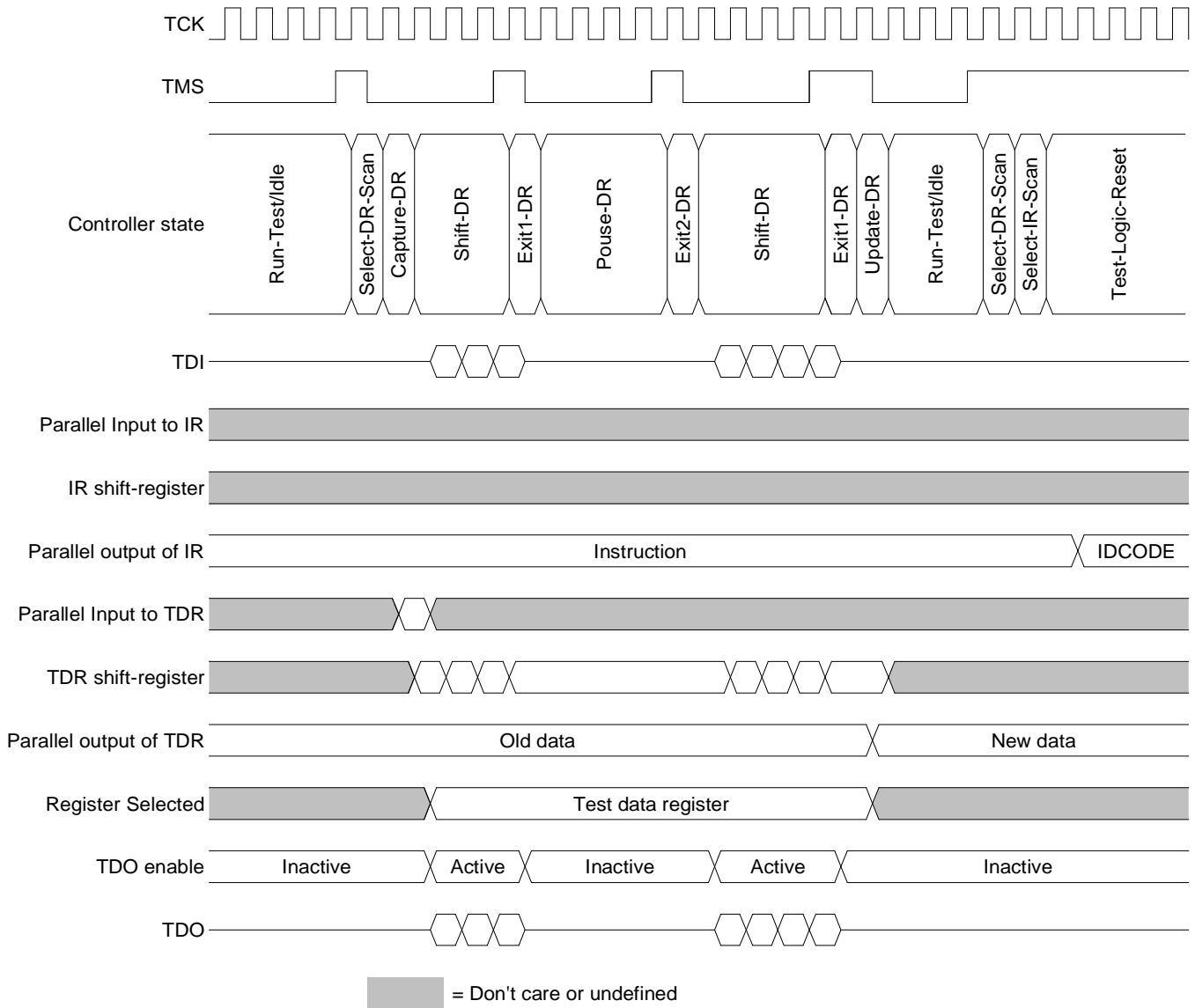
Test data registers selected by the current instruction retain their previous value.

### ***JTAG Application Examples***

Figures 13 and 14 illustrate examples of updating the instruction and data registers during JTAG operation.

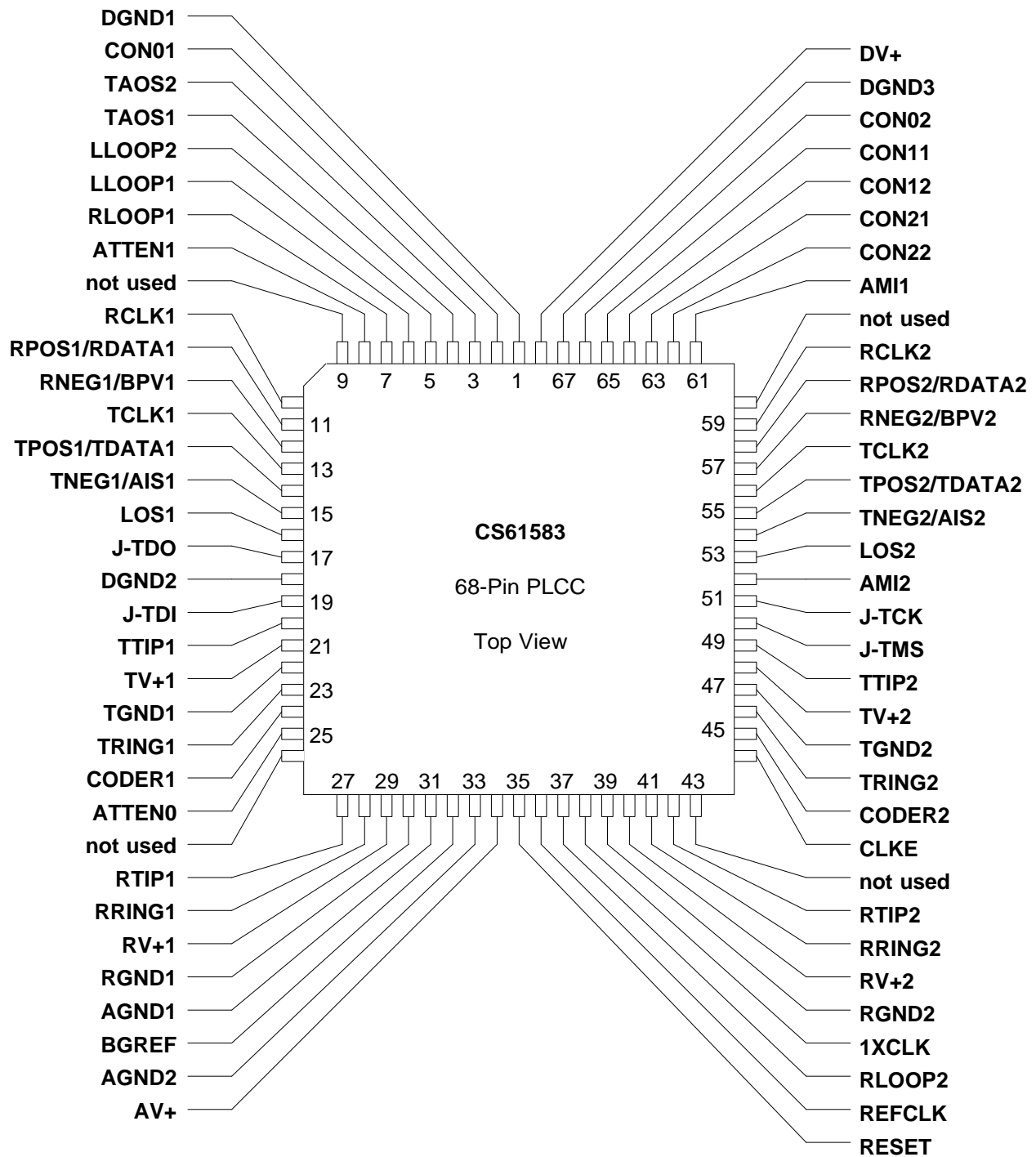


**Figure 13. JTAG Instruction Register Update**

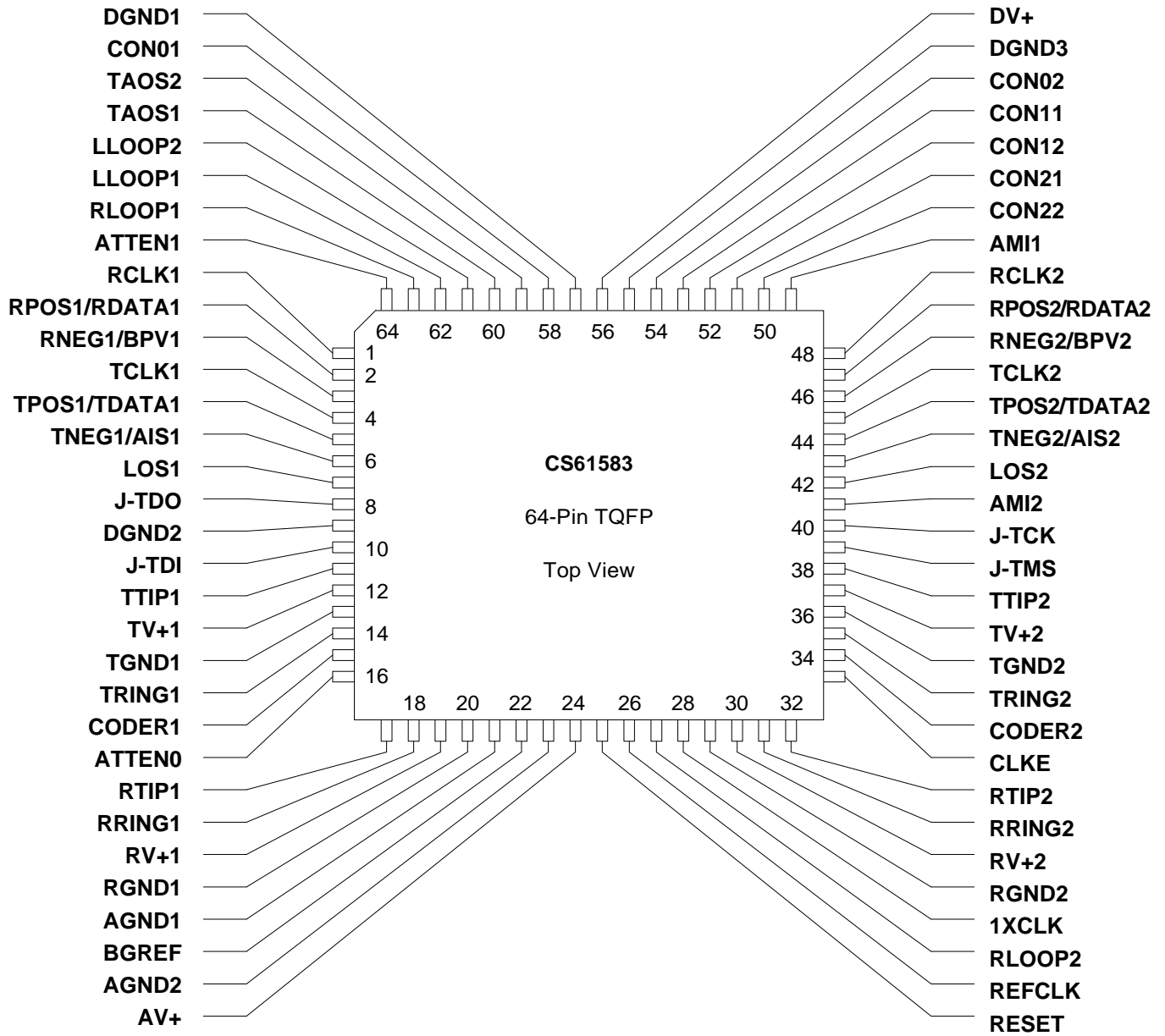


**Figure 14. JTAG Data Register Update**

**PIN DESCRIPTIONS**



Note: Pins labeled as "not used" should be tied to ground.





### Power Supplies

**AGND1, AGND2 : Analog Ground (PLCC pins 31, 33; TQFP pins 21, 23)**

Analog supply ground pins.

**AV+ : Analog Power Supply (PLCC pin 34; TQFP pin 24)**

Analog supply pin for the internal bandgap reference and timing generation circuits.

**BGREF : Bandgap Reference (PLCC pin 32; TQFP pin 22)**

This pin is used by the internal bandgap reference and must be connected to ground by a  $4.99\text{k}\Omega \pm 1\%$  resistor to provide an internal current reference.

**DGND1, DGND2, DGND3 : Digital Ground (PLCC pins 1, 18, 67; TQFP pins 57, 9, 55)**

Power supply ground pins for the digital circuitry of both channels.

**DV+ : Power Supply (PLCC pin 68; TQFP pin 56)**

Power supply pin for the digital circuitry of both channels.

**RGND1, RGND2 : Receiver Ground (PLCC pins 30, 39; TQFP pins 20, 29)**

Power supply ground pins for the receiver circuitry.

**RV+1, RV+2 : Receiver Power Supply (PLCC pins 29, 40; TQFP pins 19, 30)**

Power supply pins for the analog receiver circuitry.

**TGND1, TGND2 : Transmit Ground (PLCC pins 22, 47; TQFP pins 13, 36)**

Power supply ground pins for the transmitter circuitry.

**TV+1, TV+2 : Transmit Power Supply (PLCC pins 21, 48; TQFP pins 12, 37)**

Power supply pins for the analog transmitter circuitry.

### TI/EI Data

**RCLK1, RCLK2 : Receive Clock (PLCC pins 10, 59; TQFP pins 1, 48)****RPOS1, RPOS2 : Receive Positive Data (PLCC pins 11, 58; TQFP pins 2, 47)****RNEG1, RNEG2 : Receive Negative Data (PLCC pins 12, 57; TQFP pins 3, 46)**

The receiver recovered clock and NRZ digital data from RTIP and RRING is output on these pins. The CLKE pin determines the clock edge on which RPOS and RNEG are stable and valid. A positive pulse (with respect to ground) received on RTIP generates a logic 1 on RPOS, and a positive pulse received on RRING generates a logic 1 on RNEG.

**RDATA1, RDATA2 : Receive Data (PLCC pins 11, 58; TQFP pins 2, 47)**

In coder mode (CODER = 1), the decoded digital data stream from RTIP and RRING is output on RDATA in NRZ format. The CLKE pin determines the clock edge on which RDATA is stable and valid.

**RTIP1, RTIP2 : Receive Tip (PLCC pins 27, 42; TQFP pins 17, 32)****RRING1, RRING2 : Receive Ring (PLCC pins 28, 41; TQFP pins 18, 31)**

The receive AMI signal from the line interface is input on these pins. The recovered clock and data are output on RCLK, RPOS, and RNEG (or RDATA).

**TCLK1, TCLK2 : Transmit Clock (PLCC pins 13, 56; TQFP pins 4, 45)**

**TPOS1, TPOS2 : Transmit Positive Data (PLCC pins 14, 55; TQFP pins 5, 44)**

**TNEG1, TNEG2 : Transmit Negative Data (PLCC pins 15, 54; TQFP pins 6, 43)**

The transmit clock and data are input to these pins. The signal is driven to the line interface at TTIP and TRING. Data at TPOS and TNEG are sampled on the falling edge of TCLK. An input at TPOS causes a positive pulse to be transmitted at TTIP and TRING, while an input at TNEG causes a negative pulse to be transmitted at TTIP and TRING.

**TDATA1, TDATA2 : Transmit Positive Data (PLCC pins 14, 55; TQFP pins 5, 44)**

In coder mode (CODER = 1), the un-encoded digital data stream is input on TDATA in NRZ format. Data at TDATA is sampled on the falling edge of TCLK.

**TTIP1, TTIP2 : Transmit Tip (PLCC pins 20, 49; TQFP pins 11, 38)**

**TRING1, TRING2 : Transmit Ring (PLCC pins 23, 46; TQFP pins 14, 35)**

The transmit AMI signal to the line interface is output on these pins. The transmit clock and data are input from TCLK, TPOS, and TNEG (or TDATA).

### Oscillator

**1XCLK : One-times Clock Frequency Select (PLCC pin 38; TQFP pin 28)**

When 1XCLK is set high, REFCLK must be a 1X clock (i.e., 1.544 MHz for T1 or 2.048 MHz for E1 applications). When 1XCLK is set low, REFCLK must be an 8X clock (i.e., 12.352 MHz for T1 or 16.384 MHz for E1 applications).

**REFCLK : External Reference Clock Input (PLCC pin 36, TQFP pin 26)**

Input reference clock for the receive and jitter attenuator circuits. When 1XCLK is high, REFCLK must be a 1X clock (i.e., 1.544 MHz  $\pm$ 100 ppm for T1 applications or 2.048 MHz  $\pm$ 100 ppm for E1 applications). When 1XCLK is set low, REFCLK must be an 8X clock (i.e., 12.352 MHz  $\pm$ 100 ppm for T1 applications or 16.384 MHz  $\pm$ 100 ppm for E1 applications). The REFCLK input also determines the transmission rate when TAOS is asserted.

### Control

**AMI1, AMI2 : Encoder/Decoder Select (PLCC pins 61, 52; TQFP pins 49, 41)**

Setting AMI low enables the B8ZS or HDB3 zero substitution in the transmitter encoders and receiver decoders. Setting AMI high enables AMI encoders and decoders. The AMI pins are enabled by setting the corresponding CODER pin high.

**ATTEN0, ATTEN1 : Jitter Attenuator Select (PLCC pins 25, 8; TQFP pins 16, 64)**

Selects the jitter attenuation path for both channels (transmit/receive/neither).

**CLKE : Clock Edge (PLCC pin 44; TQFP pin 33)**

Controls the polarity of the recovered clock RCLK. When CLKE is high, RPOS and RNEG are valid on the falling edge of RCLK. When CLKE is low, RPOS and RNEG are valid on the rising edge of RCLK.

**CODER1, CODER2 : Coder Mode Configuration (PLCC pins 24, 45; TQFP pins 15, 34)**

Setting CODER high causes the Coder Mode to be enabled. In Coder Mode, the transmit and receive data appears in NRZ format on TDATA and RDATA, respectively. These pins also enable the corresponding AMI pin.

**CON01, CON11, CON21, : Configuration Selection****CON02, CON12, CON22 : (PLCC pins 2, 65, 63, 66, 64, 62; TQFP pins 58, 53, 51, 54, 52, 50)**

These pins configure the transmitter (pulse shape, pulse width, pulse amplitude, and driver impedance) receiver (slicing level), and coder (HDB3 vs B8ZS). The CONx1 pins control channel 1 and the CONx2 pins control channel 2. Both channels must be configured to operate at the same data rate on the line interface (both T1 or both E1).

**LLOOP1, LLOOP2 : Local Loopback (PLCC pins 6, 5; TQFP pins 62, 61)**

A local loopback is enabled when LLOOP is high. During local loopback, the TCLK, TPOS/TNEG (or TDATA) inputs are looped back through the jitter attenuator (if enabled) to the RCLK, RPOS/RNEG (or RDATA) outputs. The data at TPOS/TNEG continues to be transmitted to the line interface unless overridden by a TAOS request. The inputs at RTIP and RRING are ignored.

**RESET : Reset (PLCC pin 35; TQFP pin 25)**

A device reset is selected by setting the RESET pin high for a minimum of 200 ns. The reset function initiates on the falling edge of RESET and requires less than 20 ms to complete. The control logic is initialized and LOS is set high.

**RLOOP1, RLOOP2 : Remote Loopback (PLCC pins 7, 37; TQFP pins 63, 27)**

A remote loopback is selected when RLOOP is high. The data received from the line interface at RTIP and RRING is looped back through the jitter attenuator (if enabled) and retransmitted on TTIP and TRING. Data recovered from RTIP and RRING continues to be transmitted on RPOS/RNEG (or RDATA). Data input on TPOS/TNEG (or TDATA) is ignored. A TAOS request overrides the data transmitted at TTIP and TRING.

**TAOS1, TAOS2 : Transmit All Ones Select (PLCC pins 4, 3; TQFP pins 60, 59)**

Setting TAOS high causes continuous ones to be transmitted at the line interface on TTIP and TRING at the frequency determined by REFCLK.

**Status****AIS1, AIS2 : Alarm Indication Signal (PLCC pins 15, 54; TQFP pins 6, 43)**

The AIS indication goes high when the receiver detects 99.9% ones density in a 5.3 ms period (< 9 zeros in 8192 bits). The AIS indication returns low when the receiver detects  $\geq 9$  zeros in 8192 bits.

**BPV1, BPV2 : Bipolar Violation (PLCC pins 12, 57; TQFP pins 3, 46)**

The BPV indication goes high for one RCLK bit period when a bipolar violation is detected in the received signal. Bipolar violations caused by B8ZS (or HDB3) zero substitutions are not flagged by the BPV pin if the coder mode is enabled.

**LOS1, LOS2 : Loss of Signal (PLCC pins 16, 53; TQFP pins 7, 42)**

The LOS indication goes high when  $175 \pm 15$  consecutive zeros are received on the line interface. The LOS indication returns low when a minimum 12.5% ones density signal over  $175 \pm 75$  bit periods with no more than 100 consecutive zeros is received.

***Test*****J-TCK : JTAG Test Clock (PLCC pin 51; TQFP pin 40)**

Data on pins J-TDI and J-TDO is valid on the rising edge of J-TCK. When J-TCK is stopped low, all JTAG registers remain unchanged.

**J-TMS : JTAG Test Mode Select (PLCC pin 50; TQFP pin 39)**

An active high signal on J-TMS enables the JTAG serial port. This pin has an internal pull-up resistor.

**J-TDI : JTAG Test Data In (PLCC pin 19; TQFP pin 10)**

JTAG data is shifted into the device on this pin. This pin has an internal pull-up resistor. Data must be stable on the rising edge of J-TCK.

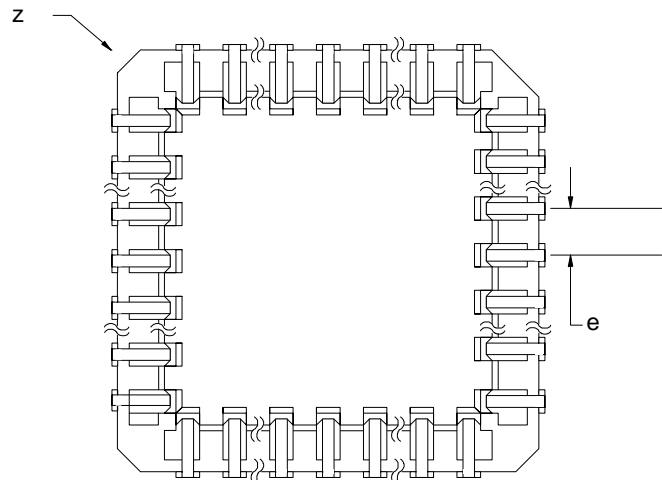
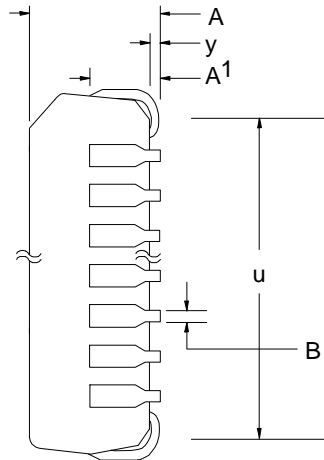
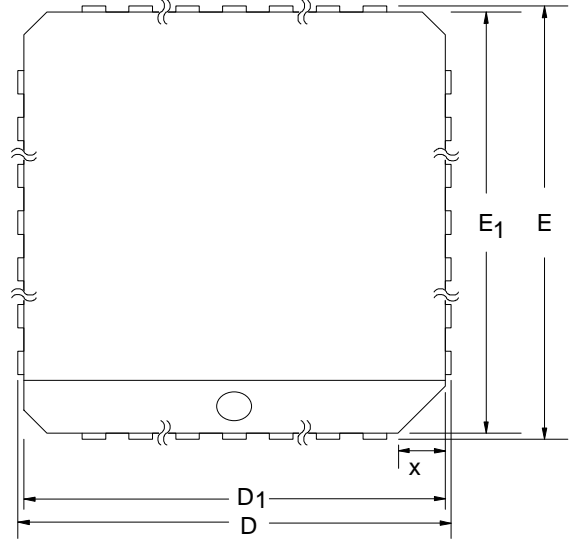
**J-TDO : JTAG Test Data Out (PLCC pin 17; TQFP pin 8)**

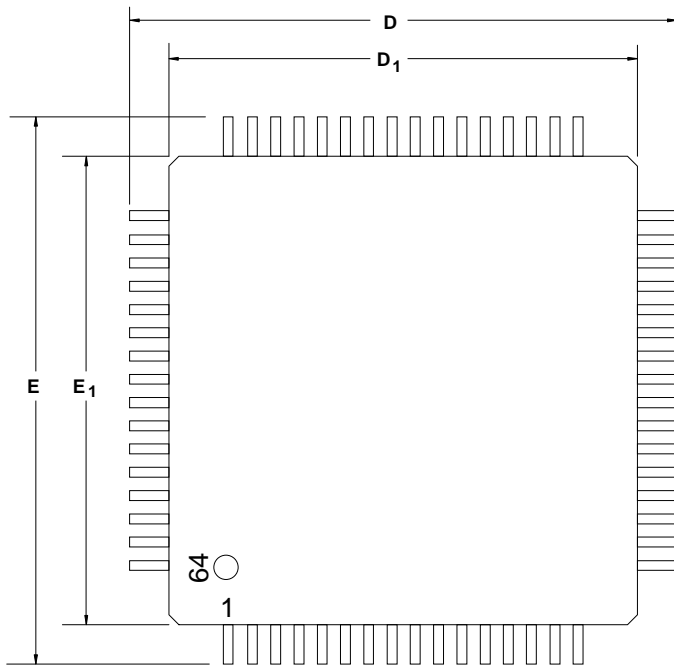
JTAG data is shifted out of the device on this pin. This pin is active only when JTAG testing is in progress. J-TDO will be updated on the falling edge of J-TCK.

**PHYSICAL DIMENSIONS**

68 pin PLCC				
DIM	MILLIMETERS		INCHES	
	MIN	MAX	MIN	MAX
A	4.20	5.08	.165	.200
A <sub>1</sub>	2.29	3.30	.090	.130
B	0.38	0.53	.015	.021
D	24.79	25.30	.976	.996
D <sub>1</sub>	24.13	24.38	.950	.960
E	24.79	25.30	.976	.996
E <sub>1</sub>	24.13	24.38	.950	.960
e	1.27		.050	
u	23.37	23.62	.920	.930
x	1.067	1.219	.042	.048
y	.51		.020	
z	.51 x 45° x 3		.02 x 45° x 3	

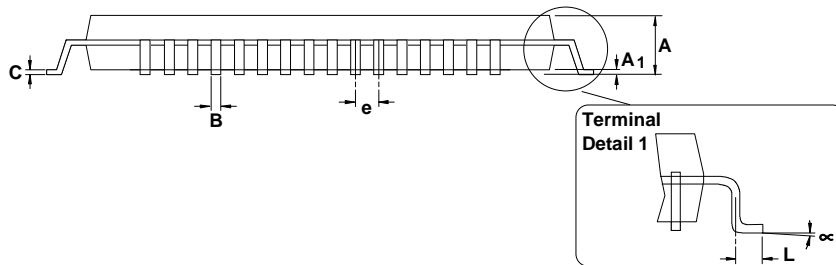
68 pin PLCC



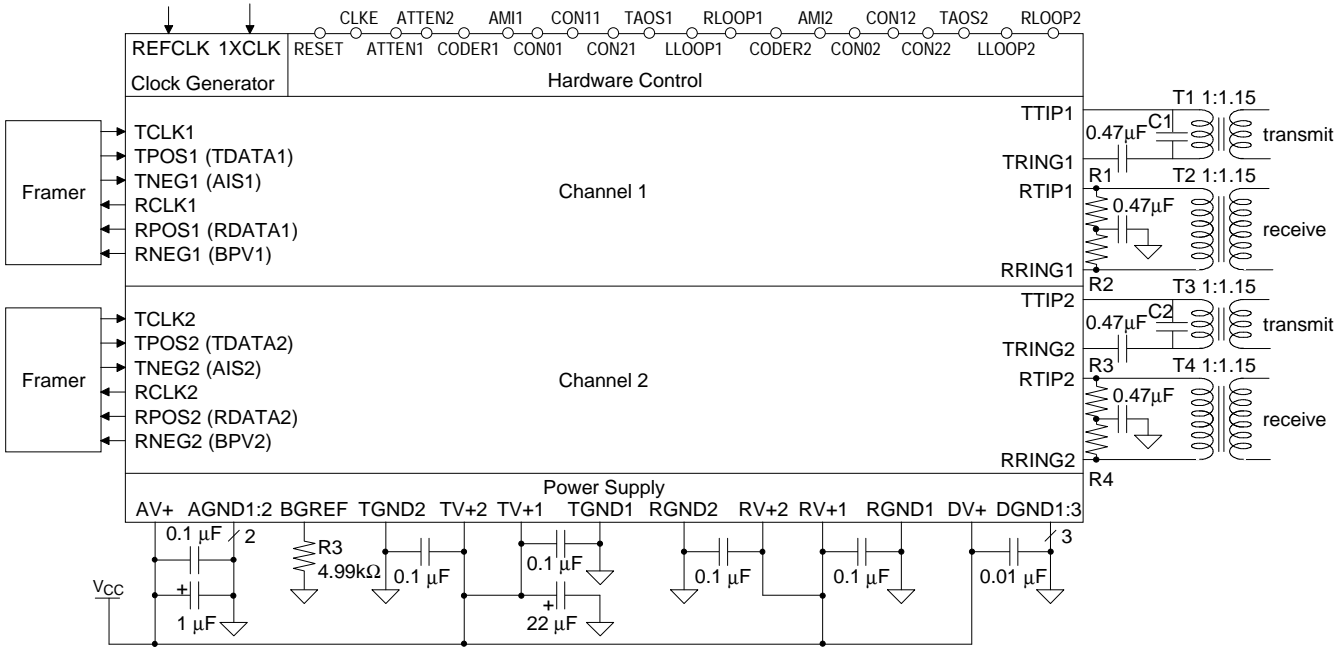


**64-Pin  
TQFP**

DIM	MILLIMETERS		INCHES	
	MIN	MAX	MIN	MAX
A	-	1.66	-	0.068
A <sub>1</sub>	0.00	-	0.00	-
B	0.14	0.26	0.006	0.010
C	0.077	0.177	0.003	0.007
D	11.70	12.30	0.461	0.484
D <sub>1</sub>	10.00	10.00	0.394	0.394
E	11.70	12.30	0.461	0.484
E <sub>1</sub>	10.00	10.00	0.394	0.394
e	0.40	0.60	0.016	0.024
L	0.35	0.70	0.014	0.028
∞	0°	12°	0°	12°



**APPLICATIONS**



**Figure A1. Typical Connection Diagram**

Data Rate (MHz)	REFCLK Frequency (MHz)		Cable (Ω)	R1-R4 (Ω)	C1-C2 (pF)
	1XCLK = 1	1XCLK = 0			
1.544	1.544	12.352	100	38.3	220
2.048	2.048	16.384	75	28.7	470
			120	45.3	220

**Table A1. CS61583 External Components**

**Line Interface**

Figure A1 illustrates a typical connection diagram and Table A1 lists the external components that are required in T1 and E1 applications.

In the transmit line interface circuitry, capacitors C1 and C2 provide transmitter return loss. The 0.47 μF capacitor in series with the transformer primary prevents output stage imbalances from producing a DC current through the transformer that might saturate the transformer and result in an output level offset.

In the receive line interface circuitry, resistors R1-R4 provide receive impedance matching and receiver return loss. The 0.47 μF capacitor to ground provides the necessary differential input voltage reference for the receiver.

**Power Supply**

As shown in Figure A1, the CS61583 operates from a 5.0 Volt supply. Separate analog and digital power supply and ground pins provide internal isolation. The TGND, RGND, and DGND ground pins must not be more negative than AGND. It is recommended that all of the supply pins be connected together at the device. A 4.99kΩ ±1%

resistor must be connected from BGREF to ground to provide an internal current reference.

De-coupling and filtering of the power supplies is crucial for the proper operation of the analog circuits. A capacitor should be connected between each supply and its respective ground. For capacitors smaller than 1  $\mu$ F, use mylar or ceramic capacitors and place them as close as possible to their respective power supply pins. Wire-wrap bread boarding of the line interface is not recommended because lead resistance and inductance defeat the function of the de-coupling capacitors.

***Crystal Oscillator Specifications***

When a reference clock signal is not available, a CMOS crystal oscillator operating at either the 1X or 8X rate can be connected at the REFCLK pin. The oscillator must have a minimum symmetry of 40-60% and minimum stability of  $\pm 100$  ppm for T1 and E1 applications. Based on these specifications, some suggested crystal oscillators for use with the CS61583 are shown in Table A2.

Manufacturer	Part Number	Contact Number
Comclok	CT31CH	(800) 333-9825
CTS	CXO-65HG-5-I	(815) 786-8411
M-tron	MH26TAD	(800) 762-8800
SaRonix	NTH250A	(800) 227-8974

Notes:

Frequency tolerances are  $\pm 32$  ppm with a -40 to +85  $^{\circ}$ C operating temperature range.

All are 8-pin DIP packages and can be tristated.

**Table A2. Suggested Crystal Oscillators**

***Transformers***

Recommended transformer specifications are shown in Table A3. Based on these specifications, the transformers recommended for use with the CS61583 are listed in Table A4.

Turns Ratio	1:1.15 step-up transmit 1:1.15 step-down receive
Primary inductance	1.5 mH min at 772 kHz
Primary leakage inductance	0.3 $\mu$ H max at 772 kHz with secondary shorted
Secondary leakage inductance	0.4 $\mu$ H max at 772 kHz
Interwinding capacitance	18 pF max, primary to secondary
ET-constant	16 V- $\mu$ s min

**Table A3. Transformer Specifications**

***Designing for AT&T 62411***

For additional information on the requirements of AT&T 62411 and the design of an appropriate system synchronizer, refer to the Crystal Semiconductor Application Notes "AT&T 62411 Design Considerations - Jitter and Synchronization" and "Jitter Testing Procedures for Compliance with AT&T 62411."

***Line Protection***

Secondary protection components can be added to the line interface circuitry to provide lightning surge and AC power-cross immunity. For additional information on the different electrical safety standards and specific application circuit recommendations, refer to the Crystal Semiconductor Application Note "Secondary Line Protection for T1 and E1 Line Cards."



Turns Ratio	Manufacturer	Part Number	Package Type
1:1.15	Pulse Engineering	PE-65388	1.5 kV through-hole, single
		PE-65770	1.5 kV through-hole, single extended temperature
		PE-65838	3.0 kV through-hole, single extended temperature
		PE-68674	1.5 kV surface-mount, dual extended temperature
		PE-65870	1.5 kV surface-mount, dual
	Schott	67124840	1.5 kV through-hole, single extended temperature
	Valor	ST5112	2.0 kV surface mount, dual

### Schematic & Layout Review Service

Confirm Optimum  
Schematic & Layout  
Before Building Your Board.

For Our Free Review Service  
Call Applications Engineering.



Call : ( 5 1 2 ) 4 4 5 - 7 2 2 2

## Dual Line Interface Evaluation Board

### Features

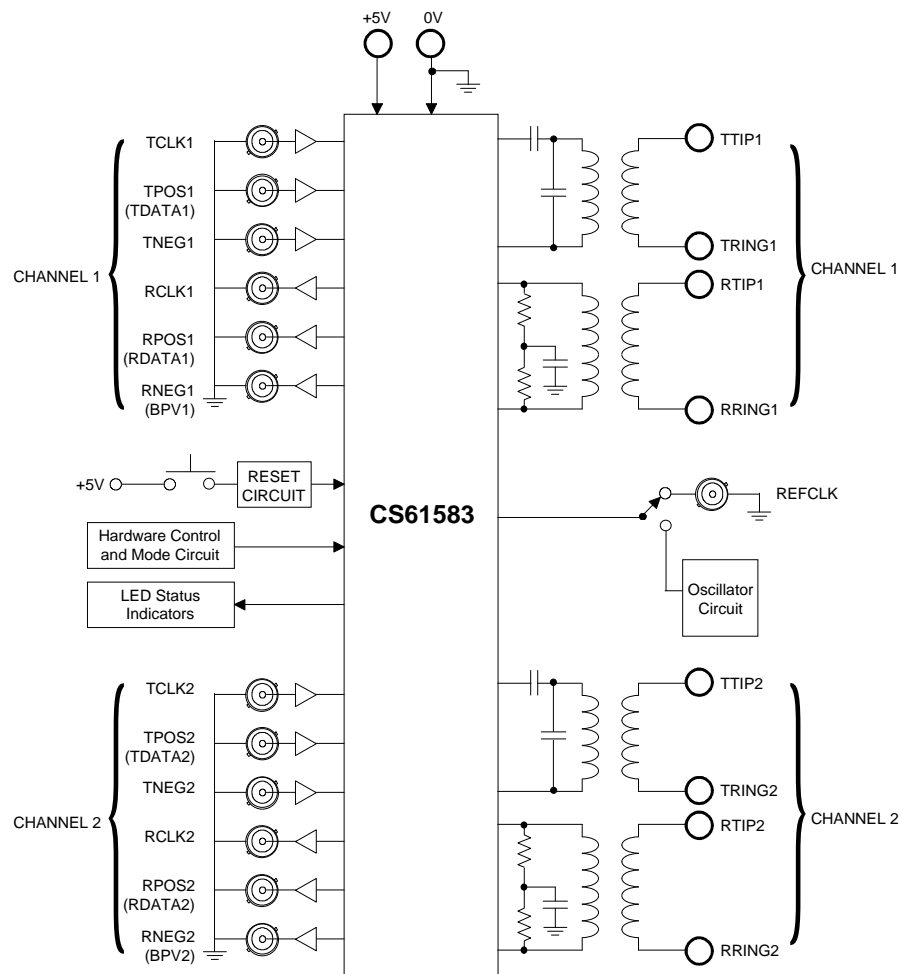
- Socketed CS61583 Dual Line Interface
- All Required Components for CS61583 Evaluation
- Locations to Evaluate Protection Circuitry
- LED Status Indications for Alarm Conditions
- Control of Enhanced Hardware Options

### General Description

The evaluation board includes a socketed CS61583 dual line interface device and all support components necessary for evaluation. The board is powered by an external +5 Volt supply.

The board may be configured for 100Ω twisted-pair T1, 75Ω coax E1, or 120Ω twisted-pair E1 operation. Binding posts and bantam jacks are provided for line interface connections. Several BNC connectors provide clock and data I/O at the system interface. Reference timing may be derived from a crystal oscillator or an external reference clock. Four LED indicators monitor device alarm conditions.

**ORDERING INFORMATION: CDB61583**



## POWER SUPPLY

As shown on the evaluation board schematic in Figures 1-5, power is supplied to the board from an external +5 Volt supply connected to the two binding posts labeled V+ and GND. Zener diode Z1 protects the components on the board from reversed supply connections and over-voltage damage. Capacitor C16 provides power supply decoupling and ferrite bead L1 isolates the CS61583 and buffer supplies. Both sides of the evaluation board contain extensive areas of ground plane to insure optimum performance.

Capacitors C3, C5-C8, C13, C18, and C38 provide power supply decoupling for the CS61583. The BGREF pin is pulled down through resistor R10 to provide an internal current reference. The buffers are decoupled using capacitors C9, C15, and C19. Ferrite beads L2-L4 help reduce the power supply noise that is coupled from the buffers to the power supply.

## BOARD CONFIGURATION

The evaluation board is based on the CDB61584 used to evaluate the CS61584 dual LIU optimized for Host mode applications. Because the CS61583 is optimized for Hardware mode applications, slide switch SW6 must be placed in the "HW" position to set the AGND1 pin of the CS61583 to a logic 0. In addition, the host processor interface appearing at J26 is not used on the CDB61583.

The evaluation board is configured using DIP switches SW2, SW3, and SW4. Because the evaluation board is based on the CDB61584 design, switches SW2, SW3, and SW4 are relabeled with white stickers. These switches establish the digital control inputs for both line interface channels. Closing a DIP switch towards the label sets the CS61583 control pin of the same name to a logic 1. All switch inputs are pulled-down using resistor networks RP2-RP5.

The CDB61583 switch functions are listed below:

- TAOS1, TAOS2: transmit all ones;
- LLOOP1, LLOOP2: local loopback;
- RLOOP1, RLOOP2: remote loopback;
- CODER1, CODER2: encoder/decoder control;
- ATTEN0, ATTEN1: jitter attenuator selection;
- CLKE: RCLK edge polarity;
- 1XCLK: clock frequency selection;
- AMI1, AMI2: encoder/decoder control;
- CONx1, CONx2: line configuration settings.

A jumper must be installed on header J10 to enable RLOOP2 functionality.

## Alarm Indications

The LOS1 and LOS2 LED indicators illuminate when the line interface receiver has detected a loss of signal. Headers J7 and J13 must be jumpered in the "TNEG" position to provide connectivity to the BNC input when the coder mode is disabled ( $\text{CODER}(1,2) = 0$ ).

The AIS alarm condition is provided when the coder mode is enabled ( $\text{CODER}(1,2) = 1$ ) and headers J7 and J13 are jumpered in the "AIS" position. The AIS1 and AIS2 LED indicators illuminate when the line interface receiver has detected the all-ones receive input signal. Resistors R26 and R27 pull-down the TNEG(1,2) inputs when coder mode is disabled but headers J7 and J13 are jumpered in the "AIS" position.

## Manual Reset

A momentary contact switch SW1 provides a manual reset by forcing the RESET pin of the CS61583 to a logic 1. Although the transmit and receive circuitry are continuously calibrated, the

reset can be used to initialize the control logic. Both channels are powered up after exiting reset.

## TRANSMIT CIRCUIT

The transmit clock and data signals are supplied on BNC inputs labeled TCLK(1,2), TPOS(1,2), and TNEG(1,2). When the coder mode is disabled, data is supplied on the TPOS(1,2) and TNEG(1,2) BNC inputs in RZ format. When the coder mode enabled, data is supplied on the TDATA(1,2) BNC input in NRZ format and the TNEG(1,2) BNC input may be used to indicate the AIS alarm condition as described in the Board Configuration section.

The transmitter output is transformer coupled to the line interface through 1:1.15 step-up transformers T1 and T4. The signal is available at either the TTIP(1,2) and TRING(1,2) binding posts or the TX(1,2) bantam jacks.

Capacitors C2 and C11 prevent output stage imbalances from producing a DC current that may saturate the transformer and result in an output level offset. Capacitors C1 and C12 provide transmitter return loss and are socketed so the value may be changed according to the application. A 220 pF capacitor is required for 100 $\Omega$  twisted-pair T1 or 120 $\Omega$  twisted-pair E1 applications. A 470 pF capacitor is required for 75 $\Omega$  coax E1 applications. These capacitors are included with the evaluation board.

Optional diode locations D6-D9 and D10-D13 and optional resistor locations R8-R9 and R18-R19 provide test locations to evaluate transmit line interface protection circuitry.

## RECEIVE CIRCUIT

The receive signal is input at either the RTIP(1,2) and RRING(1,2) binding posts or the RX(1,2) bantam jacks. The receive signal is

transformer coupled to the CS61583 through 1:1.15 step-down transformers T2 and T3.

The receive line is terminated by resistors R3-R4 and R14-R15 to provide impedance matching and receiver return loss. They are socketed so the values may be changed according to the application. The evaluation board is supplied from the factory with 38.3 $\Omega$  resistors for terminating 100 $\Omega$  twisted-pair T1 lines, 45.3 $\Omega$  resistors for terminating 120 $\Omega$  twisted-pair E1 lines, and 28.7 $\Omega$  resistors for terminating 75 $\Omega$  coaxial E1 lines. Capacitors C4 and C10 provide a differential input voltage reference.

Optional resistor locations R1-R2, R12-R13, R16-R17, and R24-R25 provide test locations to evaluate receive line interface protection circuitry.

The recovered clock and data signals are available on BNC outputs labeled RCLK(1,2), RPOS(1,2), and RNEG(1,2). When the coder mode is disabled, data is available on the RPOS(1,2) and RNEG(1,2) BNC outputs in RZ format. When the coder mode is enabled, data is available on the RDATA(1,2) BNC output in NRZ format and bipolar violations are reported on BPV(1,2).

## REFERENCE CLOCK

The CDB61583 requires a T1 or E1 reference clock for operation. This clock may operate at either a 1-X rate (1.544 MHz or 2.048 MHz) or an 8-X rate (12.352 MHz or 16.384 MHz) and can be supplied by either a crystal oscillator or an external reference. The evaluation board is supplied from the factory with two crystal oscillators for T1 and E1 operation.

## Crystal Oscillator

A crystal oscillator may be inserted at socket U4 in the orientation indicated by the silkscreen. Header J14 must be jumpered in the "OSC" position to provide connectivity to the REFCLK pin of the CS61583. The SW2 switch position labeled "1XCLK" must be open (logic 0) for 8-X clock operation or closed (logic 1) for 1-X clock operation.

## External Reference

An external reference may be provided at the REFCLK BNC input. Header J14 must be jumpered in the "REFCLK" position to provide connectivity to the REFCLK pin of the CS61583. The SW2 switch position labeled "1XCLK" must be open (logic 0) for 8-X clock operation or closed (logic 1) for 1-X clock operation.

## BUFFERING

Buffers U2 and U3 provide additional drive capability for the BNC inputs and outputs. The buffer outputs are filtered with an RC network to reduce the transients caused by buffer switching.

## JTAG ACCESS

The CS61583 implements JTAG boundary scan to support board-level testing. Interface port J56 provides access to the four JTAG pins on the CS61583. The J-TMS pin of the CS61583 is pulled-down by resistor R28 to disable boundary scan unless the pin is externally pulled high using the interface port.

## TRANSFORMER SELECTION

The evaluation board is supplied from the factory with Pulse Engineering PE-65388

transformers installed at locations T1-T4. They are socketed to permit the evaluation of other transformers.

## LINE PROTECTION EVALUATION

Several optional resistor and diode locations on the transmit and receive line interface allow for the installation and evaluation of various types of protection circuitry. Each location is drilled with 60 mil vias to permit the installation of sockets. These sockets can be obtained from McKenzie at (510) 651-2700 by requesting part #PPC-SIP-1X32-620C and are identical to the socket type installed at various resistor locations on the board. They allow the line protection circuitry to be easily changed during testing. Note that the traces forming shorts between the socket locations on the line interface may need to be cut prior to protection circuitry installation.

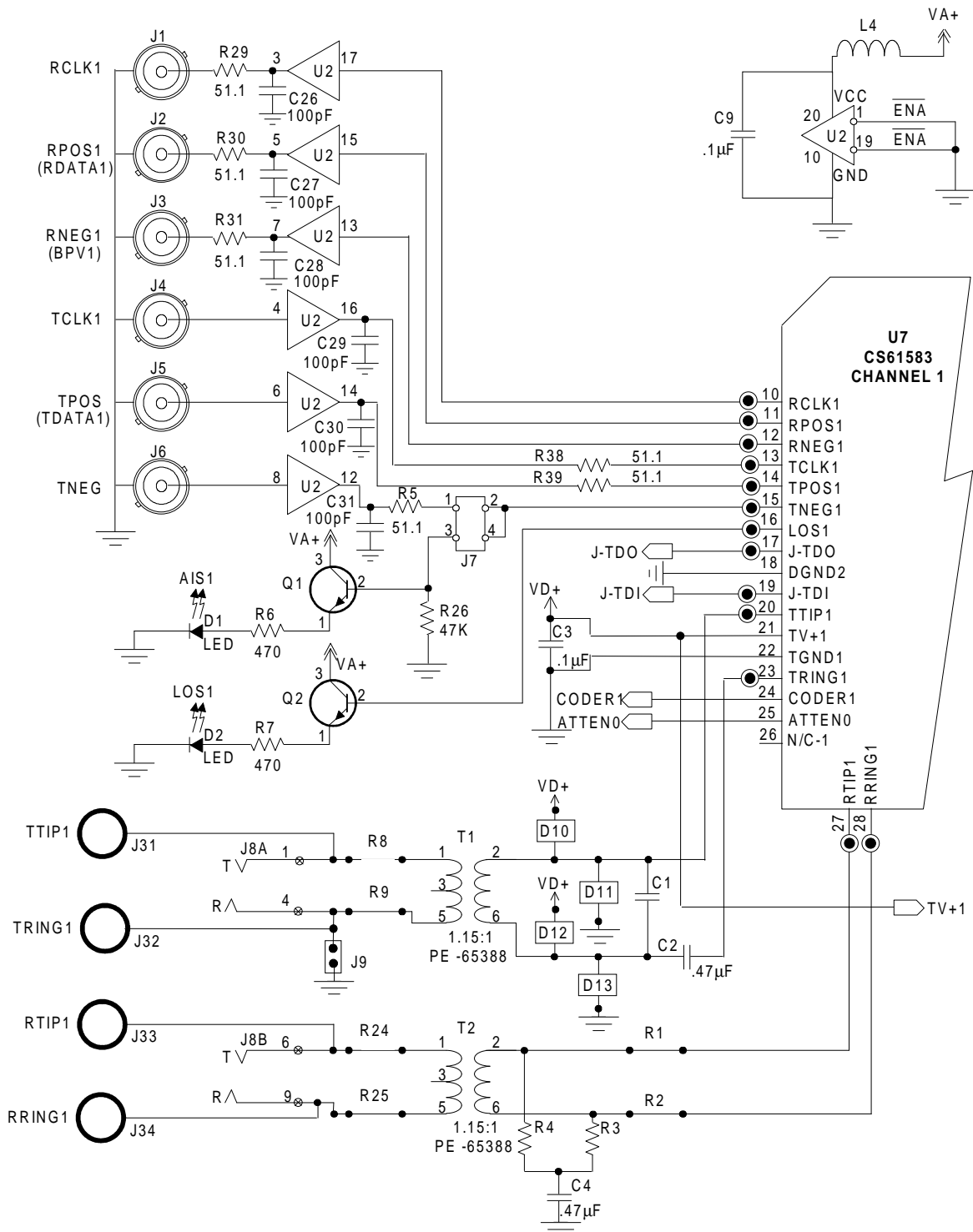
## PROTOTYPING AREA

Four prototyping areas with power supply and ground connections are provided on the evaluation board. These areas can be used to develop and test a variety of additional circuits such as framer devices, system synchronizer PLLs, or specialized interface logic.

## EVALUATION HINTS

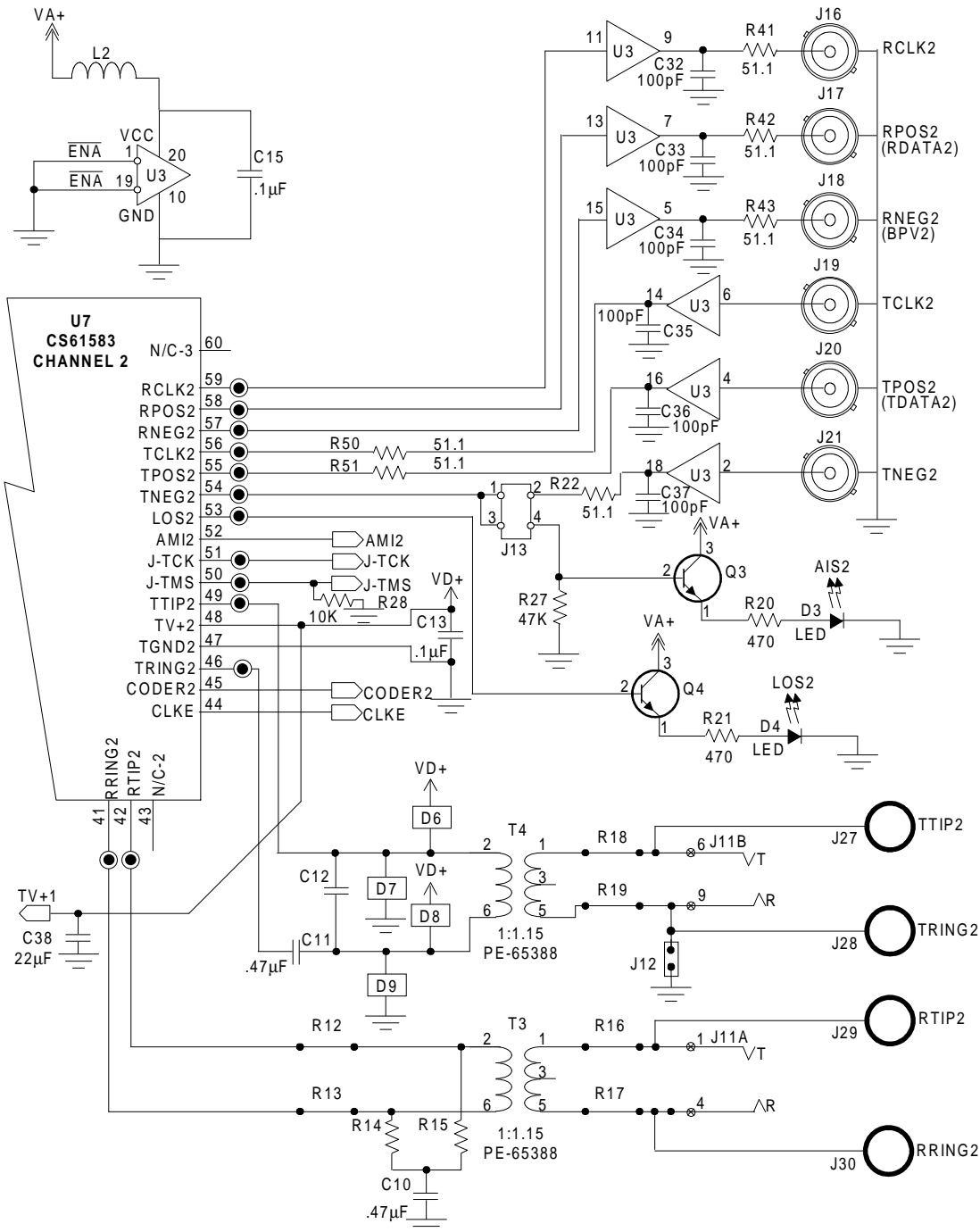
1. The orientation of pin 1 for the CS61583 is labeled "1" on the left side of the socket U7.
2. A jumper must be placed on header J10 when using the CDB61583.
3. Component locations R3-R4, R14-R15, C1, and C12 must have the correct values installed according to the application. All the necessary components are included with the evaluation board.

4. Closing a DIP switch on SW2, SW3, and SW4 towards the label sets the CS61583 control pin of the same name to logic 1.
  
5. When performing a manual loopback of the recovered signal to the transmit signal at the BNC connectors, the recovered data must be valid on the falling edge of RCLK to properly latch the data in the transmit direction. To accomplish this, the SW2 switch position labeled "CLKE" must be closed (logic 1).
  
6. Jumpers can be placed on headers J9 and J12 to provide a ground reference on TRING for 75 $\Omega$  coax E1 applications.
  
7. Properly terminate TTIP/TRING when evaluating the transmit output pulse shape. For more information concerning pulse shape evaluation, refer to the Crystal application note entitled "Measurement and Evaluation of Pulse Shapes in T1/E1 Transmission Systems."



Notes: Components R3, R4, and C1 are socketed to permit value changes to the application.  
 Component locations R1, R2, R8, R9, R24, R25, and D10-D13 provide areas for evaluating protection circuitry.

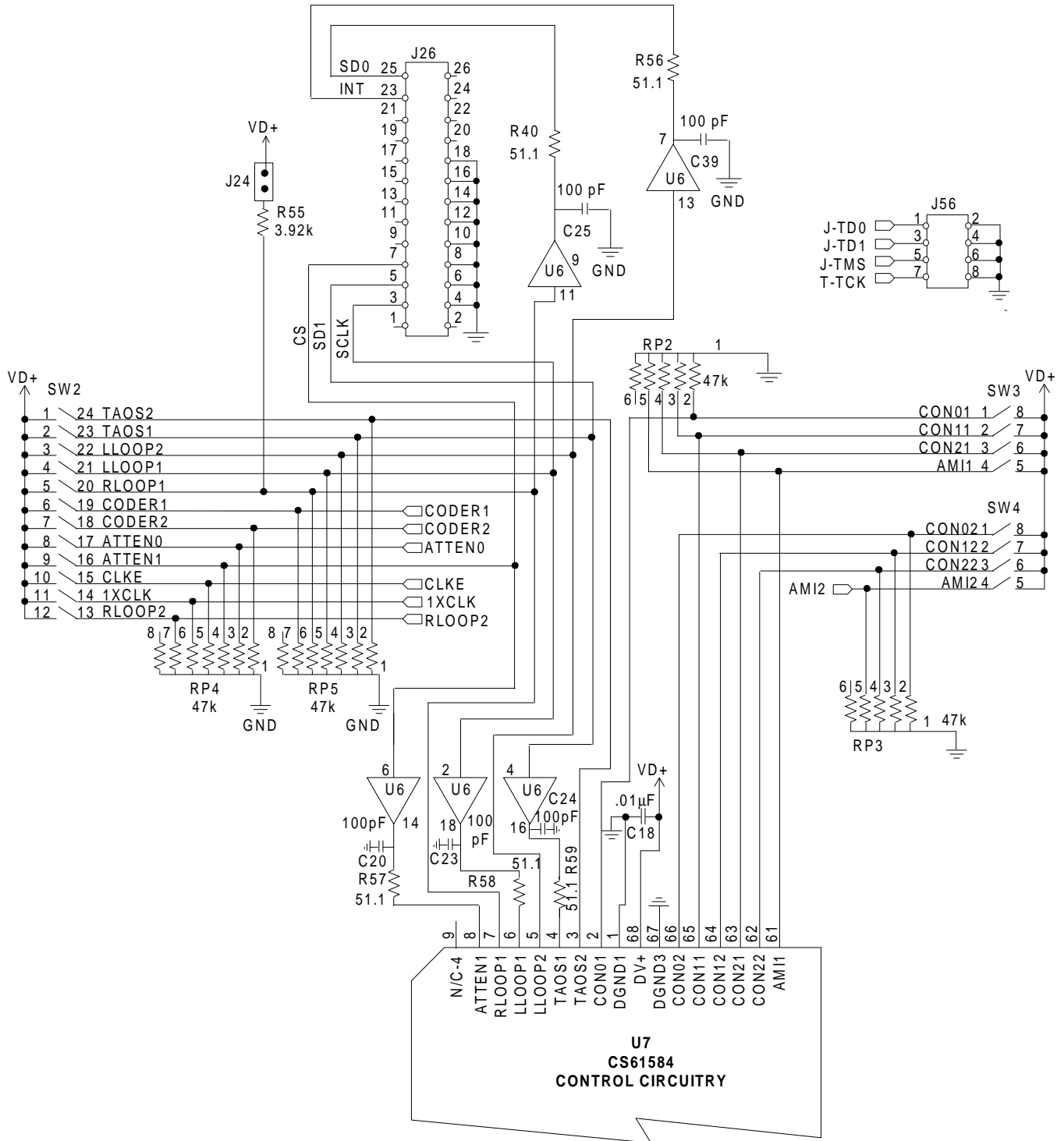
Figure 1. Channel 1 Circuitry



Notes: Components R14, R15, and C12 are socketed to permit value changes according to the application.  
 Component locations R12, R13, R16-R19, and D6-D9 provide areas for evaluating protection circuitry.

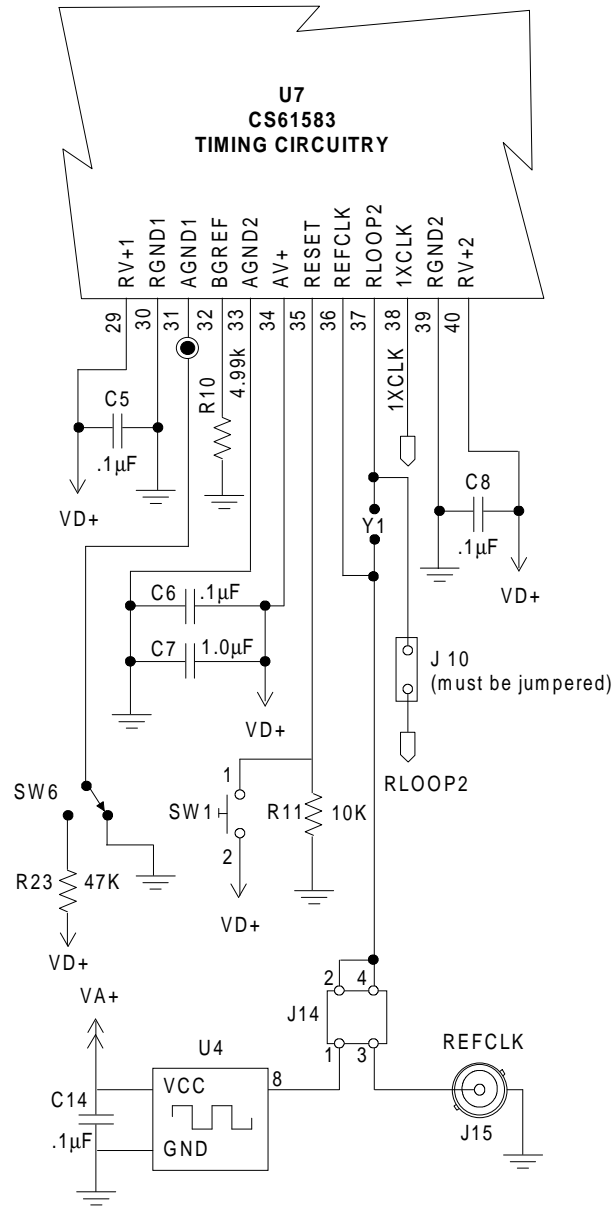
Figure 2. Channel 2 Circuitry





Note: The Host interface at J26 is not used on the CDB61583.

Figure 3. Control Circuitry



Notes: A crystal oscillator at U4 or external reference supplied at J15 must be provided.  
A quartz crystal cannot be used with the CS61583

Figure 4. Timing Circuitry

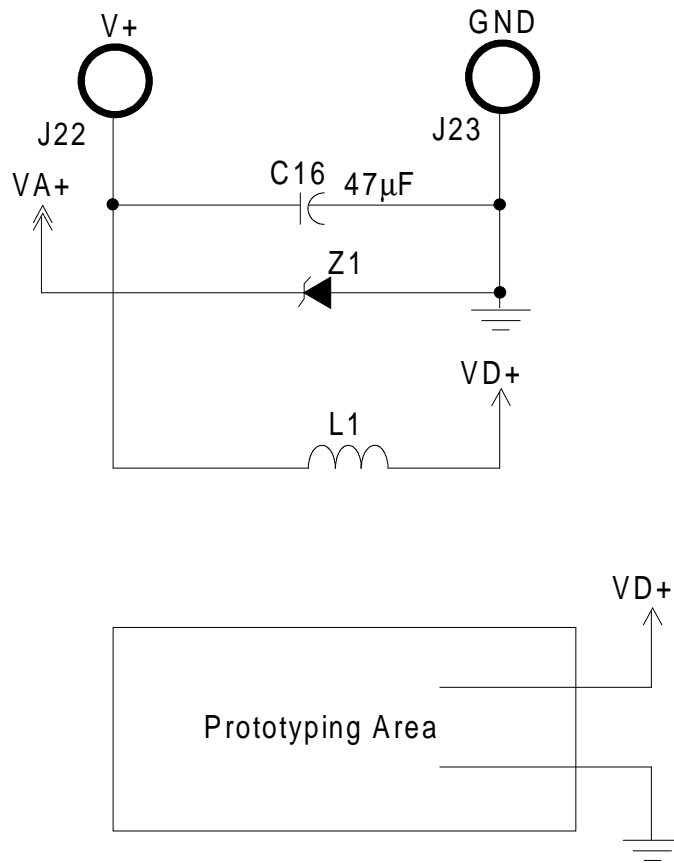


Figure 5. Common Circuitry



Smart *Analog*<sup>TM</sup> is a Trademark of Crystal Semiconductor Corporation

# Mouser Electronics

Authorized Distributor

Click to View Pricing, Inventory, Delivery & Lifecycle Information:

[Cirrus Logic:](#)

[CS495313-CQZ](#) [CS495313-CQZR](#)