

SSL Interface Controller for Analog (0-10V), PWM, and Resistor Dimming with Optocoupler Delay Elimination

1 Description

The iW350 is a PWM signal generator that works with three different types of dimming inputs, 0-10V PWM dimming, 0-10V linear dimming or simple dimming using a single resistor to ground from the DIM pin. The iW350 auto detects the dimmer type connected. A PWM dimming type is directly used, while the 0-10V linear dimming and resistor dimming signals are converted into a 0%-100% PWM duty cycle that can then be used to provide a dimming signal to a primary-side LED driver such as the iW3636, removing the need for transformers or other driver circuitry. The output of the iW350 is optimized in such a way as to remove the impact of the non-linear delay typical of optocouplers.

The iW350 offers a high level of flexibility by offering programmability for the maximum dimming voltage, minimum output duty cycle and the turn-off threshold voltage through external resistors. The output PWM frequency is also programmable from 100Hz to 5kHz through a single capacitor to ground. The input to the iW350 integrates the necessary current source to interface with both active and passive 0-10V dimmers without additional circuitry, while the output can drive an optocoupler to provide isolated dimming control from the secondary to the primary.

2 Features

- 15V to 60V operating voltage
- 3-in-1 dimmer interface
 - » 0-10V PWM dimming
 - » 0-10V linear dimming
 - » Single resistor dimming
- Dimmer type - auto detect
 - » PWM or DC input dimming signal
- 0% to 100% PWM output
 - » 1% PWM duty cycle tolerance
 - » Selectable frequency range via external capacitor
 - » Unique duty cycle drive to account for non-linear optocoupler delay
- SOIC-8 package
- External resistor configuration
 - » Programmable max dimming voltage: 8.5V, 9V, 9.5V and 10V
 - » Programmable minimum duty cycle: 1%, 3%, 5% and 10%
 - » Programmable turn-off threshold: 0.5V, 0.6V, 0.7V and 0.8V
- Programmable PWM output frequency range: 100Hz-5kHz
- Integrated current source for driving 0-10V dimmer
- Low power shutdown mode
- Integrated optocoupler driver for isolated applications

3 Applications

- 0-10V LED dimming application
- 3-in-1 LED driver interface chip (0-10V linear, 0-10V PWM and R dimming) dimming LED driver application

SSL Interface Controller for Analog (0-10V), PWM, and Resistor Dimming with Optocoupler Delay Elimination

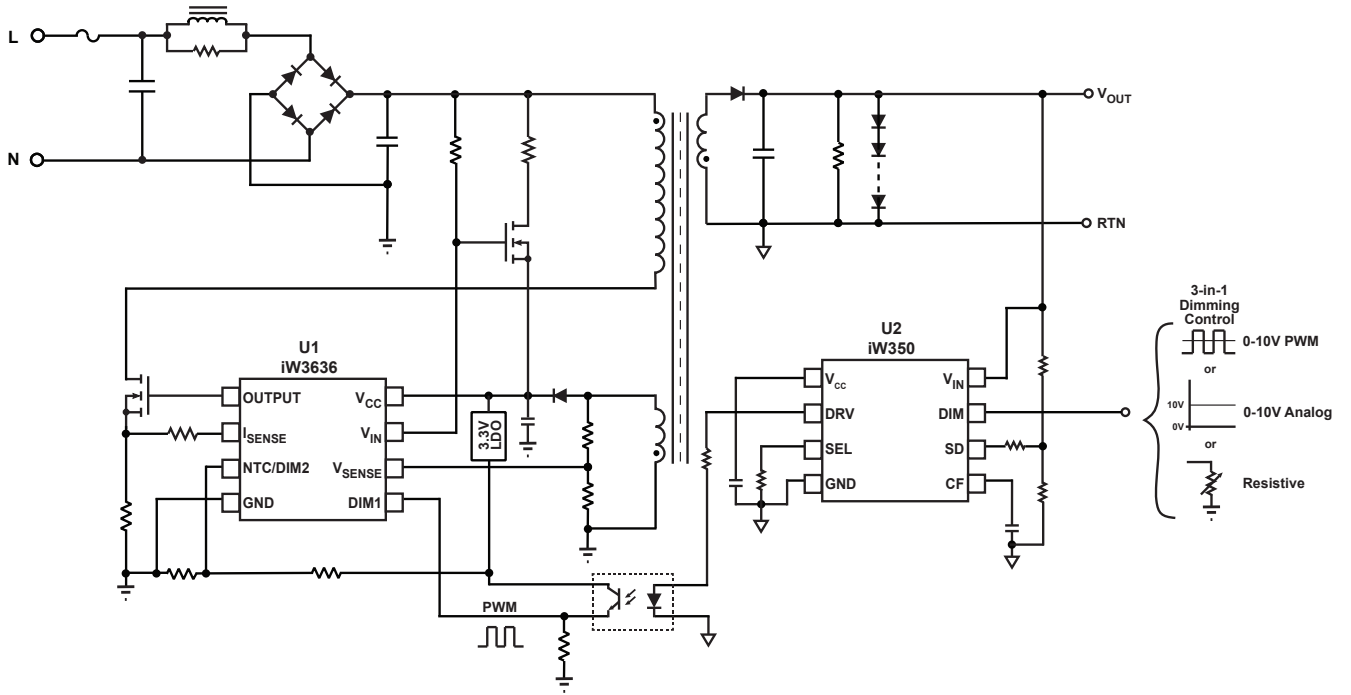

Figure 3.1 : iW350 Typical Application Circuit

SSL Interface Controller for Analog (0-10V), PWM, and Resistor Dimming with Optocoupler Delay Elimination

4 Pinout Description

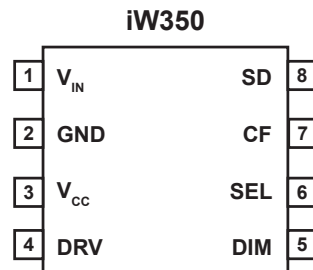

Figure 4.1 : 8-Lead SOIC Package

Pin Number	Pin Name	Type	Pin Description
1	V _{IN}	Power	Power supply up to 60V.
2	GND	Ground	Ground.
3	V _{CC}	Power	5V power supply for internal circuit, connect a 4.7uF capacitor to GND.
4	DRV	Digital Output	PWM driver.
5	DIM	Analog Input/Output	Dimming interface connection.
6	SEL	Analog Input/Output	Connect an external resistor to set max dimming voltage and turn-off threshold voltage.
7	CF	Analog Input/Output	Sets the PWM output frequency: 100Hz to 5kHz.
8	SD	Analog Input/Output	Shuts down the IC if voltage is over 0.5V, and programs the minimum duty cycle with a resistor to ground.

SSL Interface Controller for Analog (0-10V), PWM, and Resistor Dimming with Optocoupler Delay Elimination

5 Absolute Maximum Ratings

Absolute maximum ratings are the parameter values or ranges which can cause permanent damage if exceeded.

Parameter	Symbol	Value	Units
V_{IN} to GND	V_{IN}	-0.3 to 65	V
V_{CC} to GND (IC internal power supply)	V_{CC}	-0.3 to 6.5	V
DIM to GND	V_{DIM}	-0.3 to 65	V
DRV, CF, SD and SEL to GND		-0.3 to 6.5	V
ESD rating (HBM)		± 2	kV
Storage temperature range	T_{STRG}	150	$^{\circ}\text{C}$
Maximum junction temperature	T_{JMAX}	150	$^{\circ}\text{C}$

SSL Interface Controller for Analog (0-10V), PWM, and Resistor Dimming with Optocoupler Delay Elimination

6 Physical Dimensions

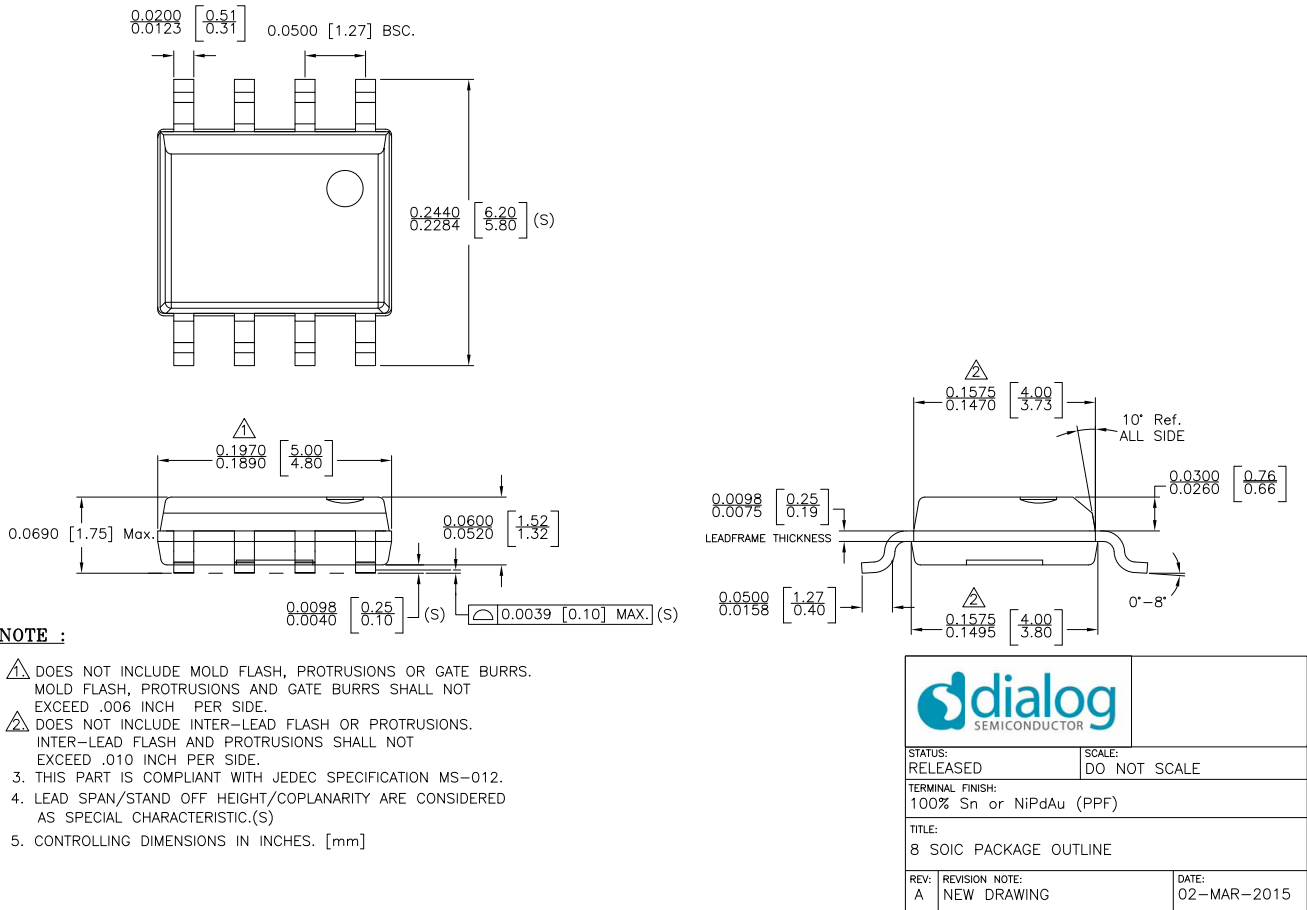

Figure 6.1 : Physical Dimensions of 8-Pin SOIC Package

7 Ordering Information

Part Number	Options	Package	Description
iW350-00 ¹ iW350-00B iW350-00AB	Standard PWM Output; Dimming Curve Figure 9.1; Turn-off Function Disabled	SOIC-8	Tape & Reel ²
iW350-02 ¹ iW350-02B	Standard PWM Output; Dimming Curve Figure 9.2; Turn-off Function Disabled	SOIC-8	Tape & Reel ²
iW350-30 ¹ iW350-30B iW350-30AB	Standard PWM Output; Dimming Curve Figure 9.3; Turn-off Function Enabled	SOIC-8	Tape & Reel ²
iW350-32 ¹ iW350-32B	Standard PWM Output; Dimming Curve Figure 9.4; Turn-off Function Enabled	SOIC-8	Tape & Reel ²

Note 1. Not recommended for new designs, please use the -xxB version.

Note 2. Tape and reel packing quantity is 2,500/reel. Minimum packing quantity is 2,500.

SSL Interface Controller for Analog (0-10V), PWM, and Resistor Dimming with Optocoupler Delay Elimination

Disclaimer

Unless otherwise agreed in writing, the Dialog Semiconductor products (and any associated software) referred to in this document are not designed, authorized or warranted to be suitable for use in life support, life-critical or safety-critical systems or equipment, nor in applications where failure or malfunction of a Dialog Semiconductor product (or associated software) can reasonably be expected to result in personal injury, death or severe property or environmental damage. Dialog Semiconductor and its suppliers accept no liability for inclusion and/or use of Dialog Semiconductor products (and any associated software) in such equipment or applications and therefore such inclusion and/or use is at the customer's own risk.

Information in this document is believed to be accurate and reliable. However, Dialog Semiconductor does not give any representations or warranties, express or implied, as to the accuracy or completeness of such information. Dialog Semiconductor furthermore takes no responsibility whatsoever for the content in this document if provided by any information source outside of Dialog Semiconductor.

Dialog Semiconductor reserves the right to change without notice the information published in this document, including, without limitation, the specification and the design of the related semiconductor products, software and applications. Notwithstanding the foregoing, for any automotive grade version of the device, Dialog Semiconductor reserves the right to change the information published in this document, including, without limitation, the specification and the design of the related semiconductor products, software and applications, in accordance with its standard automotive change notification process.

Applications, software, and semiconductor products described in this document are for illustrative purposes only. Dialog Semiconductor makes no representation or warranty that such applications, software and semiconductor products will be suitable for the specified use without further testing or modification. Unless otherwise agreed in writing, such testing or modification is the sole responsibility of the customer and Dialog Semiconductor excludes all liability in this respect.

Nothing in this document may be construed as a license for customer to use the Dialog Semiconductor products, software and applications referred to in this document. Such license must be separately sought by customer with Dialog Semiconductor.

All use of Dialog Semiconductor products, software and applications referred to in this document is subject to Dialog Semiconductor's [Standard Terms and Conditions of Sale](#), available on the company website (www.dialog-semiconductor.com) unless otherwise stated.

Dialog, Dialog Semiconductor and the Dialog logo are trademarks of Dialog Semiconductor Plc or its subsidiaries. All other product or service names and marks are the property of their respective owners.

© 2020 Dialog Semiconductor. All rights reserved.

RoHS Compliance

Dialog Semiconductor's suppliers certify that its products are in compliance with the requirements of Directive 2011/65/EU of the European Parliament on the restriction of the use of certain hazardous substances in electrical and electronic equipment. RoHS certificates from our suppliers are available on request.

Contacting Dialog Semiconductor

United Kingdom (Headquarters)
Dialog Semiconductor (UK) LTD
Phone: +44 1793 757700

Germany
Dialog Semiconductor GmbH
Phone: +49 7021 805-0

The Netherlands
Dialog Semiconductor B.V.
Phone: +31 73 640 8822

Email
info_pcbg@diasemi.com

North America
Dialog Semiconductor Inc.
Phone: +1 408 845 8500

Japan
Dialog Semiconductor K. K.
Phone: +81 3 5769 5100

Taiwan
Dialog Semiconductor Taiwan
Phone: +886 281 786 222

Web site:
www.dialog-semiconductor.com

Hong Kong
Dialog Semiconductor Hong Kong
Phone: +852 2607 4271

Korea
Dialog Semiconductor Korea
Phone: +82 2 3469 8200

China (Shenzhen)
Dialog Semiconductor China
Phone: +86 755 2981 3669

China (Shanghai)
Dialog Semiconductor China
Phone: +86 21 5424 9058

Mouser Electronics

Authorized Distributor

Click to View Pricing, Inventory, Delivery & Lifecycle Information:

[Dialog Semiconductor:](#)

[IW350-00](#) [IW350-02](#) [IW350-30](#) [IW350-32](#) [IW350-00B](#) [IW350-02B](#) [IW350-30B](#) [IW350-32B](#)