

Remove transport lock before use.

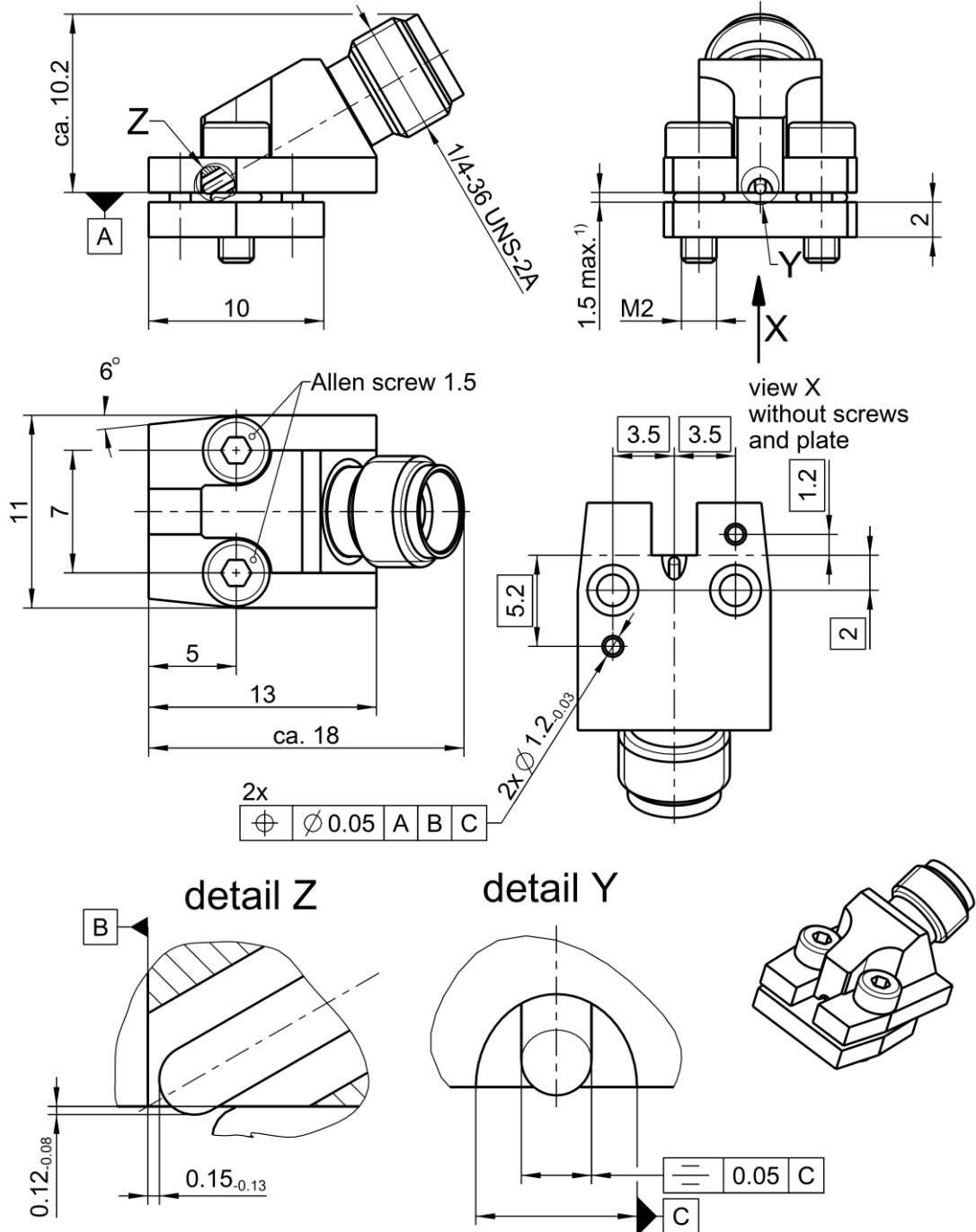

All dimensions are in mm; tolerances according to ISO 2768 m-H

Interface

According to IEC 61169-35
Mechanically compatible with RPC-3.50 and SMA

Documents

PCB layout MB 425
Handling Instruction HI_016

Dieses Dokument ist urheberrechtlich geschützt • This document is protected by copyright • Rosenberger Hochfrequenztechnik GmbH & Co. KG

RF_35/05.10/6.0

Technical Data Sheet

Rosenberger

RPC-2.92

SMD Connector jack

02K80F-40ML5

Material and plating

Connector parts

Center contact
Outer contact PCB side
Outer contact RPC-2.92 side
Dielectric

Material

CuBe
CuBe or equiv.
CuBe or equiv.
PEEK

Plating

AuroDur®, gold plated
AuroDur®, gold plated
AuroDur®, gold plated

Electrical data

Impedance 50 Ω
Frequency DC to 40 GHz
Return loss ≥ 21 dB, DC to 26.5 GHz
≥ 19 dB, 26.5 GHz to 40 GHz
Insertion loss ≤ 0.04 x √f(GHz) dB
Insulation resistance ≥ 5 GΩ
Test voltage 750 V rms
Working voltage 250 V rms

- Return loss in application depends decisive on PCB layout -

Mechanical data

Mating cycles PCB side ≥ 300
Mating cycles RPC-2.92 side ≥ 500
Center contact captivation ≥ 20 N
Coupling test torque RPC-2.92 1.70 Nm
Recommended torque RPC-2.92 0.80 Nm to 1.10 Nm
Recommended torque Allen screw 1.5 0.20 Nm to 0.30 Nm
PCB thickness max.¹ 1.5 mm typical; dimension expandable with longer screws

Environmental data

Temperature range -40°C to +85°C
Thermal shock MIL-STD-202, Method 107, Condition B
Corrosion MIL-STD-202, Method 101, Condition B
Vibration MIL-STD-202, Method 204, Condition D
Shock MIL-STD-202, Method 213, Condition I
Moisture resistance MIL-STD-202, Method 106
Max. soldering temperature N/A (connector is only screwed on, not soldered)
RoHS compliant

Tooling

Allen wrench 1.5 mm

Packing

Standard 1 pce in box
50 pcs in blister
Weight 6.7 g/pce

While the information has been carefully compiled to the best of our knowledge, nothing is intended as representation or warranty on our part and no statement herein shall be construed as recommendation to infringe existing patents. In the effort to improve our products, we reserve the right to make changes judged to be necessary.

Draft	Date	Approved	Date	Rev.	Engineering change number	Name	Date
M. Scherbauer	26.01.18	Florian Reiner	06.12.18	b00	18-2217	S. Schmid	06.12.18
Rosenberger Hochfrequenztechnik GmbH & Co. KG P.O.Box 1260 D-84526 Tittmoning Germany www.rosenberger.de					Tel. : +49 8684 18-0 Fax : +49 8684 18-499 Email : info@rosenberger.de		Page 2 / 2

Mouser Electronics

Authorized Distributor

Click to View Pricing, Inventory, Delivery & Lifecycle Information:

[Rosenberger:](#)

[02K80F-40ML5](#)