

| AMP "M" SERIES<br>TYPE 2 CONTACTS | COLOR CODE | 14 | 16 | 18 | 20 | 22 | 24 | WIRE<br>SIZE |
|-----------------------------------|------------|----|----|----|----|----|----|--------------|
| STD                               | RED        | 7  |    |    |    |    |    | SELECTOR NO. |
|                                   |            |    | 6  | 5  | 4  |    |    |              |
|                                   |            |    |    |    | 4  | 3  | 2  |              |
| LONG                              | BLUE       |    |    |    |    |    |    |              |
|                                   |            | 7  |    |    |    |    |    |              |
|                                   |            |    | 6  | 5  | 4  |    |    |              |
| INSULATION STD                    | GREEN      |    |    |    |    |    |    |              |
|                                   |            |    |    |    |    |    |    |              |
|                                   |            |    |    |    | 4  | 3  | 2  |              |

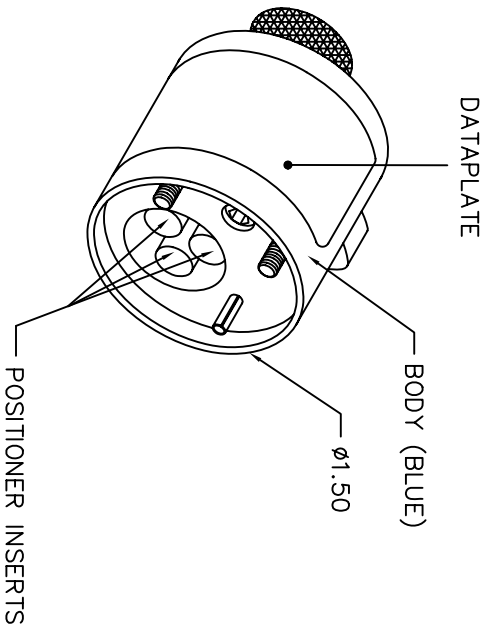

| POSITIONER<br>COLOR | HOLE<br>DIMENSIONS        | ADDITIONAL<br>FEATURES              |
|---------------------|---------------------------|-------------------------------------|
| RED                 | $\phi .078$<br>$\pm .654$ | $\sqsubset \phi .156$<br>$\pm .514$ |
| BLUE                | $\phi .078$<br>$\pm .812$ | $\sqsubset \phi .156$<br>$\pm .514$ |
| GREEN               | $\phi .078$<br>$\pm .764$ | $\sqsubset \phi .156$<br>$\pm .624$ |

\* HOLE AND COUNTERBORE DEPTHS ARE MEASURED FROM TOP OF POSITIONER INSERTS.

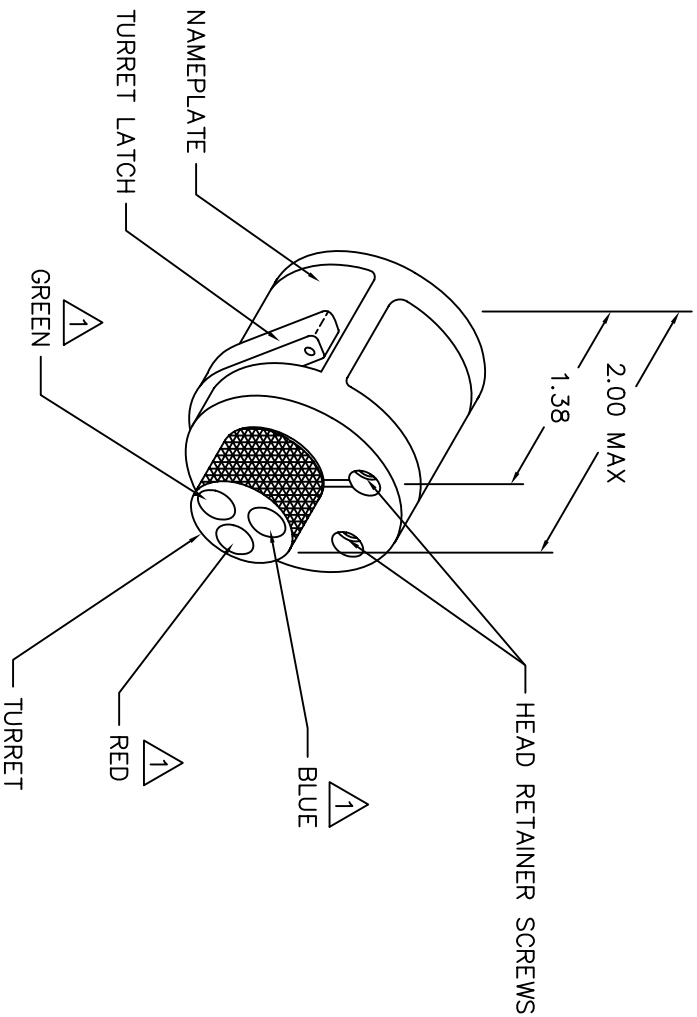

1 RANDOM ORDER OF ROTATION IS ACCEPTABLE.

| REVISIONS |               |             |             |
|-----------|---------------|-------------|-------------|
| REV.      | E.C.O. NUMBER | DESCRIPTION | BY DATE     |
| 2         |               | REDRAWN     | AAM 1-28-01 |

**UNCONTROLLED DOCUMENT  
WILL NOT BE UPDATED**

**RESTRICTED & CONFIDENTIAL**  
 CONFIDENTIAL PROPERTY OF DANIELS MANUFACTURING CORP. NOT TO BE DISCLOSED TO OTHERS, REPRODUCED OR USED FOR ANY OTHER PURPOSE, EXCEPT AS AUTHORIZED IN WRITING BY DANIELS MANUFACTURING. MUST BE RETURNED TO DANIELS MANUFACTURING FOR REUSE OR DESTRUCTION OF OTHER PURPOSE FOR WHICH LENT.

| ITEM  | PART NO. | QTY.     | DESCRIPTION/REMARKS |
|-------|----------|----------|---------------------|
| DRWL  | BY DATE  | 11-8-85  |                     |
| CHK'D | DATE     | 11-8-85  |                     |
| APP'D | DATE     | 11-15-85 |                     |
| APP'D | DATE     |          |                     |

NOTE: THIS DRAWING IS AN OUTLINE DRAWING OF THE RESPECTIVE INDICATED PART. ACTUAL DIMS PART NUMBER IS DRAWING NUMBER WITHOUT THE "-ENV" SUFFIX.

WHERE USED: AFB

| SIZE | SCALE | CAD P/N   | SHEET  |
|------|-------|-----------|--------|
| B    | NTS   | TH402-ENV | 1 OF 1 |

DO NOT SCALE DRAWING

**Daniel's Manufacturing Corp.**  
 DANIELS MANUFACTURING CORP.  
 ORLANDO, FLORIDA  
 CASE 11851

TITLE  
 ENVELOPE DRAWING  
 TURRET HEAD

REV 2

# Mouser Electronics

Authorized Distributor

Click to View Pricing, Inventory, Delivery & Lifecycle Information:

[Daniels Manufacturing:](#)

[TH402](#)