

REVISIONS						
REV	ECO NO.	DESCRIPTION	BY	DATE	APP'D BY	DATE
1		ORIGINAL RELEASE	AAM	12/11/1997	RRR	12/11/1997
2	23573	UPDATED & REDRAWN	TonyD	6/3/2015		

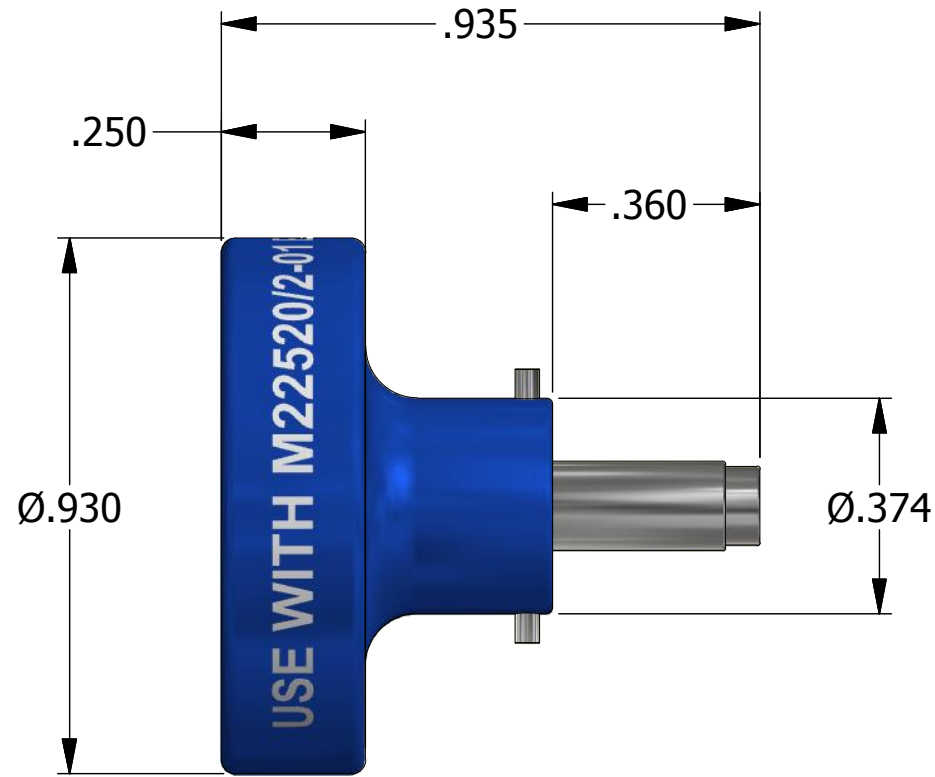

**UNCONTROLLED DOCUMENT  
WILL NOT BE UPDATED**  
DIMENSIONS IN INCHES - UNLESS OTHERWISE SPECIFIED

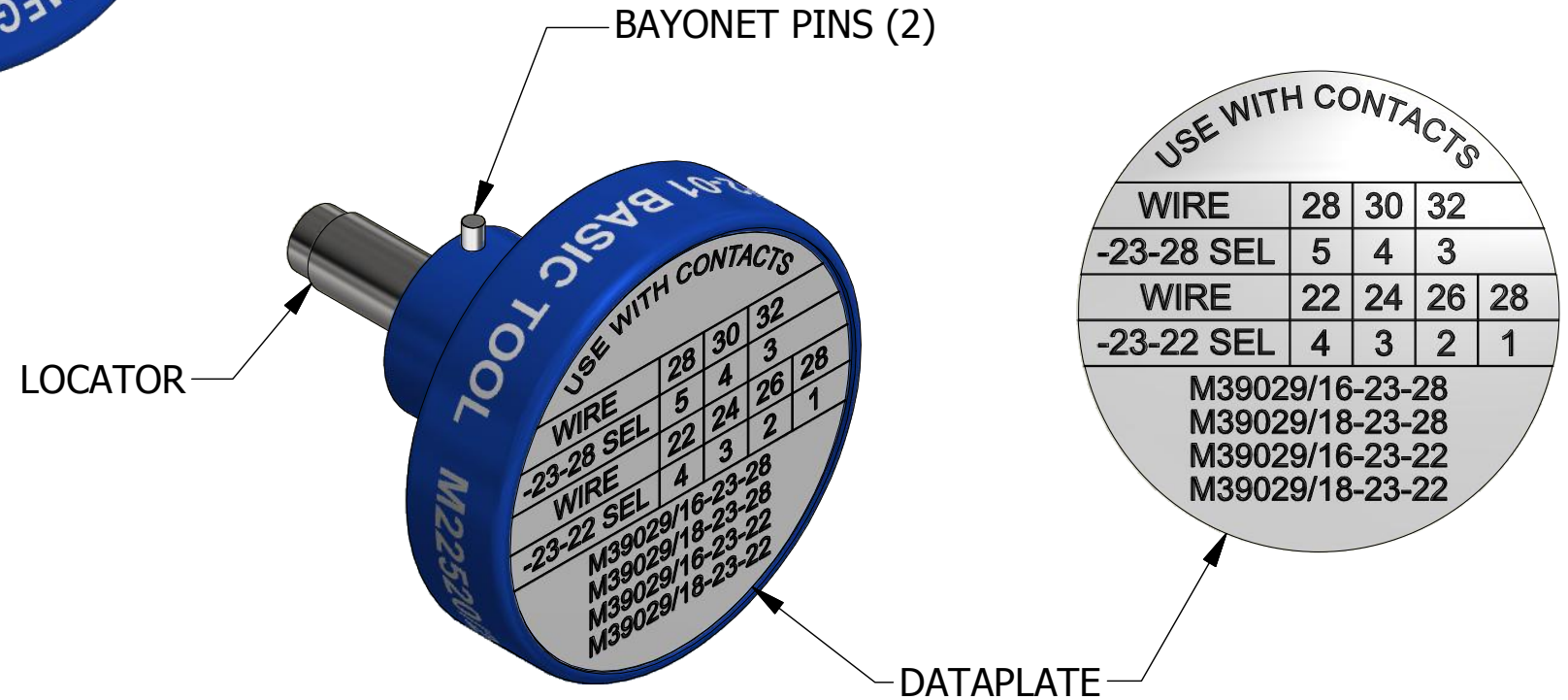

LOCATOR	
HOLE DIMENSIONS	ADDITIONAL FEATURES
Ø.031 ▽.510	└┘Ø.057 ▽.480

MATERIAL	ITEM	PART NO.	QTY.	DESCRIPTION / REMARKS
N/A	DRN. A. MOO-YOUNG CHK'D.	DATE 12/11/1997 DATE		<b>DMC</b> DANIELS MANUFACTURING CORP. ORLANDO, FLORIDA CAGE 11851
RESTRICTED & CONFIDENTIAL CONFIDENTIAL PROPERTY OF DANIELS MANUFACTURING CORP. NOT TO BE DISCLOSED TO OTHERS. REPRODUCTION OR USED FOR ANY OTHER PURPOSE EXCEPT AS AUTHORIZED IN WRITING BY DANIELS MANUFACTURING. MUST BE RETURNED TO DANIELS MANUFACTURING CORP. ON COMPLETION OF ORDER OR PURPOSES FOR WHICH LENT.	HEAT TREAT	N/A		NOTE: THIS DRAWING IS AN OUTLINE DRAWING OF THE RESPECTIVE DMC PART NUMBER INDICATED. ACTUAL DMC PART NUMBER IS CAD PART NUMBER WITHOUT THE "-ENV" SUFFIX
CREATED FROM AN INVENTOR MODEL. CHANGES MUST BE REFLECTED IN THE 3D PART	FINISH	N/A		TITLE POSITIONER (M22520/2-13) ENVELOPE DRAWING WHERE USED: AFM8
DO NOT SCALE DRAWING				SIZE B
				SCALE 3 : 1
				CAD P/N K338-ENV
				SHEET 1 OF 1
				DWG. NO. K338
				REV. 2

# Mouser Electronics

Authorized Distributor

Click to View Pricing, Inventory, Delivery & Lifecycle Information:

[Daniels Manufacturing:](#)

[M22520/2-13](#) [K338](#)