



## 14A Active EMI Filter SiP for 24V<sub>DC</sub> Bus

### Product Description

The QPI-5 active EMI filter attenuates conducted common-mode (CM) and differential-mode (DM) noise over the CISPR22 frequency range of 150kHz to 30MHz. The product is designed for use on 24V<sub>DC</sub> bus (10 – 40V<sub>DC</sub>) systems, with 100V<sub>DC</sub> surge capability. The QPI-5's 14A rating supports multiple DC-DC converter loads up to an ambient temperature of 65°C without de-rating. Designed for the telecom and ITE bus range, the QPI-5 supports the PICMG® 3.0 specification for filtering system boards to the EN55022 Class B limits.

In comparison to passive solutions, the use of active filtering reduces the volume of the common-mode choke, providing a low-profile, surface-mount device. Smaller size saves valuable board real estate and the reduced height enhances airflow in blade applications.

The QPI-5 is available as a lidded or an open-frame SiP (System-in-Package) with LGA mounting. Evaluation boards are available to allow for quick in-circuit testing of the QPI-5LZ within an existing system design.



### Features & Benefits

- 60dB CM attenuation at 250kHz (50Ω)
- 75dB DM attenuation at 250kHz (50Ω)
- 40V<sub>DC</sub> (max input)
- 100V<sub>DC</sub> surge 100ms
- 707V<sub>DC</sub> hipot hold off to shield plane
- 14A rating
- Low-profile LGA package
- ~1in<sup>2</sup> area
- -40 to +125°C ambient temperature (see Figure 9)
- Efficiency >99%
- Connect in series for higher attenuation
- TÜV certified

### Applications

- Industrial Bus Supplies
- Telecom Base Stations
- IBA & Distributed Power
- COTS Systems

### Package Information

- 25.3 x 25.3 x 5.2mm lidded SiP (System-in-Package)
- 24.9 x 24.9 x 4.4mm open-frame SiP

### Typical Application

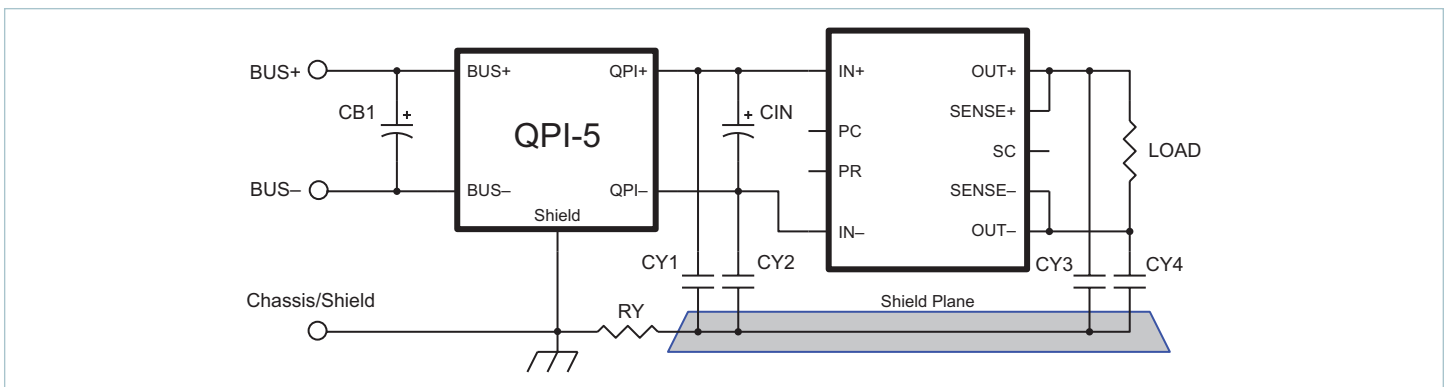

QPI-5 schematic with a Vicor Brick® converter<sup>[a]</sup>

<sup>[a]</sup> CB1 capacitor, referenced in all schematics, is a 47μF electrolytic; United Chemi-Con EMVE101ARA470MKE05 or equivalent.  
CY1 to CY4, referenced in all schematics, are 4.7nF high-voltage safety capacitors; Vishay VY1472M63Y5UQ63V0 or equivalent.  
CIN is the manufacturer's recommended value for input capacitor.

Contents

Order Information 3

Absolute Maximum Ratings 3

Electrical Characteristics 3

Package Pinout 4

Applications Information 5

    EMI Sources 5

    Passive EMI Filtering 5

    Active EMI Filtering 5

    EMI Management 6

Attenuation Test Set Ups 7

Attenuation Plots 8

Current De-Rating 8

QPI Application Circuits 9

QPI Insertion Loss Measurements and Test Circuits 11

Package Outline Drawings 12

Pad and Stencil Definitions 13

PCB Layout Recommendations 14

    PCB Layout 14

    Post-Solder Cleaning 14

    QPI-5 Mechanical Data 14

Product Warranty 15

## Order Information

Product	Description
QPI-5LZ <sup>[b]</sup>	QPI-5 LGA package, RoHS compliant
QPI-5LZ-01	QPI-5 LGA package, RoHS compliant, open-frame package
Evaluation Board	Description
QPI-5-EVAL1	A QPI-5LZ mounted on a small evaluation board with screw terminal blocks to allow for easy connection into an existing system.
QPI-5-CB1	A QPI-5LZ mounted on a carrier board designed for use with DOSA compliant footprint DC-DC converters. Screw terminal blocks to allow for easy connection into an existing system.

<sup>[b]</sup> QPI-5LZ is a non-hermetically sealed package. Please read the "Post-Solder Cleaning" section on page 14.

## Absolute Maximum Ratings

Exceeding these parameters may result in permanent damage to the product.

Name	Rating
Input Voltage, BUS+ to BUS-, Continuous	-40 to 40V <sub>DC</sub>
Input Voltage, BUS+ to BUS-, 100ms Transient	-100 to 100V <sub>DC</sub>
BUS+/- BUS- to Shield Pads, Hi-pot	-707 to 707V <sub>DC</sub>
Input to Output Current, Continuous @ 25°C T <sub>A</sub>	14A <sub>DC</sub>
Input-to-Output Current, 10 seconds @ 25°C T <sub>A</sub>	20A <sub>DC</sub>
Power Dissipation, @ 65°C T <sub>A</sub> , 14A <sup>[c]</sup>	2.3W
Operating Temperature - T <sub>A</sub>	-40 to 125°C
Thermal Resistance <sup>[c]</sup> - R <sub>θJ-Ar</sub> , using PCB layout in Figure 20	20°C/W
Thermal Resistance <sup>[c]</sup> - R <sub>θJ-PCB</sub>	8°C/W
Storage Temperature, JEDEC Standard J-STD-033B	-55 to 125°C
Reflow Temperature, 20s Exposure	245°C
ESD, Human Body Model (HBM)	-2000 to 2000V

## Electrical Characteristics

Parameter limits apply over the operating temperature range unless otherwise noted.

Parameter	Conditions	Min	Typ	Max	Unit
BUS+ to BUS- Input Range	Measured at 14A, 65°C ambient temperature <sup>[c]</sup>	10		40	V <sub>DC</sub>
BUS+ to QPI+ Voltage Drop	Measured at 14A, 65°C ambient temperature <sup>[c]</sup>			135	mV <sub>DC</sub>
BUS- to QPI- Voltage Drop	Measured at 14A, 65°C ambient temperature <sup>[c]</sup>			29	mV <sub>DC</sub>
Common-Mode Attenuation	V <sub>BUS</sub> = 28V, Frequency = 250kHz, line impedance = 50Ω		60		dB
Differential-Mode Attenuation	V <sub>BUS</sub> = 28V, Frequency = 250kHz, line impedance = 50Ω		75		dB
Input Bias Current at 40V	Input current from BUS+ to BUS-		8		mA

<sup>[c]</sup> See Figure 8 for the current de-rating curve.

Package Pinout

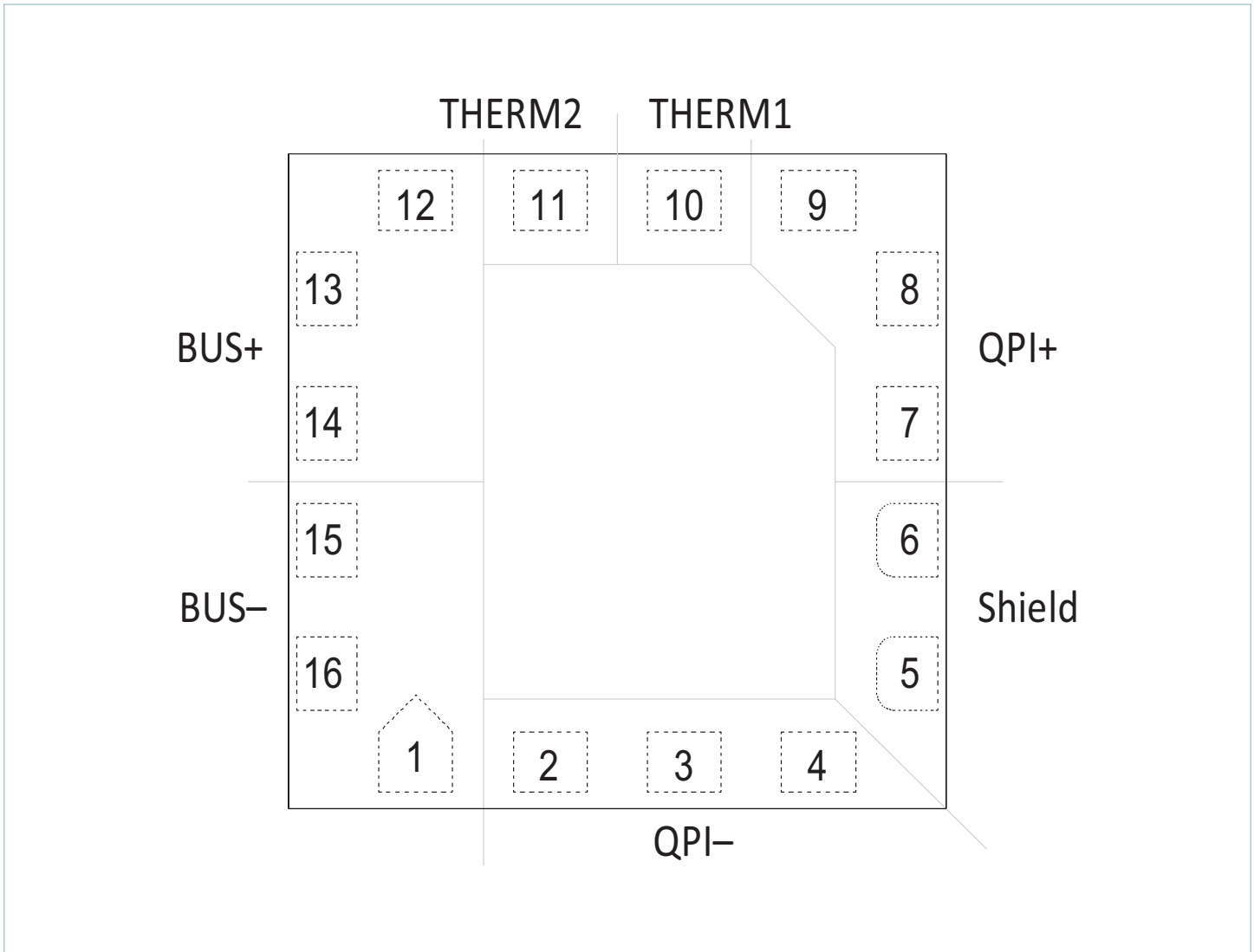

Pad Number	Name	Description
12, 13, 14	BUS+	Positive bus potential
1, 15, 16	BUS-	Negative bus potential
7, 8, 9	QPI+	Positive input to the converter
2, 3, 4	QPI-	Negative input to the converter
5, 6	Shield	Shield connects to the system chassis or to a safety ground
10	THERM1	These pads are electrically connected to the internal circuitry of the QPI-5. Either connecting THERM1 to QPI+ and THERM2 to BUS+, or to copper region(s) not connected to Shield, is recommended to help with thermal management.
11	THERM2	

## Applications Information

### EMI Sources

Many of the components in today's power conversion modules are sources of high-frequency EMI noise generation. Diodes, high-frequency switching devices, transformers and inductors, and circuit layouts passing high  $dV/dt$  or  $di/dt$  signals are all potential sources of EMI.

EMI is propagated either by radiated or conductive means. Radiated EMI can be sourced from these components as well as by circuit loops that act like antennas and broadcast the noise signals to neighboring circuit paths. This also means that these loops can act as receivers of a broadcasted signal. This radiated EMI noise can be reduced by proper circuit layout and by shielding potential sources of EMI transmission.

There are two basic forms of conducted EMI that typically need to be filtered; namely common-mode (CM) and differential-mode (DM) EMI. Differential-mode resides in the normal power loop of a power source and its load; where the signal travels from the source to the load and then returns to the source. Common-mode is a signal that travels through both leads of the source and is returned to earth via parasitic pathways, either capacitively or inductively coupled.

Figure 6 and Figure 7 are the resulting EMI plots, after filtering by the QPI-5, of the total noise, both common- and differential-mode, of a Vicor Brick converter. These converters are mounted on a QPI-5 evaluation board and tested under various loads. The red and blue traces represent the positive and negative branches of total noise, as measured using an industry-standard LISN set up, as is shown in Figures 4 and 5.

Differential-mode EMI is typically larger in magnitude than common-mode, since common-mode is produced by the physical imbalances in the differential loop path. Reducing differential EMI will cause a reduction in common-mode EMI.

### Passive EMI Filtering

The basic premise of filtering EMI is to insert a high impedance at the EMI's base frequency, in both the differential- and common-mode paths as it returns to the power source.

Passive filters use common-mode chokes and "Y" capacitors to filter out common-mode EMI. These chokes are designed to present a high impedance at the EMI frequency in series with the return path, and a low impedance path to the earth signal via the "Y" caps. This network will force the EMI signals to re-circulate within a confined area and not to propagate to the outside world. Often two common-mode networks are required to filter EMI within the frequency span required to pass the EN55022 class B limits.

The other component of the passive filter is the differential LC network. Again, the inductor is chosen such that it will present a high impedance in the differential EMI loop at the EMI's base frequency. The differential capacitor will then shunt the EMI back to its source. The QPI-5 was specifically designed to work with conventional switching frequency converters like Vicor Brick<sup>®</sup> products; Micro, Mini and Maxi modules; as well as converters from various vendors.

### Active EMI Filtering

The Vicor QPI-5 active EMI filter uses the same basic principles for filtering as the passive approach, but its active common-mode filter can perform as well as a passive filter, when filtering lower frequencies, in much less board area.

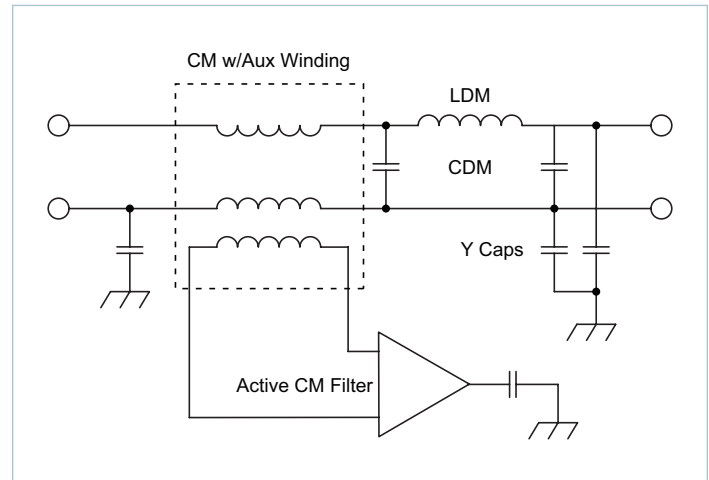

Figure 1 — Simplified active EMI filter circuit.

Typically, the lower the frequency the greater the needed inductance would be to properly filter the EMI signal. This means either a larger core or a greater number of turns on a smaller core. A larger core requires more board space, where a smaller core with more turns has a greater amount of unwanted parasitics that can affect the filter's ability to attenuate EMI signals.

Figure 1 is a simplified schematic of the QPI-5's active and passive circuitry used for EMI filtering. The QPI-5's active filter uses a small high-frequency common-mode transformer to filter the higher frequencies and adds a sensing element to it so that the lower-frequency common-mode signal can be sensed and a correction signal can be generated and inserted into the shield connection. By this means, the QPI-5 is capable of providing EMI filtering of converters in far less space than standard passive filters and can provide filtering over the entire EN55022 class B range.

**EMI Management**

The more effectively EMI is managed at the source, namely the power converter, the less EMI attenuation the filter will have to do. The addition of “Y” capacitors to the input and output power nodes of the converter will help to limit the amount of EMI that will propagate to the input source.

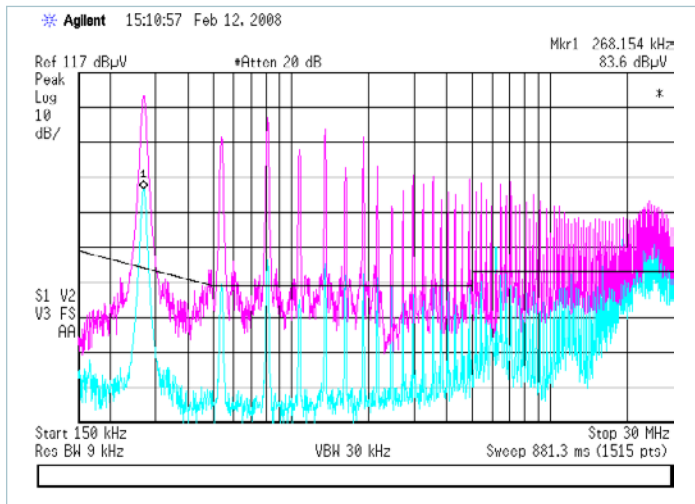

**Figure 2** — An unfiltered converter’s response to “open-frame” (light blue) and “baseplate” (purple) EMI configurations

There are two basic topologies for the connection of the re-circulating “Y” capacitors, referred to as “open-frame” and “baseplate”. Figure 2 illustrates how a converter can favor one topology versus another. The EMI generated by the “baseplate” configuration is much greater than that generated by the “open-frame”. Selecting the right topology will greatly reduce the amount of EMI signal that needs to be filtered.

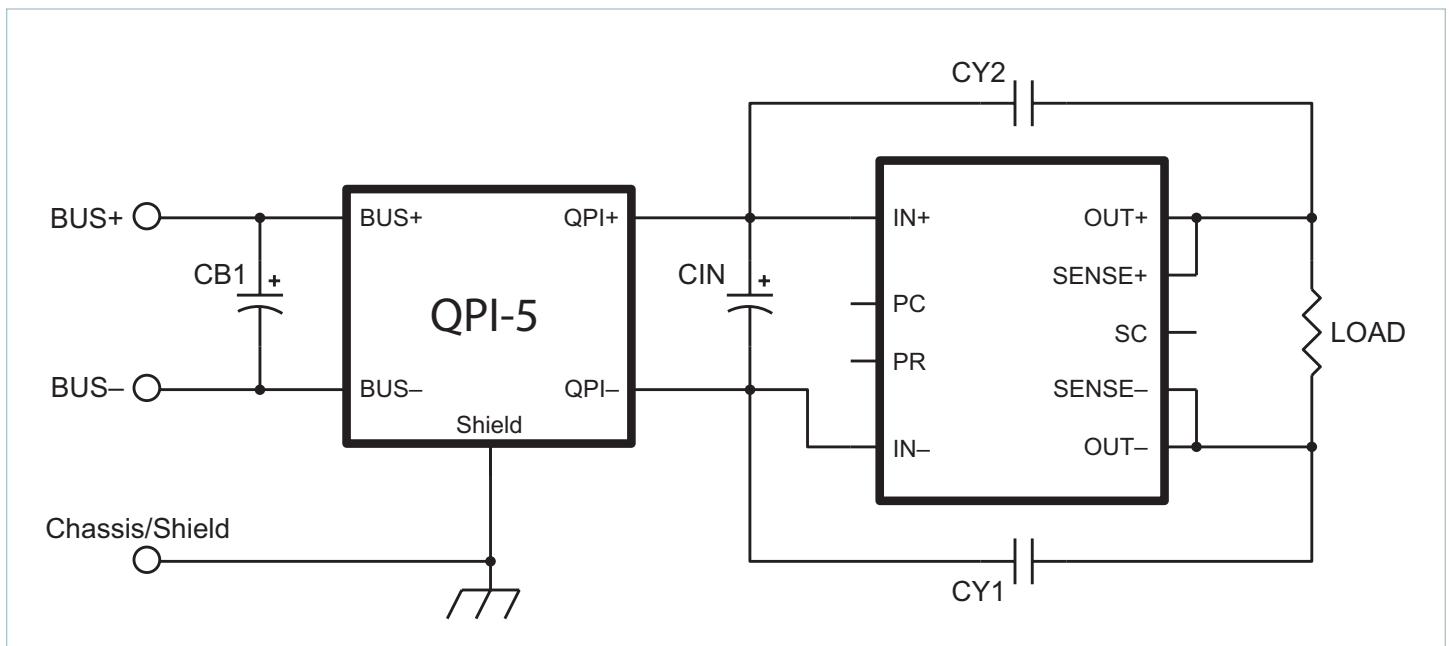

**Figure 3** — Typical ‘open-frame’ application

The typical application diagram shows the baseplate topology of re-circulating “Y” caps. Here, CY1 to CY4 are connected to each power node of the DC-DC converter, and then are commoned together on a copper shield plane created under the converter. The addition of the copper shield plane helps in the containment of the radiated EMI, converting it back to conducted EMI and shunting it back to its source.

The RY resistor, connected between the shield plane and the QPI’s shield pin, provides an impedance that makes the QPI’s common-mode noise cancellation signal more effective at removing the common-mode noise that would normally return to the shield/earth connection. It is important when laying out the QPI that the RY resistor connects to the QPI’s shield pin before making the connection to earth ground.

In Figure 3, the open-frame topology is shown where the “Y” capacitors (CY1 and CY2) re-circulate the EMI signals between the positive input and output, and the negative input and output nodes of the power-conversion stage.

Attenuation Test Set Ups

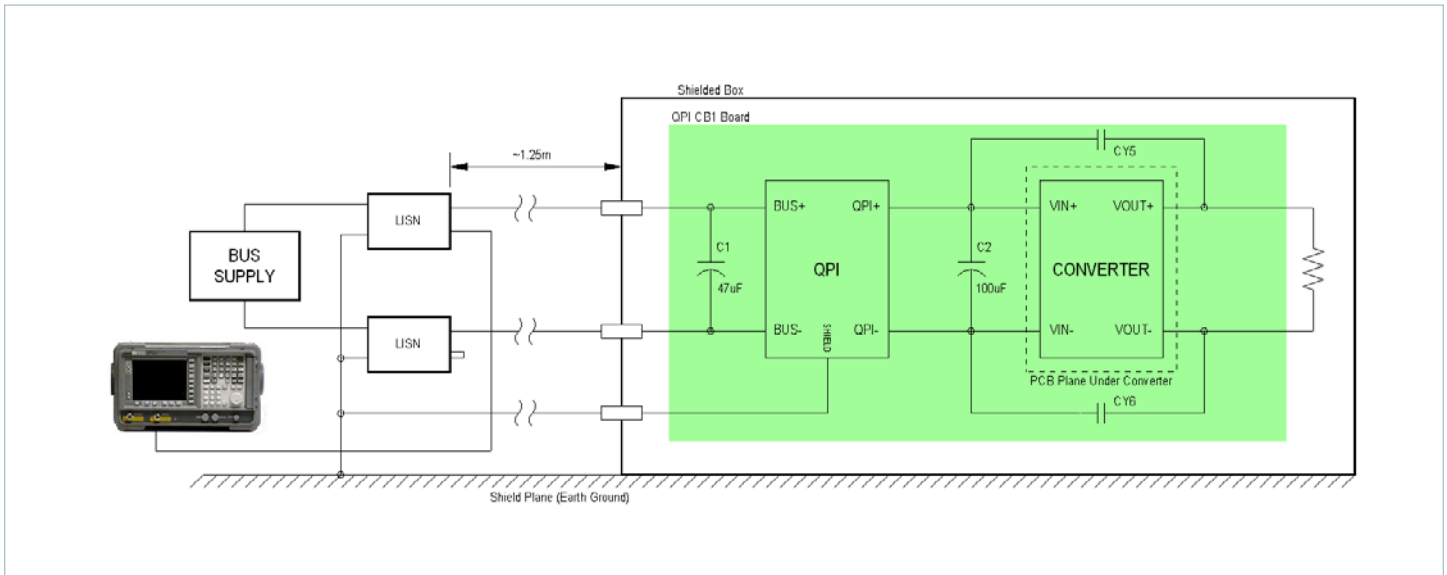

Figure 4 — Open-frame EMI test set up using the QPI-5-CB1 carrier board with 24V converter

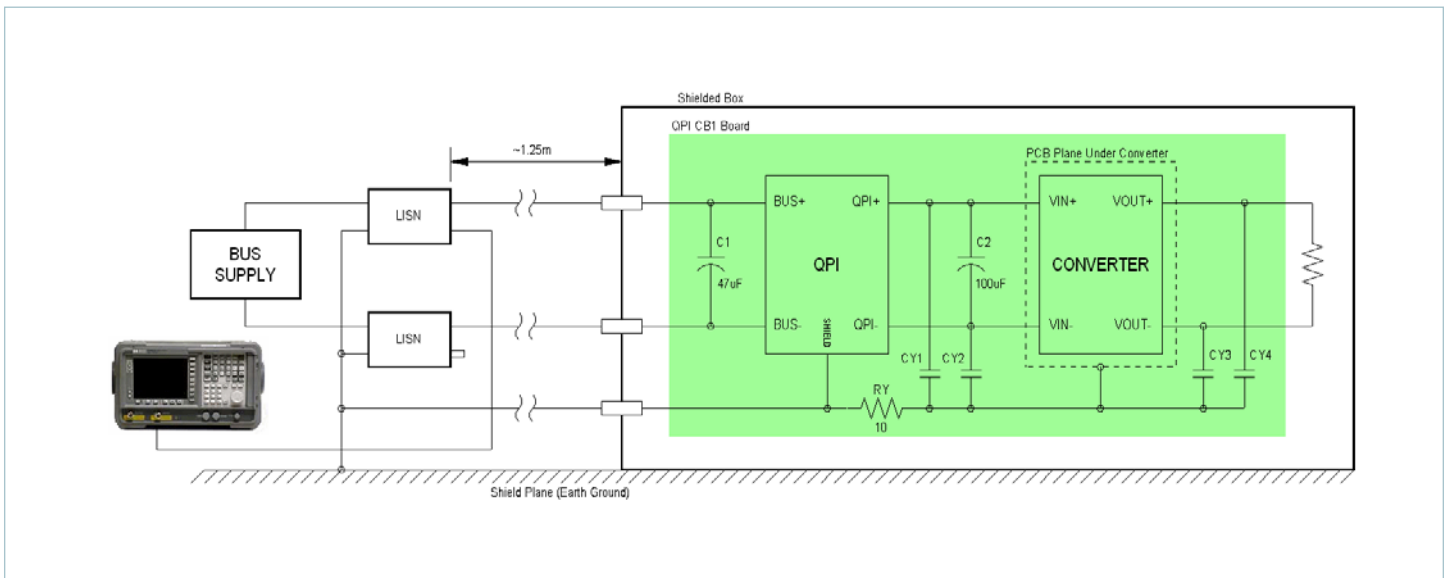

Figure 5 — Baseplate EMI test set up using the QPI-5-CB1 carrier board with 24V converter

In Figures 4 and 5, C1 is the required 47 $\mu$ F capacitor (United Chemi-Con EMVE101ARA470MKE0S or equivalent), C2 is a converter input cap (value dependant on converter), and CY caps are 4.7nF ceramic (Murata GRM31BR73A472KW01L or equivalent).

Attenuation Plots

Total EMI noise in baseplate configuration, tested as shown in Figure 5.

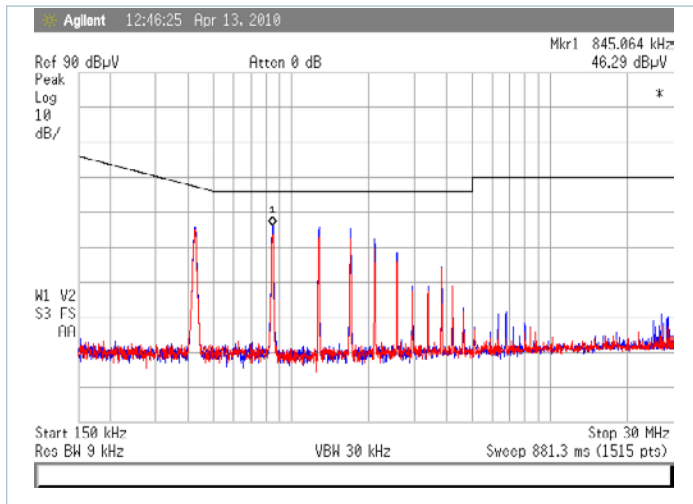

Figure 6 — V24B24C200BG using baseplate “Y” capacitors with a 171W load

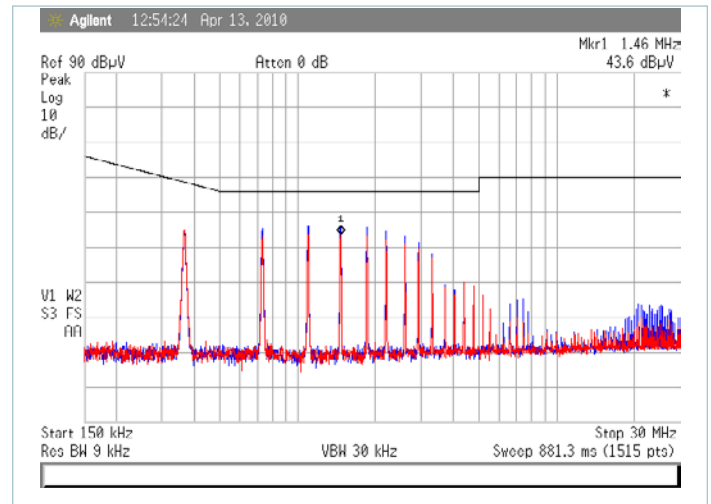

Figure 7 — V24B12C200BN using baseplate “Y” capacitors with a 136W load

Current De-Rating

Mounted to QPI-5-EVAL1 evaluation board.

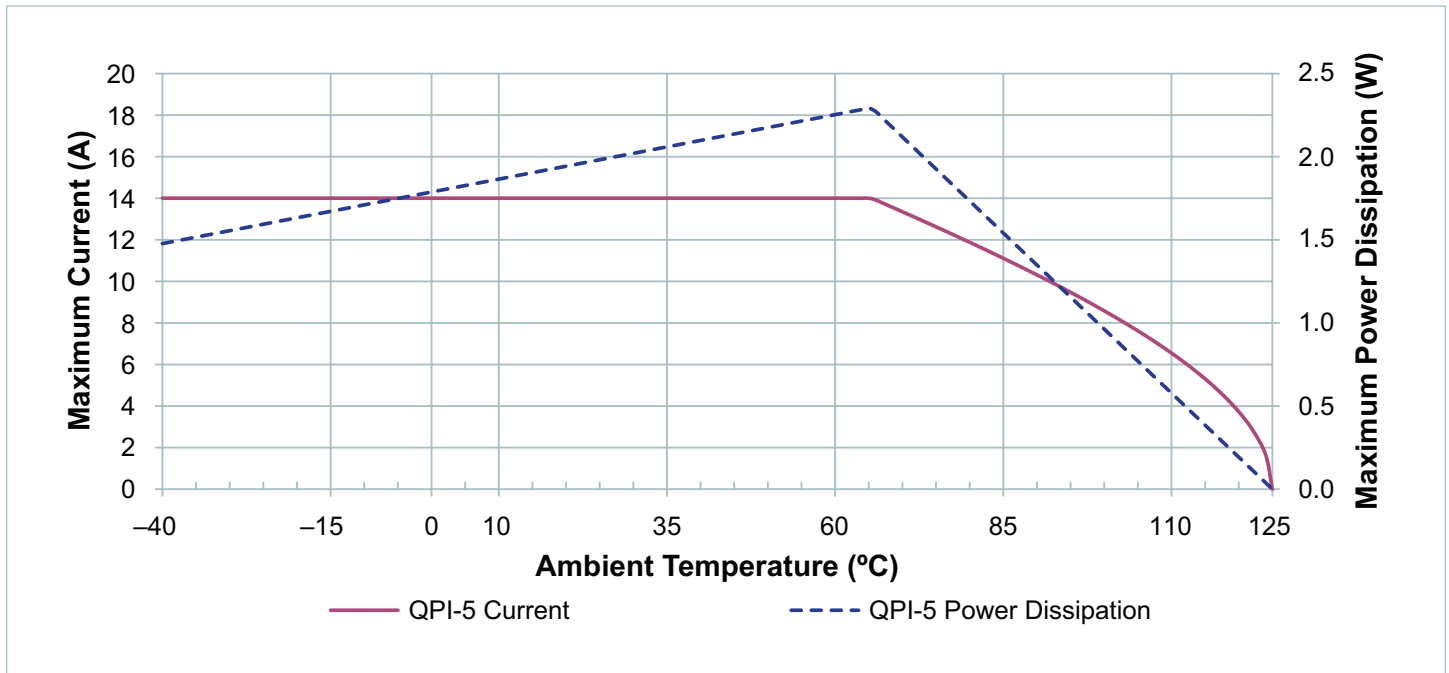

Figure 8 — Current de-rating and power dissipation over ambient temperature range

The de-rating curve in Figure 8 is based on the maximum allowable internal component temperature and the 14A maximum rating of the QPI-5. The power dissipation curve is based on the current squared multiplied by the internal resistance between the inputs and outputs of the filter. The internal resistance value is temperature compensated for the power dissipation curve. The left axis is in amps for the solid trace, the right axis is in watts for the dashed trace.



QPI Application Circuits

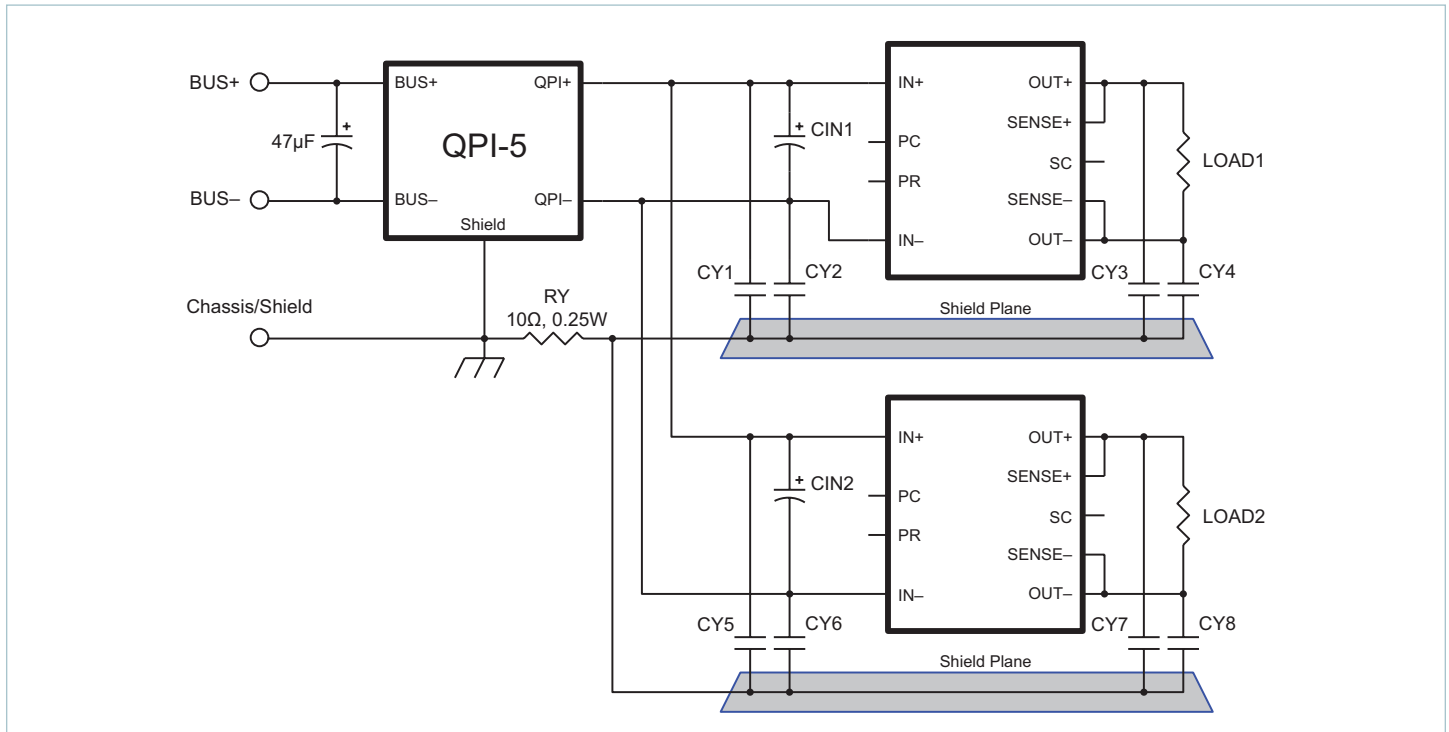

Figure 9 — The QPI-5 filtering dual supplies, using a single RY resistor<sup>[d]</sup>

The shield plane under the two converters in Figure 9 should be one contiguous plane under both. The circuit in Figure 9 is capable of filtering more converters than shown, up to the maximum current capability of the QPI-5. In Figure 10, a separate shield plane is required for each converter along with a separate RY resistor.

The QPI-5 is not designed to be used in parallel with another QPI-5 to achieve a higher current rating, but it can be used multiple times within a system design.

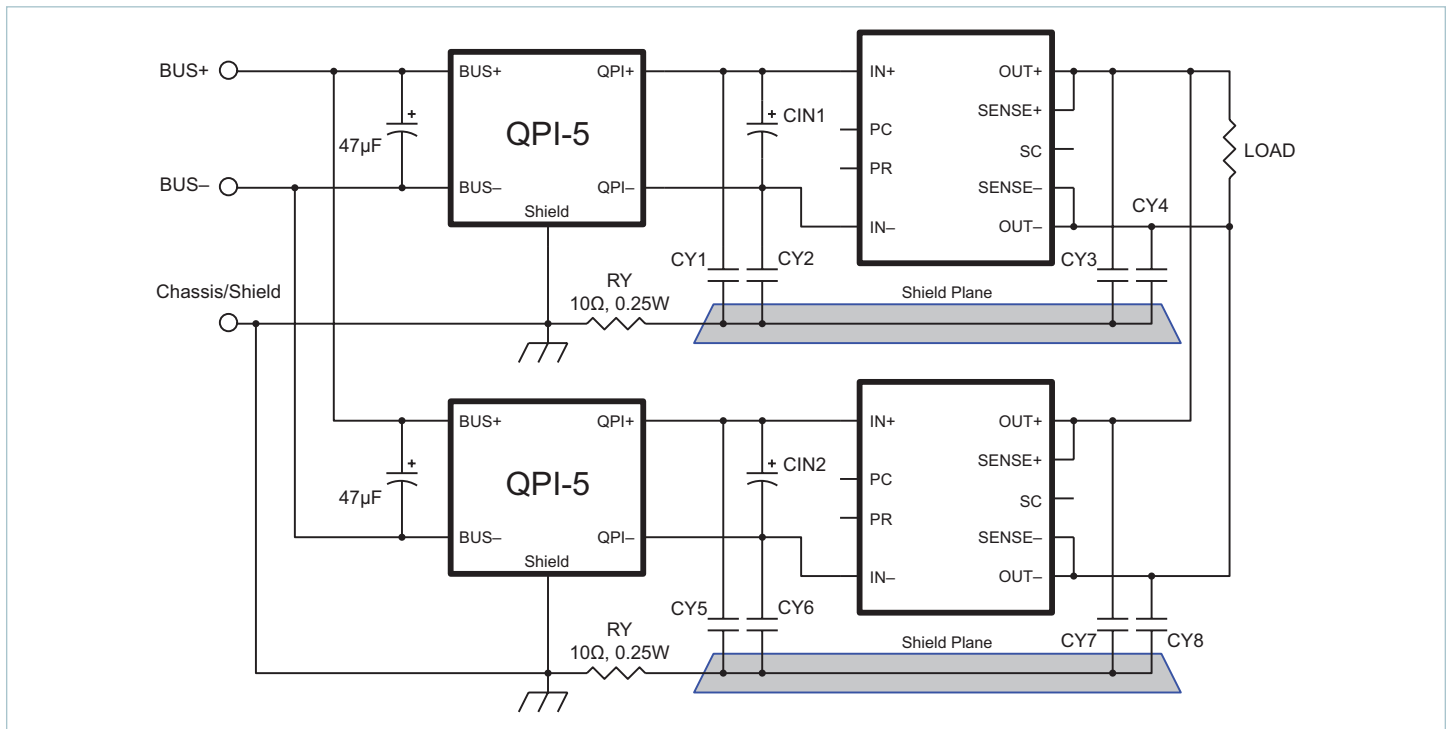

Figure 10 — Dual QPI-5's filtering paralleled converters feeding a common load<sup>[d]</sup>

<sup>[d]</sup> In Figures 9 and 10; CIN1 and CIN2, CY1 through CY8, should be the value and voltage rating recommended by the converter's manufacturer.

QPI Application Circuits (Cont.)

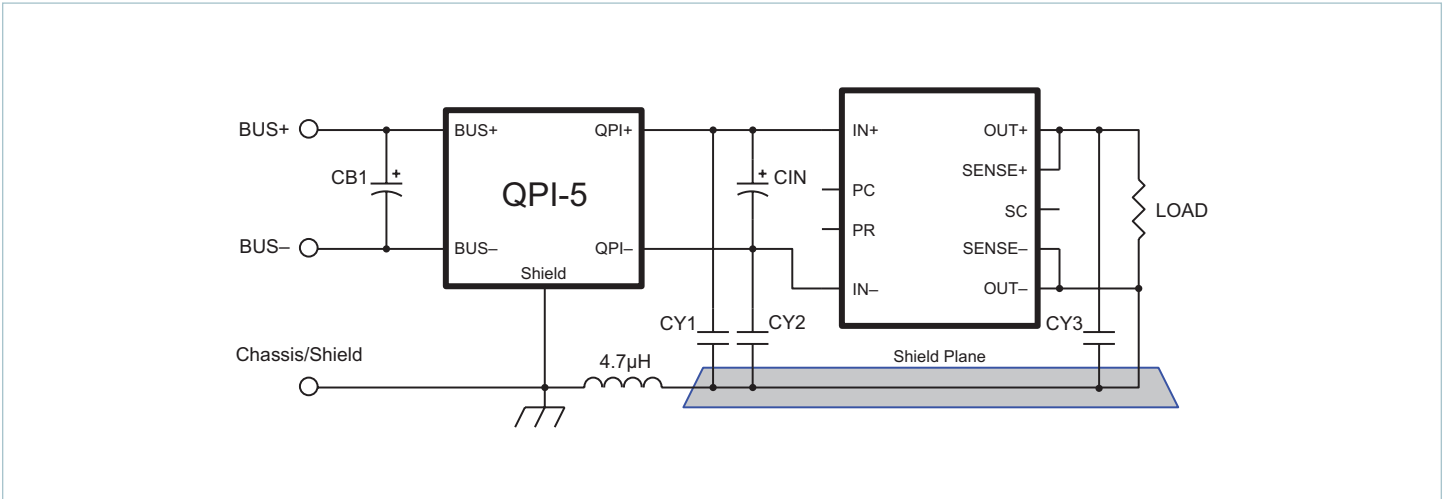

Figure 11 — Connecting the converter’s output ground to chassis through an inductor<sup>[e]</sup>

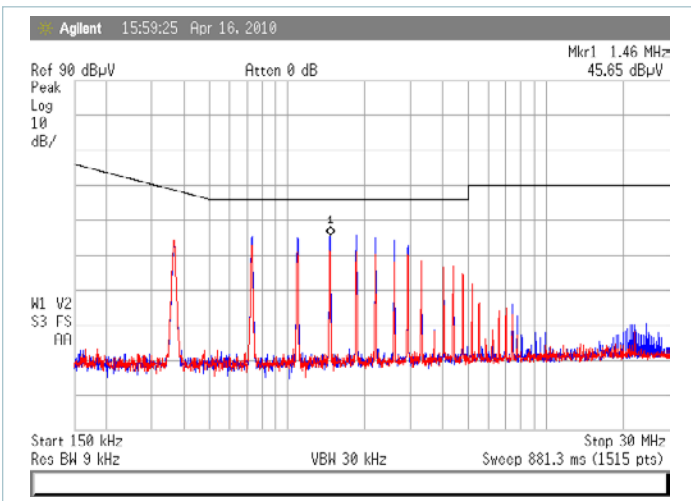

Figure 12 — Total noise V24B12C200BN with a 136W load, connected as shown in Figure 11

The direct connection of the converter’s output to the earth/chassis will degrade the EMI attenuation performance of the QPI-5. Vicor recommends that the connection to the earth be made through a series inductor, rated to the maximum output current of the converter, as shown in Figure 11. The EMI plot shown in Figure 12 is of the same converter as in Figure 6, but uses an inductor in place of RY and has the converter’s output ground connected to the shield plane.

The connection of the shield plane directly to the chassis/earth will also degrade EMI by the QPI-5 and is therefore not recommended.

<sup>[e]</sup> In Figure 12; CIN, CY1 through CY3, should be the value and voltage rating recommended by the converter’s manufacturer.

QPI Insertion Loss Measurements and Test Circuits

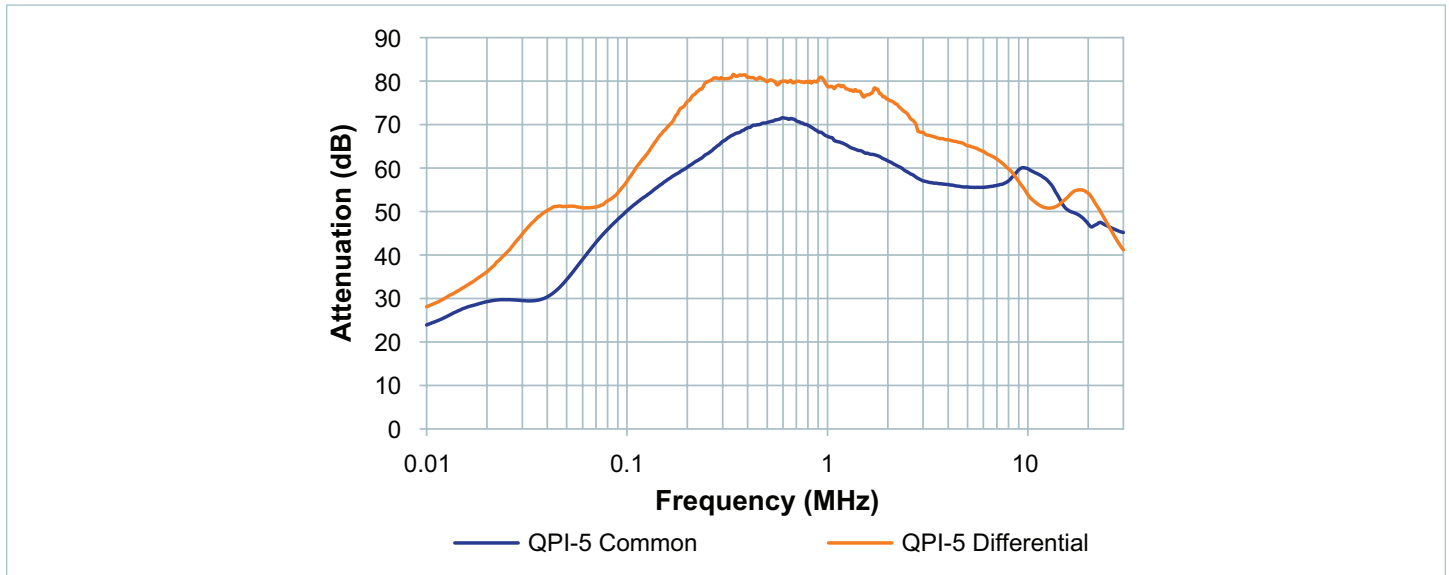

Figure 13 — Attenuation curves into a 50Ω line impedance, bias from a 28V bus

Insertion loss equation:

$$Insertion\ Loss = 20\log\left(\frac{I_{INA}}{I_{INB}}\right)$$

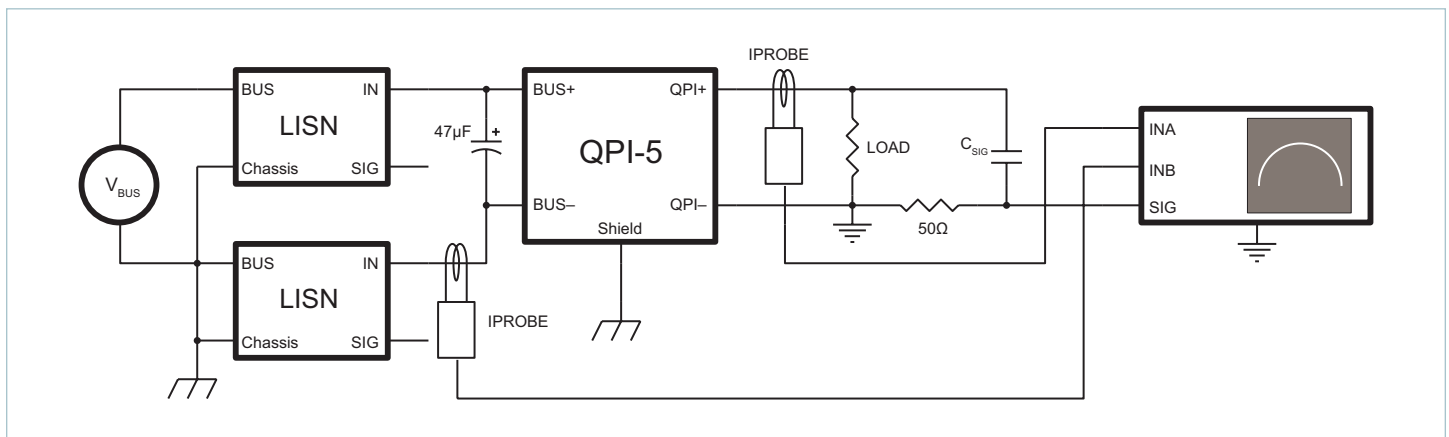

Figure 14 — Test set up to measure differential-mode EMI currents in Figure 13

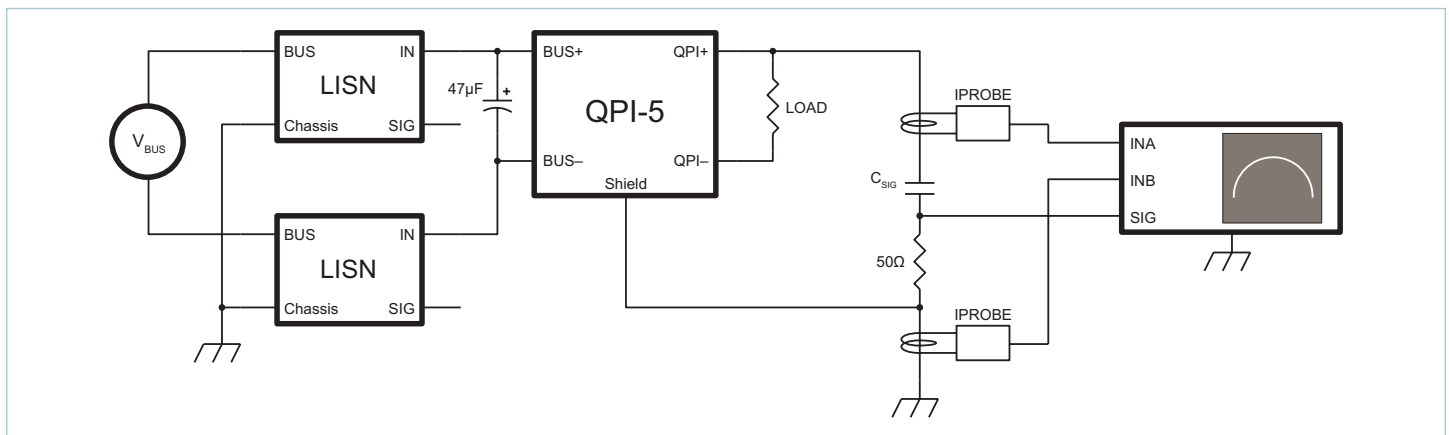

Figure 15 — Test set up to measure common-mode EMI currents in Figure 13

Package Outline Drawings

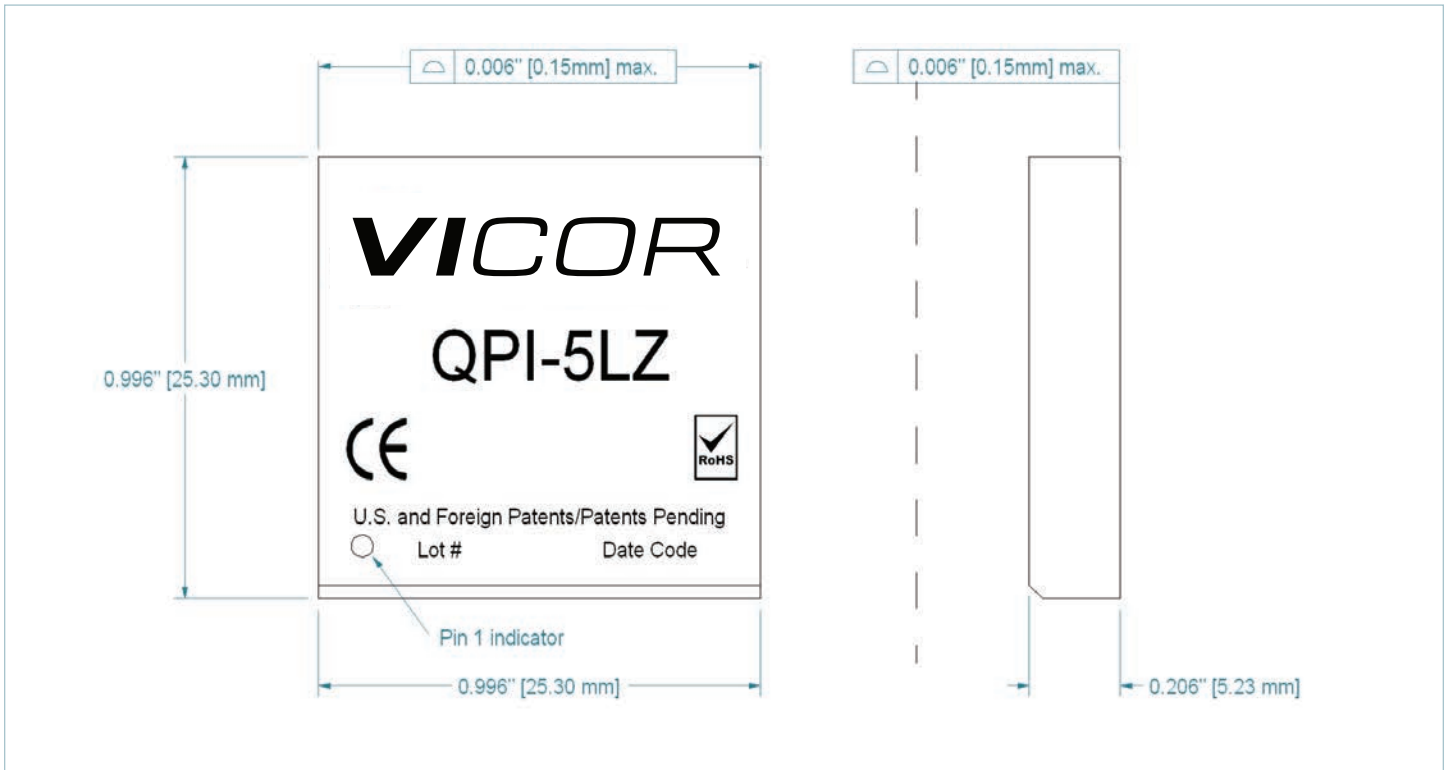

Figure 16 — Lidded package dimensions, tolerance of  $\pm 0.004$ in

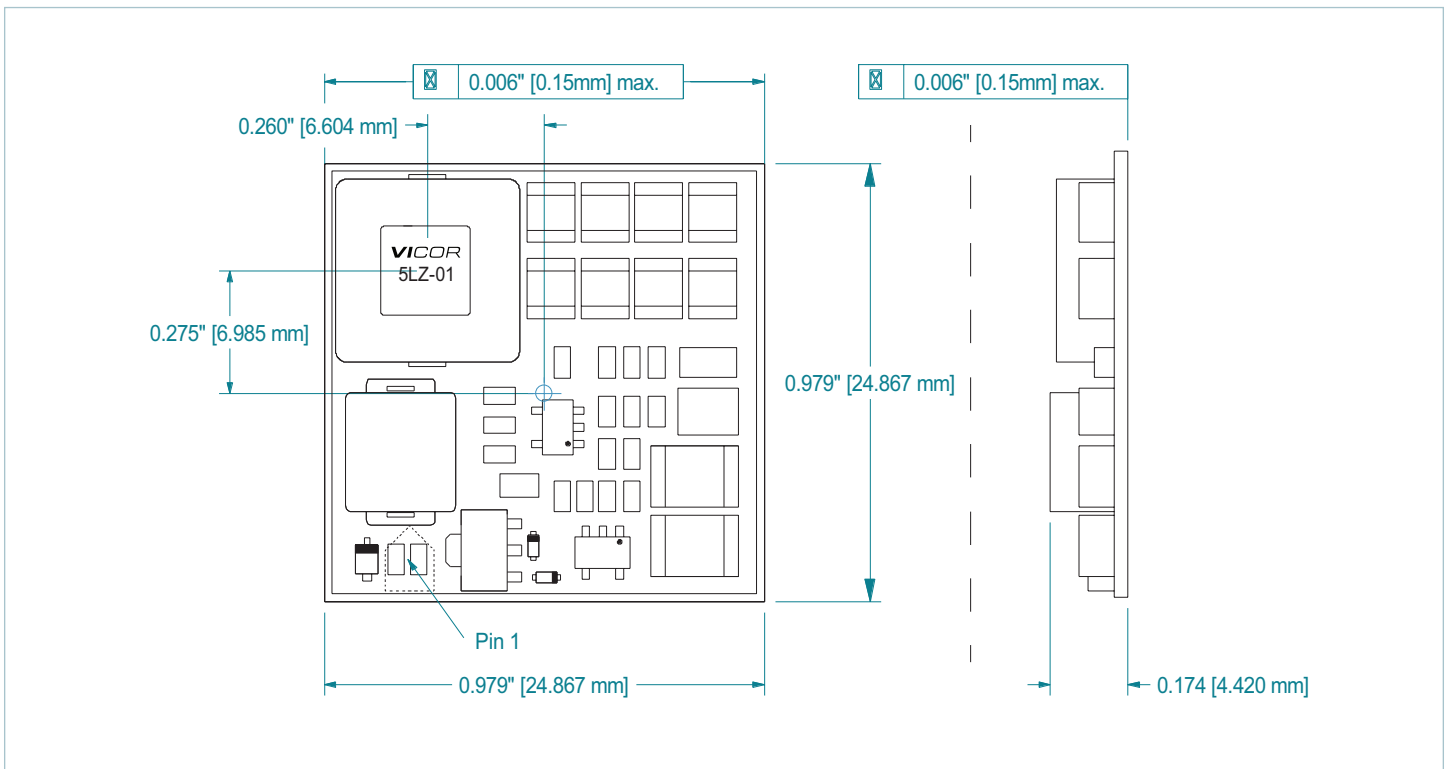

Figure 17 — Open-frame package dimensions, tolerance of  $\pm 0.004$ in; pick-and-place from label center

Pad and Stencil Definitions

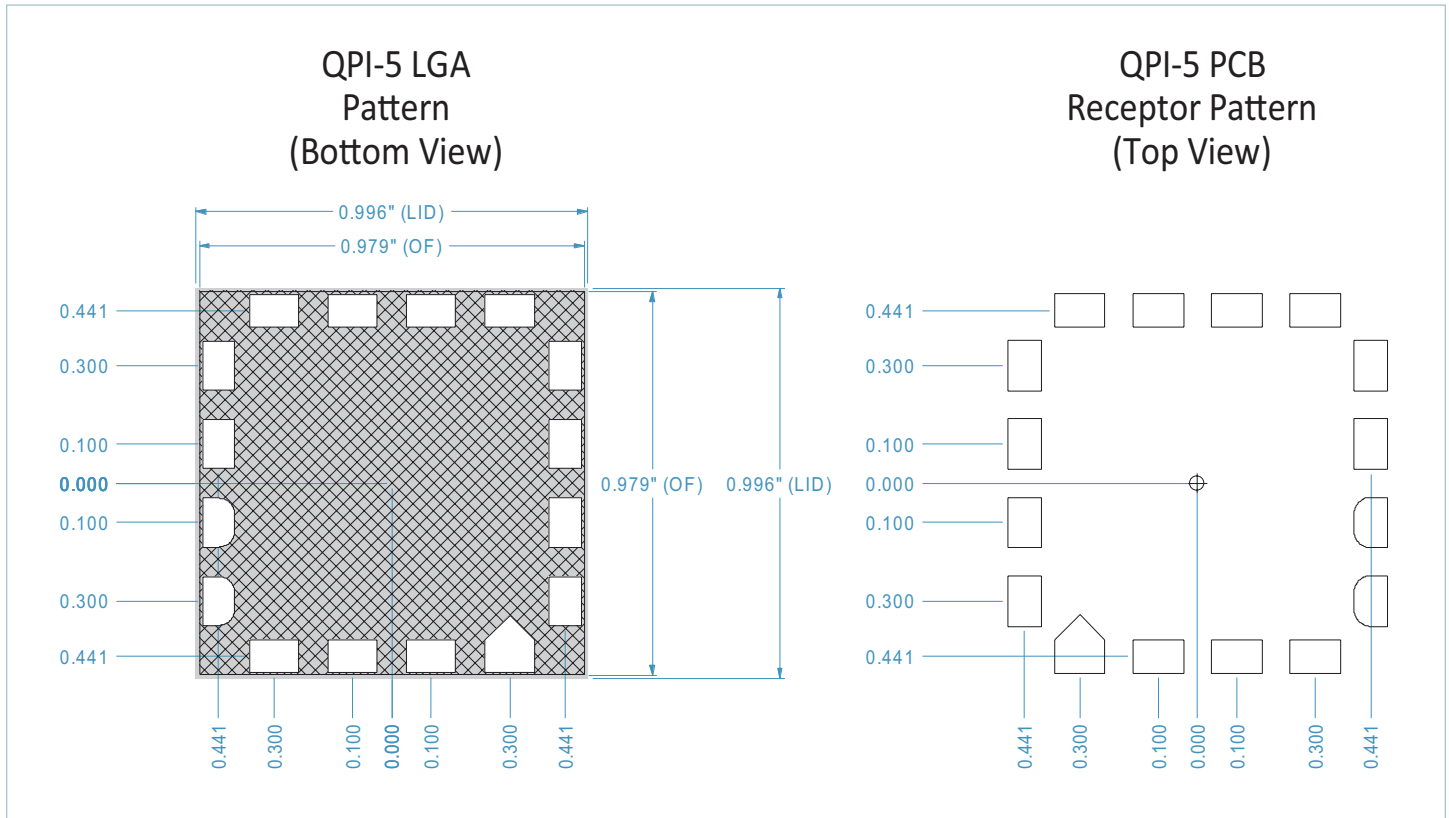

Figure 18 — Bottom view of open-frame (OF) and lidded (LID) products (all dimensions are in inches)

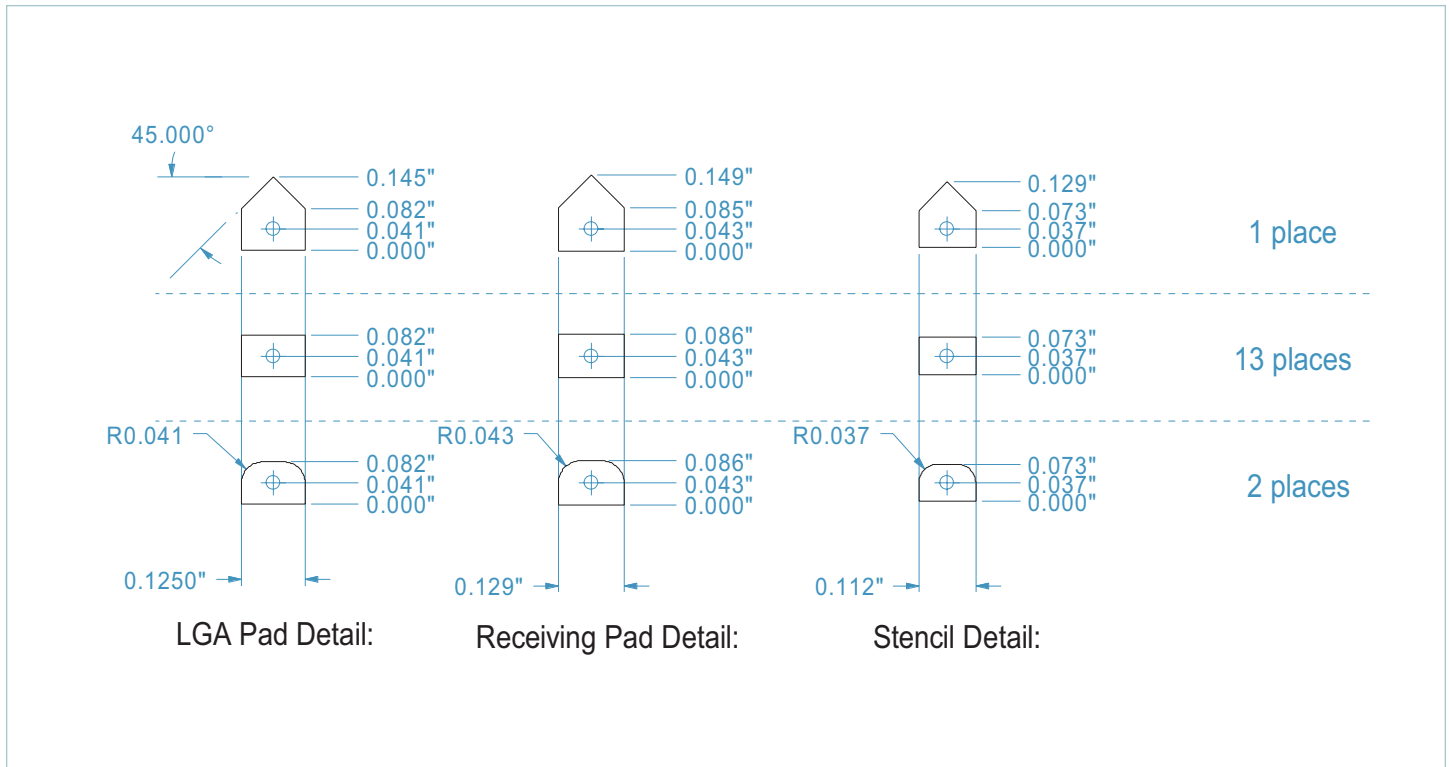

Figure 19 — Recommended receptor and stencil patterns (all dimensions are in inches)

Note: Stencil definition is based on a 6mil stencil thickness, 80% of LGA pad area coverage.  
LGA Package dimensions are for both the open-frame and lidded versions of the QPI-5.

PCB Layout Recommendations

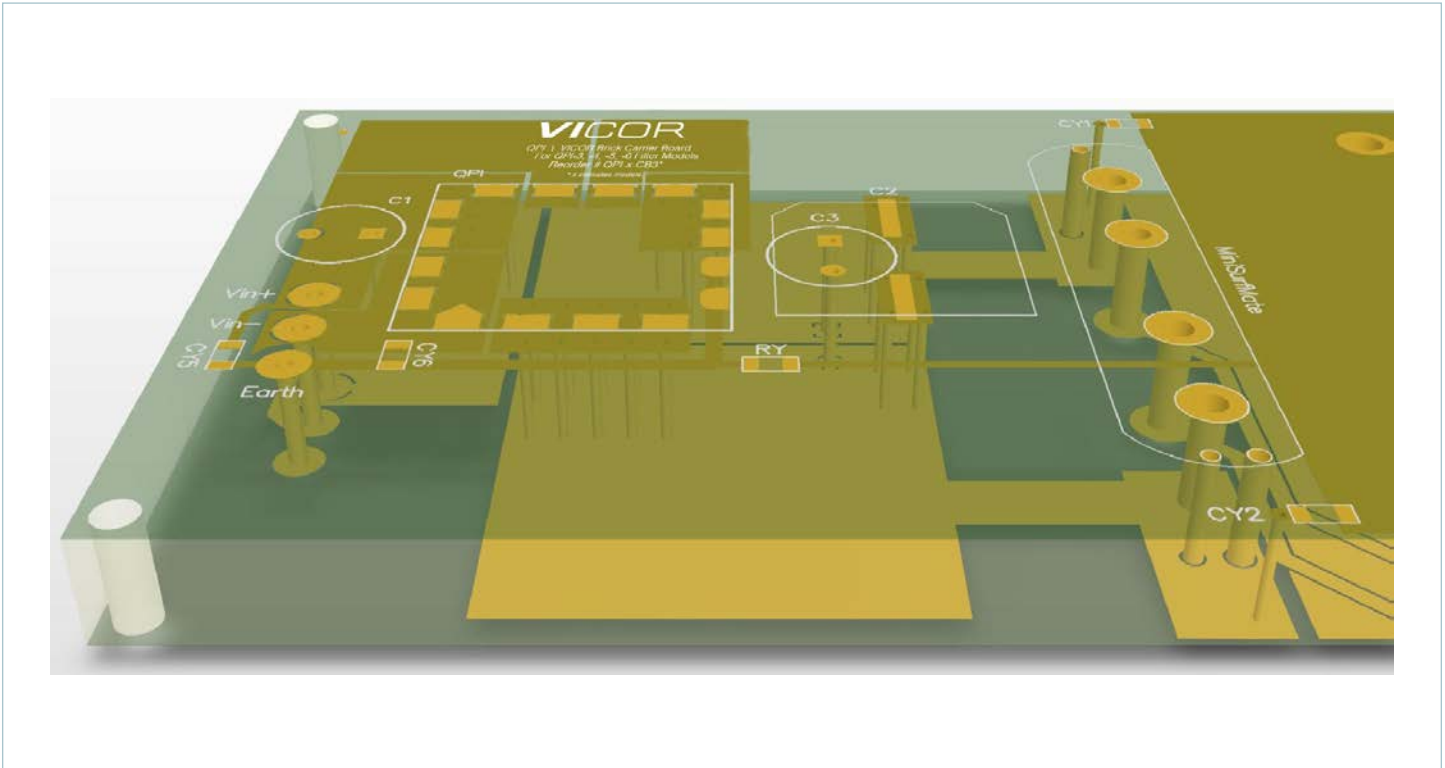

Figure 20 — 3D view of paralleling planes underneath the QPI-5

PCB Layout

When laying out the QPI-5 EMI filter it is important for the designer to be aware of the radiated EMI field that all converters emit and to place the QPI-5 outside of this field area. It is also recommended that the bus lines feeding into the QPI filter are not routed such that they lie between the QPI and the converter, or that their copper planes overlap on inner layers. This can cause EMI noise to be coupled from input to output via the parasitic capacitance between the planes.

In Figure 20, the QPI-5 is located ~1.5 inches from the converter’s input pins, and the BUS voltage pins are located on the side farthest away from the converter, to keep the radiated EMI from bypassing the filter and coupling directly to the BUS feeds.

Post-Solder Cleaning

LZ version QP SiPs are not hermetically sealed and must not be exposed to liquid, including but not limited to cleaning solvents, aqueous washing solutions or pressurized sprays. When soldering, it is recommended that no-clean flux solder be used, as this will ensure that potentially corrosive mobile ions will not remain on, around, or under the module following the soldering process. For applications where the end product must be cleaned in a liquid solvent, Vicor recommends using the QPI-5LZ-01, open-frame version of the EMI filter.

QPI-3 Mechanical Data

Datum	Units	QPI-5LZ	QPI-5LZ-01	Notes
FITS	Failure/Billion Hrs	208	208	FITS based on the BellCore Standard TR-332
MTBF	Million Hrs	4.81	4.81	MTBFs based on the BellCore Standard TR-332
Weight	grams	5.4	3.1	
MSL		3	3	
Peak Reflow Temperature	°C/20 seconds	245	245	IPC/JEDEC J-STD-020D

**Vicor's comprehensive line of power solutions includes high density AC-DC and DC-DC modules and accessory components, fully configurable AC-DC and DC-DC power supplies, and complete custom power systems.**

Information furnished by Vicor is believed to be accurate and reliable. However, no responsibility is assumed by Vicor for its use. Vicor makes no representations or warranties with respect to the accuracy or completeness of the contents of this publication. Vicor reserves the right to make changes to any products, specifications, and product descriptions at any time without notice. Information published by Vicor has been checked and is believed to be accurate at the time it was printed; however, Vicor assumes no responsibility for inaccuracies. Testing and other quality controls are used to the extent Vicor deems necessary to support Vicor's product warranty. Except where mandated by government requirements, testing of all parameters of each product is not necessarily performed.

**Specifications are subject to change without notice.**

Visit <http://www.vicorpower.com/dc-dc-filters/qpi> for the latest product information.

### **Vicor's Standard Terms and Conditions and Product Warranty**

All sales are subject to Vicor's Standard Terms and Conditions of Sale, and Product Warranty which are available on Vicor's webpage (<http://www.vicorpower.com/termsconditionswarranty>) or upon request.

### **Life Support Policy**

VICOR'S PRODUCTS ARE NOT AUTHORIZED FOR USE AS CRITICAL COMPONENTS IN LIFE SUPPORT DEVICES OR SYSTEMS WITHOUT THE EXPRESS PRIOR WRITTEN APPROVAL OF THE CHIEF EXECUTIVE OFFICER AND GENERAL COUNSEL OF VICOR CORPORATION. As used herein, life support devices or systems are devices which (a) are intended for surgical implant into the body, or (b) support or sustain life and whose failure to perform when properly used in accordance with instructions for use provided in the labeling can be reasonably expected to result in a significant injury to the user. A critical component is any component in a life support device or system whose failure to perform can be reasonably expected to cause the failure of the life support device or system or to affect its safety or effectiveness. Per Vicor Terms and Conditions of Sale, the user of Vicor products and components in life support applications assumes all risks of such use and indemnifies Vicor against all liability and damages.

### **Intellectual Property Notice**

Vicor and its subsidiaries own Intellectual Property (including issued U.S. and Foreign Patents and pending patent applications) relating to the products described in this data sheet. No license, whether express, implied, or arising by estoppel or otherwise, to any intellectual property rights is granted by this document. Interested parties should contact Vicor's Intellectual Property Department.

The products described on this data sheet are protected by U.S. Patents. Please see [www.vicorpower.com/patents](http://www.vicorpower.com/patents) for the latest patent information.

Contact Us: <http://www.vicorpower.com/contact-us>

**Vicor Corporation**  
25 Frontage Road  
Andover, MA, USA 01810  
Tel: 800-735-6200  
Fax: 978-475-6715  
[www.vicorpower.com](http://www.vicorpower.com)

#### **email**

Customer Service: [custserv@vicorpower.com](mailto:custserv@vicorpower.com)  
Technical Support: [apps@vicorpower.com](mailto:apps@vicorpower.com)

# Mouser Electronics

Authorized Distributor

Click to View Pricing, Inventory, Delivery & Lifecycle Information:

[Vicor:](#)

[QPI-5-CB1](#)