

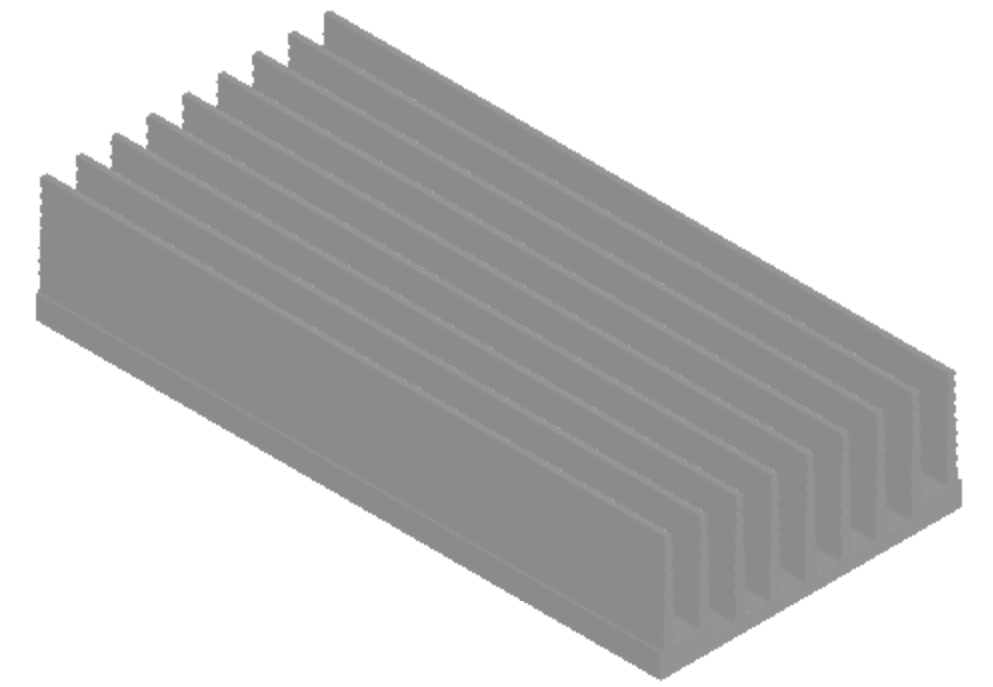

VICOR CONFIDENTIAL  
 THIS DOCUMENT AND THE DATA DISCLOSED HEREIN OR  
 HEREWITH IS NOT TO BE REPRODUCED, USED OR  
 DISCLOSED IN WHOLE OR IN PART TO ANYONE WITHOUT  
 THE PERMISSION OF VICOR CORP.

| REV. | DESCRIPTION          | DATE         | APPROVED |
|------|----------------------|--------------|----------|
| 4    | RELEASED PER E090033 | AR 01/09/09  | REJH     |
| 5    | REVISED PER E092035  | JS 11/16/09  | REJH     |
| 6    | REDRAWN PER E100871  | DCS 06/31/10 | KUK      |
| 7    | REVISED PER E111266  | VSS 12/22/11 | REJH     |

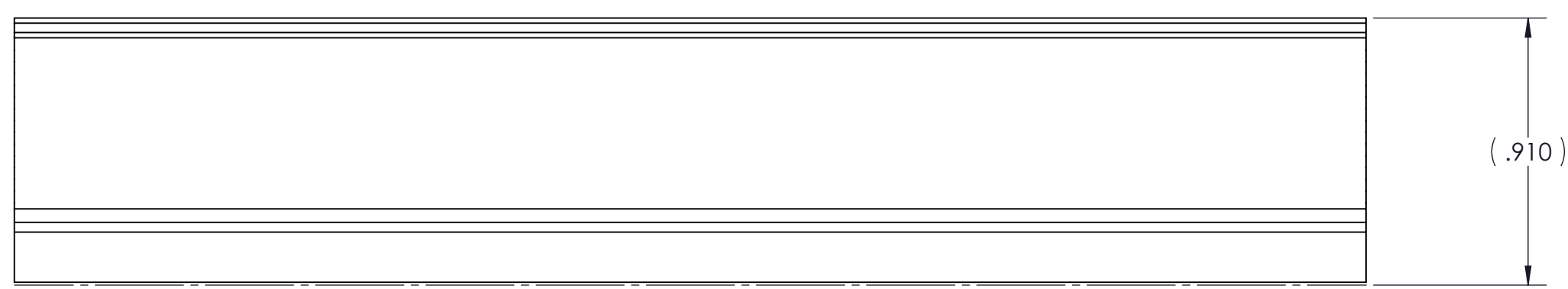
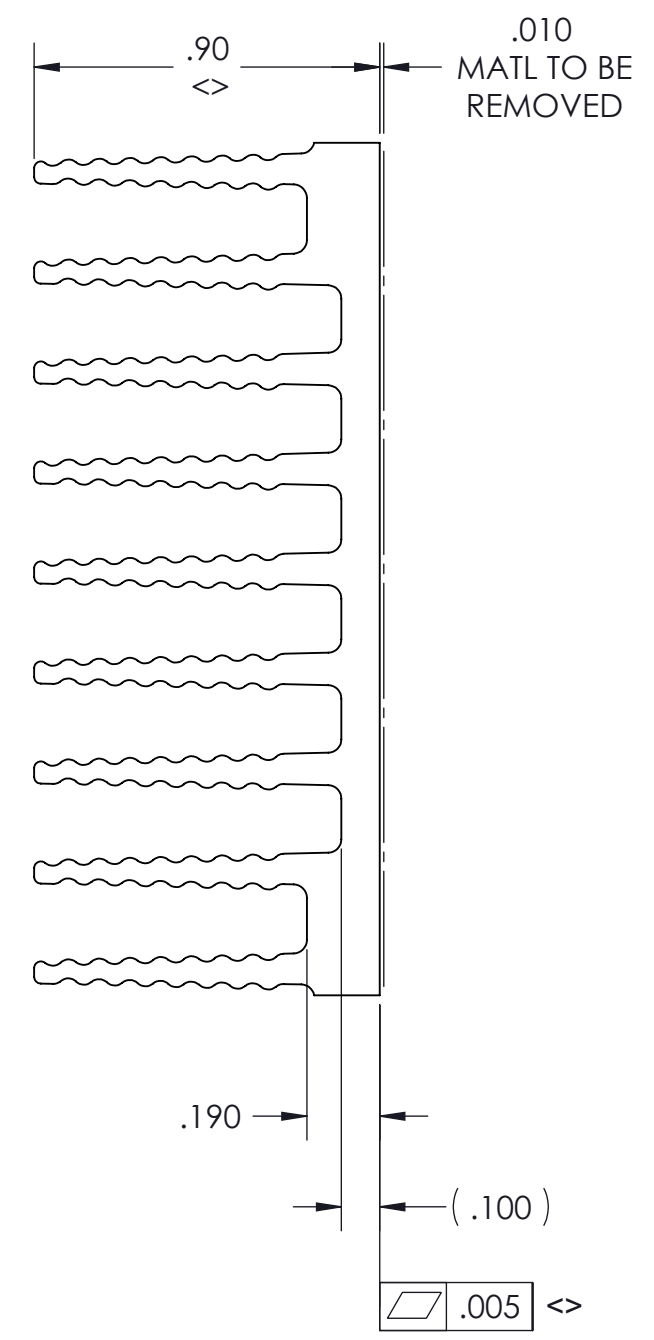
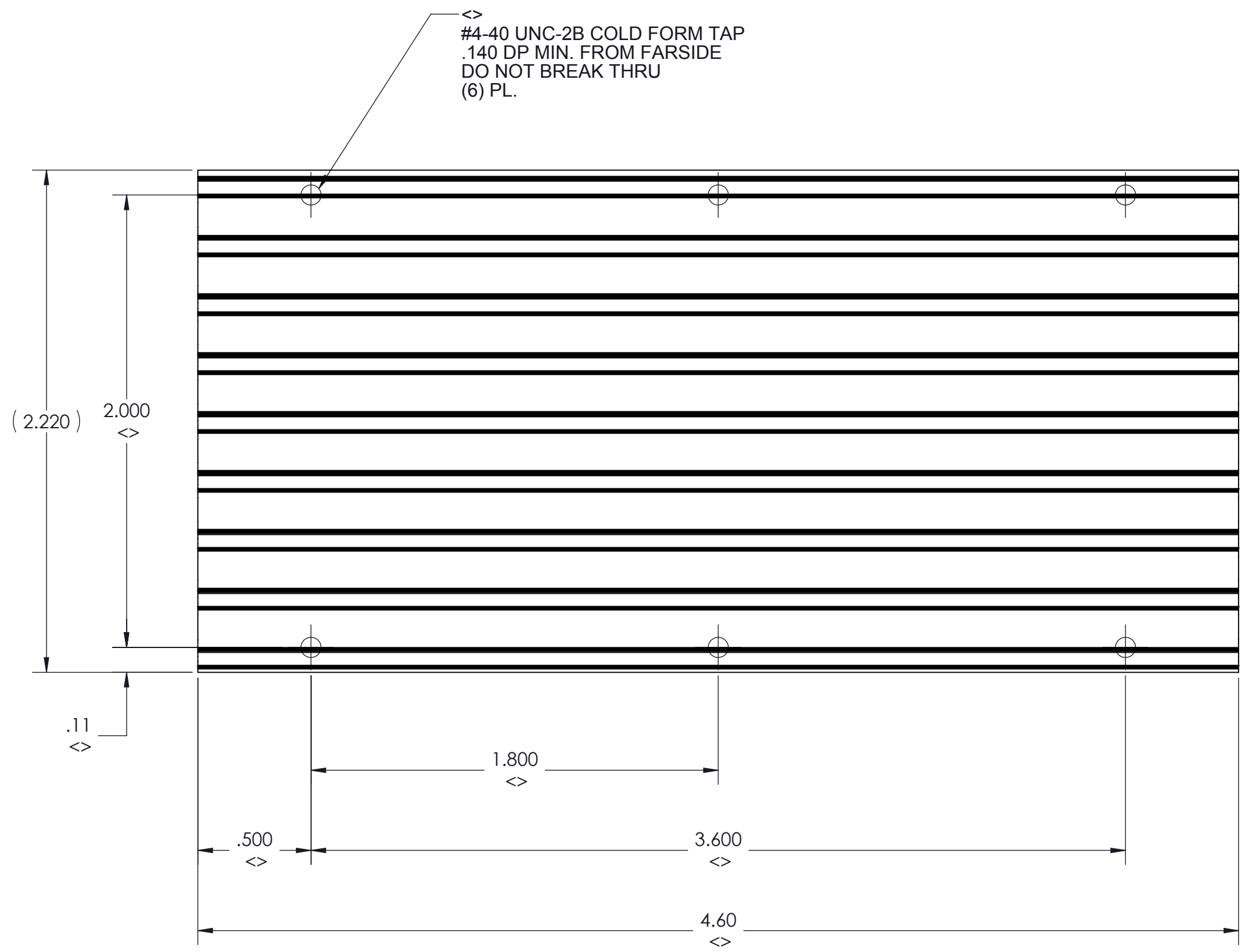

- NOTES:
1. MATERIAL: EXTRUSION SEE SHEET 2 OF 2
  2. REMOVE ALL BURRS AND SHARP EDGES.
  3. CLEAR FINISH, RoHS COMPLAINT PER CST-0001, LATEST REVISION PER  
 A) CHROMIUM FREE, OR  
 B) TRIVALENT CHROMIUM IN ACCORDANCE WITH MIL-DTL-5541, TYPE II, CLASS 1A OR 3.  
 SEE CST-0003 FOR TYPES OF AVAILABLE FINISHES.
  4. "<>" DENOTES CRITICAL CHARACTERISTIC FOR LOT INSPECTION.
  5. DIMENSIONS ARE INCHES ONLY.

|   |                    |  |                           |                        |                 |
|---|--------------------|--|---------------------------|------------------------|-----------------|
| DRAWN BY<br>David Schmidt   | DATE<br>06/30/2010 | <b>VICOR</b> SWD                         |                           |                        |                 |
| UNLESS OTHERWISE SPECIFIED<br>DIMENSIONS ARE : INCH / (MM)  |                    | <b>HTSNK "A" LONG .9H LO FLO<br/>THD</b> |                           |                        |                 |
| TOLERANCES ARE:<br>DECIMALS ANGLES<br>X.XX [X.X] = ±0.01 [0.25] ±1°<br>X.XXX [X.XX] = ±0.005 [0.127]                                    |                    | SIZE<br><b>C</b>                         | CAGE CODE<br><b>67131</b> | DWG NO<br><b>30188</b> | REV<br><b>7</b> |
| THIRD ANGLE PROJECTION<br><br>DO NOT SCALE DRAWING |                    | SCALE 1:1                                |                           | SHEET 1 OF 2           |                 |

8

7

6

5

4

3

2

1

VICOR CONFIDENTIAL  
 THIS DOCUMENT AND THE DATA DISCLOSED HEREIN OR  
 HEREWITH IS NOT TO BE REPRODUCED, USED OR  
 DISCLOSED IN WHOLE OR IN PART TO ANYONE WITHOUT  
 THE PERMISSION OF VICOR CORP.

| REV. | DESCRIPTION      | DATE | APPROVED |
|------|------------------|------|----------|
|      | SEE SHEET 1 OF 2 |      |          |

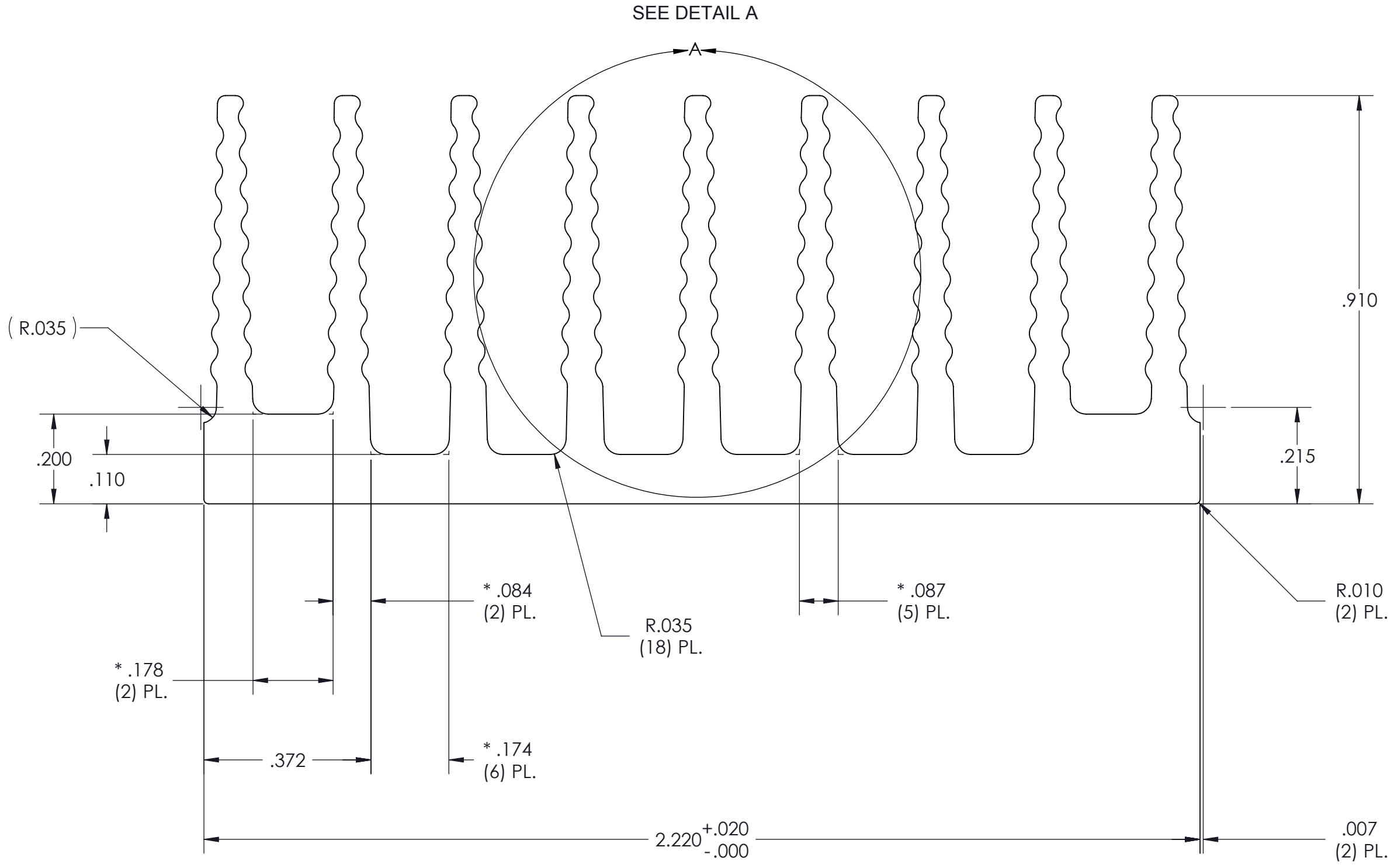

| PROFILE COMMON FOR |
|--------------------|
| 30123              |
| 30181              |
| 30189              |
| 30182              |
| 30188              |

- NOTES:
1. MATERIAL: ALUMINUM 6063-T5
  2. \* DENOTES DIMENSION TO THEORETICAL SHARP CORNER.
  3. ALL DIMENSIONS ARE CRITICAL CHARACTERISTICS.
  4. RoHS COMPLIANT PER CST-0001 LATEST REVISION.
  5. WORKMANSHIP STANDARDS WS-0004, WS-0006, AND WS0007 APPLY TO THIS PART.
  6. DIMENSIONS ARE INCHES ONLY.

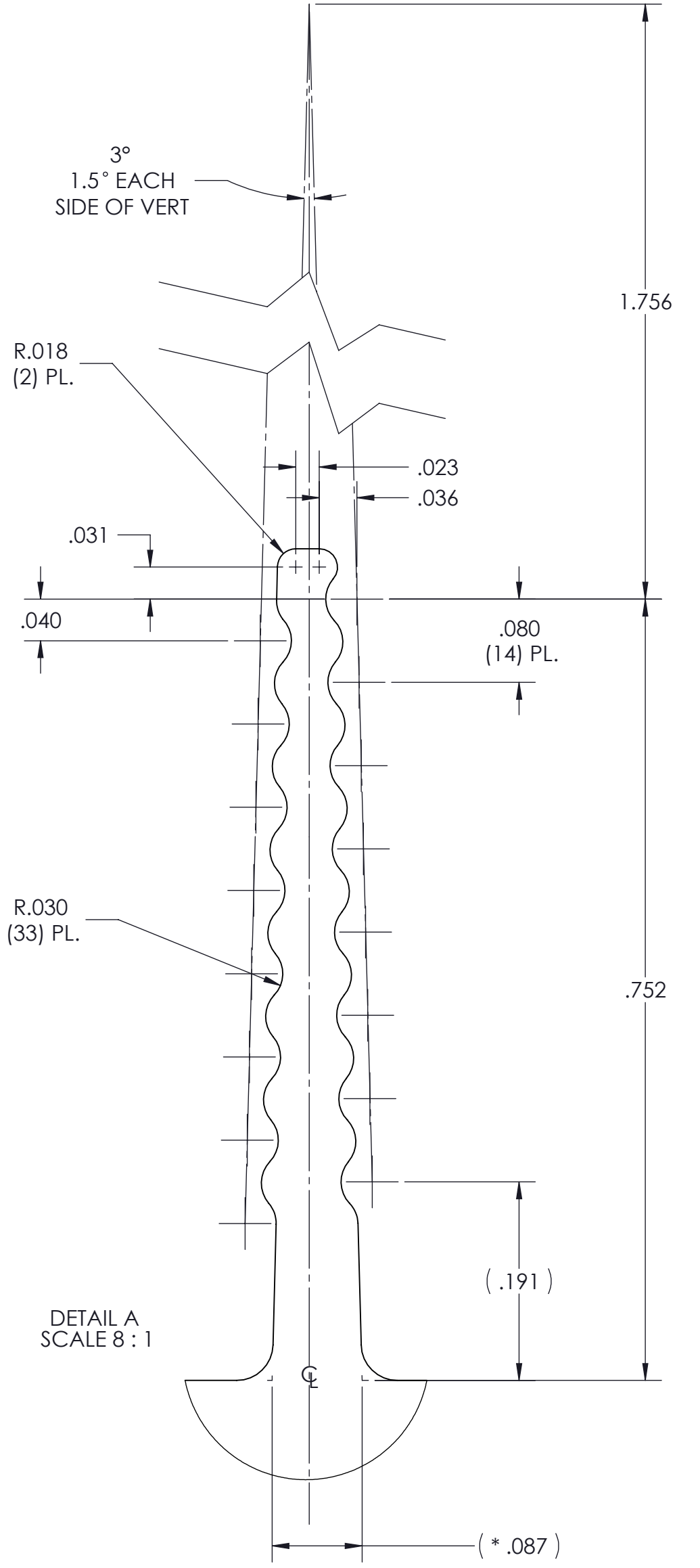

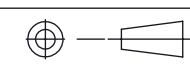
|  |                    |                                      |                           |                        |
|--|--------------------|--------------------------------------|---------------------------|------------------------|
| DRAWN BY<br>David Schmidt  | DATE<br>06/30/2010 | <b>VICOR</b> SWD                     |                           |                        |
| UNLESS OTHERWISE SPECIFIED<br>DIMENSIONS ARE : INCH / [MM]   |                    | <b>HTSNK "A" LONG .9H LO FLO THD</b> |                           |                        |
| TOLERANCES ARE:<br>DECIMALS                      ANGLES<br>X.XX [X.X] = ±0.01 [0.25]                      ±1°<br>X.XXX [X.XX] = ±0.005 [0.127] |                    | SIZE<br><b>C</b>                     | CAGE CODE<br><b>67131</b> | DWG NO<br><b>30188</b> |
| THIRD ANGLE PROJECTION<br>                                |                    | REV<br><b>7</b>                      | SCALE 1:1<br>SHEET 2 OF 2 |                        |

8

7

6

5

4

3

2

1

# Mouser Electronics

Authorized Distributor

Click to View Pricing, Inventory, Delivery & Lifecycle Information:

[Vicor:](#)

[30188](#)