

HCLC Series

High Current Low Core Loss Toroidal Inductors

HCLC Series of High Current Low Core Loss Toroidal Inductors are vertical PCB THT mounted magnetics with a broad inductance and current range. HCLC parts are constructed with a specific core material enabling them to exhibit higher energy storage, great temperature stability and a very low magnetostriction for reduced audible noise.

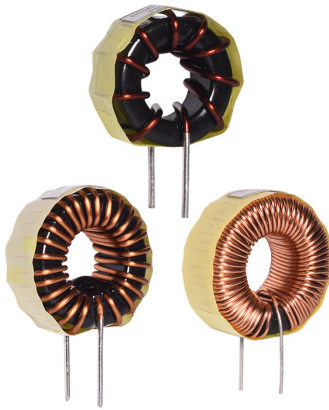

General Features

- Vertical PCB mounting for board layout optimization
- High efficiency with low core loss
- Distributed air gap for high energy storage
- Self-shielding for low magnetic radiation
- High current carrying capability

Specifications

- Inductance Range: 10 μH to 1000 μH
- Max. DC Resistance: 0.006 Ω to 0.216 Ω
- I-rated DC Current: 2.4 A to 14.3 A
- Operating Temperature Range: -55°C to +125°C

Applications

- SMPS
- EMI/RFI filtering
- Converters
- Inverters
- Amplifiers

Markets

- Telecom
- Medical
- Commercial
- Industrial
- Security

PRODUCT IDENTIFICATION

HCLC - 33 - 11.1

Type / Product Series

HCLC = High Current Low Core Loss Toroidal Inductors

I-rated DC Current

11.1 = 11.1 A

Inductance

33 = 33 μ H

MECHANICAL SPECIFICATIONS

Dimensions are in inches.

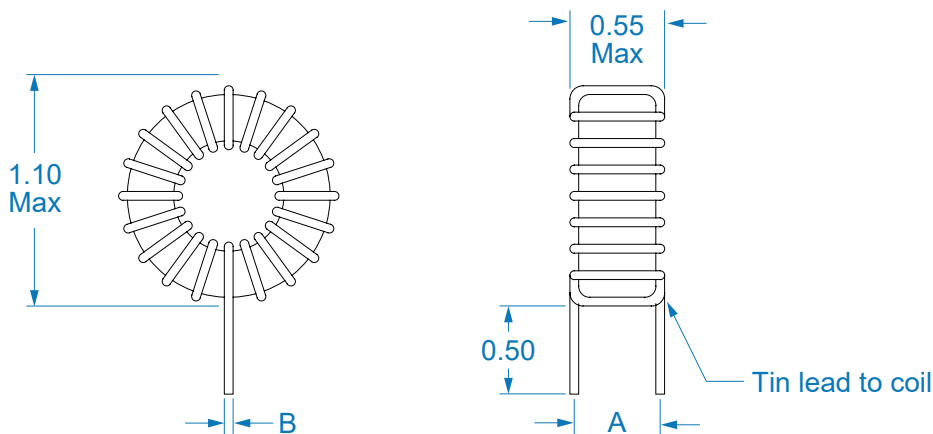

Custom versions available upon request.



128 Atlantic Avenue, Lynbrook, NY 11563
Toll Free 866-239-5777 | Tel 516-239-5777 | Fax 516-239-7208
sales@signaltransformer.com | techhelp@signaltransformer.com

belfuse.com/signal

ELECTRO-MECHANICAL SPECIFICATIONS

Part Number	L ± 15% @ 1 kHz (μH)	L ± 15% @ I-rated (μH)	DC Resistance Max. (Ω)	I-rated DC Current ¹ (A)	Dimension Nominal A (in)	Dimension Nominal B (in)
HCLC-10-14.3	10	6.0	0.006	14.3	0.47	0.053
HCLC-12-14.2	12	6.9	0.006	14.2	0.47	0.053
HCLC-15-13.6	15	8.3	0.007	13.6	0.47	0.053
HCLC-18-13.1	18	9.7	0.007	13.1	0.47	0.053
HCLC-22-12.6	22	11.5	0.008	12.6	0.47	0.053
HCLC-27-11.8	27	13.5	0.009	11.8	0.47	0.053
HCLC-33-11.1	33	15.7	0.010	11.1	0.47	0.053
HCLC-39-10.8	39	18.1	0.011	10.8	0.47	0.053
HCLC-47-10.3	47	20.9	0.012	10.3	0.47	0.053
HCLC-56-9.8	56	23.9	0.013	9.8	0.47	0.053
HCLC-68-7.6	68	33.9	0.022	7.6	0.45	0.042
HCLC-82-7.1	82	39.0	0.024	7.1	0.45	0.042
HCLC-100-6.8	100	45.6	0.027	6.8	0.45	0.042
HCLC-120-5.1	120	63.4	0.047	5.1	0.43	0.034
HCLC-150-4.9	150	76.0	0.052	4.9	0.43	0.034
HCLC-180-4.7	180	88.5	0.057	4.7	0.43	0.034
HCLC-220-4.4	220	103.1	0.063	4.4	0.43	0.034
HCLC-270-4.2	270	121.1	0.070	4.2	0.43	0.034
HCLC-330-4.0	330	141.9	0.077	4.0	0.43	0.034
HCLC-390-3.8	390	161.2	0.084	3.8	0.43	0.034
HCLC-470-3.7	470	185.7	0.092	3.7	0.43	0.034
HCLC-560-3.5	560	212.0	0.101	3.5	0.43	0.034
HCLC-680-2.7	680	307.6	0.176	2.7	0.47	0.027
HCLC-820-2.5	820	355.5	0.194	2.5	0.47	0.027
HCLC-1000-2.4	1000	412.5	0.216	2.4	0.47	0.027

¹ The current causing 30°C max. temperature rise.

Custom versions available upon request.



128 Atlantic Avenue, Lynbrook, NY 11563
 Toll Free 866-239-5777 | Tel 516-239-5777 | Fax 516-239-7208
 sales@signaltransformer.com | techhelp@signaltransformer.com

belfuse.com/signal

RECOMMENDED WAVE SOLDERING CONDITIONS

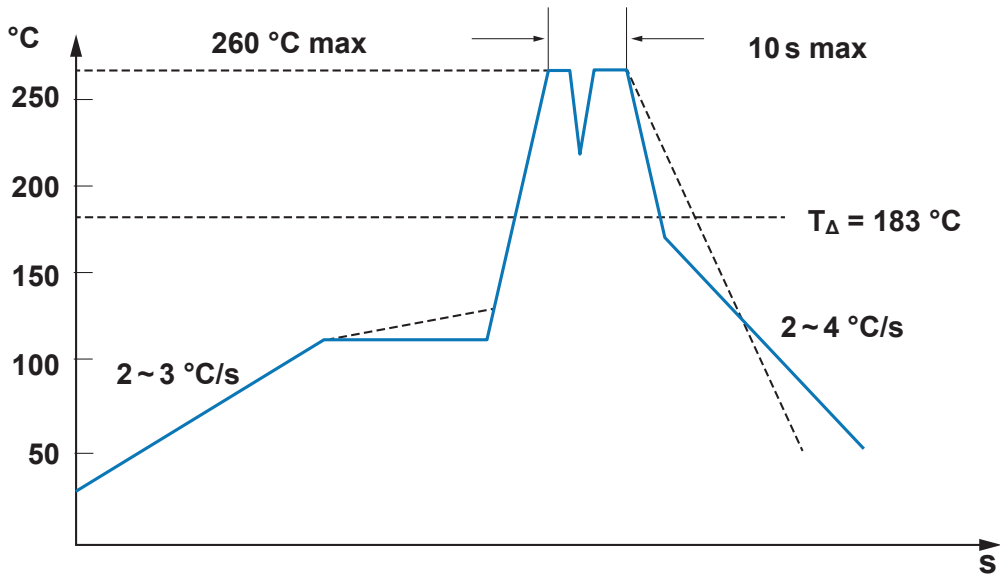

- Note**
 Product soldering processing conditions and set methods may vary due to differences between various manufactures and their equipment. Adjustments are to be made accordingly.

PACKAGING SPECIFICATIONS

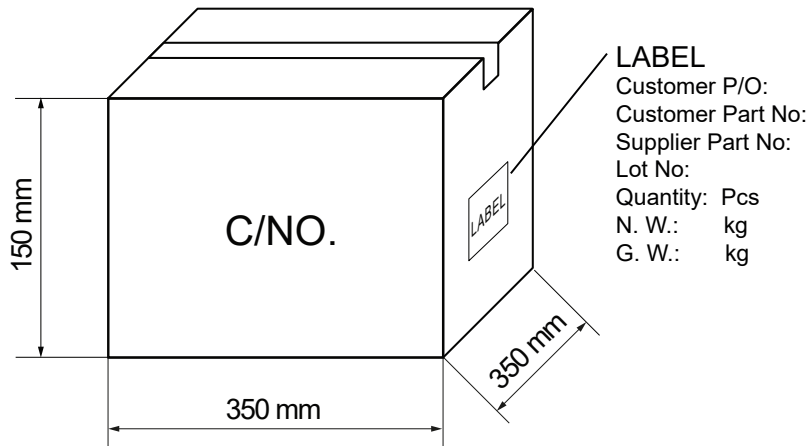

Series	Packaging Quantity (pcs)		
	per Tray	Trays per Carton	Total Quantity per Carton
HCLC	70	7	490

Custom versions available upon request.



128 Atlantic Avenue, Lynbrook, NY 11563
 Toll Free 866-239-5777 | Tel 516-239-5777 | Fax 516-239-7208
 sales@signaltransformer.com | techhelp@signaltransformer.com

belfuse.com/signal

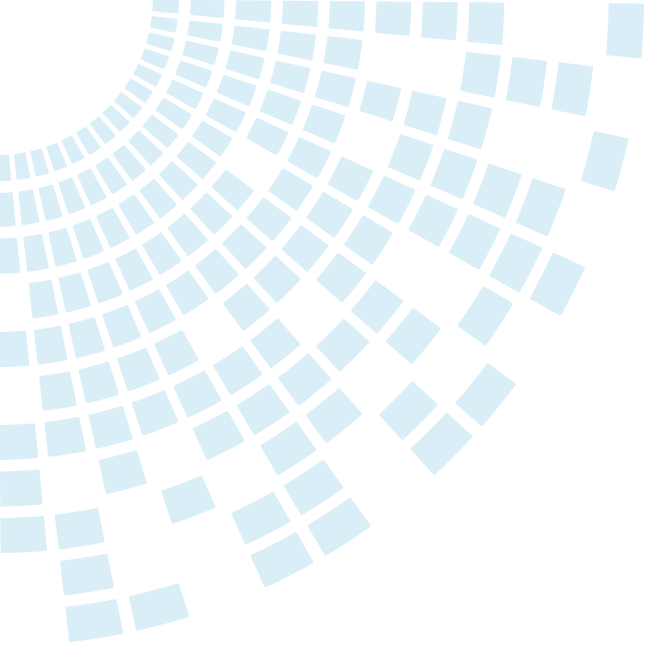

About Signal Transformer

Signal Transformer is known as the world's leader of wire wound magnetic solutions since 1959. With over 50 years of experience manufacturing transformers, chokes, inductors and custom or modified standard products. Signal offers not only the most comprehensive line of certified standard power conversion products, with our vast engineering, manufacturing and regulatory resources; Signal Transformer excels in the design and manufacturer of cost effective, specialized platforms.

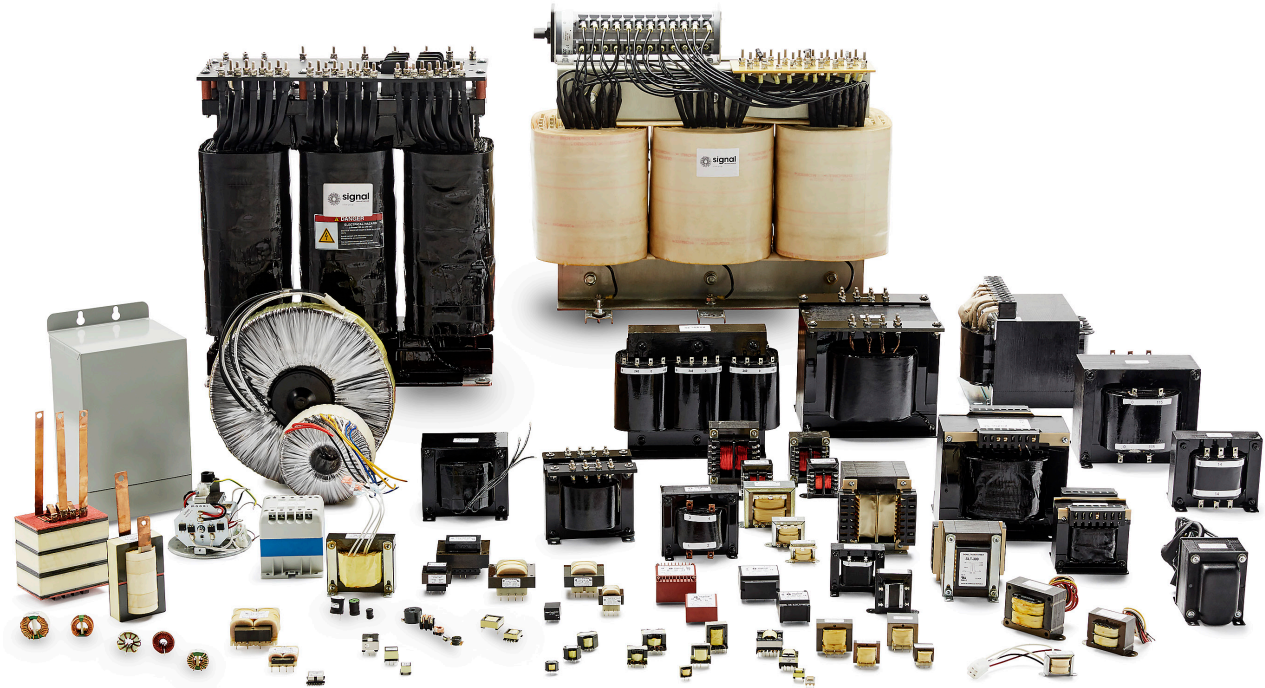

**For more information,
please contact us:**

128 Atlantic Avenue
Lynbrook, NY 11563

Toll Free +1 866-239-5777

Tel +1 516-239-5777

Fax +1 516-239-7208

sales@signaltransformer.com
techhelp@signaltransformer.com

belfuse.com/signal



Mouser Electronics

Authorized Distributor

Click to View Pricing, Inventory, Delivery & Lifecycle Information:

[Bel:](#)

[HCLC-680-2.7](#) [HCLC-12-14.2](#) [HCLC-180-4.7](#) [HCLC-470-3.7](#) [HCLC-560-3.5](#) [HCLC-150-4.9](#) [HCLC-15-13.6](#) [HCLC-220-4.4](#) [HCLC-56-9.8](#) [HCLC-82-7.1](#) [HCLC-820-2.5](#) [HCLC-10-14.3](#) [HCLC-330-4.0](#) [HCLC-390-3.8](#) [HCLC-270-4.2](#) [HCLC-47-10.3](#) [HCLC-1000-2.4](#) [HCLC-68-7.6](#) [HCLC-33-11.1](#) [HCLC-39-10.8](#) [HCLC-100-6.8](#) [HCLC-120-5.1](#) [HCLC-22-12.6](#) [HCLC-27-11.8](#) [HCLC-18-13.1](#)