

## SERIES 67C

### Hall Effect Joystick with Integrated Pushbutton & Optical Encoder

#### FEATURES

- Proportional joystick, pushbutton & optical encoder functions from a single shaft
- Analog joystick outputs are proportional to angle of shaft deflection
- Long life, high reliability
- Choices of cable length and termination
- Customized solutions available

#### APPLICATIONS

- Global positioning / Driver information systems
- Entertainment equipment
- Medical equipment controls
- Radio control belly boxes
- Robotics
- Aerospace
- Avionics
- Security camera controls



#### DIMENSIONS in inches

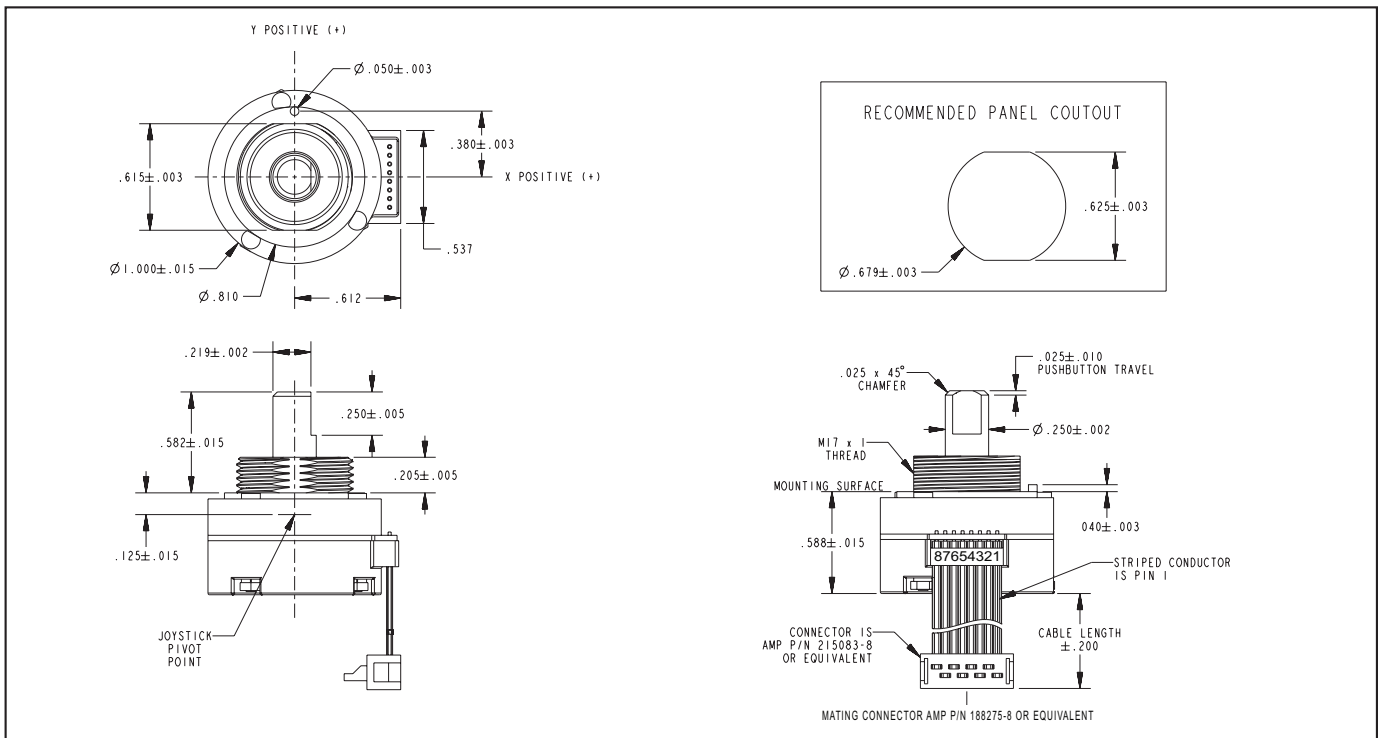

#### JOYSTICK OUTPUT WAVEFORM

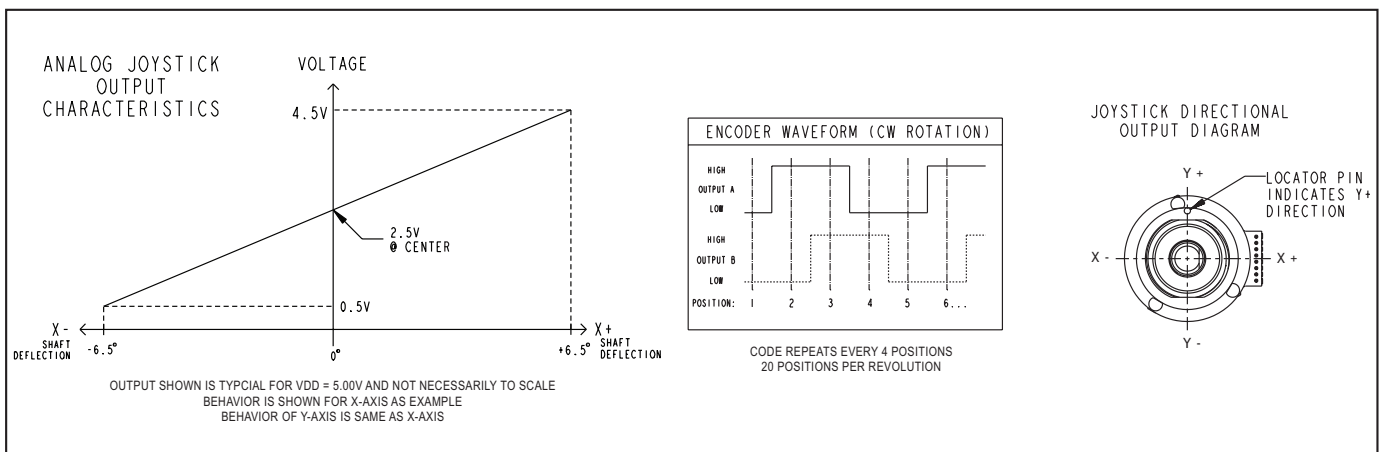

Joysticks



# Joysticks

## SPECIFICATIONS

### General Electrical Specifications

**Operating Voltage on Pin 6 (VDD):** 5.0 ± 0.25V

**Absolute Maximum Voltage\* on Pin 6 (VDD):** -0.3 V min, 6.5 V max.

**Operating Current:** 8 mA typ., 12 mA, max.

### Joystick Electrical and Mechanical Ratings

**Sensing Method:** Hall effect, proportional to angle of deflection

**Output Voltage (Pins 7 & 8):** Analog (Ratio-metric to Operating Voltage)

**Output at Center Position:** 50% VDD

**Output at Full Travel:**

10% VDD (for X-, Y- directions)

90% VDD (for X+, Y+ directions)

**Output Tolerance:** ± 2% VDD (at Center and at Full Travel)

**Output Current:** 200 µA, max.

**Angle of Throw:** 6.5° + 2° / -1° in main directions; 9.0° ± 0.1° in diagonals

**Life:** 500,000 actuations in each of the four main directions

### Pushbutton Electrical and Mechanical Ratings

**Rating:** 10 mA at 5 Vdc resistive

**Absolute Maximum Voltage\* on Pins 2 & 3:** 6.0 V

**Contact Resistance:** less than 10 ohms

**Life:** 1 million actuations minimum

**Contact Bounce:** < 4 mS make, < 10 mS break

**Actuation Force:** 960 ± 150 grams (700

grams Dome)

**Pushbutton Travel:** 0.025 ± 0.010 inches

### Rotary Electrical and Mechanical Ratings

**Output Code (Pins 4 & 5):** 2-Bit quadrature: Channel "A" leads channel "B" by 90° electrically during clockwise rotation of the shaft

**Output Type:** Push/Pull

**Output Low Voltage:** 0.6V maximum for IOL = 2 mA.

**Output High Voltage:** 4.3V minimum for IOH = -1.5 mA, (VDD = 5.0V)

**Mechanical Life:** 1 million rotational cycles of operation (1 cycle is a rotation through all positions and a full return)

**Mounting Torque:** 15 in-oz maximum

**Shaft Push-Out Force:** 45 lbs minimum

**Shaft Pull-Out Force:** 45 lbs minimum

**Solderability:** 95% free of pin holes and voids

**Detents:** 20 Position

**Torque:** Initially 3.5 ± 1.5 in-oz average of all positions, with a 1.5 in-oz maximum range (Max position - Min position) = Range

After 1 million cycles, average torque shall not change by more than 50% of the initial value

### Soldering Recommendation

Hand solder only per IPC J-STD-001

### Environmental Ratings

**Operating Temperature Range:** -40°C to 85°C

**Storage Temperature Range:** -55°C to

100°C

**Relative Humidity:** 96 hours at 90-95% humidity at 40°C

**Vibration:** Harmonic motion with amplitude of 15g, within a varied 10 to 2000 Hz frequency for 12 hours

**Mechanical Shock:**

Test 1: 100g for 6ms half-sine wave with a velocity change of 12.3 ft/s

Test 2: 100g for 6ms sawtooth wave with a velocity change of 9.7 ft/s

### Materials and Finishes

**Pin Header:** Terminals: Phosphor bronze; Insulator: Nylon 4/6; Plated with tin

**Cable:** Copper stranded with silver plating in PVC insulation, 28 AWG

**Connector:** Nylon 4/6; 30% Glass-filled; Tin-plated phosphor bronze terminals

**Mounting Nut:** Polyurethane

**Shaft:** Thermoplastic

**ROHS Compliant.**

### EMC Ratings

**Radiated Immunity:** Passed 10 V/m: 80-2700 MHz per IEC 61000-4-3

**Conducted Immunity:** Passed 10 V/m: 0.15 80 MHz per IEC 61000-4-6

**Radiated Emissions:** Passed EN 55022 Class B

**Conducted Emissions:** Passed EN 55022 Class B

**Electrostatic Discharge:** Passed 15kV contact/25kV air discharge per IEC 61000-4-2

**Power Frequency Magnetic Field:** Passed 30 A/m per IEC 61000-4-8

\* Exceeding the Absolute Maximum Voltage may result in permanent damage to the device. This is a stress rating only and functional operation of the device at those or any other conditions above those indicated in the operation listings of this specification is not implied.

Joysticks

## ORDERING INFORMATION

### CABLE LENGTH

020 = 2"

040 = 4"

060 = 6"

2" Increments

Leave blank if choosing pin header

Examples:

67C18-8-M-020 = 2.0" cable with connector

67C18-8-M-P = Pin header

**JOYSTICK DIRECTIONS**  
8 = 4 Sensors, 8 Directions  
(No Gating)

# 67CXX-X-X-XXXX

**FORCE OPTION**  
M = Medium Forces

### ROTATIONAL ENCODER RESOLUTION

18 = 18°, 20 positions

08 = Non-detent, 20 positions

00 = Non-turn

### TERMINATION

S = Stripped Cable

C = Cable with Connector

P = Pin Header

## BLOCK DIAGRAM

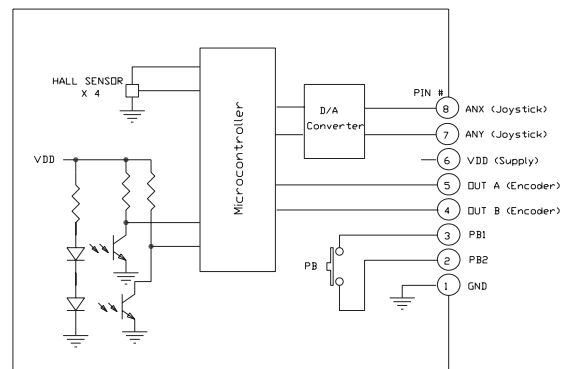

For prices and custom configurations, contact a local sales office, an authorized distributor, or Grayhill's sales department.

# Mouser Electronics

Authorized Distributor

Click to View Pricing, Inventory, Delivery & Lifecycle Information:

## Grayhill:

[67C18-8-M-P](#) [67C08-8-M-020C](#) [67C00-8-M-040C](#) [67C08-8-M-060S](#) [67C08-8-M-P](#) [67C08-8-M-040C](#) [67C00-8-M-060S](#) [67C00-8-M-P](#) [67C18-8-M-060S](#) [67C00-8-M-060C](#) [67C18-8-M-020C](#) [67C00-8-M-020S](#) [67C08-8-M-060C](#) [67C18-8-M-020S](#) [67C18-8-M-060C](#) [67C08-8-M-020S](#) [67C18-8-M-040C](#) [67C18-8-M-040S](#) [67C00-8-M-020C](#) [67C08-8-M-040S](#) [67C00-8-M-040S](#)