

P1153-822

15" TFT Intel® Pentium® M Expandable Industrial Panel Computer with 2 PCI Slots

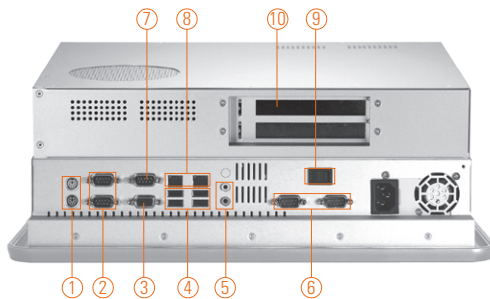

- | | |
|----------------------------|---------------------|
| 1. PS/2 K/B+M/S x 2 | 6. COM 5/6 (RS-232) |
| 2. COM 1/2 (RS-232) | 7. COM 3 (RS-232) |
| 3. VGA | 8. Ethernet x 2 |
| 4. USB 2.0 x 4 | 9. Power switch |
| 5. Audio (Mic-in/Line-out) | 10. PCI x 2 |

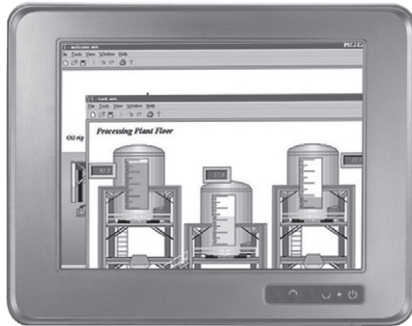

DualView

Introduction

The P1153-822 is a 15" Industrial panel PC which features Intel® Pentium® M processor and Intel® 910GMLC chipset to provide powerful computing performance. This panel PC also offers the expansion ability with 2 PCI slots. Further, the P1153-822 adopts built-in speaker and WLAN module for wireless connectivity.

Powerful computing: Intel® Pentium® M processor

The P1153-822 features Intel® Pentium® M with a maximum of FSB 1066MHz and Intel® 910GMLC+ICH6M chipset. It features two IEEE 1394a ports, two gigabit Ethernet ports and up to 3GB of dual-channel DDR2 system memory which deliver high computing capability for high performance-demanding applications.

Expandable for 2 PCI slots

The P1153-822 has 2 PCI slots for expansion purpose. User can easily plug in standard half-size PCI cards such as motion card, communication card and so on.

Speaker & WLAN Antenna Supported

The P1153-822 features built-in speaker, optional WLAN module and antenna for wireless network connectivity.

Features

- 15" XGA TFT LCD display
- Industrial-grade material front bezel: anti-corrosion
- Supports 2 PCI slots
- Supports panel mount and rack mount
- Supports dimming control

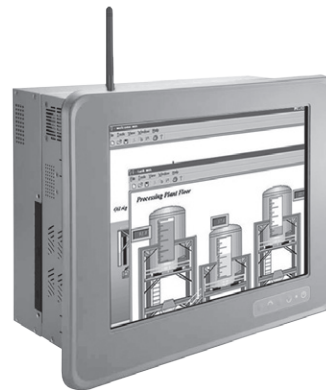

▲ Side view

Specifications

Front Bezel	IP65, NEMA 4 rugged protection, Industrial-grade material front bezel	
LCD Panel	Display Type	15" XGA TFT LCD
	Brightness (cd/m ²)	250 nits
	Resolution	1024 x 768 pixels
	Viewing Angle (H/V)	140°/120°
Main System	CPU	Socket 478 for Intel® Pentium® M/ Celeron® M processor with FSB 400 MHz
	Chipset	Intel® 910GMLC + ICH6M
	System Memory	2 x 240-pin DDR2 DIMM max. up to 2 GB
	BIOS	Award 4Mbit with RPL/PEX LAN boot ROM, Smartview and customer CMOS backup
	Storage	2 x 3.5" or 2 x 2.5" SATA HDD
	Watchdog Timer	255 levels, 1~255 sec.

Specifications

I/O Connector	5 x RS-232 (COM 1-5) 4 x USB 2.0 2 x PS/2 keyboard/mouse 2 x 10/100/1000Mbps Ethernet 1 x Audio (Mic-in/Line-out) 1 x D-sub 15-pin (female) for VGA output
Touchscreen	5-wire resistive type Light Transmission 79% 1 million activations (typical) at a single point
Power Supply	100 ~ 240VAC, 250W
Dimensions	420 mm (16.54") (W) x 150 mm (5.9") (D) x 335 mm (13.2") (H)
Packing Dimensions	610 mm (24.02") (W) x 260 mm (10.24") (D) x 590 mm (23.23") (H)
Weight (net/gross)	6.56 kg (14.5 lb)/10 kg (20.0 lb)
Environment	Operating temperature: 0° ~ +40°C (+32°F ~ +104°F) Storage Temperature: -20°C ~ +65°C (-4°F ~ +149°F) Relative humidity: 10% ~ 95% @ 40°C, non-condensing Operation vibration: 1.0 G, 5-500Hz, random
Certification	CE

Ordering Information

P1153-822	15" XGA TFT socket 478 Intel® Pentium® M expandable industrial panel PC with 2 PCI slots
-----------	--

* Specification and certifications are based on options and may vary.

Optional Accessories

82211530050E	3.5" HDD kit
82211580080E	2.5" HDD kit
82211530110E	Wireless LAN kit
82261580070E	Rack mounting kit

Optional OS Installation

Windows® XP/Vista

Overview

Industrial Panel Computers & Monitors

Heavy-duty Fanless Touch Panel Computers

Digital Signage Solutions

Healthcare & Medical Solutions

Open Frame Panel Computers

Accessories

Dimensions

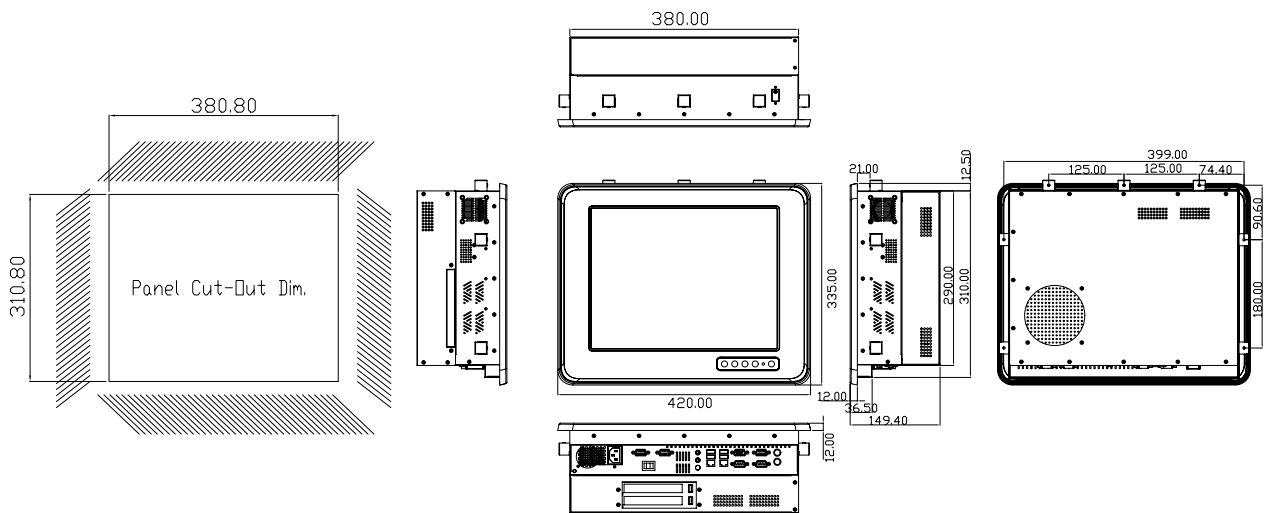

Mouser Electronics

Authorized Distributor

Click to View Pricing, Inventory, Delivery & Lifecycle Information:

[Axiomtek:](#)

[P1153-822](#)