

## Evaluates: MAX96751

## MAX96751 Evaluation Kit

### General Description

The MAX96751 evaluation kit (EV Kit) provides a proven design to evaluate the MAX96751 high-bandwidth gigabit multimedia serial-link (GMSL) serializer with spread spectrum and full-duplex control channel with the use of a standard FAKRA coaxial cable. The EV kit also includes Windows® 10 software to provide a simple graphical user interface (GUI) for exercising features of the device.

For complete GMSL evaluation, order the MAX96751 coax EV kit and a companion deserializer board (MAX96752 coax EV kit referenced in this document).

**Note:** In the following sections, serializer refers to MAX96751. Deserializer refers to MAX96752.

**Note:** This document applies to both coax and HSD-STQ evaluation kits, coax EV kit is referenced in this document.

### Benefits and Features

- HDMI 2.0 Serializer EV Kit to Drive GMSL-2 Serial Data Outputs (50Ω FAKRA Coax or 100Ω HSD-STQ Connectors)
- 3Gbps or 6Gbps Forward Link Rates for System and Power Flexibility
- Configurable Power-Over-Coax (PoC) and Line Fault Circuits
- I2S Audio Interface
- Header for GPIO, I2C, UART and SPI Signals
- Windows 10-Compatible Software
- Tools to Characterize GMSL Channel Signal Integrity
- 12V DC Supply (Included), USB, PoC or Externally Powered
- Proven PCB Layout
- Fully Assembled and Tested

### MAX96751 EV Kit Files

FILE	DESCRIPTION
GMSL SerDes Public GUI_VX_X_X_X_Install.exe	Installs the evaluation kit files in your computer
GMSL-SerDesEV.exe	Graphical user interface (GUI) program

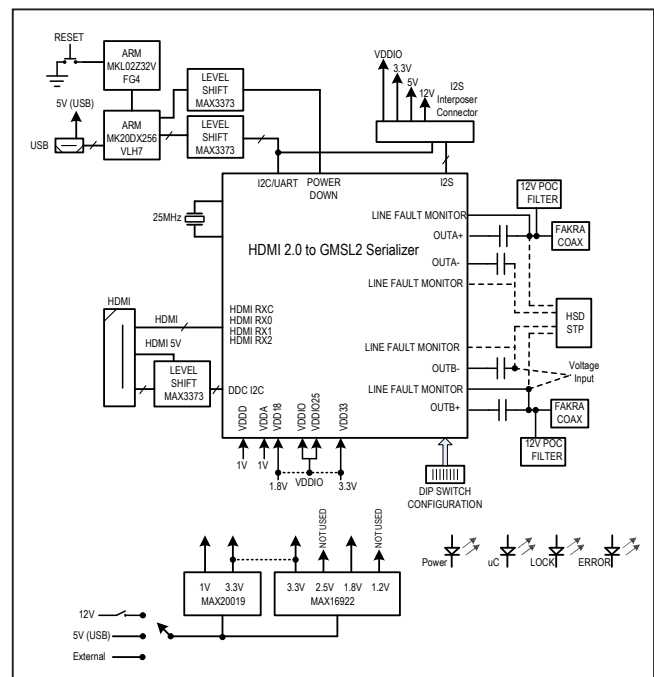

Figure 1. Serializer Evaluation Board Block Diagram

[Ordering Information](#) appears at end of data sheet.

**Quick Start**

**Required Equipment**

To get started evaluating there are a few installation and setup requirements. This procedure walks you through the necessary steps for basic bring-up of the deserializer EV kit. [Figure 2](#) shows a typical application using an HDMI Serializer with the oLDI deserializer.

**Note:** In the following sections, software-related items are identified by bolding. Text in **bold** refers to items from the EV Kit software. Text in **bold and underlined** refers to items from the Windows operating system.

**Required Equipment**

- MAX96751 coax EV kit
- MAX96752 coax EV kit
- FAKRA Coax Cable
- HDMI source, such as laptop computer or HDMI signal generator
- oLDI Display and oLDI Adapter Board
- Windows 10 PC with a spare USB port
- 12V DC, 500mA power supply

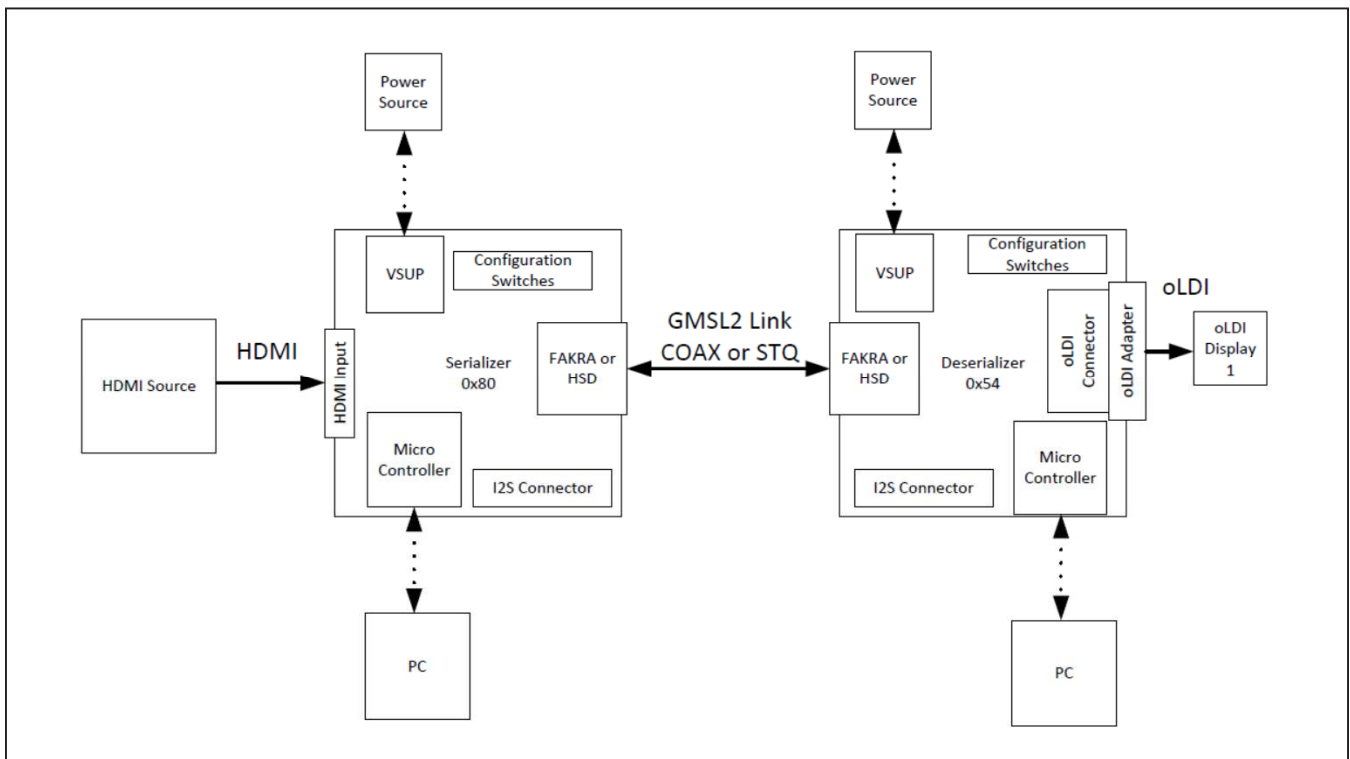

Figure 2. Typical GMSL System Evaluation Setup Block Diagram

**Procedure**

The MAX96751 COAX/STQ EV kit is shipped with the PCB fully assembled and tested. Follow the steps below to verify board operation:

- 1) Download and install latest GMSL2 EV kit software from the MAX96751 Evaluation Kit product page.
- 2) Verify that the on-board jumpers on the deserializer board are in their default positions (Figure 3) with SW1 off.
- 3) Configure SW3 as shown in Figure 3 to set serializer address to 0x80, coax mode, and I<sup>2</sup>C control.
- 4) Connect the FAKRA cable from the OUTA+ terminal on the serializer board to the INA+ terminal on the deserializer.
- 5) Connect the +12V wall DC power supply into J1. See Figure 4 for power supply details.
- 6) Turn SW1 on for both the serializer and deserializer EV kits.
- 7) Verify that the blue power LED and red Teensy® LED are illuminated.
- 8) Verify the lock LED on both serializer and deserializer EV kits light up, indicating that the link has been

- 9) Connect the USB cable between the PC and J4 on the serializer EV kit. Start the GUI by selecting Start | Programs | Analog Devices Inc | GMSL-SerDesEV.
- 10) When the GUI opens, it automatically searches for any active listener in both I<sup>2</sup>C and UART mode and identifies a valid GMSL product. Once the serializer and deserializer are identified, they are shown as tabs in the GUI.
- 11) Read register 0x00 in both deserializer and serializer to ensure both devices are active.
- 12) Basic bring-up is now complete. Refer to Help | User's Manual for GUI operation, GMSL2 User's Guide for configuration of this device and its available features, or ADI Applications for additional details and support.

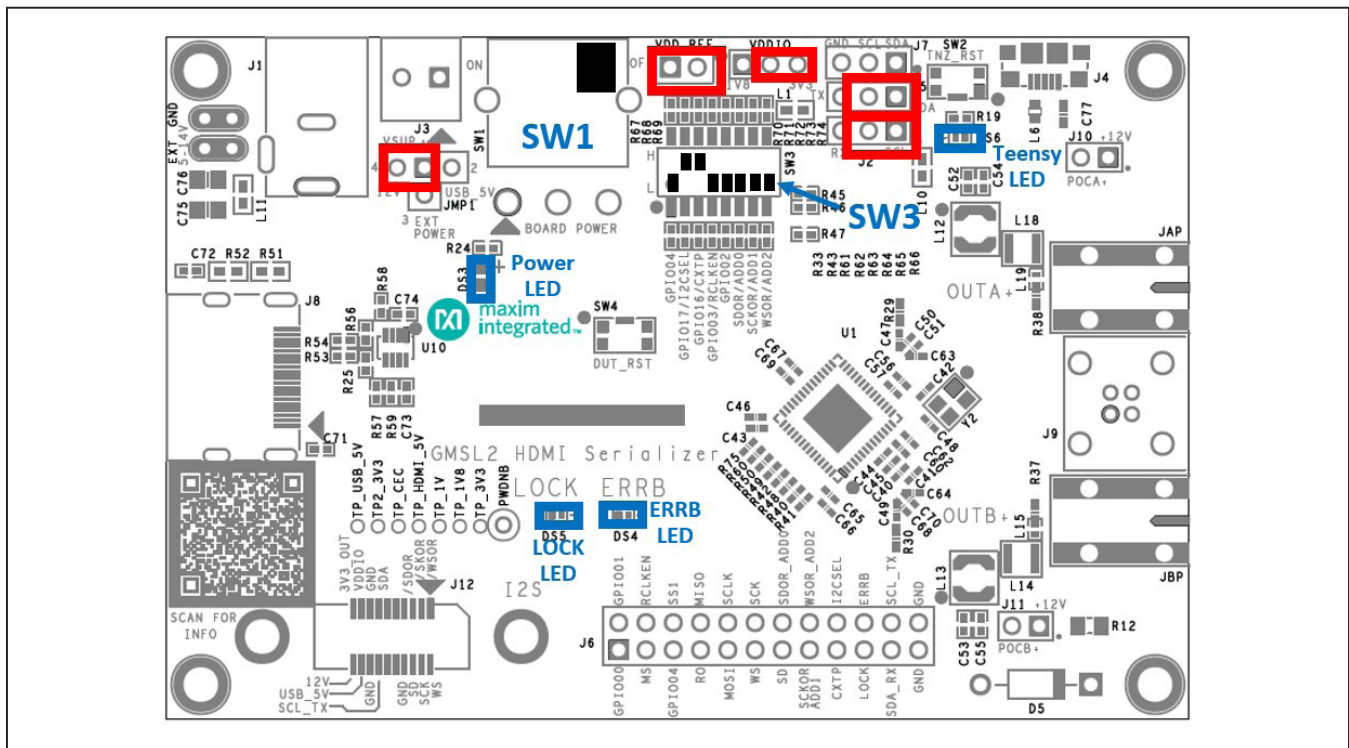

Figure 3. Serializer Evaluation Board Default Jumper

TEENSY is a registered trademark of PJRC.COM LLC.

Table 1. Jumper Description

JUMPER	SIGNAL	DEFAULT POSITION	FUNCTION
JMP1	VSUP	12V	Select source of board power
VDDIO	VDDIO	3.3V	Select between 1.8V and 3.3V
J2	SCL_TX	SCL	I <sup>2</sup> C or UART connection to serializer
J5	SDA_RX	SDA	I <sup>2</sup> C or UART connection to serializer
J10	POCA	Open	Power-over-coax enable for PHY A
J11	POCB	Open	Power-over-coax enable for PHY B
C63/C51	SIOA+	C63 (FAKRA/COAX)	Allows switching between FAKRA and HSD connector
C64/C70	SIOB+	C64 (FAKRA/COAX)	Allows switching between FAKRA and HSD connector
C47/C50	SIOA-	C47 (AC Term)	Allows switching between AC termination and HSD connector
C49/C68	SIOB-	C49 (AC Term)	Allows switching between AC termination and HSD connector
J6	GPIO00	N/A	Test Point
J6	MS	N/A	Test Point
J6	GPIO04	N/A	Test Point
J6	RO	N/A	Test Point
J6	MOSI	N/A	Test Point
J6	WS	N/A	Test Point
J6	SD	N/A	Test Point
J6	SCKOR_ADD1	N/A	Test Point
J6	CXTP	N/A	Test Point
J6	LOCK	N/A	Test Point
J6	SDA_RX	N/A	Test Point
J6	GND	N/A	Test Point
J6	GPIO01	N/A	Test Point
J6	RCLKEN	N/A	Test Point
J6	SS1	N/A	Test Point
J6	MISO	N/A	Test Point
J6	SCLK	N/A	Test Point
J6	SCK	N/A	Test Point
J6	SDOR_ADD0	N/A	Test Point
J6	WSOR_ADD2	N/A	Test Point
J6	I2CSEL	N/A	Test Point
J6	ERRB	N/A	Test Point
J6	SCL_TX	N/A	Test Point
J6	GND	N/A	Test Point



**Table 1. Jumper Description (continued)**

<b>JUMPER</b>	<b>SIGNAL</b>	<b>DEFAULT POSITION</b>	<b>FUNCTION</b>
TP_USB_5V	USB 5V	N/A	Test Point
TPS_3V3	3.3V	N/A	Test Point
TP_CEC	CEC (HDMI)	N/A	Test Point
TP_HDMI_5V	HDMI 5V	N/A	Test Point
TP_1V	1V	N/A	Test Point
TP_1V8	1.8V	N/A	Test Point
TP_3V3	3.3V	N/A	Test Point
PWDNB	Power Down (active low)	N/A	Test Point

**Table 2. Items Included in the Evaluation Kit Package**

<b>ITEM DESCRIPTION</b>	<b>QTY</b>
MAX96751 EV Kit	1
USB Cable	1
+12V Wall Supply	1

## Troubleshooting

If the MAX96751 EV Kit fails to power-up or does not function properly, try the appropriate remedial actions below:

- 1) Make sure the boards' red power switches (SW1) are set to the ON position.
- 2) Verify that the device is powered properly. Check to ensure that the voltages at all device pins are within their operating ranges.
- 3) Check that all jumpers are correctly set. Refer to the default jumper settings table in the serializer and deserializer EV kit data sheets. Also ensure that all jumpers are firmly attached. Replace loose or damaged jumpers if necessary.
- 4) Check that the USB cable is properly seated in the USB port. The USB LED should be lit if connected to a PC, even if the board is powered down.
- 5) Check that the serializer and deserializer GMSL generations match. Both devices should start in the same mode (GMSL2).
- 6) Check that the COAX/STQ cable connection between serializer and deserializer is good—it clicks when plugged in fully.
- 7) Check to see if the DUT has been inadvertently put into Teensy reset mode. The board's TEENSY\_RST button should only be pressed when firmware is being flashed to the DUT. If the button is pressed during normal operation, the device goes into Teensy reset mode. Power-cycle the board to resume normal operation with the current firmware.
- 8) Check that the I<sup>2</sup>C/UART jumpers match the DUT communication mode (SCL/SDA for I<sup>2</sup>C, TX/RX for UART).
- 9) Check that the AC coupling capacitors are populated correctly and routing the serial link to the correct connector for COAX or STQ mode. For coax boards, capacitors C63 and C46 (SIOA) and capacitors C64 and C49 (SIOB) should be populated. For HSD boards, capacitors C60 and C51 (SIOA), and capacitors C68 and C70 (SIOB) should be populated. (MAX96751 COAX/HSD EV kit boards are shipped with the correct capacitors installed.)
- 10) Check if the LOCK LED is ON in the absence of a connection to the deserializer: If so, then the DUT is either not powered correctly or damaged.
- 11) Check that the microcontroller firmware is active by observing the blinking red Teensy LED (DS6) at power-up. If the LED is not blinking, refer to the available software documentation to reprogram the microcontroller.
- 12) Check that the PC is detecting the COM port when the micro-USB cable is connected. Use the Windows Device Manager to check COM port status.
- 13) Power-cycle the board and reopen the GUI.
- 14) Serializer board is faulty, try a new or different serializer board.

Detailed Description of Hardware

The power configuration of the EV kit hardware may be re-configured to allow external supply connections. [Figure 4](#) shows the power connection options.

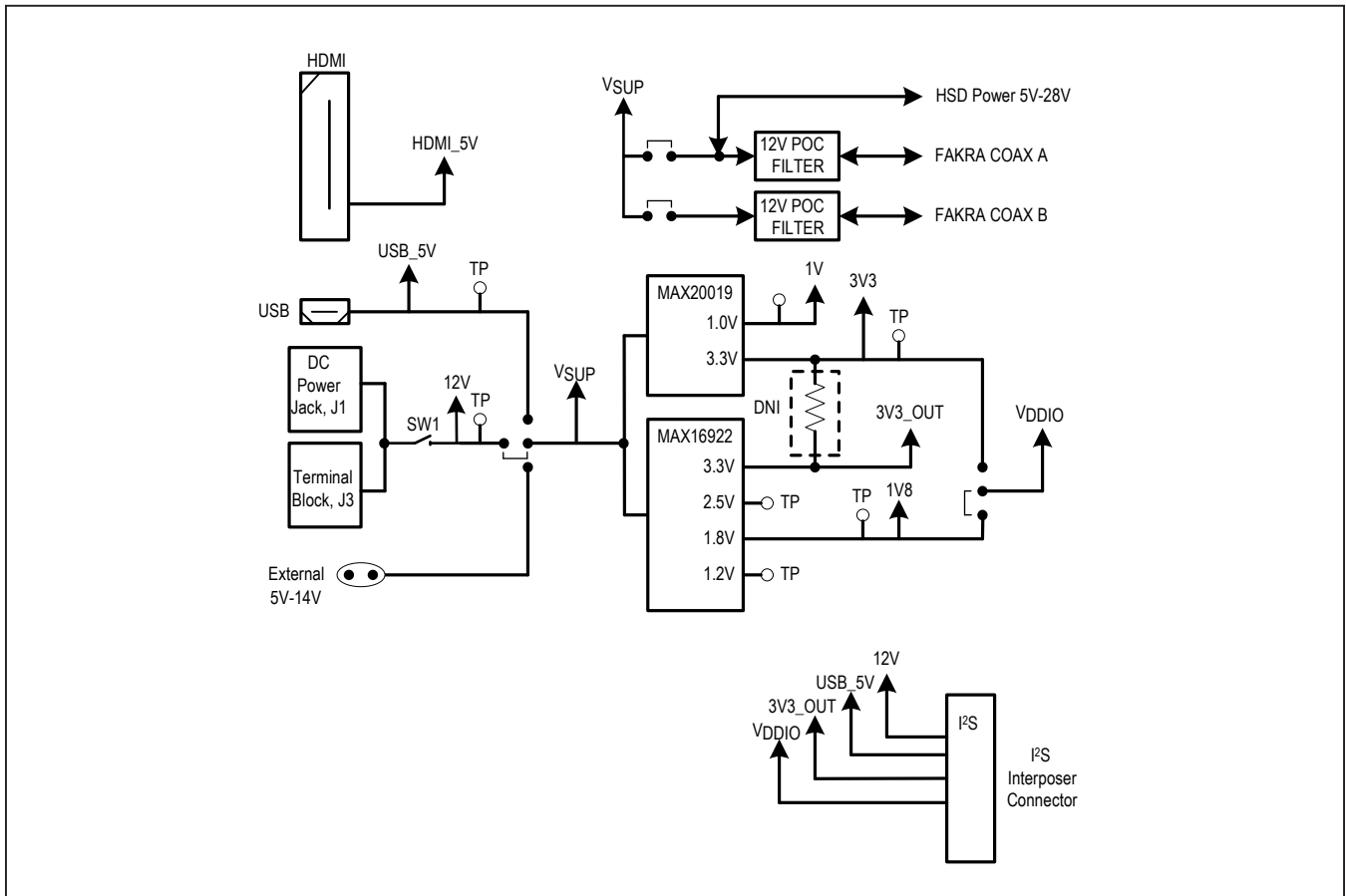

Figure 4. Serializer Evaluation Board Power Connection Diagram

## Component Suppliers

SUPPLIER	PHONE	WEBSITE
Amphenol RF	800-627-7100	www.amphenolrf.com
Hong Kong X'tals Ltd.	852-35112388	www.hongkongcrystal.com
Murata Electronics North America, Inc.	770-436-1300	www.murata-northamerica.com
ON Semiconductor	602-244-6600	www.onsemi.com
Rosenberger Hochfrequenztechnik GmbH	011-49-86 84-18-0	www.rosenberger.de
TDK Corp.	847-803-6100	www.component.tdk.com

**Note:** Indicate that you are using the MAX96751 when contacting these component suppliers.

## Ordering Information

PART	TYPE
MAX96751COAXEVKIT#	EV kit
MAX96751HSDEVKIT#	EV kit
MAX-GMSL-I2S-ADP#	I <sup>2</sup> S Audio Adapter

#Defines RoHs Compliant

**Note:** The MAX96751 coax EV kits are normally ordered with a companion deserializer board:  
- MAX96752 EV kit (MAX96752COAXEVKIT#)

MAX96751EV Kit Bill of Materials

ITEM	REF_DES	DNI/DNP	QTY	MFG PART #	MANUFACTURER	VALUE	DESCRIPTION	COMMENTS
1	C1, C2	-	2	EMK316BB7226ML	TAIYO YUDEN	22UF	CAPACITOR; SMT (1206); CERAMIC CHIP; 22UF; 16V; TOL=20%; TG=-55 DEGC TO +125 DEGC; TC=X7R	
2	C6, C7	-	2	C3216X5R1E476M160AC	TDK	47UF	CAPACITOR; SMT (1206); CERAMIC CHIP; 47UF; 25V; TOL=20%; MODEL=C SERIES; TG=-55 DEGC TO +85 DEGC; TC=X5R ;	
3	C8, C9, C12-C14, C19-C25, C77	-	13	GRT188R61C106KE13	MURATA	10UF	CAPACITOR; SMT (0603); CERAMIC CHIP; 10UF; 16V; TOL=10%; TG=-55 DEGC TO +85 DEGC; TC=X5R; AUTO	
4	C10, C11, C17, C18, C26, C29-C32, C34-C41, C46, C47, C49, C52, C53, C56, C58, C59, C62-C64, C66, C67, C72-C74, C78	-	34	CGA2B3X7R1H104K050BB;C1005X7R1H104K050BB;GRM155R71H104KE14;GCM155R71H104KE02;C1005X7R1H104K050BE;UMK105B7104K V-FR;CGA2B3X7R1H104K050BE	TDK;TDK;MURATA;MURATA;TDK;TAIYO YUDEN;TDK	0.1UF	CAPACITOR; SMT (0402); CERAMIC CHIP; 0.1UF; 50V; TOL=10%; TG=-55 DEGC TO +125 DEGC; TC=X7R	
5	C15	-	1	C1608X7R1V105K080AC;CGA3E1X7R1V105K080AC	TDK;TDK	1UF	CAPACITOR; SMT (0603); CERAMIC CHIP; 1UF; 35V; TOL=10%; TG=-55 DEGC TO +125 DEGC; TC=X7R	
6	C16, C28, C33	-	3	GRM188Z71C225KE43	MURATA	2.2UF	CAPACITOR; SMT (0603); CERAMIC CHIP; 2.2UF; 16V; TOL=10%; TG=-55 DEGC TO +125 DEGC; TC=X7R	
7	C42, C48	-	2	C0402C0G500-150JNP; GRM1555C1H150JA01	VENKEL LTD.;MURATA	15PF	CAPACITOR; SMT (0402); CERAMIC CHIP; 15PF; 50V; TOL=5%; TG=-55 DEGC TO +125 DEGC; TC=C0G	
8	C43-C45, C54, C55, C57, C60, C61, C65, C69	-	10	GRM155R71H103JA88	MURATA	0.01UF	CAPACITOR; SMT (0402); CERAMIC CHIP; 0.01UF; 50V; TOL=5%; TG=-55 DEGC TO +125 DEGC; TC=X7R	
9	C71	-	1	C0402C0G500-470JNE;CC0402JRNPO9B470;GRM1555C1H470JA01;CL05C470JB5N NN	VENKEL LTD.;YAGEO PHYCOMP;MURATA;SAMSUNG ELECTRONICS	47PF	CAPACITOR; SMT (0402); CERAMIC CHIP; 47PF; 50V; TOL=5%; MODEL=; TG=-55 DEGC TO +125 DEGC; TC=C0G	
10	C75, C76	-	2	TMK212AB7475K;CGJ4J1X7R1E475K125AC;C2012X7R1E475K125AB;CGA4J1X7R1E475K125AC;GRM21BZ71E475KE15	TAIYO YUDEN;TDK;TDK;MURATA	4.7UF	CAPACITOR; SMT (0805); CERAMIC CHIP; 4.7UF; 25V; TOL=10%; TG=-55 DEGC TO +125 DEGC; TC=X7R	
11	D1, D2	-	2	ES1D	FAIRCHILD SEMICONDUCTOR	ES1D	DIODE; RECT; SMA (DO-214AC); PIV=200V; IF=1A	
12	D3	-	1	DFLS140L	DIODES INCORPORATED	DFLS140L	DIODE; SCH; SMT (POWERDI-123); PIV=40V; IF=1A	
13	D4	-	1	B360B-13-F	DIODES INCORPORATED	B360B-13-F	DIODE; SCH; SCHOTTKY BARRIER DIODE; SMB; PIV=60V; I0=3A; -55 DEGC TO +125 DEGC	
14	D5	-	1	1N4742A	FAIRCHILD SEMICONDUCTOR	12V	DIODE, ZENER, DO-41, Pd=1W, Vz=12V@Iz=21mA	
15	DS3	-	1	SML13BC8T	ROHM SEMICONDUCTOR	SML13BC8T	DIODE; LED; SML-E1 SERIES; BLUE; SMT (0603); VF=2.9V; IF=0.005A	
16	DS4, DS6	-	2	SML-P11UTT86	ROHM	SML-P11UTT86	DIODE; LED; SMT; PIV=1.8V; IF=0.02A	
17	DS5	-	1	SML-P11MTT86	ROHM	SML-P11MTT86	DIODE; LED; SMT; PIV=5V; IF=0.02A	
18	EXT, GND	-	2	9020 BUSS	WEICO WIRE	MAXIMPAD	EVK KIT PARTS: MAXIM PAD; WIRE; NATURAL; SOLID; WEICO WIRE; SOFT DRAWN BUS TYPE-S; 20AWG	
19	J1	-	1	PJ-002AH	CUI INC.	PJ-002AH	CONNECTOR; MALE; THROUGH HOLE; DC POWER JACK; RIGHT ANGLE; 3PINS	
20	J2, J5, VDDIO	-	3	PCC03SAAN	SULLINS	PCC03SAAN	CONNECTOR; MALE; THROUGH HOLE; BREAKAWAY; STRAIGHT THROUGH; 3PINS; -65 DEGC TO +125 DEGC	
21	J3	-	1	393570002	MOLEX	393570002	CONNECTOR; FEMALE; THROUGH HOLE; 0.3MM PITCH BEAU EUROSTYLE FIXED MOUNT PCB TERMINAL BLOCK; RIGHT ANGLE; 2PINS	
22	J4	-	1	1981568-1	TE CONNECTIVITY	1981568-1	CONNECTOR; FEMALE; SMT; MICRO USB STANDARD TYPE B ASSY; RIGHT ANGLE; 5PINS	
23	J6	-	1	PEC12DAAN	SULLINS ELECTRONICS CORP	PEC12DAAN	CONNECTOR; MALE; THROUGH HOLE; .1IN CC; BREAKAWAY HEADER; STRAIGHT; 24PINS	
24	J7	-	1	PBC03SAAN	SULLINS	PBC03SAAN	CONNECTOR; MALE; THROUGH HOLE; BREAKAWAY; STRAIGHT; 3PINS; -65 DEGC TO +125 DEGC	
25	J8	-	1	HDNR-19-01-S-SM	SAMTEC	HDNR-19-01-S-SM	CONNECTOR; FEMALE; SMT; HIGH SPEED IO RECEPTACLE; RIGHT ANGLE; 19PINS	
26	J10, J11	-	2	PCC02SAAN	SULLINS	PCC02SAAN	CONNECTOR; MALE; THROUGH HOLE; BREAKAWAY; STRAIGHT THROUGH; 2PINS; -65 DEGC TO +125 DEGC	
27	J12	-	1	ERF8-010-05.0-S-DV-K	SAMTEC	ERF8-010-05.0-S-DV-K	CONNECTOR; FEMALE; SMT; RUGGED HIGH SPEED SOCKET; STRAIGHT; 20PINS;	
28	JAP, JBP	-	2	59S2AQ-40MTS-Z_1	ROSENBERGER	59S2AQ-40MTS-Z_1	CONNECTOR; MALE; THROUGH HOLE; FAKRA-HF RIGHT ANGLE PLUG PCB WITH HOUSING; RIGHT ANGLE; 5PINS	
29	JMP1	-	1	PEC04SAAN	SULLINS ELECTRONICS CORP.	PEC04SAAN	CONNECTOR; MALE; THROUGH HOLE; BREAKAWAY; STRAIGHT; 4PINS	
30	L1, L6, L8-L10	-	5	BLM18KG601SN1	MURATA	600	INDUCTOR; SMT (0603); FERRITE-BEAD; 600; TOL=+-25%; 1.3A	
31	L2	-	1	DPE252012P-4R7M=P2	MURATA	4.7UH	INDUCTOR; SMT (2520); FERRITE CORE; 4.7UH; TOL=+-20%; 1.7A	
32	L3, L4	-	2	TFM201610ALMA2R2MTAA	TDK	2.2UH	INDUCTOR; SMT (2016); THIN FILM; 2.2UH; TOL=+-20%; 2.1A	
33	L5	-	1	TFM252012ALMA-3R3MTAA	TDK	3.3UH	EVKIT PART-INDUCTOR; SMT; ORIGINAL FINE COPPER; 3.3UH; TOL=+-20%; 2.2A	
34	L7	-	1	RFCMF1220100M3	WALSIN TECHNOLOGY CORPORATION	RFCMF1220100M3	INDUCTOR; SMT; CERAMIC CHIP; CHOKE; 0.3A	
35	L11	-	1	BLM18SG121TN1	MURATA	120	INDUCTOR; SMT (0603); FERRITE-BEAD; 120; TOL=+-25%; 3A	
36	L12, L13	-	2	LPS4040-154MR	COILCRAFT	150UH	INDUCTOR; SMT; FERRITE; 150UH; 20%; 0.65A ;	
37	L14, L18	-	2	1210POC-223MR	COILCRAFT	22UH	INDUCTOR; SMT; FERRITE; 22UH; 20%; 0.7A ;	
38	L15, L19	-	2	PFL1005-561MR	COILCRAFT	560NH	INDUCTOR; SMT (0402); SHIELDED; 560NH; 20%; 0.53A	
39	PWDNB	-	1	5000	KEYSTONE	N/A	TEST POINT; PIN DIA=0.1IN; TOTAL LENGTH=0.3IN; BOARD HOLE=0.04IN; RED; PHOSPHOR BRONZE WIRE SILVER PLATE FINISH;	
40	R1-R3, R20-R23, R25, R26, R33, R43, R55-R59, R61-R66, R80, R81	-	24	ERJ-2GEJ103	PANASONIC	10K	RESISTOR; 0402; 10K OHM; 5%; 200PPM; 0.10W; THICK FILM	

MAX96751EV Kit Bill of Materials (continued)

ITEM	REF_DES	DNI/DNP	QTY	MFG PART #	MANUFACTURER	VALUE	DESCRIPTION	COMMENTS
41	R4, R5	-	2	ERJ-2GEJ203	PANASONIC	20K	RESISTOR; 0402; 20K OHM; 5%; 200PPM; 0.10W; THICK FILM	
42	R6-R11, R18	-	7	CRCW06030000ZS;MCR03EZPJ000;ERJ-3GEY0R00	VISHAY DALE;ROHM;PANASONIC		0 RESISTOR; 0603; 0 OHM; 0%; JUMPER; 0.10W; THICK FILM	
43	R12	-	1	1676429; RN73C2A768RB	TE CONNECTIVITY;TE CONNECTIVITY	768	RESISTOR; 0805; 768 OHM; 0.1%; 10PPM; 0.1W; THIN FILM	
44	R13, R40-R42, R45-R50, R60, R75	-	12	ERJ-2GE0R00	PANASONIC		0 RESISTOR; 0402; 0 OHM; 0%; JUMPER; 0.10W; THICK FILM	
45	R15, R16	-	2	CRCW040233R0FK	VISHAY DALE	33	RESISTOR; 0402; 33 OHM; 1%; 100PPM; 0.0625W; THICK FILM	
46	R17	-	1	ERJ-2RKF4700	PANASONIC	470	RESISTOR; 0402; 470 OHM; 1%; 100PPM; 0.1W; THICK FILM	
47	R19, R31, R32, R67-R74	-	11	ERJ-2RKF1001	PANASONIC	1K	RESISTOR; 0402; 1K OHM; 1%; 100PPM; 0.10W; THICK FILM	
48	R24	-	1	ERJ-2RKF2000	PANASONIC	200	RESISTOR; 0402; 200 OHM; 1%; 100PPM; 0.10W; THICK FILM	
49	R27, R28	-	2	CRCW040222K20JN	VISHAY DALE	2.2K	RESISTOR; 0402; 2.2K OHM; 5%; 200PPM; 0.063W; METAL FILM	
50	R29, R30	-	2	CRCW060349R9FK	VISHAY DALE	49.9	RESISTOR; 0603; 49.9 OHM; 1%; 100PPM; 0.10W; THICK FILM	
51	R35	-	1	CRCW0603402RFK	VISHAY DALE	402	RESISTOR; 0603; 402 OHM; 1%; 100PPM; 0.10W; THICK FILM	
52	R51, R52	-	2	CRCW0603100KFK;RC0603FR-07100KL;RC0603FR-13100KL;ERJ-3EKF1003;AC0603FR-07100KL	VISHAY DALE;YAGEO;YAGEO;PANASONIC	100K	RESISTOR; 0603; 100K; 1%; 100PPM; 0.10W; THICK FILM	
53	R53, R54	-	2	ERJ-2GEJ220	PANASONIC	22	RESISTOR; 0402; 22 OHM; 5%; 200PPM; 0.10W; METAL FILM	
54	SW1	-	1	1101-M2-S3-A-Q-E-2	C&K COMPONENTS	1101-M2-S3-A-Q-E-2	SWITCH; SPDT; THROUGH HOLE; RIGHT ANGLE; 120V; 6A; 1000 SERIES; RCOIL=0.1 OHM; RINSULATION=100G OHM	
55	SW2, SW4	-	2	KMR421G LFS	C&K COMPONENTS	KMR421G LFS	SWITCH; SPST; SMT; STRAIGHT; 32V; 0.05A; MICROMINIATURE SMT TOP ACTUATED; RCOIL=0.1 OHM OHM; RINSULATION=1G OHM OHM	
56	SW3	-	1	97C08S	GRAYHILL	97C08S	SWITCH;SPST;SMT;RINSULATIONS=100MOHM;GRAYHILL	
57	U1	-	1	MAX96751GTN/V+	ANALOG DEVICES	MAX96751GTN/V+	EVKIT PART - IC; MAX96751; GMSL2 HDMI 2.0 INPUT; PACKAGE OUTLINE DRAWING: 21-0135; PACKAGE LAND PATTERN: 90-100041; PACKAGE CODE: T5688+6	
58	U2	-	1	MAX20019ATBI/V+	ANALOG DEVICES	MAX20019ATBI/V+	EVKIT PART-IC; VCON; 3.2MHZ; 500MILLIAMPERE DUAL STEP-DOWN CONVERTER FOR AUTOMOTIVE CAMERA; PACKAGE OUTLINE: 21-100125; LAND PATTERN DRAWING NO.: 90-100079; PACKAGE CODE: T1032+2C; TDFN10-EP	
59	U3	-	1	MK20DX256VLH7	FREESCALE	MK20DX256VLH7	IC; UCON; KINETIS K2X MCU FAMILY; LQFP64	
60	U4	-	1	IC_MKL02Z32_QFN16	PJRC	IC_MKL02Z32_QFN16	IC; UCON; KINETIS KL02 32 KB FLASH; 48 MHZ CORTEX-M0+ BASED MICROCONTROLLER; MKL02 CHIP WITH PRE-PROGRAMMED TEENSY LC AND 3.2 BOOTLOADER; QFN16-EP	
61	U5, U6, U10, U11	-	4	MAX3373EEKA+	ANALOG DEVICES	MAX3373EEKA+	IC; TRANS; +/-15KV ESD-PROTECTED; 16MPBS; DUAL LOW-VOLTAGE LEVEL TRANSLATOR; SOT23-8	
62	U7, U8	-	2	74LVC1G86GV	NXP	74LVC1G86GV	IC; XOR; 2-INPUT EXCLUSIVE-OR GATE; SOT753	
63	U9	-	1	MAX16922ATPH/V+	ANALOG DEVICES	MAX16922ATPH/V+	IC; CONV; 2.2MHZ; DUAL; STEP-DOWN DC-DC CONVERTER; DUAL LDOS AND RESET; TQFN20-EP	
64	VDD_REF	-	1	PBC02SAAN	SULLINS ELECTRONICS CORP.	PBC02SAAN	CONNECTOR; MALE; THROUGH HOLE; BREAKAWAY; STRAIGHT; 2PINS	
65	Y1	-	1	CX2016DB16000D0WZRC1	KYOCERA	16MHZ	CRYSTAL; SMT 2.0 MM X 1.6 MM; 8PF; 16MHZ; +/-25PPM; +/-40PPM	
66	Y2	-	1	ECS-250-18-33Q-DS	ECS INC	25MHZ	CRYSTAL; SMT 3.2X2.5; 18PF; 25MHZ; +/-30PPM; +/-100PPM	
67	PCB	-	1	MAX96751	ANALOG DEVICES	PCB	PCB-MAX96751	
68	EV_KIT_BOX2	-	1	GKIFYACRYL-001	GEEKIFY	N/A	EVKIT PART-ACCESSORY; PLASTIC COVER; TOP PLASTIC COVER WITH ADI LOGO	
69	EV_KIT_BOX2	-	1	GKIFYACRYL-002	GEEKIFY	N/A	EVKIT PART-ACCESSORY; PLASTIC COVER; BOTTOM PLASTIC COVER WITHOUT ADI LOGO	
70	EV_KIT_BOX2	-	4	BS34CL06X25AP	BUMPER SPECIALTIES INC.	N/A	BUMPER; CLEAR-CYLINDRICAL SHAPE; 0.375D/0.125H; POLYURETHANE	
71	EV_KIT_BOX2	-	4	4802	KEYSTONE	N/A	STANDOFF; MALE_FEMALE-THREADED; HEX; 4-40IN; 0.50IN; NYLON	
72	EV_KIT_BOX2	-	4	1902D	KEYSTONE	N/A	STANDOFF; FEMALE-THREADED; HEX; 4-40IN; 3/4IN; NYLON	
73	EV_KIT_BOX2	-	8	NY PMS 440 0025 PH	B&F FASTENER SUPPLY	N/A	MACHINE SCREW; PHILLIPS; PAN; 4-40; 1/4IN; NYLON	
74	EV_KIT_BOX3	-	5	NPC02SXON-RC	SULLINS ELECTRONICS CORP.	N/A	CONNECTOR; FEMALE; MINI SHUNT; 0.100IN CC; OPEN TOP; JUMPER; STRAIGHT; 2PINS	
75	PACKOUT_BOX	DNI	1	AK67421-0.5	ASSMANN	N/A	CONNECTOR; USB CABLE; MALE-MALE; USB_2.0; 5PINS-4PINS; 500MM	
76	PACKOUT_BOX	DNI	1	WSU120-2000	TRIAD MAGNETICS	N/A	ACCESSORY; WALL ADAPTER; VI(90-284VAC); VO-(12VDC); 6FT	
77	C50, C51, C68, C70	DNP	0	GRM155R71E104KE14;C1005X7R1E104K050BB;TMK105B7104KVH;C GJ2B3X7R1E104K050BB	MURATA;TDK;TAIYO YUDEN;TDK	0.1UF	CAPACITOR; SMT (0402); CERAMIC CHIP; 0.1UF; 25V; TOL=10%; MODEL=GRM SERIES; TG=-55 DEGC TO +125 DEGC; TC=X7R	
78	J9	DNP	0	D4S20L-40MA5-Z	ROSENBERGER	D4S20L-40MA5-Z	EVKIT -CONNECTOR; MALE; THROUGH HOLE; D4S20L-40MA5 SERIES; RIGHT ANGLE; 4PINS;	
79	R34, R76	DNP	0	CRCW060342K2FK	VISHAY DALE	42.2K	RESISTOR; 0603; 42.2K OHM; 1%; 100PPM; 0.10W; THICK FILM	
80	R37, R38, R44, R77	DNP	0	ERA-3AB4872	PANASONIC	48.7K	RESISTOR; 0603; 48.7K OHM; 0.1%; 25PPM; 0.1W; METAL FILM	
81	R39	DNP	0	CRCW06030000ZS;MCR03EZPJ000;ERJ-3GEY0R00	VISHAY DALE;ROHM;PANASONIC		0 RESISTOR; 0603; 0 OHM; 0%; JUMPER; 0.10W; THICK FILM	
82	R78, R79	DNP	0	RC1608J000CS;CR0603-J-000ELF;RC0603JR-070RL	SAMSUNG ELECTRONICS;BOURNS;YAGEO PH		0 RESISTOR; 0603; 0 OHM; 5%; JUMPER; 0.10W; THICK FILM	
TOTAL			232					



MAX96751EV Schematics

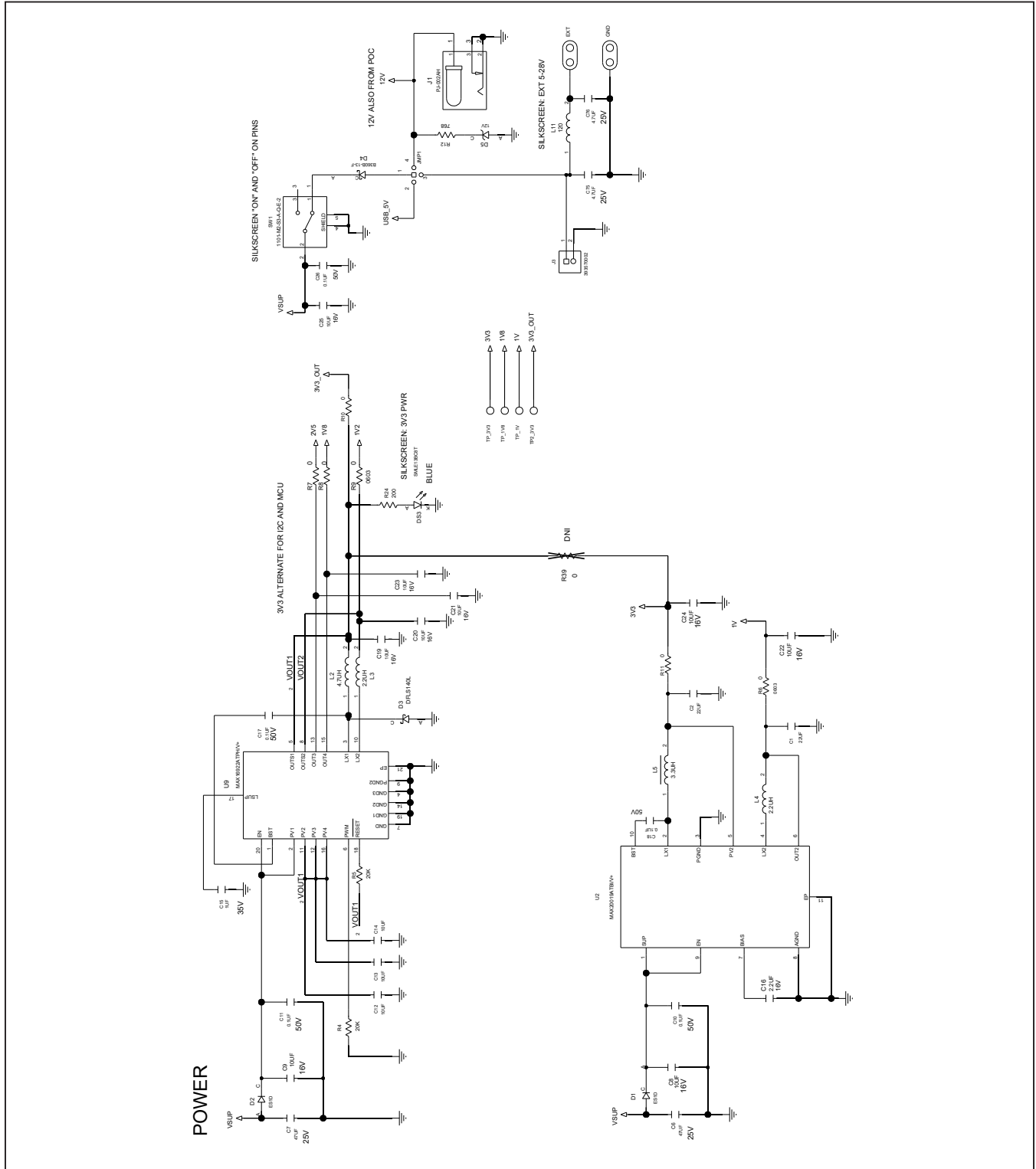

MAX96751EV Schematics (continued)

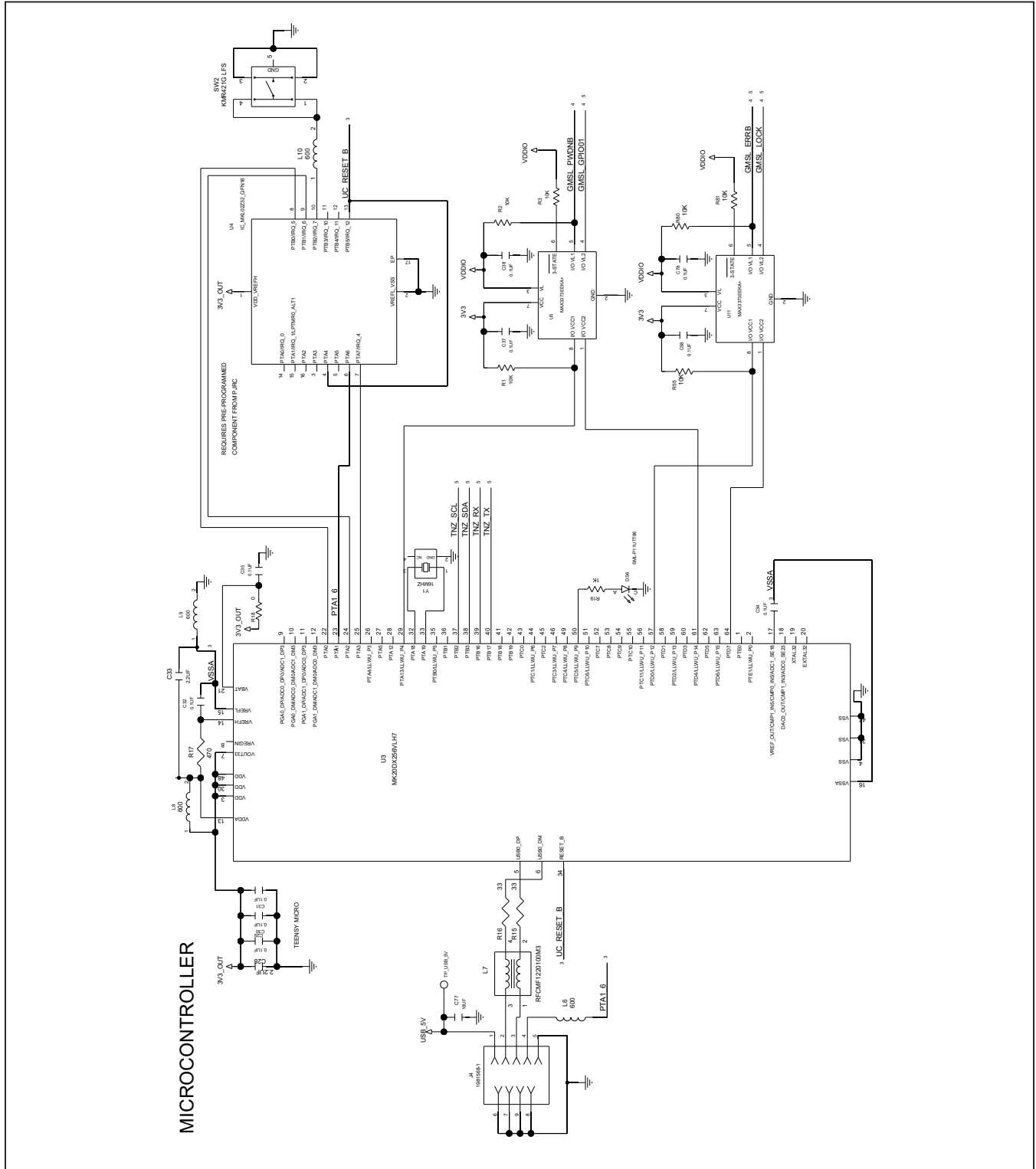

MAX96751EV Schematics (continued)

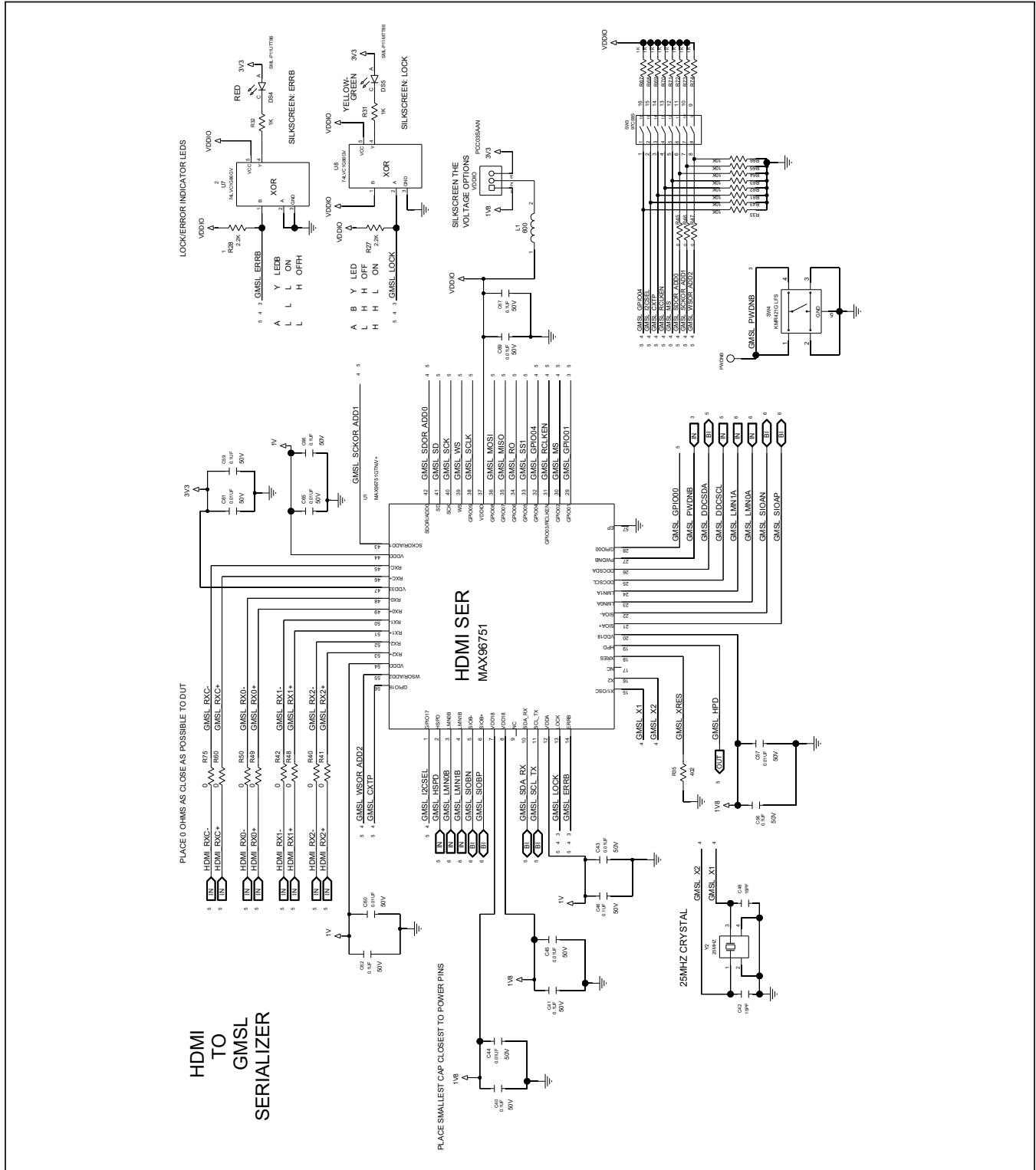

MAX96751EV Schematics (continued)

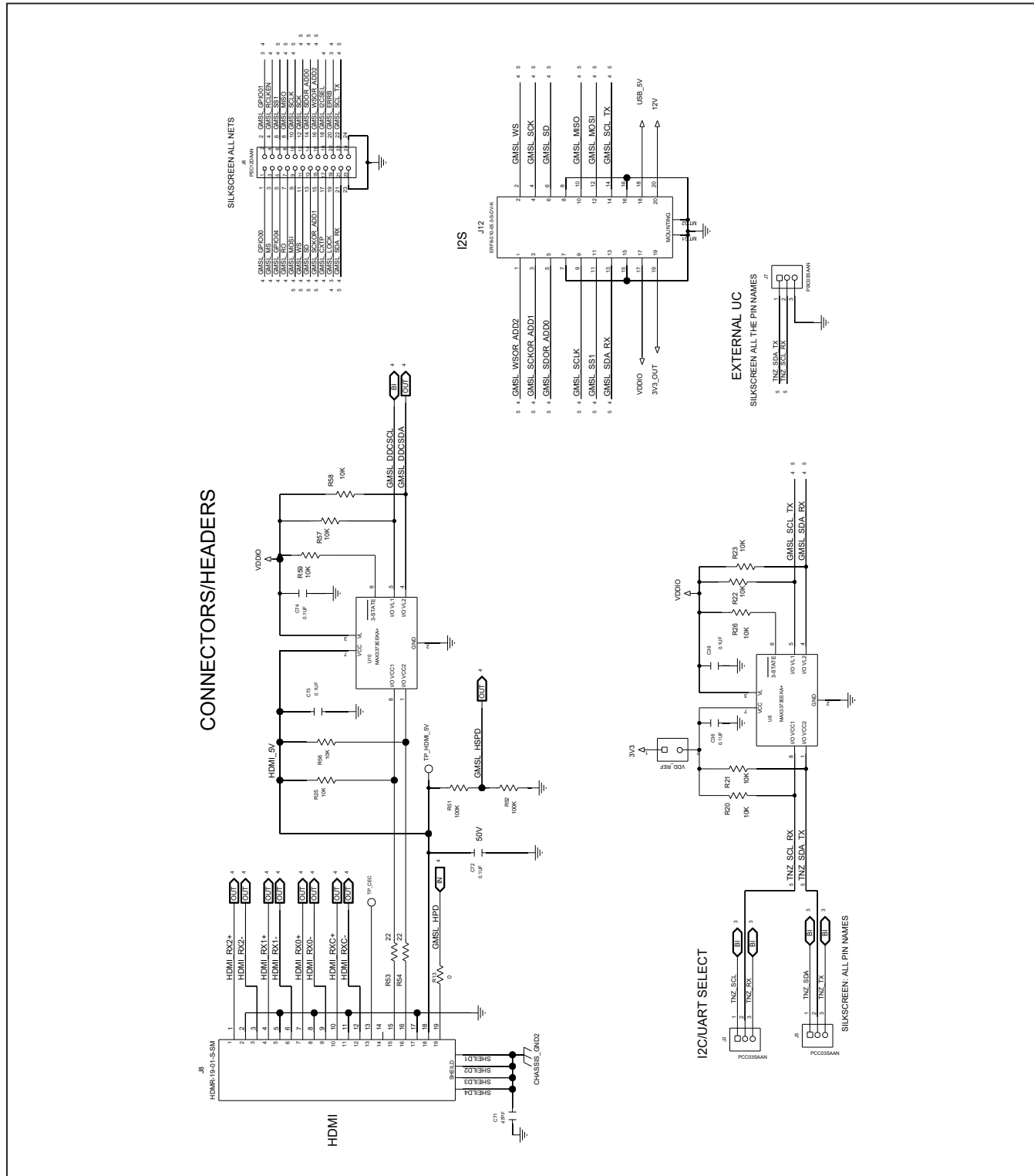

MAX96751EV Schematics (continued)

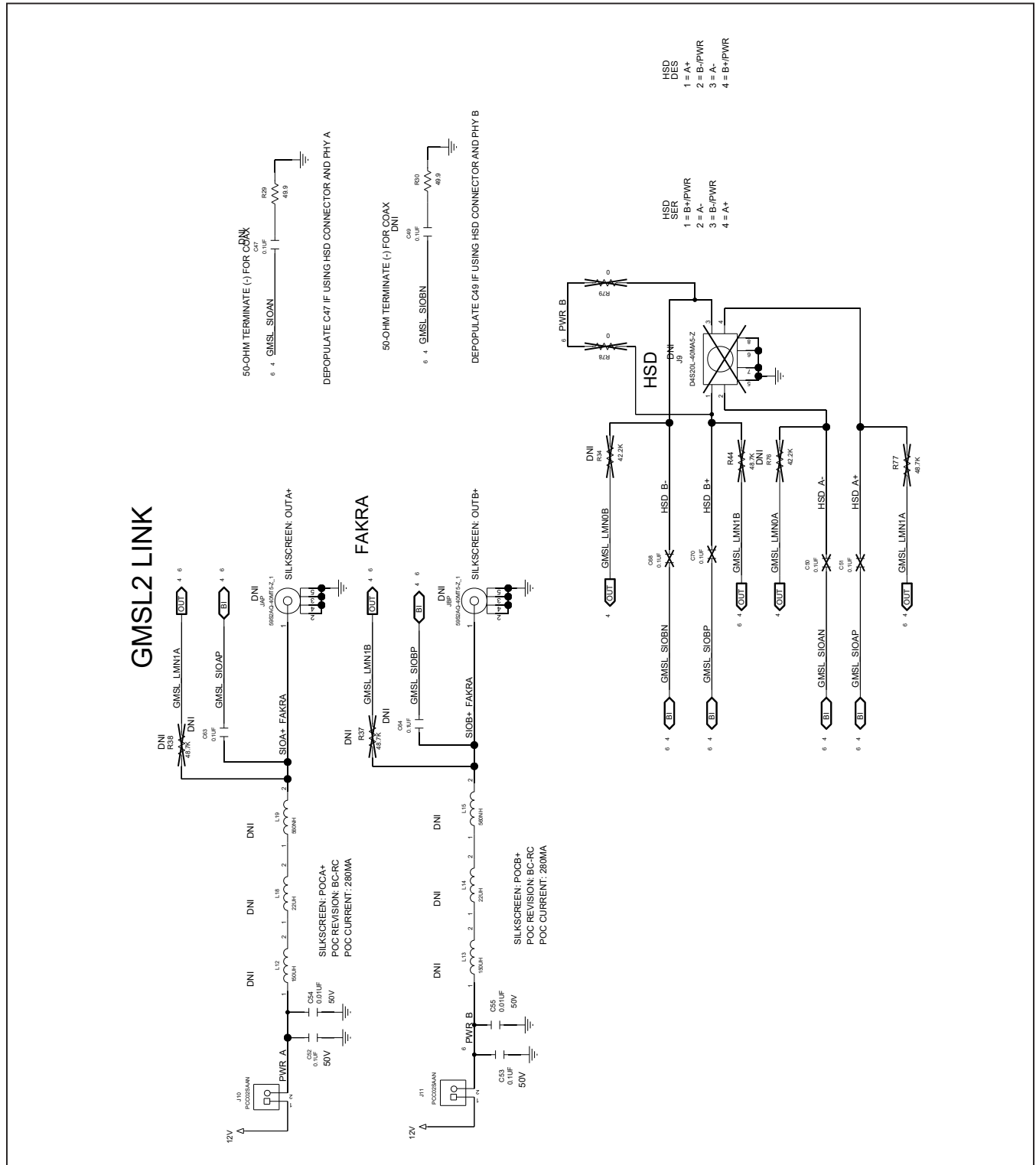

MAX96751EV PCB Layouts

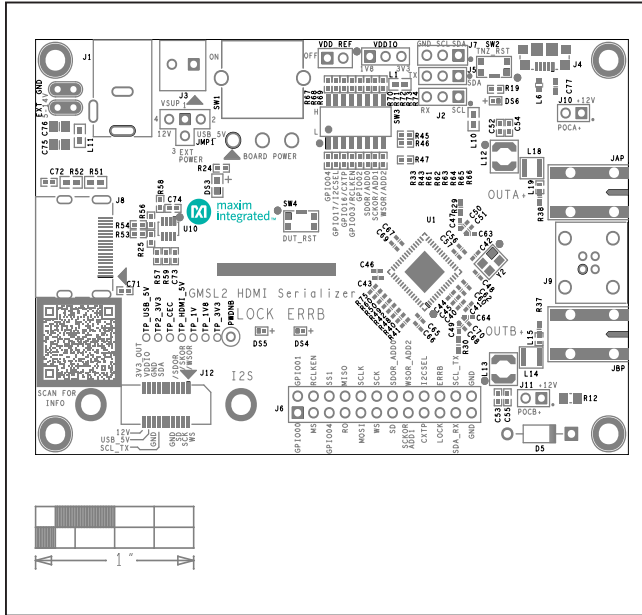

MAX96751 EV Kit Component Placement Guide—Top Silkscreen

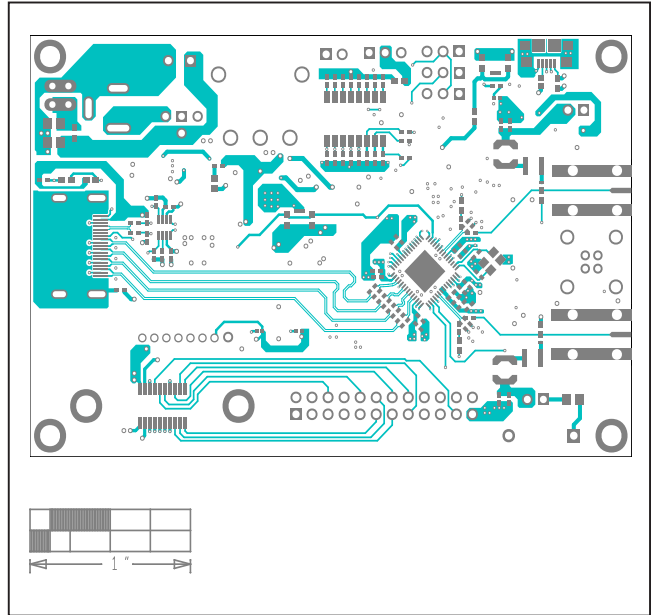

MAX96751 EV Kit PCB Layout—Top Layer

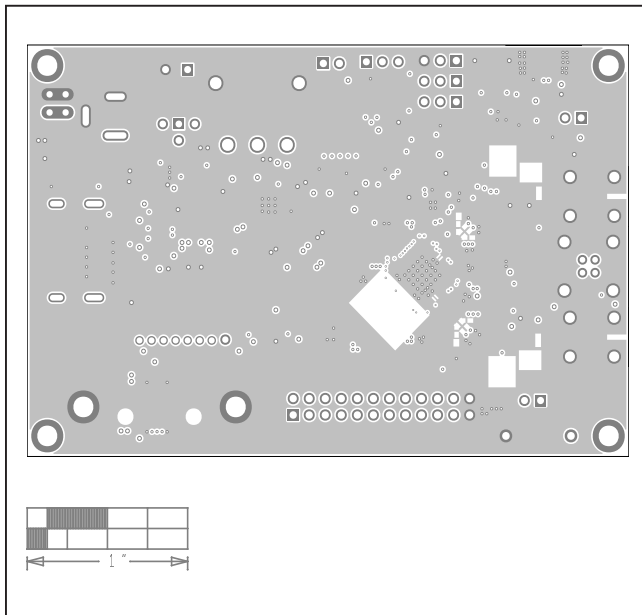

MAX96751 EV Kit PCB Layout—Internal 2

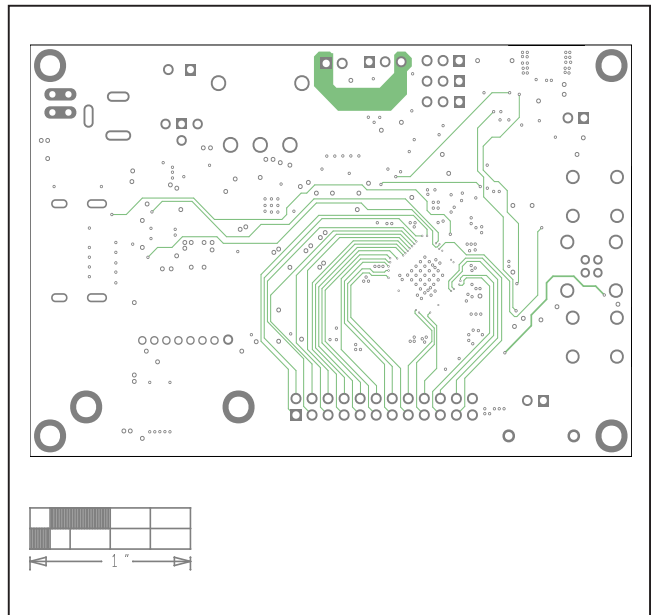

MAX96751 EV Kit PCB Layout—Internal 3



MAX96751EV PCB Layouts (continued)

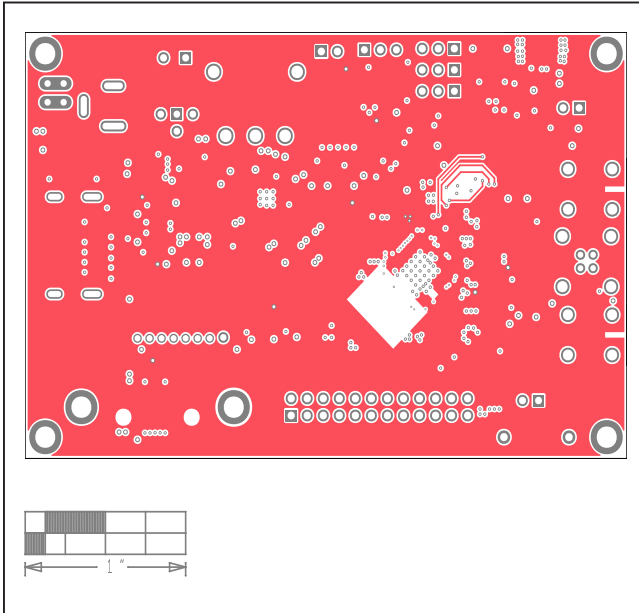

MAX96751 EV Kit PCB Layout—Internal 4

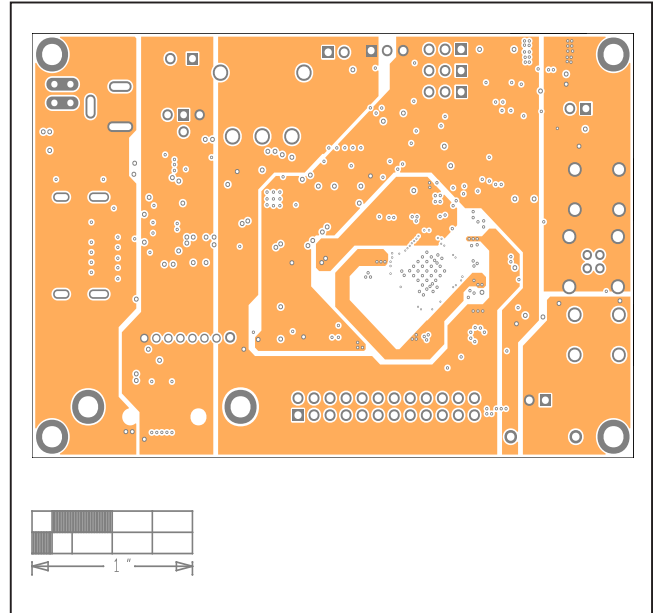

MAX96751 EV Kit PCB Layout—Internal 5

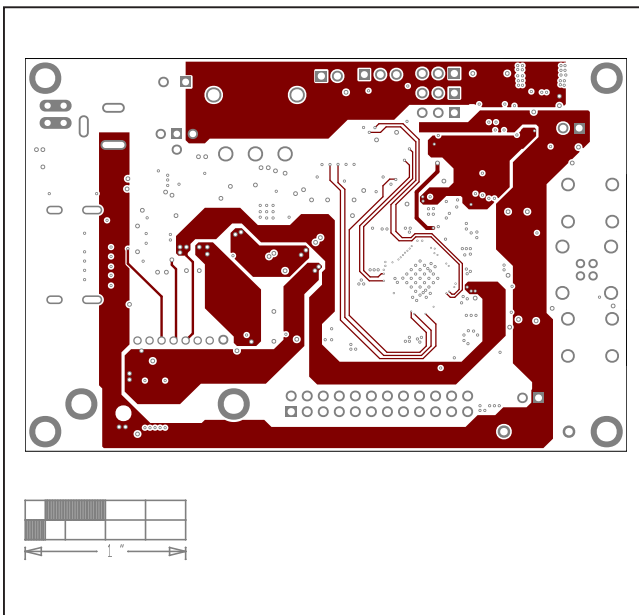

MAX96751 EV Kit PCB Layout—Internal 6

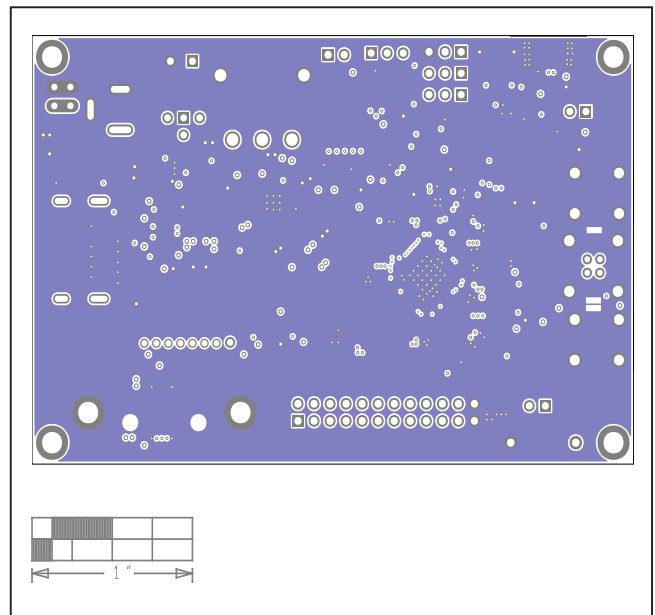

MAX96751 EV Kit PCB Layout—Internal 7

MAX96751EV PCB Layouts (continued)

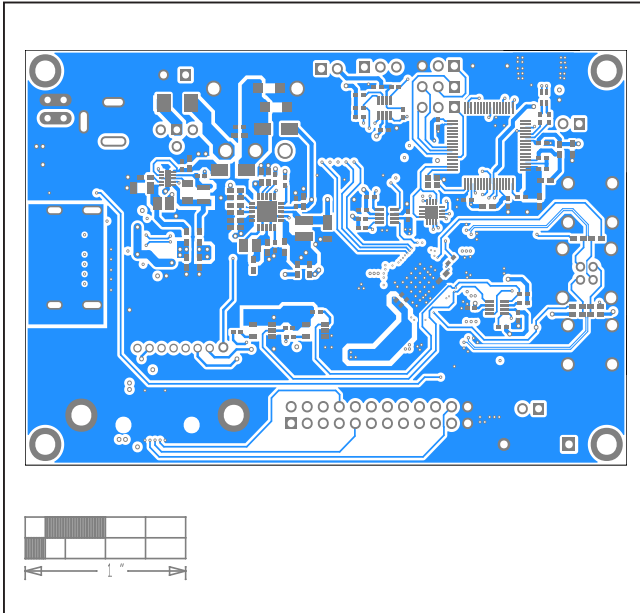

MAX96751 EV Kit PCB Layout—Bottom

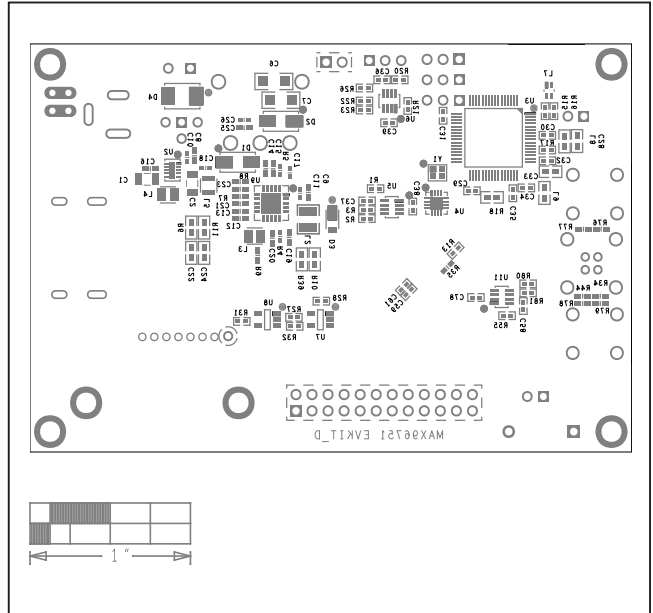

MAX96751 EV Kit PCB Layout—Bottom Silkscreen

Revision History

REVISION NUMBER	REVISION DATE	DESCRIPTION	PAGES CHANGED
0	11/23	Initial release	—



Information furnished by Analog Devices is believed to be accurate and reliable. However, no responsibility is assumed by Analog Devices for its use, nor for any infringements of patents or other rights of third parties that may result from its use. Specifications subject to change without notice. No license is granted by implication or otherwise under any patent or patent rights of Analog Devices. Trademarks and registered trademarks are the property of their respective owners.

# Mouser Electronics

Authorized Distributor

Click to View Pricing, Inventory, Delivery & Lifecycle Information:

[Analog Devices Inc.:](#)

[MAX96751HSDEVKIT#](#) [MAX96751COAXEVKIT#](#)