

REVISIONS			
REV.	DESCRIPTION	DATE	APPROVED
A00	INITIAL RELEASE	04/17/12	D.N.

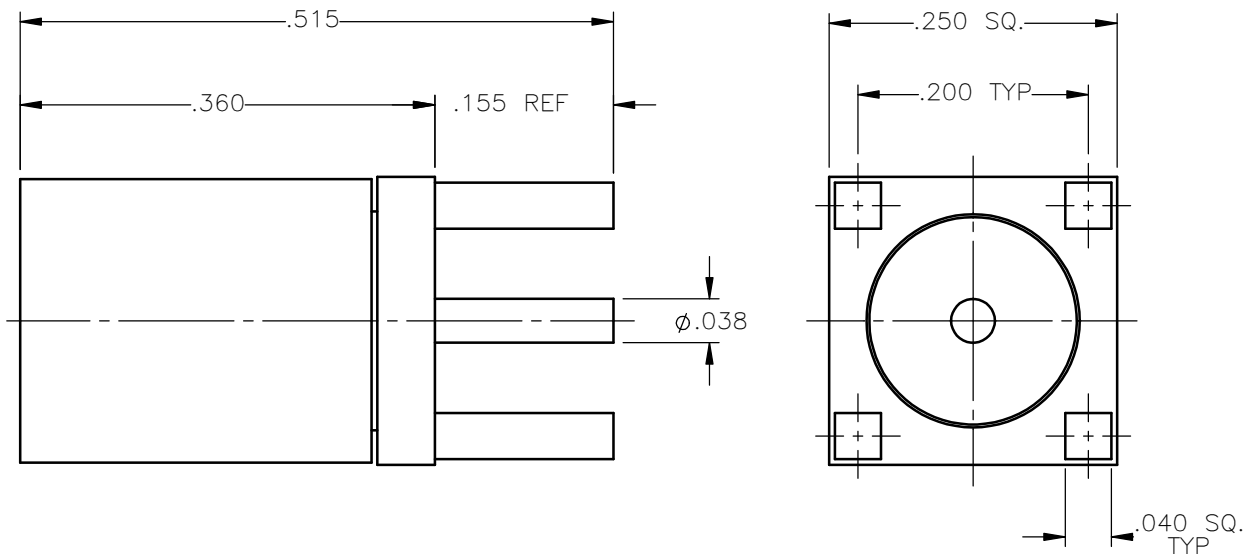



NOTES:

MATERIALS:

1. BODY & SLEEVE = BRASS PER ASTM B16, ALLOY C36000, TEMPER H02.
2. INSULATOR = VIRGIN WHITE TEFLON PER ASTM D1710, GRADE 1, TYPE I, CLASS "B".
3. CONTACT & SPRING = BERYLLIUM COPPER PER ASTM B196, ALLOY C17300, TEMPER TD04.

FINISHES:

1. BODY & SLEEVE = SILVER PLATE PER QQ-S-365, TYPE III, GRADE A, .0002 TO .0003 THICK OVER COPPER FLASH PER MIL-C-14550, .000010 TO .000030 THICK, TREAT WITH TARNABAN.
2. CONTACT = GOLD PLATE PER MIL-G-45204, TYPE II, CLASS 1, GRADE C, OVER .00010 TO .00020 STRESS FREE SULFAMATE NICKEL PER QQ-N-290.
3. SPRING = NICKEL PLATE PER QQ-N-290, CLASS 1, GRADE G, EXCEPT .0001 TO .0002 THICK OVER .00005 TO .0001 THICK COPPER PER MIL-C-14550.

UNLESS OTHERWISE SPECIFIED DIMENSIONS ARE IN INCHES TOLERANCES ON	DWN:	DATE	 Property of Radiall This document cannot be reproduced or communicated to a third party without prior written permission of RADIALL.			
	D.N.	04/17/12				
DECIMAL	ANGLE	CHKD:	DATE	SLB STRAIGHT FEMALE PLUG P.C.B. MOUNT RECEPTACLE		
		J.S.	04/17/12			
		APVD:	DATE			
		J.M.	04/17/12			
REFERENCE:	MATERIALS & FINISHES:		SIZE	FSCM NO.	DWG NO.	REV
ORIGINATED: D.N. DATE: 04/17/12	SEE NOTES		A	19505	3025-6511-005	A00
			SCALE 6:1	THIRD ANGLE PROJECTION		SHEET 1 OF 1

3025-6511-005

Mouser Electronics

Authorized Distributor

Click to View Pricing, Inventory, Delivery & Lifecycle Information:

Radial:

[3025-6511-005](#)