

**SMT BOARD TO BOARD ADAPTOR H3**

**R107.064.920**

**REEL OF 100**

Series : IMP

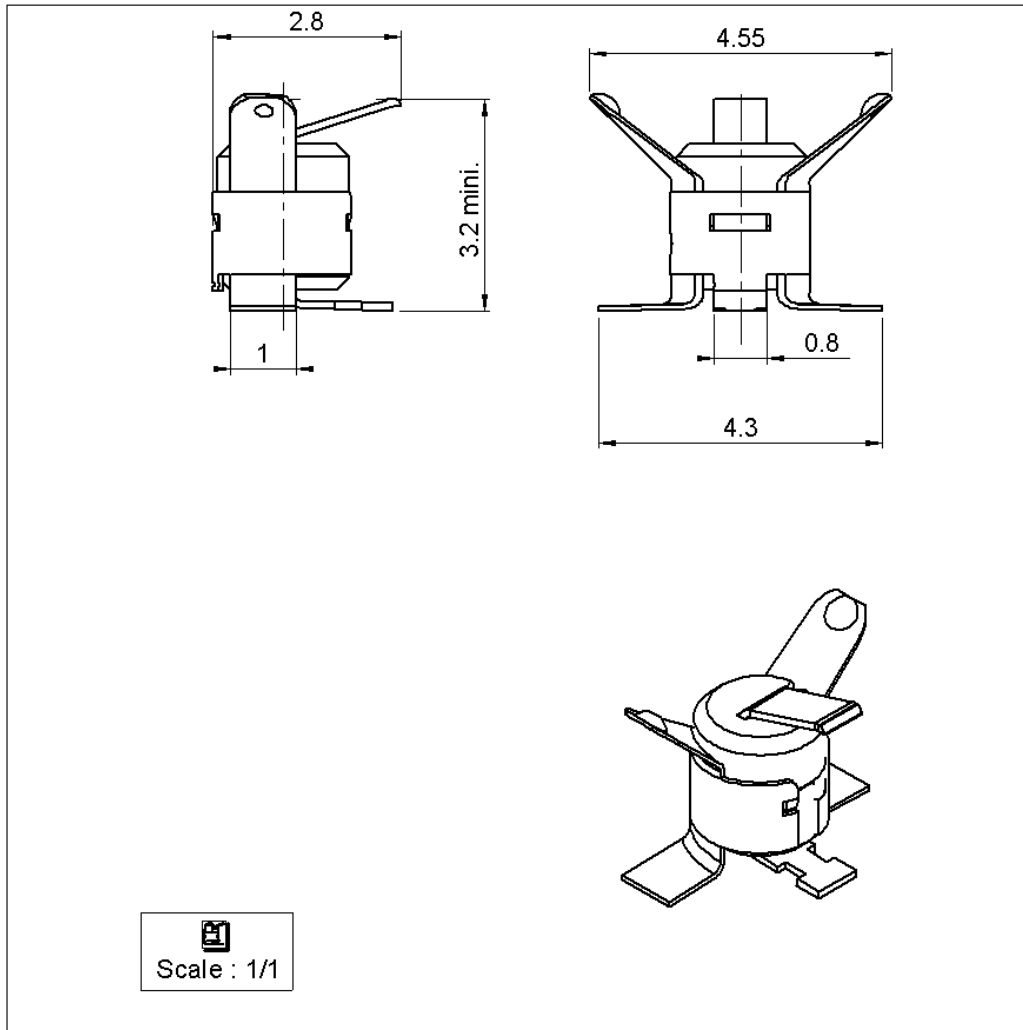

All dimensions are in mm.



COMPONENTS	MATERIALS	PLATINGS (µm)
BODY	BERYLLIUM COPPER	GOLD 0.5 OVER NICKEL 2
CENTER CONTACT	BERYLLIUM COPPER	GOLD 0.5 OVER NICKEL 2
OUTER CONTACT	BERYLLIUM COPPER	GOLD 0.5 OVER NICKEL 2
INSULATOR	POLYETHER ETHERCETONE 30% GF	
GASKET		
OTHERS PARTS		
-	-	-
-	-	-

Issue : 0417 A

In the effort to improve our products, we reserve the right to make changes judged to be necessary.



**SMT BOARD TO BOARD ADAPTOR H3**

**R107.064.920**

**REEL OF 100**

Series : IMP

**PACKAGING**

**SPECIFICATION**

Standard	Unit	Other
<b>100</b>	<b>'W' option</b>	<b>Contact us</b>

**ELECTRICAL CHARACTERISTICS**

**ENVIRONMENTAL**

Impedance		<b>50</b> Ω
Frequency		<b>0-6</b> GHz
VSWR	<b>1.10</b> +	<b>0.030</b> x F(GHz) Maxi
Insertion loss		<b>0.2</b> √F(GHz) dB Maxi
RF leakage	- (	- F(GHz)) dB Maxi
Voltage rating		<b>100</b> Veff Maxi
Dielectric withstanding voltage		<b>350</b> Veff mini
Insulation resistance		<b>3000</b> MΩ mini

Operating temperature	<b>-40/+90</b> ° C
Hermetic seal	Atm.cm3/s
Panel leakage	

**OTHERS CHARACTERISTICS**

Assembly instruction

Others :  
Weight reel : 75 g

**MECHANICAL CHARACTERISTICS**

Center contact retention		
Axial force – Mating end		N mini
Axial force – Opposite end		N mini
Torque		N.cm mini
Recommended torque		
Mating		N.cm
Panel nut		N.cm
Mating life	<b>20</b>	Cycles mini
Weight	<b>0.020</b>	g

Issue : 0417 A

In the effort to improve our products, we reserve the right to make changes judged to be necessary.



**SMT BOARD TO BOARD ADAPTOR H3**

**R107.064.920**

**REEL OF 100**

Series : IMP

**SOLDER PROCEDURE**

1. Deposition of solder paste 'Sn Ag4 Cu0.5' on mounting zone by screen printing application. We recommend a low residue flux.  
We advise a thickness of 150 microns ( 5.850 microinch ). Verify that the edges of the zone are clean.
2. Placement of the receptacle on the mounting zone with an automatic machine of 'pick and place' type. Video camera is recommended for the positioning of the component. Adhesive agents must not be used on the receptacle.
3. This process of soldering has been tested with convection oven.  
Below please find, the typical profile to use.
4. Cleaning of printed circuit boards.
5. Checking of solder joints and position of the component by visual inspection.

**TEMPERATURE PROFILE**

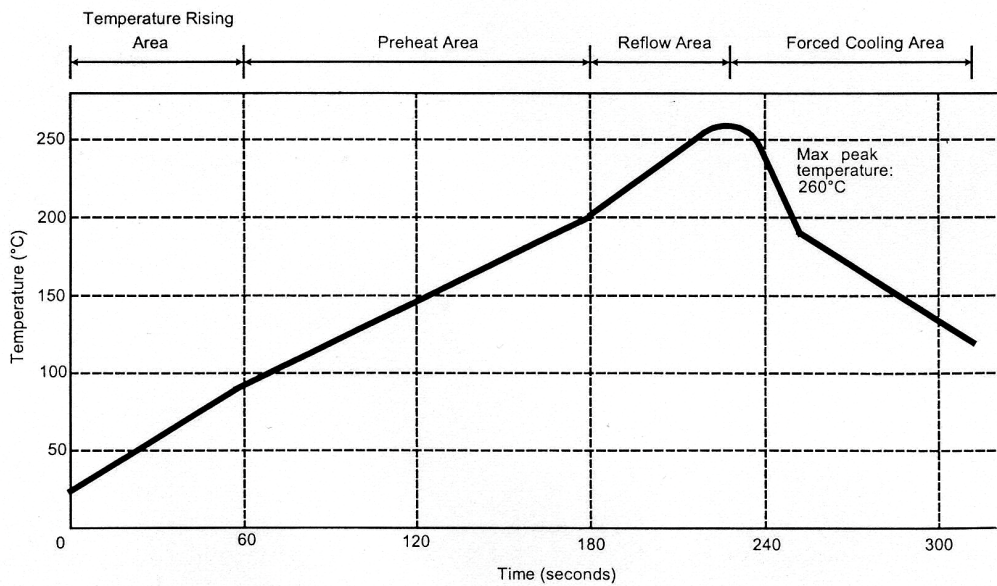

Parameter	Value	Unit
Temperature rising Area	1 - 4	°C/sec
Max Peak Temperature	260	°C
Max dwell time @260°C	10	sec
Min dwell time @235°C	20	sec
Max dwell time @235°C	60	sec
Temperature drop in cooling Area	-1 to -4	°C/sec
Max dwell time above 100°C	420	sec

Issue : 0417 A

In the effort to improve our products, we reserve the right to make changes judged to be necessary.



**SMT BOARD TO BOARD ADAPTOR H3**

**R107.064.920**

**REEL OF 100**

Series : IMP

**IMP-SERIES-INFORMATION**

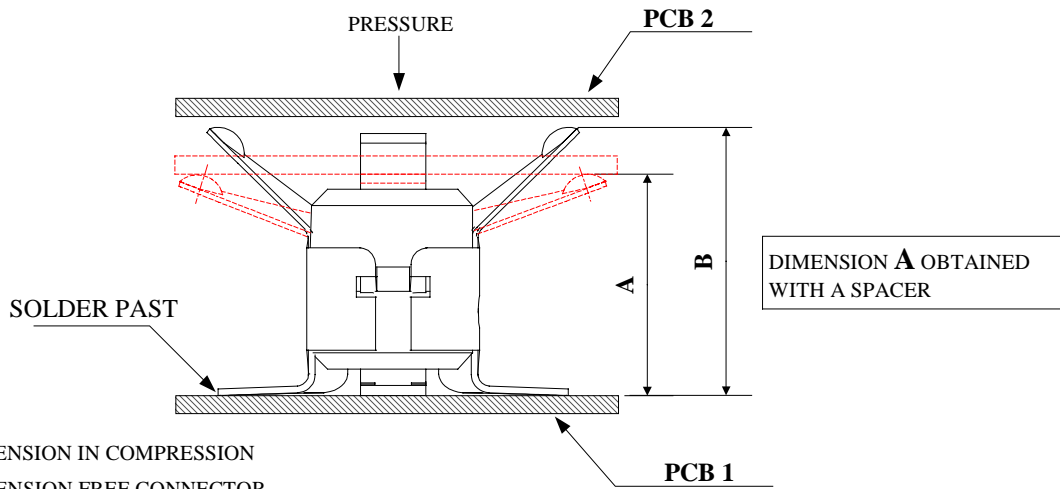

**ELASTICITY**  
**TABLE OF CORRESPONDENCE**

<b>A</b> <i>CONNECTOR COMPRESSION ALLOWABLE</i> <i>(Dimension obtained in compression)</i>	<b>B</b> <i>PRODUCT DIMENSION AFTER COMPRESSION</i> <i>(Dimension obtained after elastic return)</i>
3.1 mm	3.20 mm mini
3 mm	3.15 mm mini
2.9 mm	3.10 mm mini
2.8 mm	3.05 mm mini
2.7 mm	3.00 mm mini

THE CONNECTOR IS NOT A SPACER, SO DIMENSION A MUST BE ENSURED WITH AN ADDED PIECE PART SETTED 10 mm MAX. FAR FROM THE IMP CONNECTOR.

SHADOW OF IMP RECEPTACLE FOR VIDEO CAMERA

All dimensions are in mm.

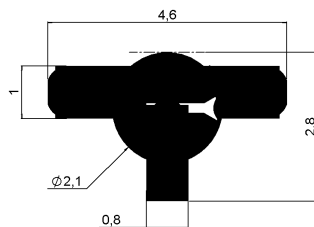

Issue : 0417 A

In the effort to improve our products, we reserve the right to make changes judged to be necessary.



**SMT BOARD TO BOARD ADAPTOR H3**

**R107.064.920**

**REEL OF 100**

Series : IMP

**IMP SERIES INFORMATION**

**PCB 1**

All dimension are in mm

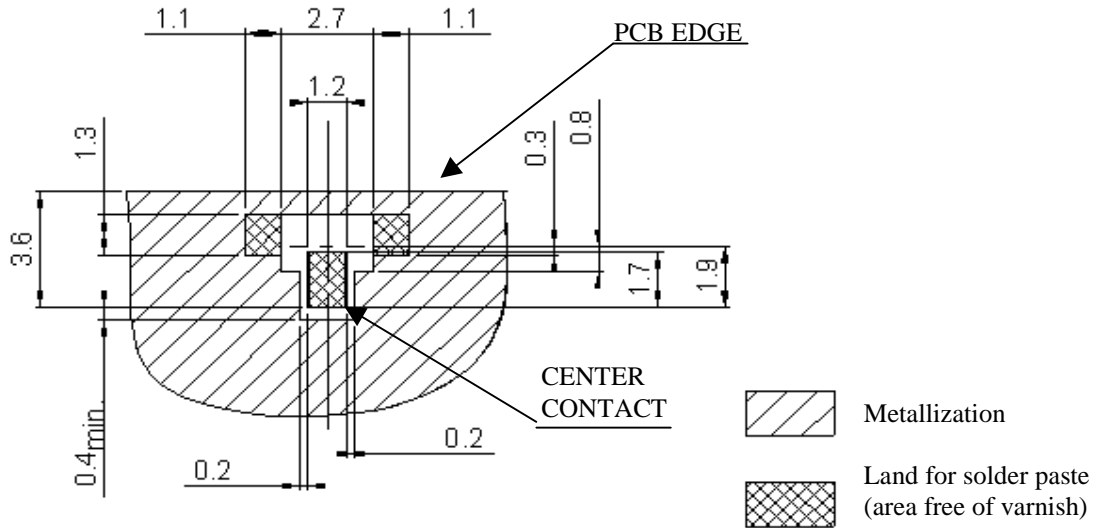

Vias and transmission line inside PCB are not represented.  
The impedance of the transmission line should be 50 ohms

**PCB 2**

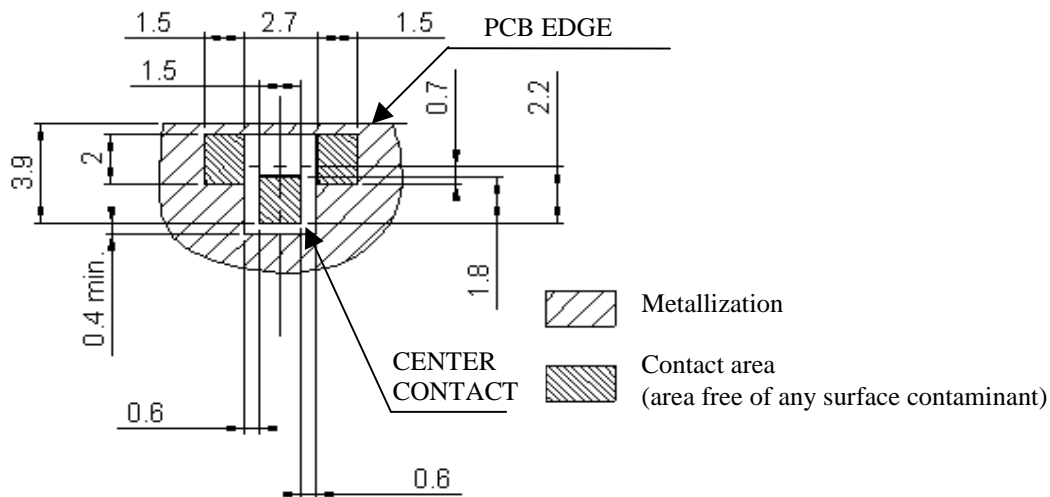

Vias and transmission line inside PCB are not represented.  
The impedance of the transmission line should be 50 ohms

Issue : 0417 A

In the effort to improve our products, we reserve the right to make changes judged to be necessary.



SMT BOARD TO BOARD ADAPTOR H3

**R107.064.920**

REEL OF 100

Series : IMP

IMP SERIES INFORMATION

The aspiration port should be in contact with the insulator

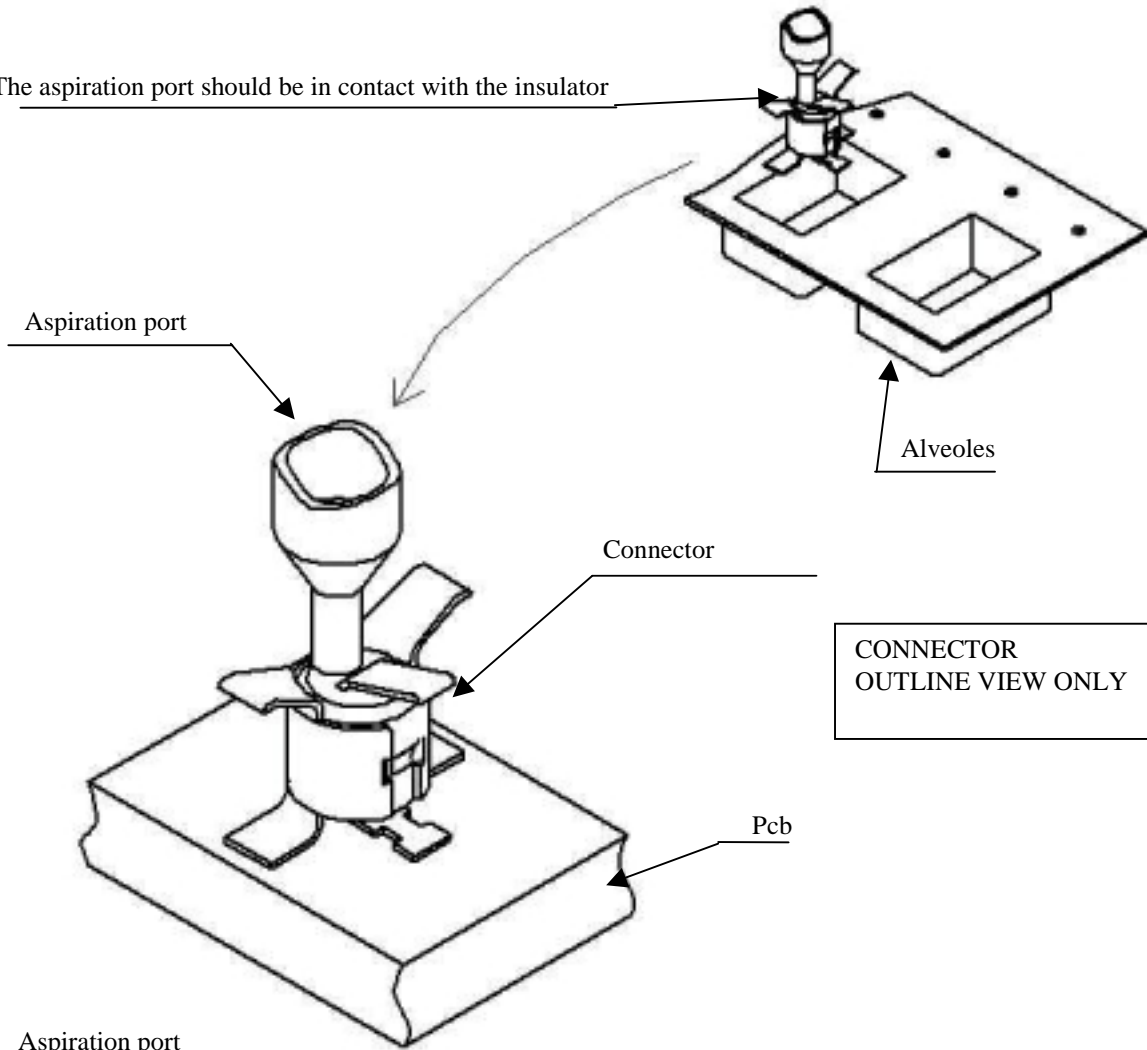

Aspiration port

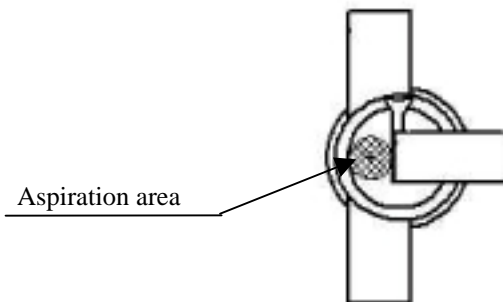
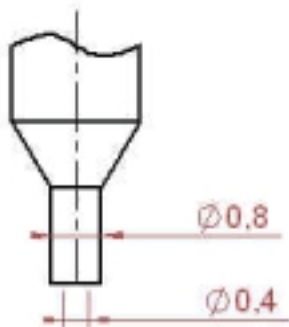

Issue : 0417 A

In the effort to improve our products, we reserve the right to make changes judged to be necessary.



SMT BOARD TO BOARD ADAPTOR H3

**R107.064.920**

REEL OF 100

Series : IMP

IMP SERIES INFORMATION

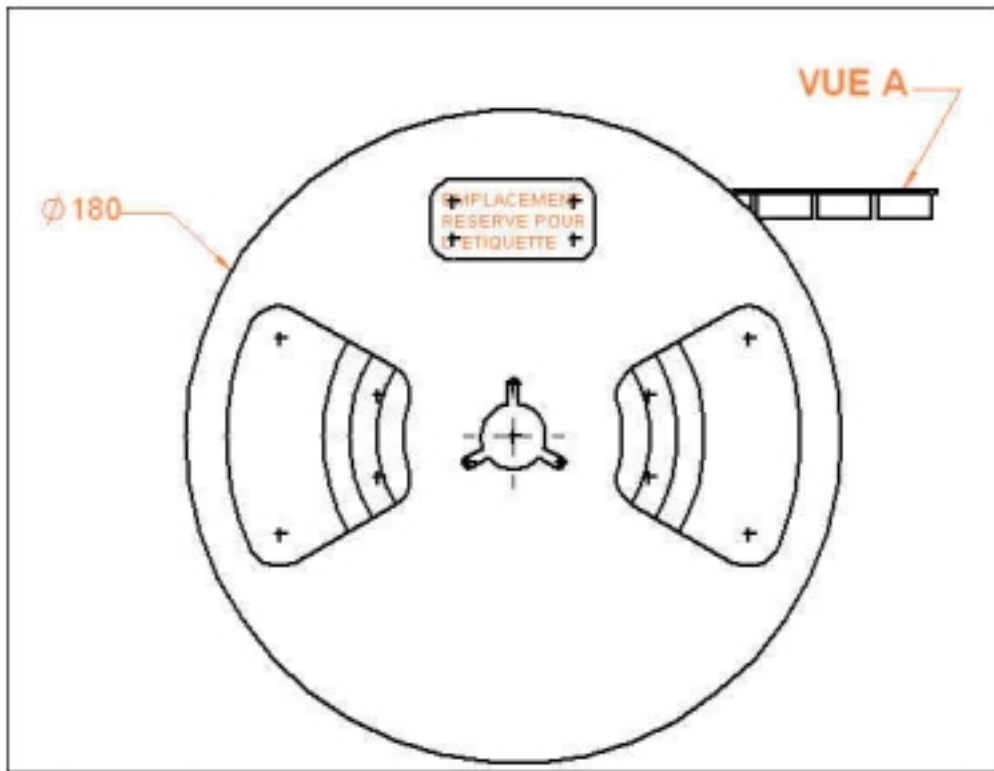

CONNECTOR  
OUTLINE VIEW ONLY

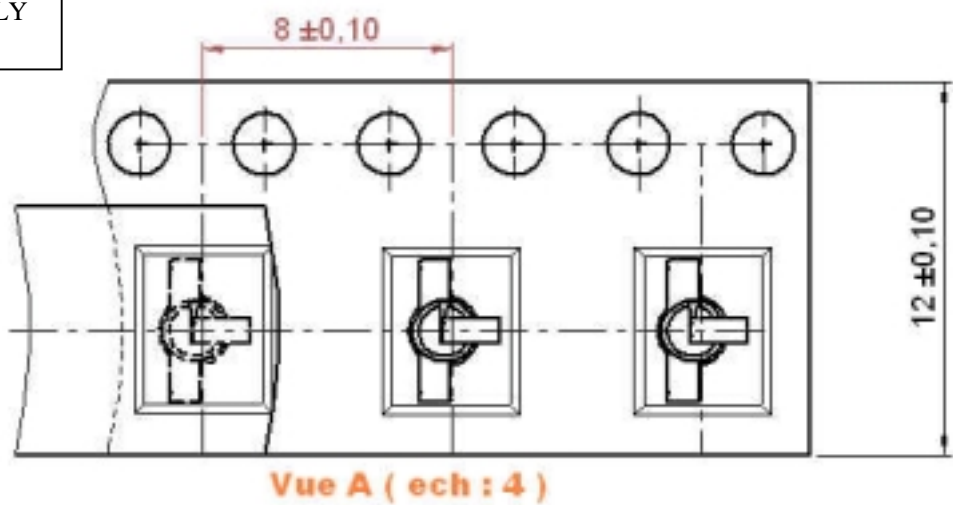

Issue : 0417 A

In the effort to improve our products, we reserve the right to make changes judged to be necessary.



# Mouser Electronics

Authorized Distributor

Click to View Pricing, Inventory, Delivery & Lifecycle Information:

[Radial:](#)

[R107064920](#)