

Liquid Cold Plates

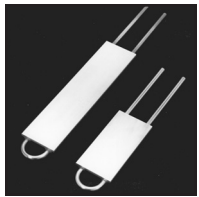

LIQUID COLD PLATES FOR HIGH-PERFORMANCE COMPONENTS AND SYSTEMS



180-10 & 180-11 SERIES

Liquid Cold Plates for Rectifiers and Power Diodes

GENERAL PURPOSE

Standard P/N	Cold Plate Body Nominal Dimensions				Overall Length in. (mm)	Overall Thermal Resistance (Plate to Inlet Water)	Weight lbs (grams)
	Length "A" in. (mm)	Width in. (mm)	Thickness in. (mm)	Channel Width in. (mm)			
180-10-6C	6.000 (152.4)	3.000 (76.2)	0.625 (15.9)	1.250 (31.8)	13.406 (340.5)	0.084°C/W @ 1.5 GPM	0.850 (385.56)
180-10-12C	12.000 (304.8)	3.000 (76.2)	0.625 (15.9)	1.250 (31.8)	19.406 (429.9)	0.041°C/W @ 1.5 GPM	1.700 (771.12)
180-10-24C	24.000 (609.6)	3.000 (76.2)	0.625 (15.9)	1.250 (31.8)	31.406 (797.7)	0.020°C/W @ 1.5 GPM	2.900 (1315.4)
180-11-6C	6.000 (152.4)	5.000 (127.2)	0.688 (17.5)	1.813 (46.1)	13.688 (347.7)	0.084°C/W @ 1.5 GPM	1.500 (680.40)
180-11-12C	12.000 (304.8)	5.000 (127.2)	0.688 (17.5)	1.813 (46.1)	19.688 (500.1)	0.041°C/W @ 1.5 GPM	2.867 (1300.47)
180-11-24C	24.000 (609.6)	5.000 (127.2)	0.688 (17.5)	1.813 (46.1)	31.688 (804.9)	0.020°C/W @ 1.5 GPM	5.730 (2599.13)

Material: aluminum, no finish. Tubing: copper (stainless steel tubing available on special order).

LOCAL THERMAL RESISTANCE PER DEVICE PLATE TO INLET WATER (°C/WATT)

Q to Q Device Spacing Inches	Flow - GPM				
	1/2	1	2	3	4
1.0 (25.4)	0.59	0.52	0.48	0.47	0.46
2.0 (50.8)	0.40	0.36	0.33	0.32	0.31
3.0 (76.2)	0.29	0.26	0.24	0.23	0.22

PERFORMANCE CHARACTERISTICS



MECHANICAL DIMENSIONS



Standard P/N	Length "A" in. (mm)
180-10-6C	6.000 in. (152.4)
180-10-12C	12.000 in. (304.8)
180-10-24C	24.000 in. (609.6)
180-11-6C	6.000 in. (152.4)
180-11-12C	12.000 in. (304.8)
180-11-24C	24.000 in. (609.6)

180-10 SERIES

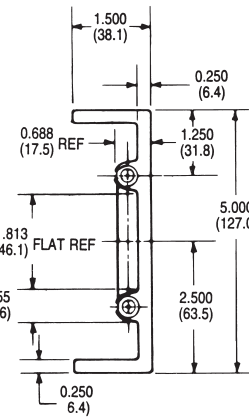
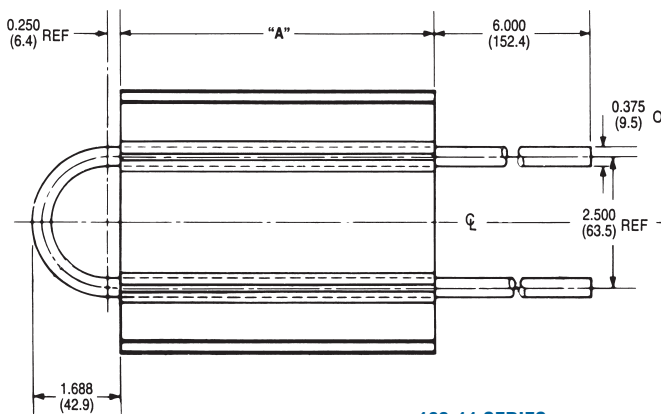

180-11 SERIES

Dimensions: in. (mm)



LIQUID COLD PLATES FOR HIGH-PERFORMANCE COMPONENTS AND SYSTEMS

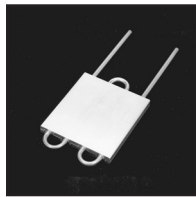

180-12 & 180-20 SERIES

Liquid Cold Plates for Rectifiers, Diodes, and Power Modules

GENERAL PURPOSE

Standard P/N	Cold PLate Body Nominal Dimensions			Mounting Surfaces	Overall Thermal Resistance (Plate to Inlet Water)		Weight lbs (grams)
	Length "A" in. (mm)	Width in. (mm)	Thickness in. (mm)		Overall Length in. (mm)		
180-12-6C	6.000 (152.4)	7.750 (196.9)	0.658 (16.7)	Single	13.406 (340.5)	0.038°C/W @ 1.0 GPM	2.270 (1029.67)
180-12-12C	12.000 (304.8)	7.750 (196.9)	0.658 (16.7)	Single	19.406 (492.9)	0.018°C/W @ 1.0 GPM	4.300 (1950.48)
180-12-24C	24.000 (609.6)	7.750 (196.9)	0.658 (16.7)	Single	31.406 (797.7)	0.009°C/W @ 1.0 GPM	8.600 (3900.96)
180-20-6C	6.000 (152.4)	5.500 (139.7)	0.690 (17.5)	Double	13.125 (333.4)	0.038°C/W @ 1.0 GPM	1.090 (494.42)

LOCAL THERMAL RESISTANCE PER DEVICE PLATE TO INLET WATER (°C/WATT)

Q to Q Device Spacing Inches	Flow - GPM				
	1/2	1	2	3	4
1.0 (25.4)	0.76	0.67	0.62	0.59	0.57
2.0 (50.8)	0.58	0.49	0.43	0.40	0.39
3.0 (76.2)	0.42	0.34	0.30	0.28	0.27

PERFORMANCE CHARACTERISTICS

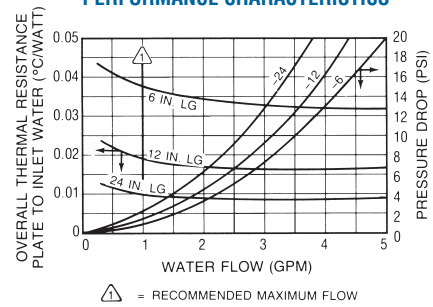

MECHANICAL DIMENSIONS

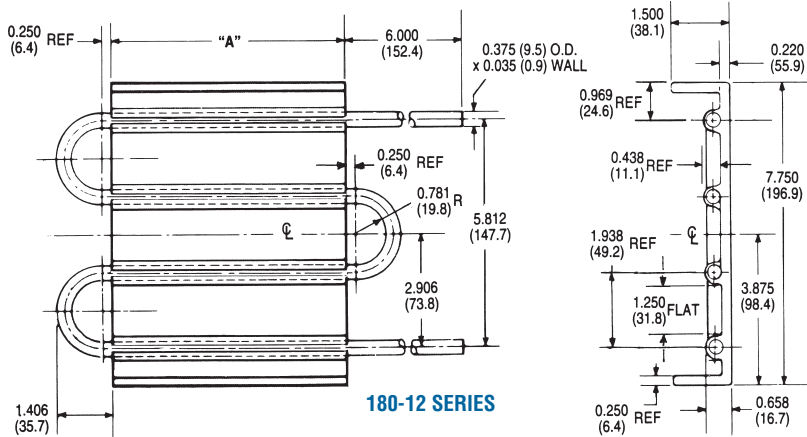

Standard P/N	Length "A" in. (mm)
180-12-6C	6.000 (152.4)
180-12-12C	12.000 (304.8)
180-12-24C	24.000 (609.6)
180-20-6C	6.000 (152.4)

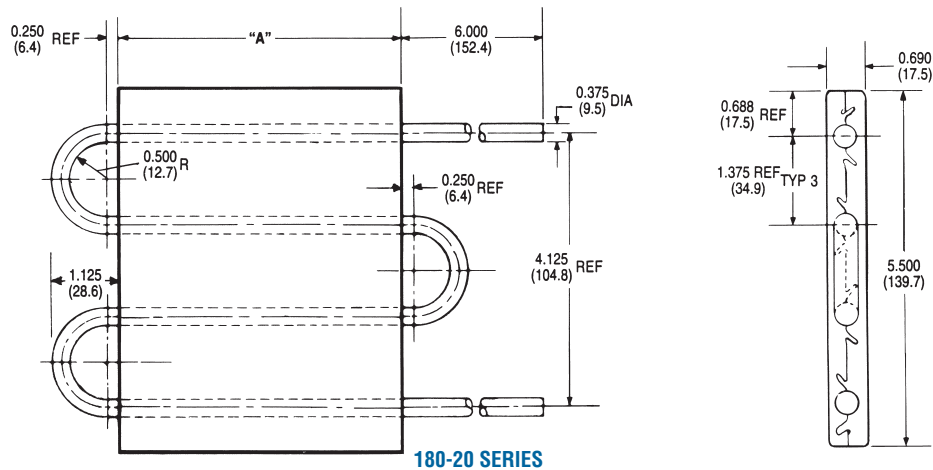

Dimensions: in. (mm)

Mouser Electronics

Authorized Distributor

Click to View Pricing, Inventory, Delivery & Lifecycle Information:

[Wakefield-Vette:](#)

[180-10-12C](#) [180-11-12C](#) [180-20-6C](#) [180-11-6C](#) [180-12-12C](#) [180-12-12SS](#) [180-12-6C](#) [180-11-24C](#) [180-10-6C](#)