

8 7 6 5 4 3 2 1

NOTES:

1. MOUNTING: Mounts in a $\phi .562 \pm .002$ [$\phi 16.56\text{mm} \pm .05$] panel hole on $.750$ [19.05mm] centers. Panel thickness $.031$ [$.8\text{mm}$] to $.187$ [4.75mm]. Panel hole should be deburred, but not chamfered.
2. ASSEMBLY: Insert lens through panel hole, slide lock washer onto lens barrel and twist on retaining ring. PCB mounted LEDs slide into lens when the panel cover is closed or the PCB card is inserted into the case.
3. MATERIAL: Lens-Polycarbonate, UL 94-V2
Lock Washer- FH Steel, Nickel plate
Retaining ring - Thermoplastic, U.L. 94 V0 Rated
4. U.S. & Foreign Pat. Issued & Pend.

| REVISIONS | | | | |
|-----------|------|---------------------------|---------|----------|
| ECN# | REV. | DESCRIPTION | DATE | INITIALS |
| | 001 | REVISED PER ECR111009AZ01 | 4-23-10 | SMU |

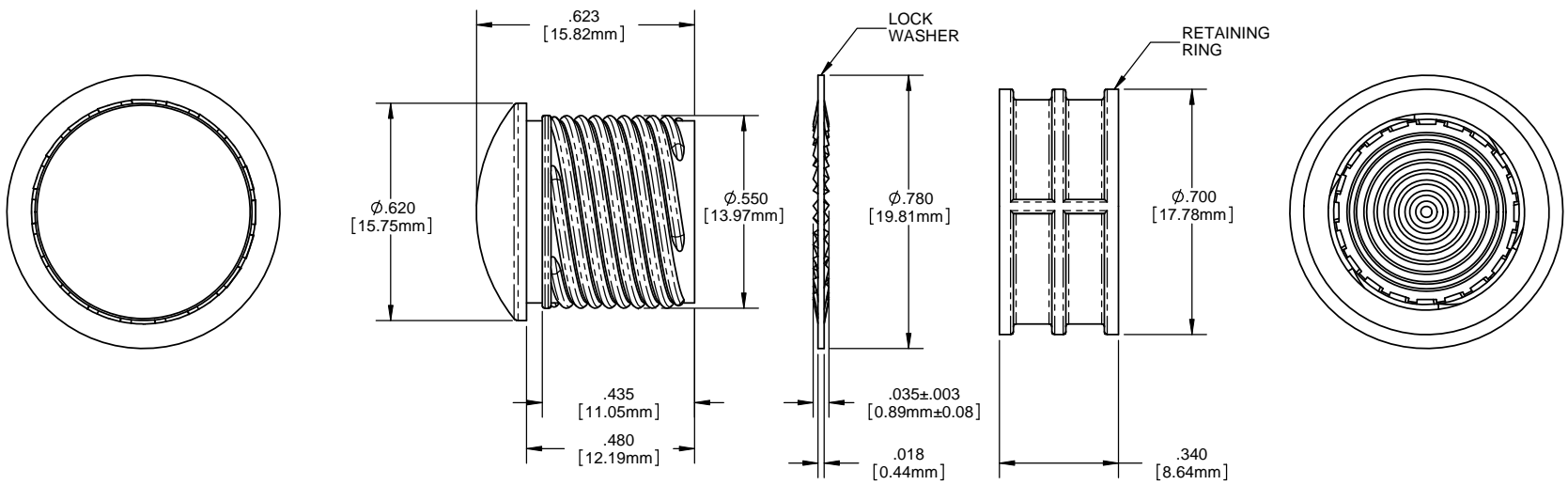
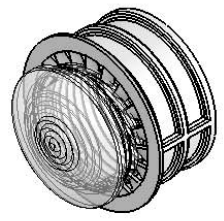

ORDERING CODE : **HMC 461 XXX**

MODEL

| LENS COLOR | |
|------------|--------------------|
| RTP | RED TRANSPARENT |
| ATP | AMBER TRANSPARENT |
| GTP | GREEN TRANSPARENT |
| BTP | BLUE TRANSPARENT |
| YTP | YELLOW TRANSPARENT |
| CTP | CLEAR TRANSPARENT |

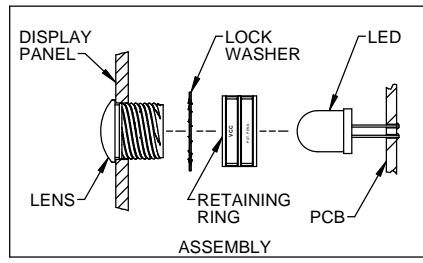

| | | | | | | | |
|--|---------------|----------------------|--|--------------|---------|--|-------------|
| UNLESS OTHERWISE SPECIFIED DIMENSIONS ARE IN INCHES | | MATERIAL | | SEE NOTES | | VISUAL COMMUNICATIONS COMPANY, INC. 190 Bosstick Boulevard, Suite 101 San Marcos, CA 92069 USA Phone (760) 560-1300 Fax (760) 560-1301 email vccsales@vccite.com | |
| ANGLES | DECIMALS | FINISH | | SEE NOTES | | TITLE: 10MM ROUND STANDARD THREADED FRESNEL LENS WITH SEAL | |
| $\pm 1^\circ$ | $\times .002$ | B | | APPROVAL | | DATE | SIZE |
| | $\times .010$ | DRAWN: | | SMU | 4-23-10 | | DWG. NO. |
| | $\times .005$ | CHECKED: | | DZ | 4-23-10 | | HMC 461 XXX |
| THIRD ANGLE PROJECTION | | DO NOT SCALE DRAWING | | SCALE: 4:1 | | REV | |
| THE INFORMATION CONTAINED IN THIS DRAWING IS THE SOLE PROPERTY OF VISUAL COMMUNICATIONS COMPANY, INC. REPRODUCTION IN PART OR AS A WHOLE WITHOUT THE WRITTEN CONSENT OF VISUAL COMMUNICATIONS COMPANY, INC. IS PROHIBITED. | | | | SHEET 1 OF 1 | | 001 | |

8 7 6 5 4 3 2 1

Mouser Electronics

Authorized Distributor

Click to View Pricing, Inventory, Delivery & Lifecycle Information:

VCC:

[HMC_461_ATP](#) [HMC_461_BTP](#) [HMC_461_CTP](#) [HMC_461_GTP](#) [HMC_461_RTP](#) [HMC_461_YTP](#)