



# IQS227-228ASEV02 Evaluation Kit User Guide

IQ Switch® - ProxSense® Series

## Table of Contents

1	Introduction.....	1
2	Standalone/Data Streaming EV-Kit.....	1
3	Standalone Operation.....	2
3.1	Powering on the device .....	2
3.2	Device operation .....	2
4	Data Streaming Operation .....	3
4.1	Overview of module boards .....	3
4.2	Setup for data streaming on computer.....	3
4.3	Using the GUI with the IQS227AS IC.....	4
4.4	Using the GUI with the IQS228AS IC.....	7
4.5	Configuring the IQS227AS and IQS228AS.....	8
5	Communications Interface .....	8
6	Reference Designs .....	8

## 1 Introduction

This user guide describes the operation of the IQS227-228ASEV02 Evaluation Kit. The EV-Kit consists of ten parts, the main board device, six separate plug-in module boards and three overlays. Additional unprogrammed IC's (3 x IQS227AS and 3 x IQS228AS) are included. To visualise raw data from the EV-Kit, the main board can be interfaced to any personal computer with USB support, and IQS227 or IQS228 software GUI (Graphical User Interface). The purpose of the IQS227-228ASEV02 EV-Kit is to help application and development engineers in evaluating the IQS227AS and IQS228AS proximity and touch sensor in self-capacitance mode.

## 2 Standalone/Data Streaming EV-Kit

Figure 2.1 illustrates the evaluation kit main board and a plug-in module board.

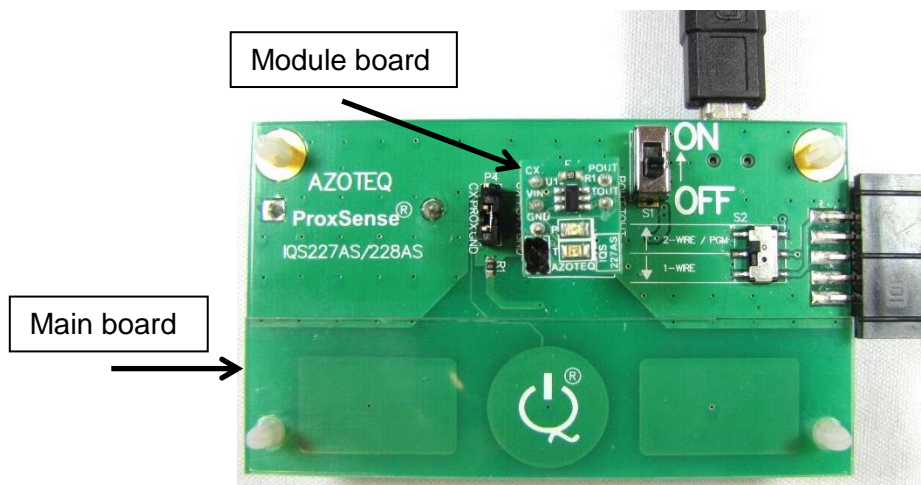

**Figure 2.1 IQS227AS/228AS main board with plugged in IQS227AS module board**



Simply plug in the desired module board and turn on the power switch.

Features included in the IQS227-228ASEV02:

- Modular design: Connect one of the supplied plug-in modules into the main board, to evaluate and compare proximity and touch performance.
- Reference designs for IQS227AS and IQS228AS with user proximity and touch detection.
- Used in Data Streaming Mode: EV-Kit requires Mini-USB cable with Azoteq CT2xx/DS1xx.

The EV-Kit main board can also draw power from a USB source by means of the mini-USB connector provided on the main board (optional).

### 3 Standalone Operation

#### 3.1 Powering on the device

In order to power the device, make sure the main board is set up as follow:

- Connect the IQS227AS (green board) plug-in module board.
- Put 1 overlay on the base board.
- Move the slide switch to the ON position.

Always switch OFF the device before making alterations to the main board. This is needed for the Integrated Circuit (IC) to adjust to the main board setup.

There are 3 alterations available:

- The plug-in module board can be exchanged for another board in the EV-Kit.
- The overlays can be added or removed as needed.
- The jumper can be shifted to connect the adjacent pads to the button.

After the device is powered through the ON/OFF slide switch, the device calibrates itself for the main board setup. This normally takes less than a second.

The placement of the jumper is very important and should by default connect the GND and PROX pins to add extra ground to the system. This is especially important when operating from a battery as the system does not have a very good ground reference and this will ensure correct operation. The jumper can also be shifted to connect the CX and PROX pins to increase the touch pad's size and reduce the ground in the system. This is advised against when running off batteries as the system's ground reference is too small to ensure correct operation and false Prox events will be triggered when touching the ground pour areas on the board.

#### 3.2 Device operation

After power ON, touch the button with a finger and 2 LED's should turn on as in Figure 3.1.



**Figure 3.1 Standalone activation**



The blue LED indicates a proximity event and the red LED a touch event. Evaluate the different module boards to observe the difference in sensitivity between them.

If the LED's do not turn on when touching the button, release the button or put the device on a table and try again.

## 4 Data Streaming Operation

The device can also be connected to a computer via the Azoteq CT2xx/DS1xx and the data streamed. The difference between the module boards will become clearly when visualised on a computer. A quick overview of the module boards will come next followed by the setup procedure for a computer and the GUI.

### 4.1 Overview of module boards

Table 1 gives a summary of the settings burned onto the IC's. The Green, Blue and Black refer to the different coloured module boards and the overlay refers to the thickness of the removable Perspex layers. A 3mm overlay is achievable by stacking three 1mm overlays on top of each other. The Target value is when the IC performs an Antenna Tuning Implementation (ATI) routine and adjusts the Compensation (Comp) and Sensitivity (Sense) multipliers for the Counts value to reach the Target value. The Touch Threshold (TTH) sets the point where a Touch event is triggered. This is calculated as a fraction of the current LTA value. For simplicity, an example of this calculation will be given.

Example:

With a TTH set to 48 and a Long Term Average (LTA) of 512, the equivalent  $\Delta$ Counts value is calculated as follow:

$$\Delta Counts = LTA \times \frac{TTH}{256} = 512 \times \frac{48}{256} = 96$$

This means that when the Counts value is  $\Delta$ Counts below the LTA, the Touch event will be triggered.

**Table 1: Settings for the module boards**

IC	Module Board	Overlay	Target	TTH	Multiplier Compensation	Multiplier Sensitivity
<b>IQS227AS</b>	Green	1mm	512	48	13	2
	Blue	2mm	1024	48	14	2
	Black	3mm	1024	24	Full ATI	
<b>IQS228AS</b>	Green	1mm	1024	72	13	2
	Blue	2mm	1200	72	7	2
	Black	3mm	1200	24	Full ATI	

### 4.2 Setup for data streaming on computer

To stream the data on a computer, the following will be needed besides the IQS227AS/228AS base board and various module boards:

- CT2xx/DS1xx (Available from Azoteq)
- Ribbon cable (Comes with the CT2xx/DS1xx)
- Micro USB cable to connect CT2xx/DS1xx to a computer (Comes with the CT2xx/DS1xx)
- IQS227 GUI and IQS228 GUI available at [www.azoteq.com/proximity-switches-design/capacitance-sensor-software-and-tools](http://www.azoteq.com/proximity-switches-design/capacitance-sensor-software-and-tools)

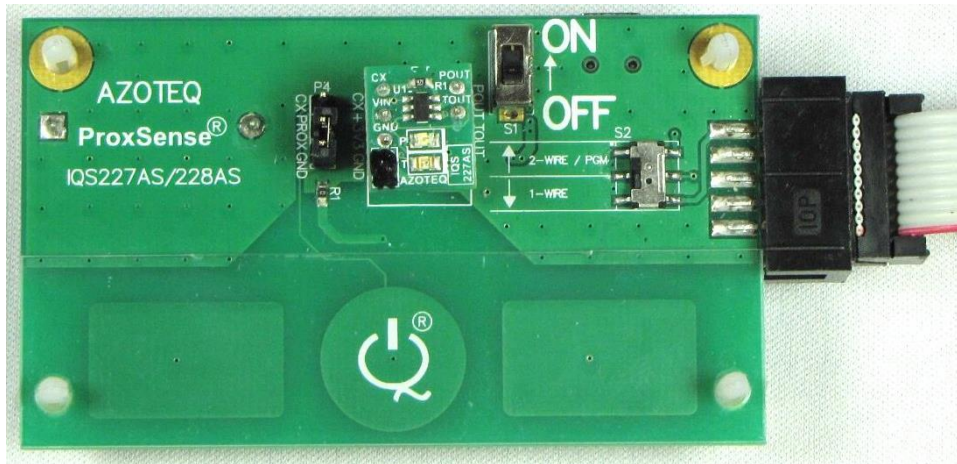

Figure 4.1 Setup for data streaming

Setup the base board connection with a computer by doing the following:

- Connect the CT2xx/DS1xx to a computer via a mini USB cable
- Connect the base board to the CT2xx/DS1xx
- Insert a module board onto the main board
- Make sure the slide switch is in the OFF position, the board will run on power from the CT2xx/DS1xx and not on batteries
- Install the IQS227 and IQS228 GUI on a computer
- Run the application “Azoteq IQS227.exe”

### 4.3 Using the GUI with the IQS227AS IC

When all of this is done correctly, your screen should look like in Figure 4.2. A small popup Hints & Tips window also appears which must be read and closed. The important parts to get started with the GUI are also circled. (We use IQS227 GUI Version 1.0.1.26 in this document and we also encourage our customers to use the latest versions available.)

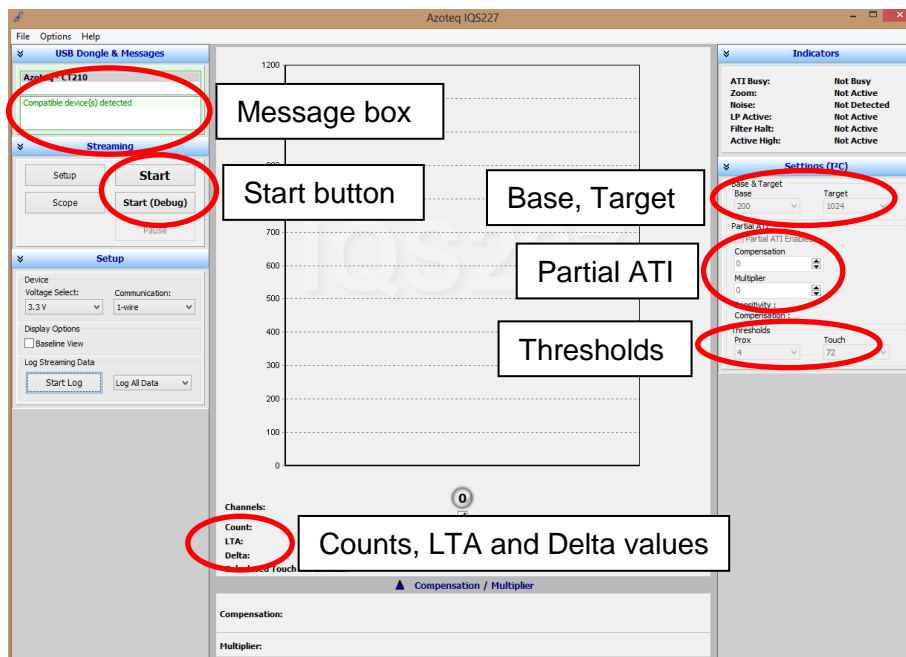

Figure 4.2 IQS227 GUI Start-up Screen

In the Message box, “Compatible device(s) detected” should be displayed. If the message “No compatible device(s) connected!” is displayed, there is a connection problem between the



computer and the CT2xx/DS1xx. Make sure the CT2xx/DS1xx is plugged in and or try a different USB port.

Before the device can start streaming data, make sure the base board is setup correctly.

- Move the ON/OFF slide switch to the OFF position
- Move the 2-wire/1-wire slide switch to the 2-wire position
- Make sure the ribbon cable is properly connected, the message “Device did not enter debug mode” will be displayed in the Message box if there is a problem with the ribbon cable connection

Click the **Start (Debug)** button to stream data. All the module boards included are default in standalone mode. The boards can be programmed to Enable Streaming (use the Start button), but then cannot be changed back to Standalone mode. If you click the Start button, you will receive a “Timeout during operation” error in the Message box.

When everything is setup correctly and working in the data streaming mode, the GUI should look similar to Figure 4.3. The Message box now displays “Device streaming started”. The LED’s on the module board will also turn on, this is not an error. In standalone mode the POUT and TOUT pins of the IC are connected to the 2 LED’s. In streaming mode the POUT and TOUT pins are used for the I<sup>2</sup>C communications and thus the 2 LED’s appear to be constantly on. There will also appear 2 grey bars in the GUI. The left one represents the Counts value and the right one the LTA value.

Under the Settings (I<sup>2</sup>C) menu is some settings that can be changed. For the Green and Blue module boards “Partial ATI Enabled” will be ticked and for the Black board it will not be ticked as default. During ATI, the internal circuitry will try to get the Count value as close as possible to the Target value by adjusting the Compensation and Multiplier fields. The Multiplier field acts as a course adjustment to the Count value and the Compensation field acts as a fine adjustment.

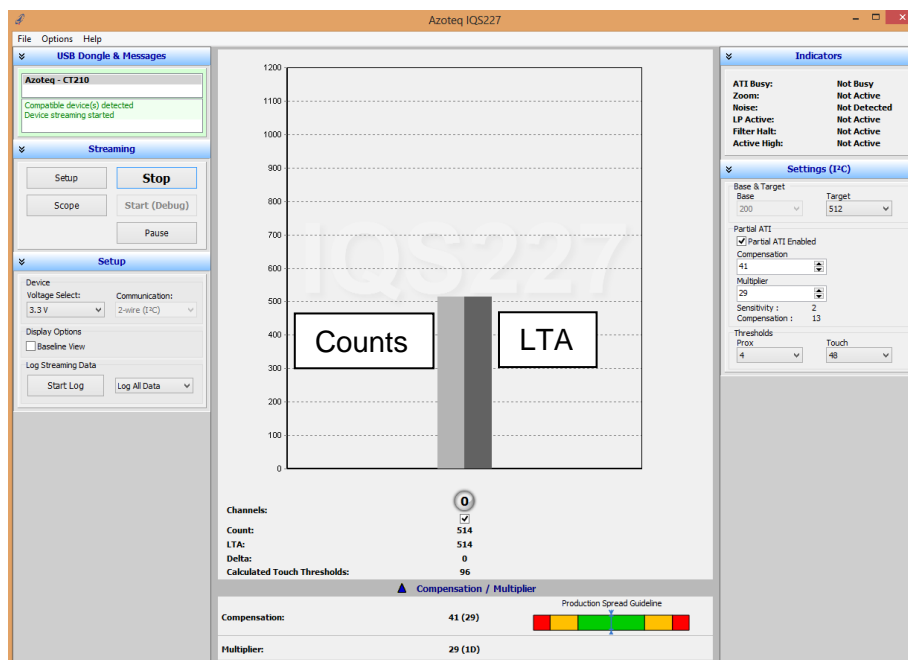

**Figure 4.3 Successful Streaming**

Start off by choosing suitable Prox and Touch values. The Prox value determines the Delta at which a proximity event is triggered and the Touch value a touch event as described earlier. With “Partial ATI Enabled” ticked, the user has 2 values to pick, namely: Target and Multiplier. Although Compensation can also be adjusted, it is advised not to change this as the IC chooses this value automatically. Every time the Counts value rise to outside a certain level above the LTA, the IC adjusts the Compensation for the Counts to be as close as possible to the Target value.



With “Partial ATI Enabled” not ticked, the Base value option becomes available. By choosing a certain Base value, the IC will automatically pick the Multiplier and Compensation values for the Count value to reach the Target. If a lower Base value is picked, the IC might enter a Touch event and seem like it got stuck. One way to get out of this stuck condition is to wait for the Time-Out timer to complete and re-ATI the IC. The default Time-Out time is 18s.

An important consideration is the “Production Spread Guideline” bar located at the bottom of the window. The IC chooses the Compensation value in order to get as close as possible to the Target value. The Compensation value can range from 0 to 255 and must preferably not be too low or too high. The Multiplier and Compensation values will most likely be application specific, but it is advised to aim for a Compensation value of between 30 and 210.

Another important issue is the Prox and Touch threshold. Ensure that the Prox threshold is always lower than the calculated Touch threshold. This is needed for device stability as the LTA filter only halts when it sees a Prox and then a Touch event. If it sees a Touch event first without the Prox event, the LTA filter halt might not enable and the LTA will follow the Counts.

All the settings should now be setup correctly. When a finger comes close to the button, the device will enter Prox mode. Figure 4.4 shows what a typical Prox event should look like. Note that the Counts and LTA bars have turned blue to indicate a Prox event and the Filter Halt is Active in the Indicators menu.

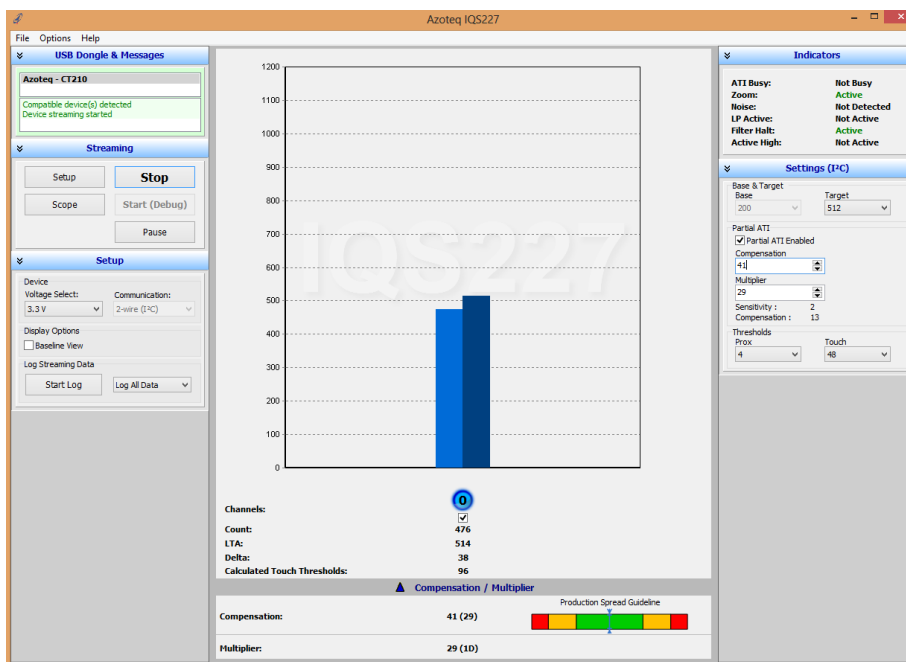

**Figure 4.4 IQS227AS Proximity Event**

When a finger comes closer and touches the button, a Touch event will be triggered. Figure 4.5 shows what a typical Touch event should look like. Note that the Counts and LTA bars have turned red to indicate a Touch event and the Filter Halt is still Active.

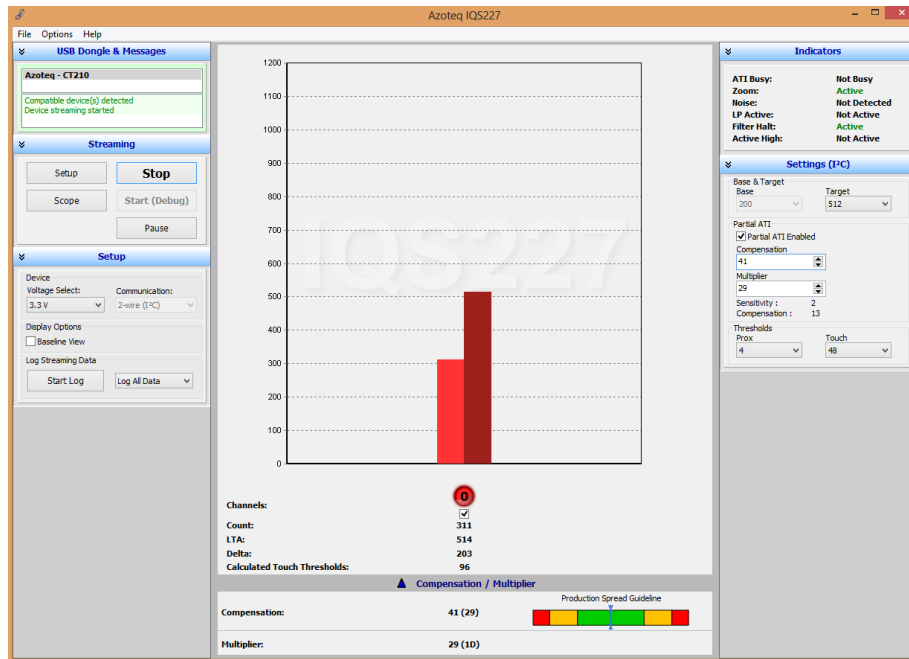

Figure 4.5 IQS227AS Touch Event

The various IQS227AS module boards can now be evaluated to observe the different obtainable sensitivities for a wide range of applications.

#### 4.4 Using the GUI with the IQS228AS IC

The IQS228AS IC operates similarly to the IQS227AS IC when in Prox mode, but differently when in Touch mode. Place the IQS228AS Green module board in the socket and evaluate the board. The Prox event is very similar to Figure 4.4, but the Touch event is different and shown below in Figure 4.6.

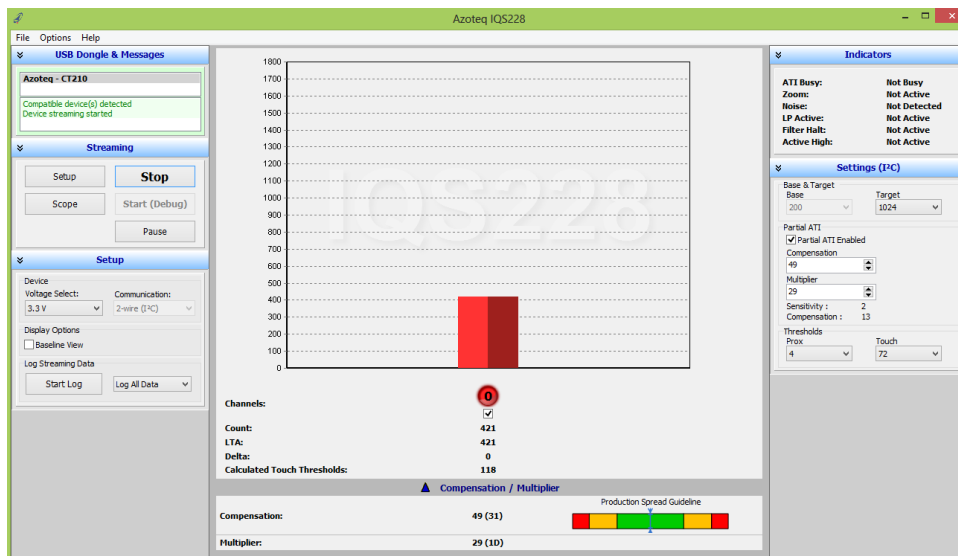

Figure 4.6 IQS228AS Touch Event

The IQS228AS IC has a DYCAL (Dynamic Calibration) function which works well for long Touch events. When in Prox mode, the Filter Halt is active and the LTA does not follow the Counts. When the device enters Touch mode, the Filter Halt is deactivated and the LTA now follow the Counts. This is needed as during long Touch events the environment can change and the device



compensates for these slow varying changes. The device exits the Touch event when the Counts value rise a certain amount above the LTA and is then ready for another touch.

The various settings can also be changed as with the IQS227 GUI. Evaluate the Green, Blue and Black module boards to observe the different sensitivity levels obtainable.

#### 4.5 Configuring the IQS227AS and IQS228AS

Use the USBProg program, available from the Azoteq website, to burn fuses on the IQS227AS IC or IQS228AS IC. Consult the IQS227AS and IQS228AS datasheets for more information available on the Azoteq website.

### 5 Communications Interface

The IQS227AS and IQS228AS IC's communicate according to the I<sup>2</sup>C communication protocol. More on this can be obtained from Application Note 25 (AZD025), available from the Azoteq website.

### 6 Reference Designs

Figure 6.1 and Figure 6.2 shows reference designs for the main board and the module boards.

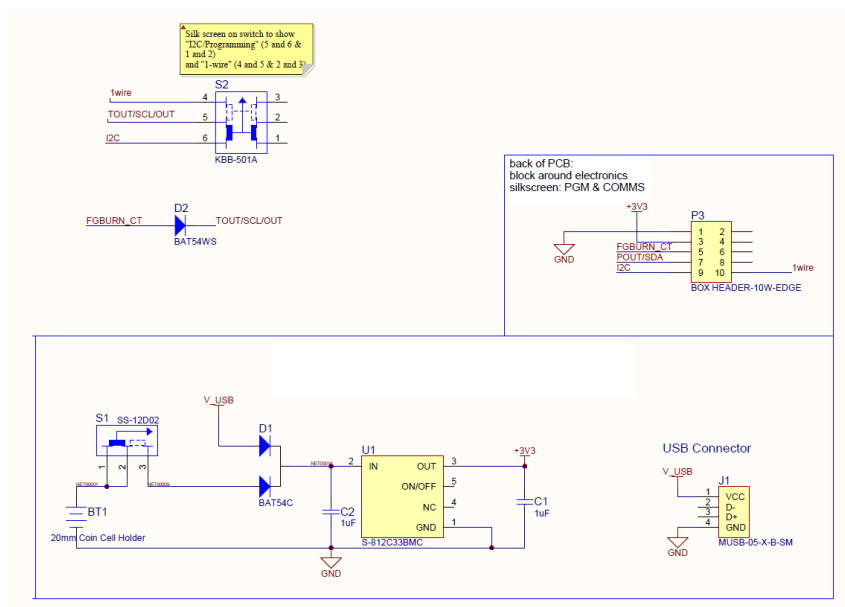

Figure 6.1 IQS227-228ASEV02 Main board design



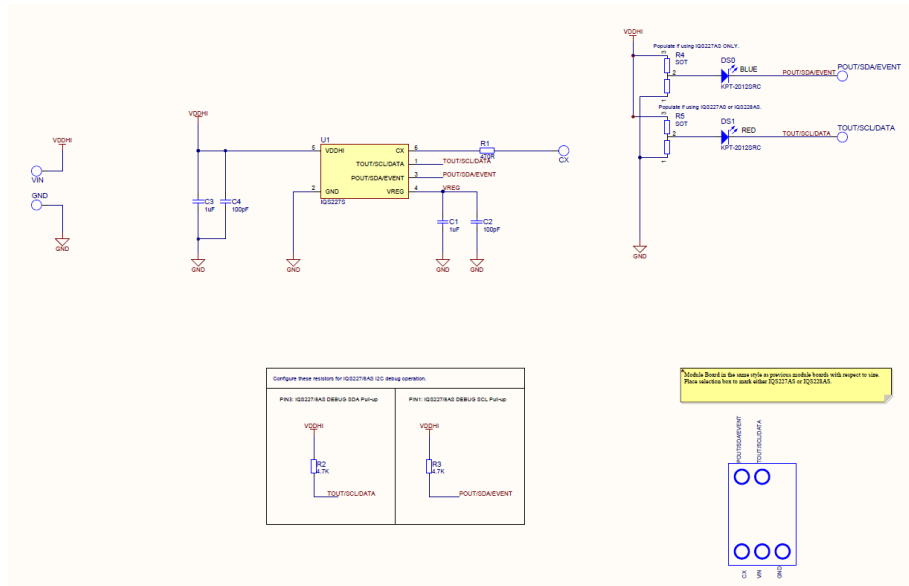

Figure 6.2 IQS227-228ASEV02 Module board design



## Appendix A Contact Information

	USA	Asia	South Africa
<b>Physical Address</b>	6507 Jester Blvd Bldg 5, suite 510G Austin TX 78750 USA	Rm1725, Glittery City Shennan Rd Futian District Shenzhen, 518033 China	109 Main Street Paarl 7646 South Africa
<b>Postal Address</b>	6507 Jester Blvd Bldg 5, suite 510G Austin TX 78750 USA	Rm1725, Glittery City Shennan Rd Futian District Shenzhen, 518033 China	PO Box 3534 Paarl 7620 South Africa
<b>Tel</b>	+1 512 538 1995	+86 755 8303 5294 ext 808	+27 21 863 0033
<b>Fax</b>	+1 512 672 8442		+27 21 863 1512
<b>Email</b>	<a href="mailto:kobusm@azoteq.com">kobusm@azoteq.com</a>	<a href="mailto:linayu@azoteq.com.cn">linayu@azoteq.com.cn</a>	<a href="mailto:info@azoteq.com">info@azoteq.com</a>

Please visit [www.azoteq.com](http://www.azoteq.com) for a list of distributors and worldwide representation.

The following patents relate to the device or usage of the device: US 6,249,089 B1, US 6,621,225 B2, US 6,650,066 B2, US 6,952,084 B2, US 6,984,900 B1, US 7,084,526 B2, US 7,084,531 B2, US 7,265,494 B2, US 7,291,940 B2, US 7,329,970 B2, US 7,336,037 B2, US 7,443,101 B2, US 7,466,040 B2, US 7,498,749 B2, US 7,528,508 B2, US 7,755,219 B2, US 7,772,781, US 7,781,980 B2, US 7,915,765 B2, US 7,994,726 B2, US 8,035,623 B2, US 8,288,952 B2, EP 1 120 018 B1, EP 1 206 168 B1, EP 1 308 913 B1, EP 1 530 178 B1, ZL 200880005683.2, ZL 99 8 14357.X, AUS 761094, HK 104 14100A

IQ Switch®, SwipeSwitch™, ProxSense®, LightSense™, AirButton® and the  logo are trademarks of Azoteq.

The information in this Datasheet is believed to be accurate at the time of publication. Azoteq uses reasonable effort to maintain the information up-to-date and accurate, but does not warrant the accuracy, completeness or reliability of the information contained herein. All content and information are provided on a "as is" basis only, without any representations or warranties, express or implied, of any kind, including representations about the suitability of these products or information for any purpose. Azoteq disclaims all warranties and conditions with regard to these products and information, including but not limited to all implied warranties and conditions of merchantability, fitness for a particular purpose, title and non-infringement of any third party intellectual property rights. Azoteq assumes no liability for any damages or injury arising from any use of the information or the product or caused by, without limitation, failure of performance, error, omission, interruption, defect, delay in operation or transmission, even if Azoteq has been advised of the possibility of such damages. The applications mentioned herein are used solely for the purpose of illustration and Azoteq makes no warranty or representation that such applications will be suitable without further modification, nor recommends the use of its products for application that may present a risk to human life due to malfunction or otherwise. Azoteq products are not authorized for use as critical components in life support devices or systems. No licenses to patents are granted, implicitly, express or implied, by estoppel or otherwise, under any intellectual property rights. In the event that any of the abovementioned limitations or exclusions does not apply, it is agreed that Azoteq's total liability for all losses, damages and causes of action (in contract, tort (including without limitation, negligence) or otherwise) will not exceed the amount already paid by the customer for the products. Azoteq reserves the right to alter its products, to make corrections, deletions, modifications, enhancements, improvements and other changes to the content and information, its products, programs and services at any time or to move or discontinue any contents, products, programs or services without prior notification. For the most up-to-date information and binding Terms and Conditions please refer to [www.azoteq.com](http://www.azoteq.com).

[WWW.AZOTEQ.COM](http://WWW.AZOTEQ.COM)  
[info@azoteq.com](mailto:info@azoteq.com)

# Mouser Electronics

Authorized Distributor

Click to View Pricing, Inventory, Delivery & Lifecycle Information:

[Azoteq:](#)

[IQS227/228ASEV02](#)