

REVISIONS			
REV	DESCRIPTION	DATE	APPROVED
01 ₀	RELEASED		
01 ₁	SEE ECN 92-0010	10/30/92	<i>M.M.</i> 11/4/92

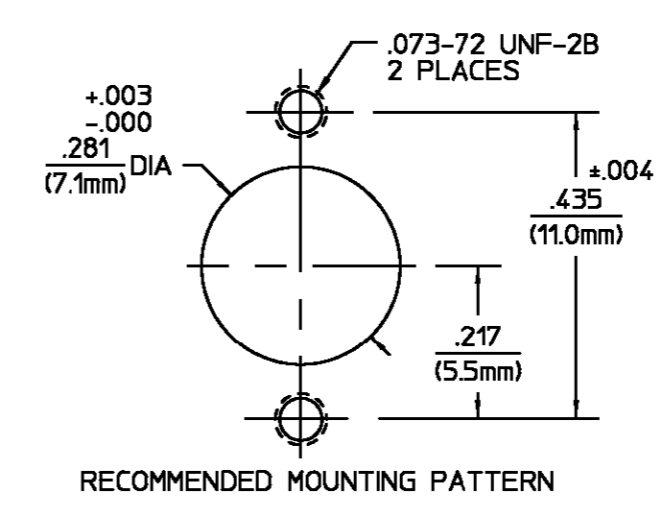

$.093$ (2.4mm) DIA
2 HOLES

HOUSING FLAT WASHER	STAINLESS STEEL PER ASTM-A484 AND ASTM- A582, TYPE 303	PASSIVATE PER ASTM-A380
DIELECTRIC	TFE FLUOROCARBON PER ASTM-D-1457	N/A
CENTER CONTACT CONTACT SLEEVE	BERYLLIUM COPPER PER ASTM B 196, ALLOY C17300, CONDITION H	GOLD PLATE PER MIL-G-45204 OVER COPPER PLATE PER MIL-C-14550
SPRING	STAINLESS STEEL	PASSIVATED
CONTACT RING	BERYLLIUM COPPER PER ASTM B 194, ALLOY C17200, CONDITION H	GOLD PLATE PER MIL-G-45204

COMPONENT	MATERIAL	FINISH
-----------	----------	--------

UNLESS OTHERWISE SPECIFIED DIMENSIONS ARE IN INCHES TOLERANCE ON FRAC. DEC. ANGLES $\pm 1/64$ $\pm .005$ $\pm 1^\circ$	DRAWN BY S. R. BROWN	DATE 3/10/88	AMP Incorporated 140 Fourth Avenue Waltham, MA 02451-7599
	CHECKED BY T. A. S.	4/18/88	
	APPROVED BY B. CLEVELAND	6/14/88	

These drawings and specifications are the property of Omni Spectra Incorporated and shall not be reproduced or copied or used in whole or in part as the basis for the manufacture or sale of item(s) without written permission.	USE ASS'Y PROCEDURE	TITLE OSM JACK TO OSSP JACK FLOAT MOUNT ADAPTER	
	NO. AP. <u>N/A</u>	SIZE B	CODE IDENT NO. 4784-2242-02
		SCALE 4:1	REV 01 ₁

Mouser Electronics

Authorized Distributor

Click to View Pricing, Inventory, Delivery & Lifecycle Information:

[TE Connectivity:](#)

[1059825-1](#)