

THIS DRAWING IS UNPUBLISHED. RELEASED FOR PUBLICATION  
 © COPYRIGHT - By - ALL RIGHTS RESERVED.

LOC	DIST	REVISIONS			
P	LTR	DESCRIPTION	DATE	DWN	APVD
FT	47	AG1	REVISED PER ECO-15-003583	07MAR2015	NK MZ

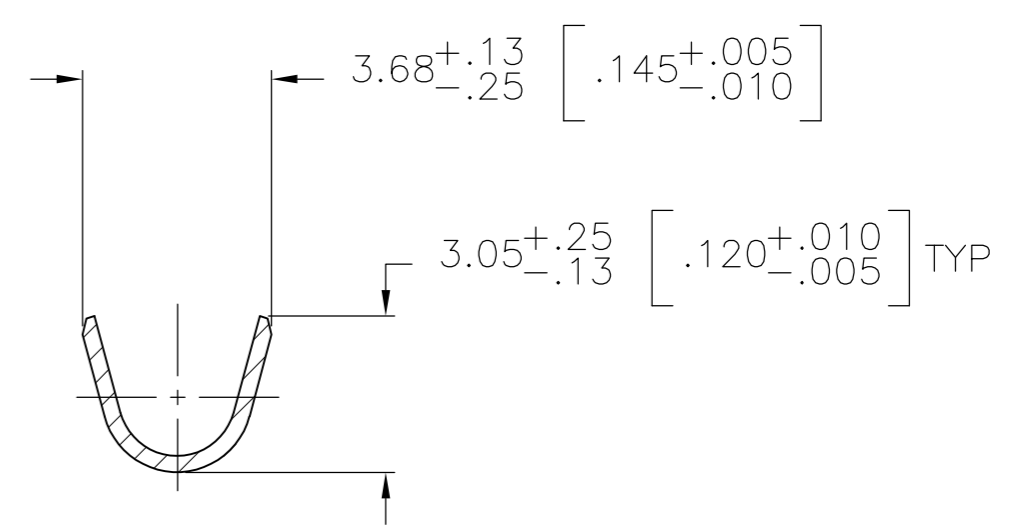

SECTION A-A

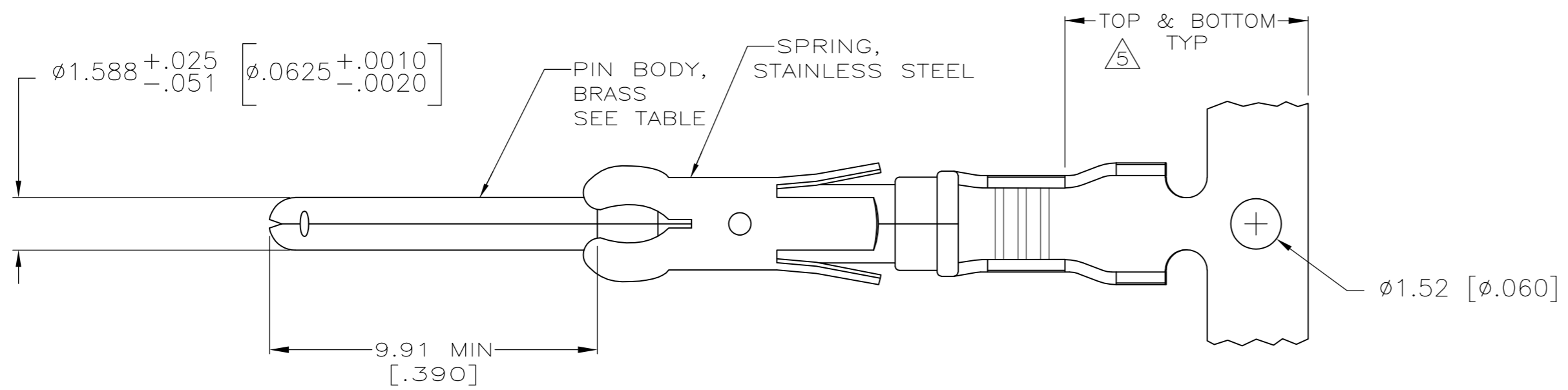
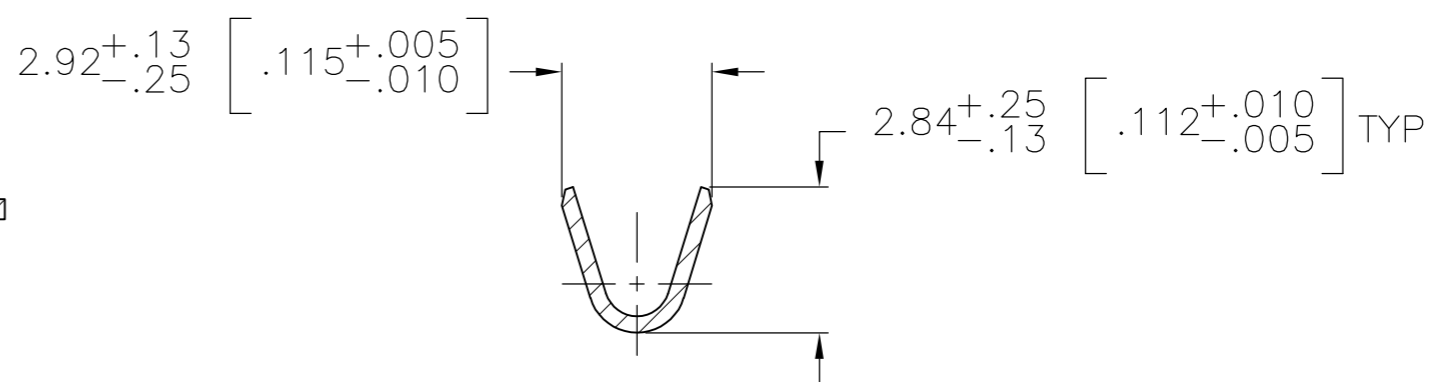
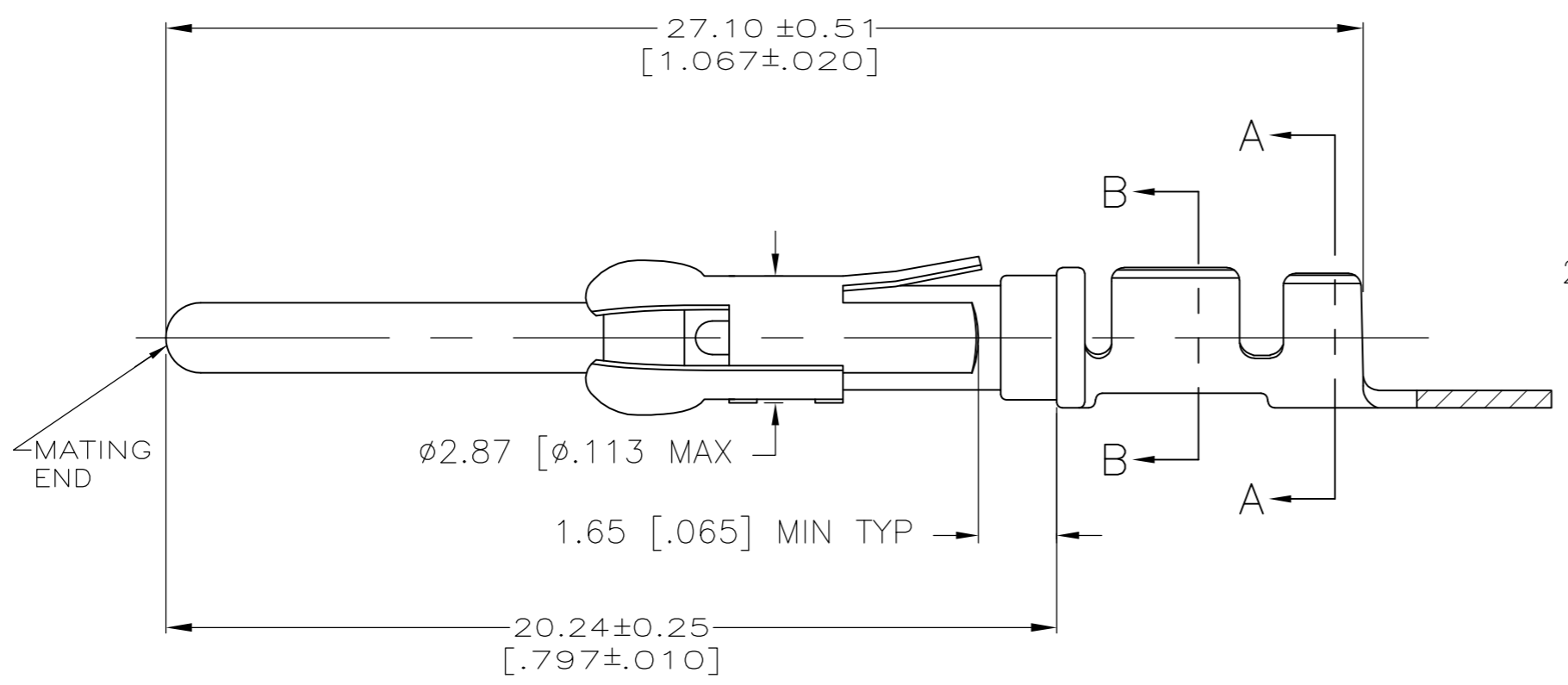

SECTION B-B

- 1 REVERSE REELED FOR MINI-APPLICATOR.
- 2  $0.76\mu\text{m}$  [.000030] MIN PRECIOUS METAL PLATE ON MATING END FOR A LENGTH OF 5.08 [.200] MIN WITH  $1.27\mu\text{m}$  [.000050] MIN MATTE TIN PLATE IN WIRE CRIMP AREA, BOTH OVER  $1.27\mu\text{m}$  [.000050] MIN NICKEL PLATE. CONFORMS TO THE REQUIREMENTS OF TE PRODUCT SPEC 108-10042, BASED ON EIA/ECA-364-1000.01A (CONTROLLED ENVIRONMENT APPLICATIONS).
- 3  $0.76\mu\text{m}$  [.000030] MIN PRECIOUS METAL PLATE ON MATING END FOR A LENGTH OF 5.08 [.200] MIN WITH A UNIFORM GRADIENT TO  $0.25\mu\text{m}$  [.000010] ON REMAINDER, OVER  $1.27\mu\text{m}$  [.000050] MIN NICKEL PLATE. GOLD FLASH ALL OVER. CONFORMS TO THE REQUIREMENTS OF TE PRODUCT SPEC 108-10042, BASED ON EIA/ECA-364-1000.01A (CONTROLLED ENVIRONMENT APPLICATIONS).
- 4  $0.38\mu\text{m}$  [.000015] MIN GOLD PER MIL-G-45204 ON MATING END FOR A LENGTH OF 5.08 [.200] MIN WITH  $1.27\mu\text{m}$  [.000050] MIN MATTE TIN PLATE IN WIRE CRIMP AREA, BOTH OVER  $1.27\mu\text{m}$  [.000050] MIN NICKEL PER QQ-N-290.
- 5 GOLD PLATING NEED NOT APPEAR IN THIS AREA.
- 6  $1.27\mu\text{m}$  [.000050] MIN TIN-LEAD PER MIL-T-10727 OVER  $1.27\mu\text{m}$  [.000050] MIN NICKEL PER QQ-N-290.
- 7 ALL PART NUMBERS ON THIS DRAWING HAVE APPLICATION TOOLING AVAILABLE TO CRIMP TO 18-16 AWG WIRE WITH AN INSULATION RANGE OF  $\phi 2.03-2.54$  [.080-.100] ADDITIONALLY, LOOSE PIECE AND REVERSE REELED PART NUMBERS HAVE APPLICATION TOOLING AVAILABLE TO CRIMP  $0.75\text{mm}^2$  WIRE WITH AN INSULATION RANGE OF  $\phi 1.35-1.65$  [.053-.065] OR  $1.0\text{mm}^2$  WIRE WITH AN INSULATION RANGE OF  $\phi 1.45-1.80$  [.057-.071].
- 8  $0.38\mu\text{m}$  [.000015] MIN GOLD PER MIL-G-45204 ON MATING END FOR A LENGTH OF 5.08 [.200] MIN,  $1.27\mu\text{m}$  [.000050] MIN TIN-LEAD PER MIL-T-10727 ON OPPOSITE END FOR A LENGTH OF 5.69 [.224] MIN, BOTH OVER  $1.27\mu\text{m}$  [.000050] MIN NICKEL PER QQ-N-290.
- 9  $1.27\mu\text{m}$  [.000050] MIN TIN PER MIL-T-10727 OVER  $1.27\mu\text{m}$  [.000050] MIN NICKEL PER QQ-N-290.

SUPERCEDED BY 66098-8

STANDARD	9	1-66099-5	1-66098-9
1	9	1-66099-5	1-66098-8
1	8	1-66099-0	1-66098-6
1	2	66099-4	66098-9
1	4	66099-3	66098-8
1	6	66099-2	66098-7
1	3	66099-1	66098-6
STANDARD	2	66099-4	66098-4
STANDARD	4	66099-3	66098-3
STANDARD	6	66099-2	66098-2
STANDARD	3	66099-1	66098-1
REELING	PIN BODY FINISH	LOOSE PIECE REF	PART NUMBER

THIS DRAWING IS A CONTROLLED DOCUMENT.

DWN V. FURLER 19JUN2003  
 CHK G. STEINHAUER 19JUN03  
 APVD G. STEINHAUER 19JUN03

**STE** TE Connectivity

PIN ASSEMBLY, .062, TYPE III+

SIZE A2 CAGE CODE 00779 DRAWING NO. C=66098 RESTRICTED TO

MATERIAL SEE CALLOUTS FINISH SEE TABLE WEIGHT - SCALE 1:1 SHEET 1 OF 1 REV AG1

CUSTOMER DRAWING

# Mouser Electronics

Authorized Distributor

Click to View Pricing, Inventory, Delivery & Lifecycle Information:

[TE Connectivity:](#)

[66098-9](#)