

SPECIFICATION CONTROL DRAWING

82A0811

| | | | | | |
|-------|---|------|---------|----------|---|
| TITLE | WIRE, RADIATION-CROSSLINKED, MODIFIED FLEXIBLE ETFE-INSULATED, NORMAL WEIGHT, GENERAL PURPOSE, 600 VOLT | Date | 11-5-13 | Revision | F |
|-------|---|------|---------|----------|---|

This specification sheet forms a part of the latest issue of Raychem Specification 80.

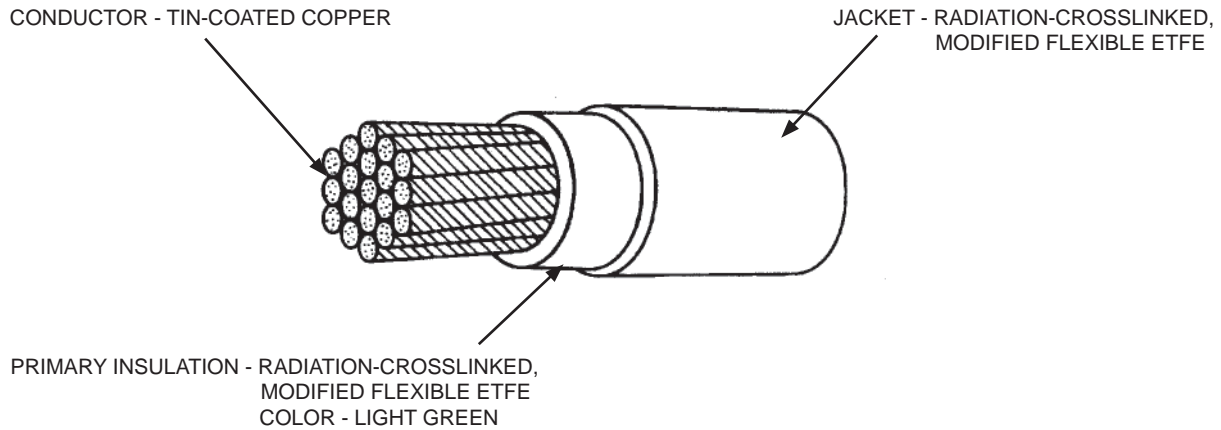



TABLE I. CONSTRUCTION DETAILS

| PART NUMBER 1/ | WIRE SIZE (AWG) | CONDUCTOR STRANDING (number x AWG) | DIAMETER OF STRANDED CONDUCTOR (inch) | | FINISHED WIRE | | |
|-------------------|--------------------|---------------------------------------|--|---------|---|-----------------|-------------------------------|
| | | | MINIMUM | MAXIMUM | MAXIMUM RESISTANCE AT 20°C (ohms/1000 ft.) | DIAMETER (inch) | MAXIMUM WEIGHT (lbs/1000 ft.) |
| | | | | | | | |
| 82A0811-24-* | 24 | 105 x 44 | .023 | .027 | 28.2 | .044 ± .003 | 2.5 |
| 82A0811-22-* | 22 | 154 x 44 | .029 | .033 | 19.2 | .054 ± .003 | 3.7 |
| 82A0811-20-* | 20 | 154 x 42 | .037 | .043 | 11.7 | .064 ± .004 | 5.2 |
| 82A0811-18-* | 18 | 259 x 42 | .047 | .053 | 7.14 | .076 ± .004 | 8.0 |
| 82A0811-16-* | 16 | 259 x 40 | .061 | .067 | 4.53 | .092 ± .005 | 11.9 |
| 82A0811-14-* | 14 | 665 x 42 | .078 | .086 | 2.96 | .116 ± .005 | 19.3 |
| 82A0811-12-* | 12 | 665 x 40 | .096 | .106 | 1.89 | .137 ± .006 | 27.9 |
| 82A0811-10-* | 10 | 665 x 38 | .126 | .140 | 1.12 | .187 ± .008 | 50.0 |
| 82A0811-8-* | 8 | 665 x 36 | .157 | .173 | .714 | .230 ± .008 | 77.3 |
| 82A0811-6-* | 6 | 1045 x 36 | .192 | .208 | .490 | .277 ± .010 | 118. |
| 82A0811-4-* | 4 | 1665 x 36 | .265 | .285 | .326 | .359 ± .010 | 189. |
| 82A0811-2-* | 2 | 1665 x 34 | .325 | .345 | .204 | .433 ± .016 | 282. |
| 82A0811-1-* | 1 | 2109 x 34 | .370 | .400 | .163 | .488 ± .016 | 348. |
| 82A0811-0-* | 0 | 2660 x 34 | .435 | .465 | .133 | .558 ± .016 | 442. |
| 82A0811-00-* | 00 | 3325 x 34 | .485 | .515 | .102 | .612 ± .016 | 544. |
| 82A0811-000-* | 000 | 4123 x 34 | .540 | .575 | .087 | .678 ± .016 | 668. |
| 82A0811-0000-* | 0000 | 5320 x 34 | .615 | .655 | .066 | .771 ± .022 | 863. |

Users should evaluate the suitability of this product for their application. Specifications are subject to change without notice. Tyco Electronics Corporation also reserves the right to make changes in materials or processing, which do not affect compliance with any specification, without notification to Buyer.

1/ COLORS AND COLOR CODE DESIGNATORS SHALL BE IN ACCORDANCE WITH MIL-STD-681. OTHER CODES AND SUFFIXES MAY BE ADDED TO THE PART NUMBER, AS NECESSARY, TO CAPTURE ANY ADDITIONAL REQUIREMENTS IMPOSED BY THE PURCHASE ORDER.

| | | | |
|-------------|---|---|---|
| Page 1 of 2 | Raychem, TE Connectivity, TE connectivity (logo), and TE (logo) are trademarks. |  | Raychem Wire & Cable 501 Oakside Avenue Redwood City, CA 94063-3800 Phone: 1-800-227-8816 Fax: 1-650-361-6297 |
| | DIMENSIONS ARE IN INCHES AND, UNLESS OTHERWISE DESIGNATED, ARE NOMINAL. | | |
| | THIS SPECIFICATION SHEET TAKES PRECEDENCE OVER DOCUMENTS REFERENCED HEREIN. REFERENCED DOCUMENTS SHALL BE OF THE ISSUE IN EFFECT ON DATE OF INVITATION FOR BID. | | |



SPECIFICATION CONTROL DRAWING

82A0811

Page

2 of 2

Revision

F

TABLE II. PERFORMANCE DETAILS

| PART NUMBER 1/ | BEND TESTING | |
|-------------------|-----------------------------------|-------------------------|
| | MANDREL DIAMETER (inch) (± 3%) | WEIGHT (lbs) (± 3%) |
| | CROSSLINKING PROOF TEST | CROSSLINKING PROOF TEST |
| 82A0811-24-* | .500 | .750 |
| 82A0811-22-* | .500 | 1.00 |
| 82A0811-20-* | .500 | 1.50 |
| 82A0811-18-* | .750 | 2.00 |
| 82A0811-16-* | 1.00 | 2.00 |
| 82A0811-14-* | 1.00 | 3.00 |
| 82A0811-12-* | 1.50 | 3.00 |
| 82A0811-10-* | 2.00 | 3.00 |
| 82A0811-8-* | 3.00 | 4.00 |
| 82A0811-6-* | 4.00 | 4.00 |
| 82A0811-4-* | 5.00 | 4.00 |
| 82A0811-2-* | 6.00 | 6.00 |
| 82A0811-1-* | 8.00 | 6.00 |
| 82A0811-0-* | 8.00 | 6.00 |
| 82A0811-00-* | 10.0 | 8.00 |
| 82A0811-000-* | 10.0 | 8.00 |
| 82A0811-0000-* | 10.0 | 8.00 |

WIRE RATINGS AND ADDITIONAL REQUIREMENTS

TEMPERATURE RATING: 150°C

Maximum continuous conductor temperature
VOLTAGE RATING: 600 volts (rms) at sea level

CONCENTRICITY: 70% (minimum)

CROSSLINKING PROOF TEST: 300 ± 3°C for 7 hours

IDENTIFICATION AND COLOR STRIPING DURABILITY:

125 cycles (250 strokes) (minimum), 500 g weight

INSULATION ELONGATION AND TENSILE STRENGTH:

AWG 24-10: Elongation, 75% (minimum)
Tensile Strength, 3500 lbf/in² (minimum)

AWG 8-0000: Elongation, 125% (minimum)
Tensile Strength, 3000 lbf/in² (minimum)

INSULATION FLAWS:

Primary Insulation,

Spark Test, 1.5 kV (rms) at 3 kHz
Impulse Dielectric Test, 6.0 kV (peak)

Finished Wire,

Spark Test, 3.0 kV (rms) at 3 kHz
Impulse Dielectric Test, 8.0 kV (peak)

INSULATION THICKNESS:

AWG 24-18: .004 in. (minimum) for primary insulation
.004 in. (minimum) for outer jacket

AWG 16-10: .005 in. (minimum) for primary insulation
.005 in. (minimum) for outer jacket

AWG 8-4: .008 in. (minimum) for primary insulation
.012 in. (minimum) for outer jacket

AWG 2-0000: .010 in. (minimum) for primary insulation
.015 in. (minimum) for outer jacket

JACKET COLOR: White preferred

SECANT MODULUS (Test per ASTM D 882):

AWG 24-10: 5.0 x 10⁴ lbf/in² (maximum)

AWG 8-0000: 4.0 x 10⁴ lbf/in² (maximum)

2% strain, 2 inch jaw separation, 0.2 inch/minute

SHRINKAGE: 150 ± 3°C for 6 hours,

AWG 24-10: 0.13 in. (maximum) in 12 inches

AWG 8-0000: 0.25 in. (maximum) in 12 inches

VOLTAGE WITHSTAND (Post Environmental): 2500 volts (rms), 60 Hz

1/ PART NUMBER:

The “*” in the part numbers on pages 1 and 2 shall be replaced by a color code designator.

Example: AWG 12, white: 82A0811-12-9

AWG 12, white with a black stripe: 82A0811-12-90

1/ See footer section on page 1

Mouser Electronics

Authorized Distributor

Click to View Pricing, Inventory, Delivery & Lifecycle Information:

[TE Connectivity:](#)

[CA3527-000](#)