

REVISIONS				
P	LTN	DESCRIPTION	DATE	BY
1		DRAWN	7APR2017	BDY
A		RELEASED	13APR2017	BY

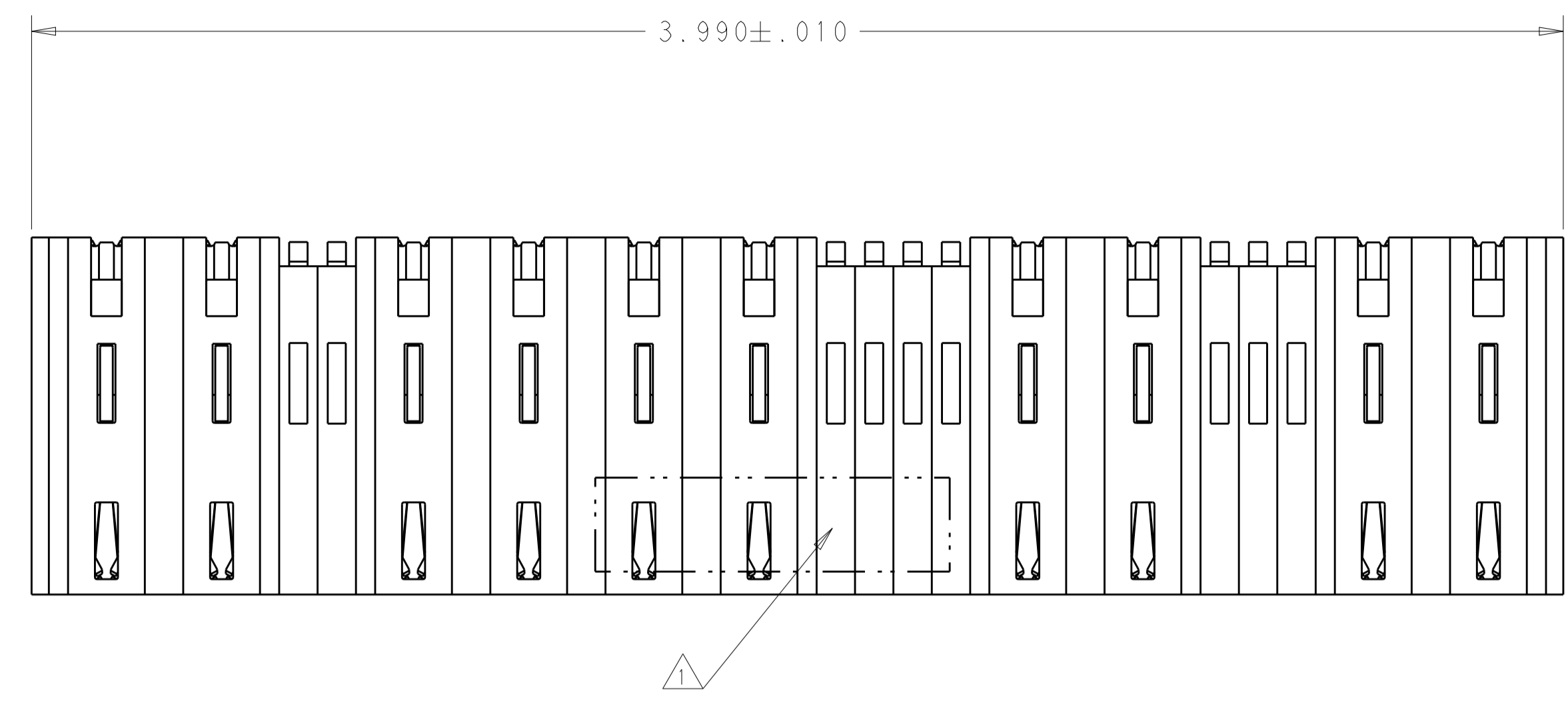

- ⚠ "TE", TE PART NUMBER, AND DATE CODE TO BE MARKED IN AREA SHOWN. PARTS UNDER 2.00 LONG MAY BE MARKED ON BOTH SIDES.
- ⚠ MATERIAL: HOUSING - GLASS FILLED HIGH TEMP THERMO PLASTIC, BLACK, UL94 V-0  
POWER CONTACT - HIGH CONDUCTIVITY COPPER ALLOY  
SIGNAL CONTACT - HIGH CONDUCTIVITY COPPER ALLOY  
LOW POWER CONTACT - HIGH CONDUCTIVITY COPPER ALLOY
- ⚠ CONTACT PLATING: SIGNAL CONTACTS - .000050 MIN Ni UNDER ALL  
.000050 MIN Au ON CONTACT AREA  
.000005 MIN Au AT PCB INTERFACE  
POWER CONTACTS - .000050 MIN Ni UNDER ALL  
.000050 MIN Au ON CONTACT AREA  
.000005 MIN Au AT PCB INTERFACE  
LOW POWER CONTACTS - .000050 MIN Ni UNDER ALL  
.000050 MIN Au ON CONTACT AREA  
.000005 MIN Au AT PCB INTERFACE
- ⚠ MECHANICAL CONNECTOR KEEP OUT ZONE.
- ⚠ DATUM AND BASIC DIMENSIONS ESTABLISHED BY CUSTOMER.
- ⚠ PCB - HOLE DIAMETERS ARE FINISHED HOLE SIZE.
- ⚠ PCB - .0453 ± .0010 DRILLED HOLES PLATED WITH .0003 MIN Sn OVER .001 TO .003 Cu PLATING TO ACHIEVE A .040 DIA HOLE.

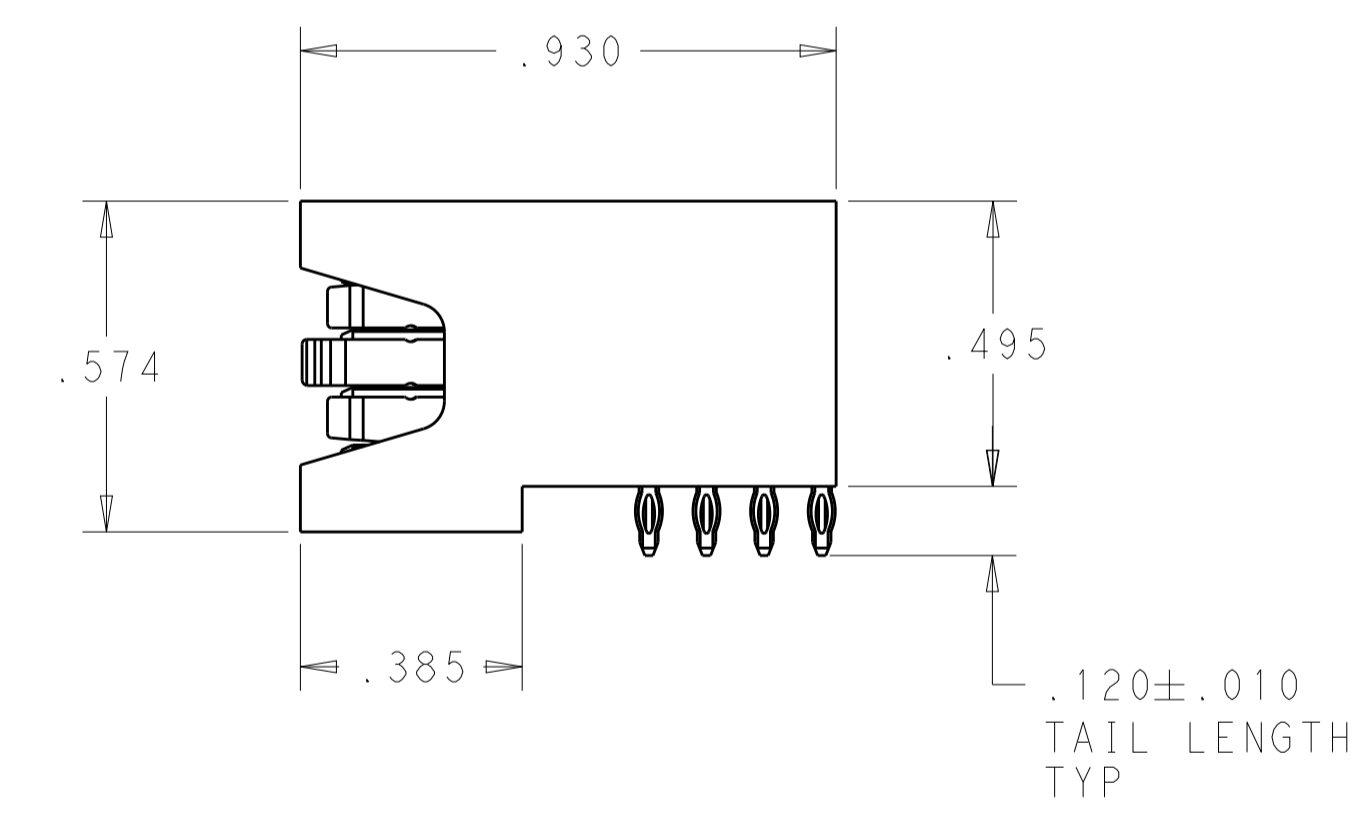
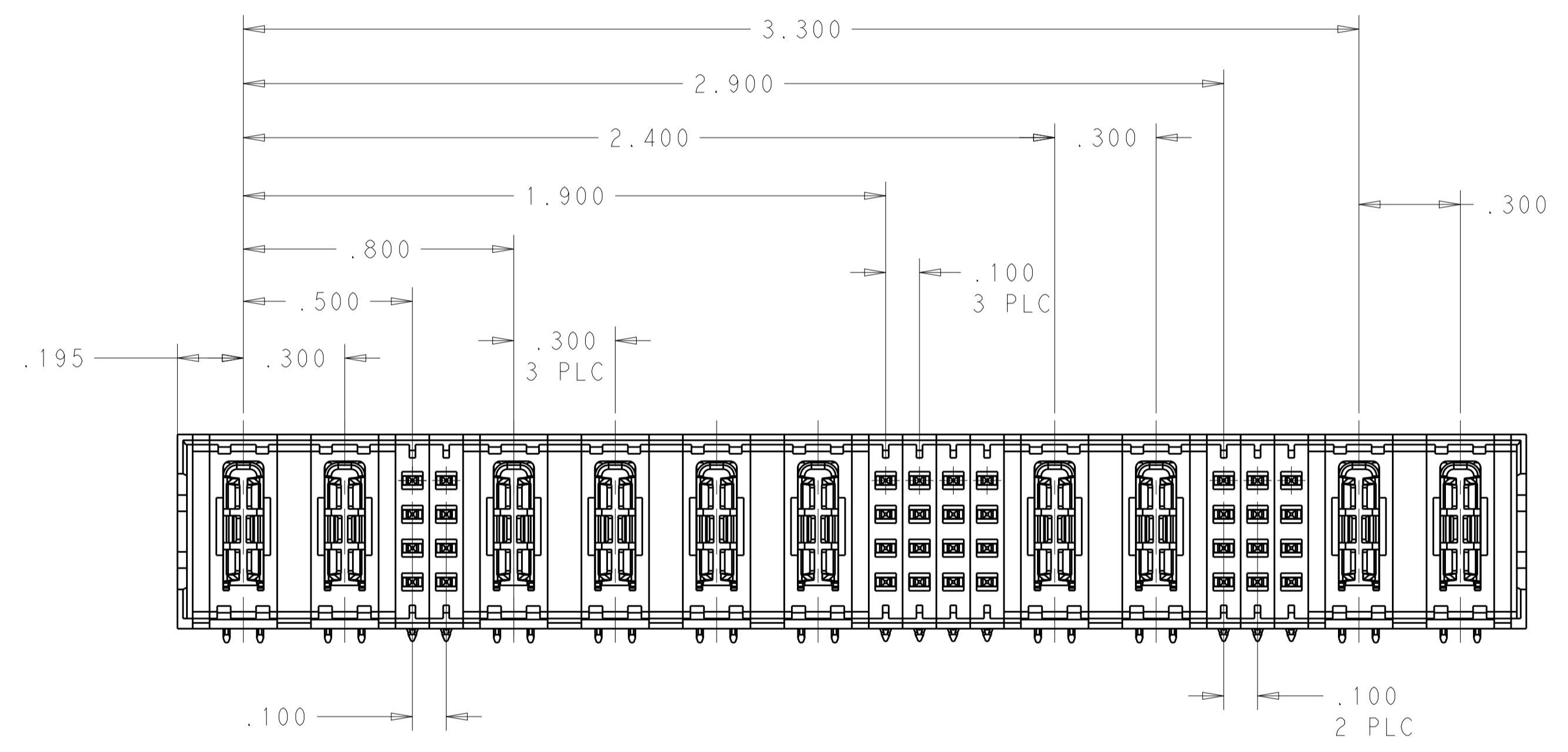

REMARKS	DESCRIPTION	PART NUMBER
SEE SHEETS 3 AND 4	2ACP+1LP+32S+3HDP+1LP+1HDP	2314578-2
SEE SHEETS 1 AND 2	2ACP+8S+4ACP+16S+2ACP+12S+2ACP	2314578-1

2ACP+8S+4ACP+16S+2ACP+12S+2ACP	2314578-1
DESCRIPTION	PART NUMBER

THIS DRAWING IS A CONTROLLED DOCUMENT.

DIMENSIONS: INCHES	TOLERANCES UNLESS OTHERWISE SPECIFIED:	0 PLC ± .010	1 PLC ± .005	2 PLC ± .005	3 PLC ± .005	4 PLC ± .0020	ANGLES ± .020	FINISH #2
--------------------	--	--------------	--------------	--------------	--------------	---------------	---------------	-----------

OWN: Brent D. Yohn	CHK: Dung Hoang	APVD: Dung Hoang	DATE: 10APR2017
PRODUCT SPEC: 108-2292	APPLICATION SPEC: 114-13251	WEIGHT: -	CUSTOMER DRAWING

**STE** TE Connectivity

NAME: RIGHT ANGLE HEADER ASSEMBLY WITH GUIDELESS MULTI-BEAM XLE

SIZE: A1 | CAGE CODE: 00779 | DRAWING NO: 2314578

SCALE: 1:4 | SHEET: 1 OF 4 | REV: A

REVISIONS				
P.	LTN	DESCRIPTION	DATE	APVD
-	-	SEE SHEET 1	-	-

PART NUMBER	ROWS	POWER		SIGNAL		POWER				SIGNAL				POWER		SIGNAL		POWER		
		P1	P2	1	2	P3	P4	P5	P6	3	4	5	6	P7	P8	7	8	9	P9	P10
2314578-1	D C B A	TT	TT	Z5	Z5	TT	TT	TT	TT	Z5	Z5	Z5	Z5	TT	TT	Z5	Z5	Z5	TT	TT
				Y5	Y5					Y5	Y5	Y5	Y5			Y5	Y5	Y5		
				R5	R5					R5	R5	R5	R5			R5	R5	R5		
				O5	O5					O5	O5	O5	O5			O5	O5	O5		
2ACP+8S+4ACP+16S+2ACP+12S+2ACP																				

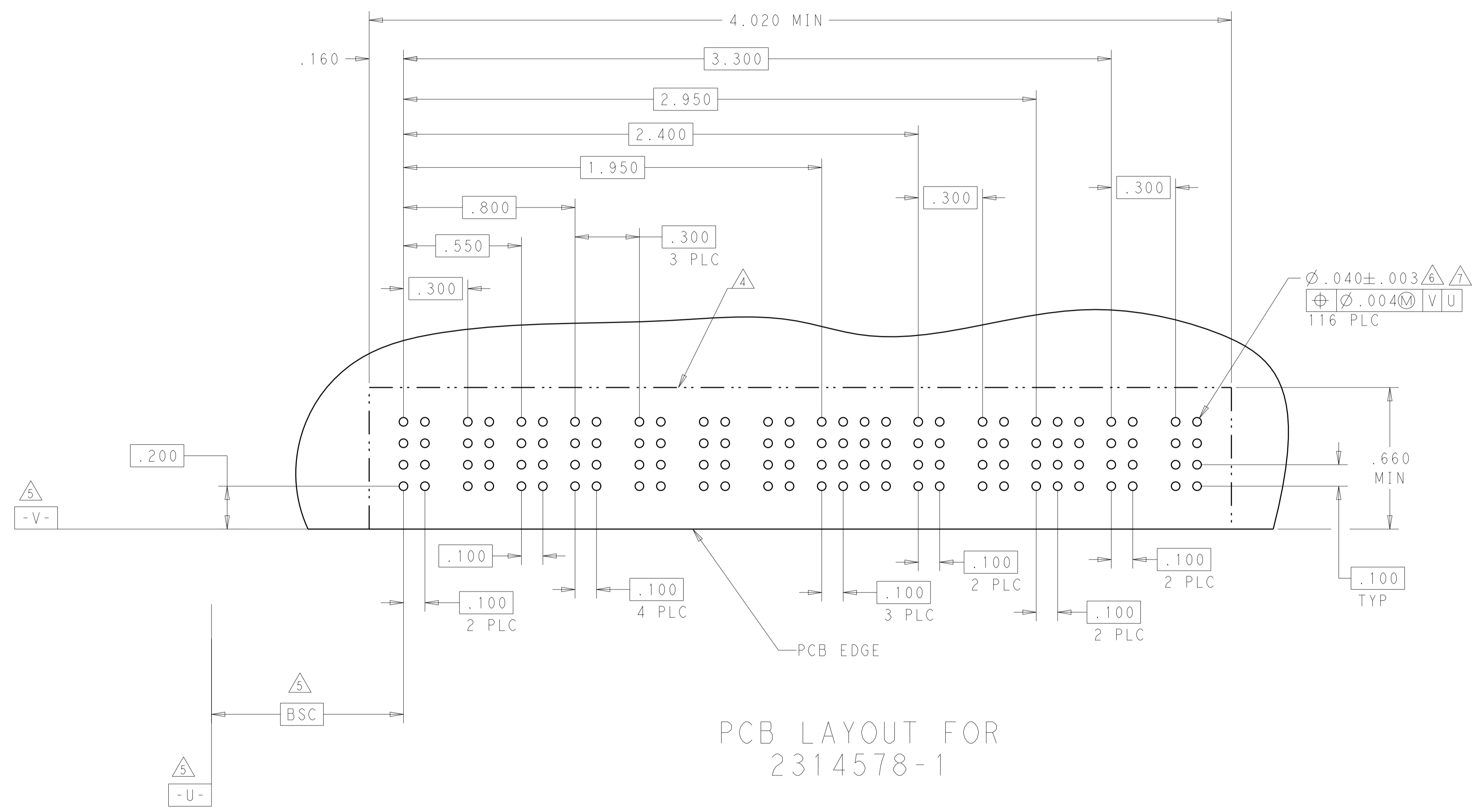

.120 SIGNAL PRESS FIT CON, ROW A,STD	O5
.120 SIGNAL PRESS FIT CON, ROW B,STD	R5
.120 SIGNAL PRESS FIT CON, ROW C,STD	Y5
.120 SIGNAL PRESS FIT CON, ROW D,STD	Z5
.120 PRESS FIT POWER CON	TT
DESCRIPTION	IDENTIFIER

THIS DRAWING IS A CONTROLLED DOCUMENT.		OWN: TAPR2017 Brent D. Yohn	TE Connectivity
DIMENSIONS: INCHES		CHK: 10APR2017 Dung Hoang	
TOLERANCES UNLESS OTHERWISE SPECIFIED:		APVD: 10APR2017 Dung Hoang	NAME: RIGHT ANGLE HEADER ASSEMBLY WITH GUIDELESS MULTI-BEAM XLE
0 PLC ±. 1 PLC ±. 2 PLC ±. 3 PLC ±.005 4 PLC ±.0020 ANGLES ±.2		PRODUCT SPEC: 108-2292	SIZE: CAGE CODE DRAWING NO
MATERIAL: -		APPLICATION SPEC: 114-13251	RESTRICTED TO: -
FINISH: -		WEIGHT: -	A100779C=2314578
		CUSTOMER DRAWING	SCALE: 1:4 SHEET 2 OF 4 REV A

REVISIONS				
P.	LTN	DESCRIPTION	DATE	APVD
-	-	SEE SHEET 1	-	-

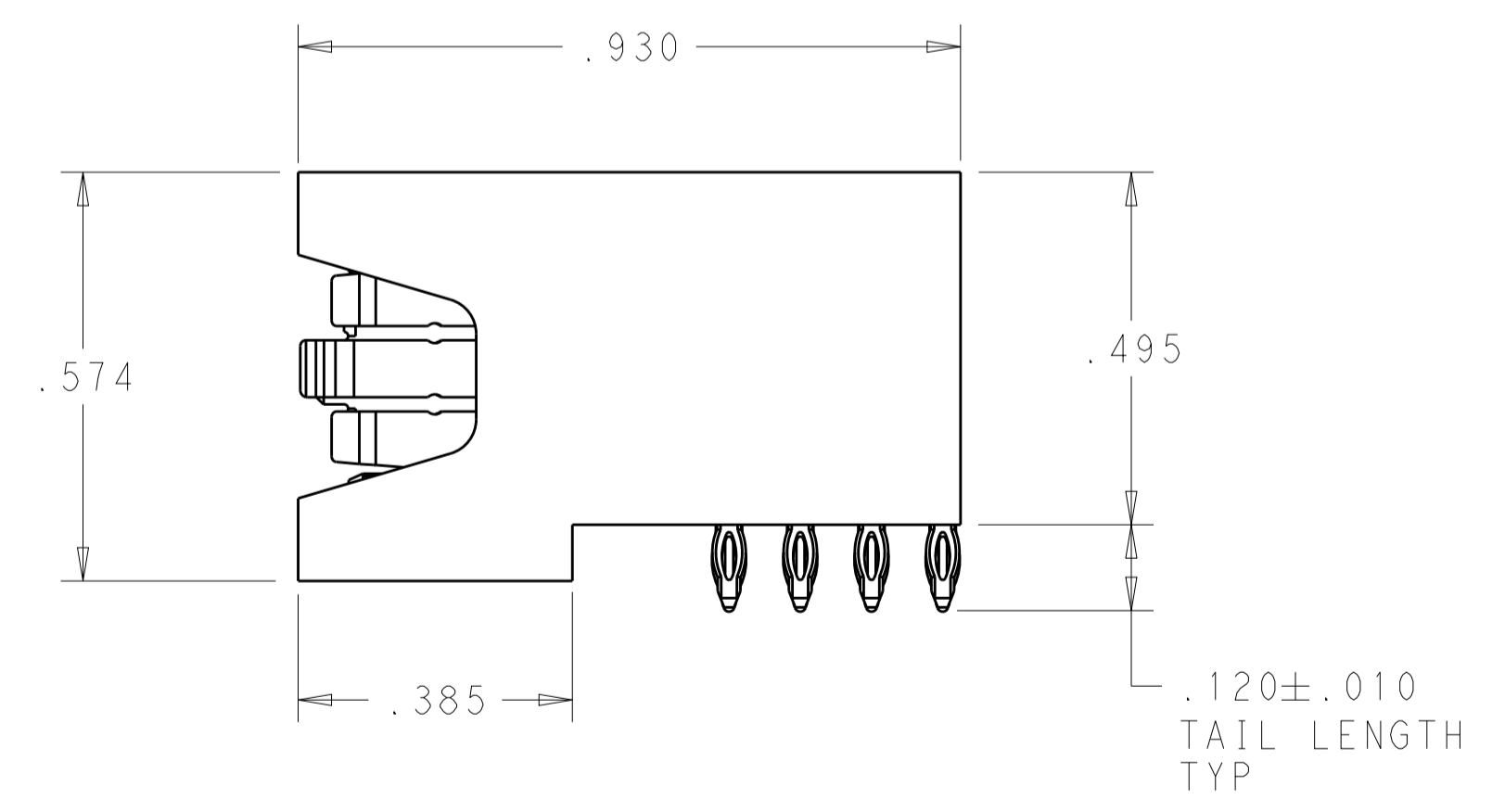
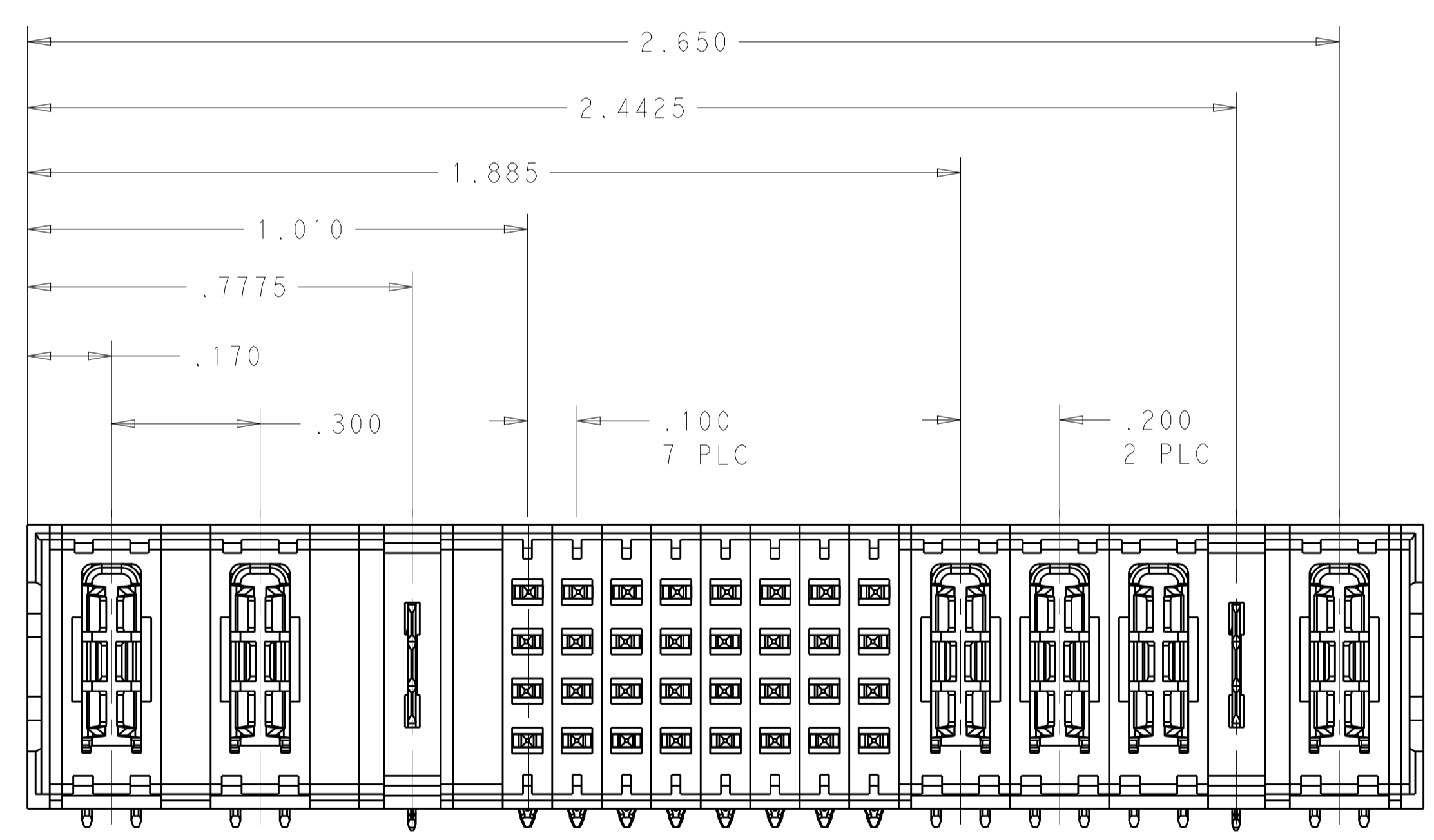
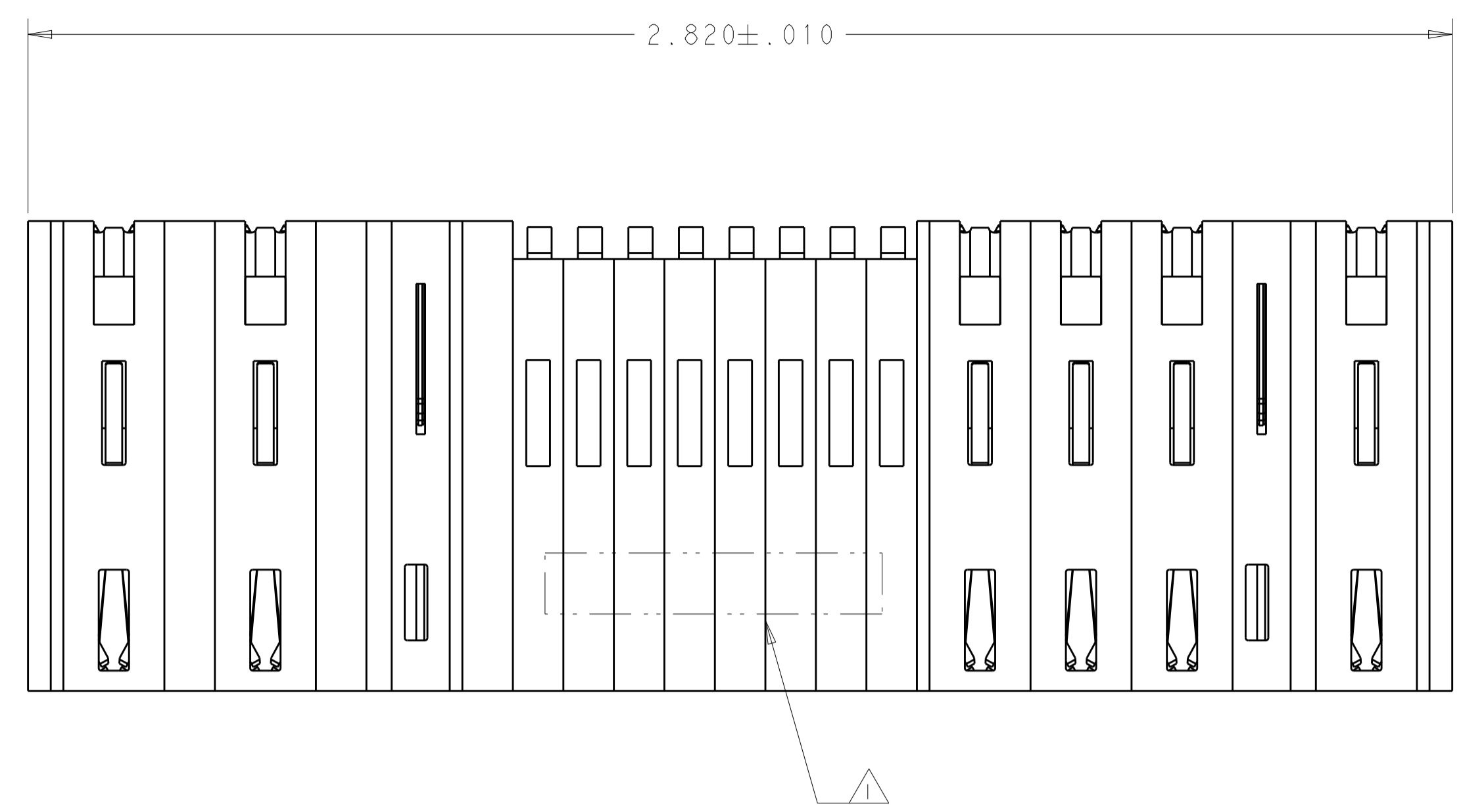

2ACP + 1LP + 32S + 3HDP + 1LP + 1HDP	2314578-2
DESCRIPTION	PART NUMBER

THIS DRAWING IS A CONTROLLED DOCUMENT.		DWN: Brent D. Yohn 10APR2017 CHK: Dung Hoang 10APR2017 APVD: Dung Hoang 10APR2017	TE Connectivity
DIMENSIONS: INCHES	TOLERANCES UNLESS OTHERWISE SPECIFIED: 0 PLC ±. 1 PLC ±. 2 PLC ±. 3 PLC ±.005 4 PLC ±.0020 ANGLES ±.2	NAME: RIGHT ANGLE HEADER ASSEMBLY WITH GUIDELESS MULTI-BEAM XLE PRODUCT SPEC: 108-2292 APPLICATION SPEC: 114-13251 WEIGHT: -	
MATERIAL: -	FINISH: -	CUSTOMER DRAWING SCALE: 1:4 SHEET: 3 OF 4 REV: A	SIZE: A100779 CAGE CODE: C=2314578

REVISIONS				
P.	LTN	DESCRIPTION	DATE	APVD
-	-	SEE SHEET 1	-	-

PART NUMBER	ROWS	POWER			SIGNAL								POWER					
		P1	P2	LP1	1	2	3	4	5	6	7	8	P3	P4	P5	LP2	P6	
2314578-2	D				Z5	Z5	Z5	Z5	Z5	Z5	Z5	Z5						
	C				Y5	Y5	Y5	Y5	Y5	Y5	Y5	Y5						
	B	TT	TT	LT	R5	R5	R5	R5	R5	R5	R5	R5	TT	TT	TT	LT	TT	
	A				O5	O5	O5	O5	O5	O5	O5	O5						

2ACP+1LP+32S+3HDP+1LP+1HDP

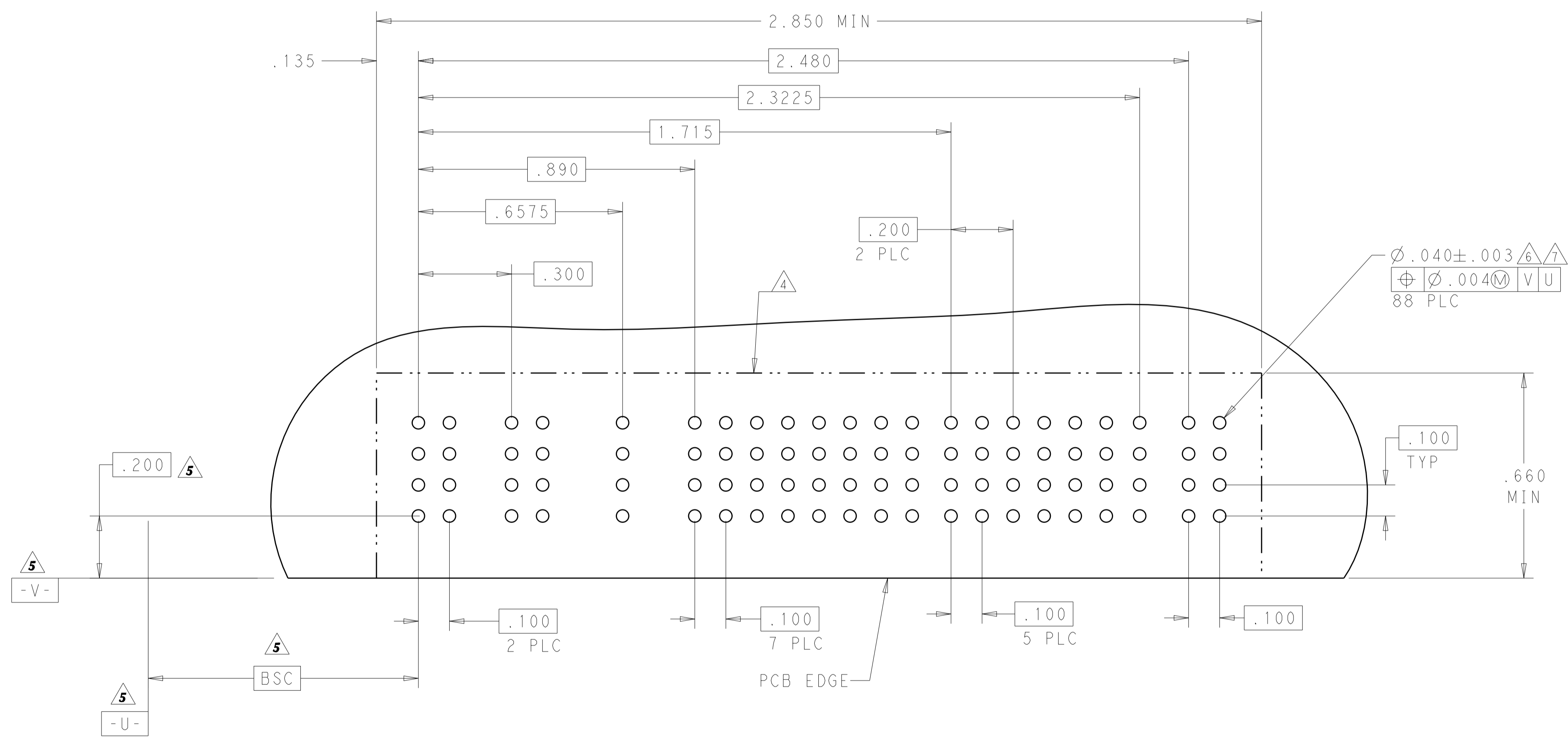

PCB LAYOUT FOR  
2314578-2

DESCRIPTION	IDENTIFIER
HOLD DOWN	HD
.120 SIGNAL PRESS FIT CON, ROW A,MLBF	O1
.120 SIGNAL PRESS FIT CON, ROW A,STD	O5
.120 SIGNAL PRESS FIT CON, ROW B,STD	R5
.120 SIGNAL PRESS FIT CON, ROW C,STD	Y5
.120 SIGNAL PRESS FIT CON, ROW D,STD	Z5
.120 PRESS FIT LOWER POWER CON,STD	LT
.120 PRESS FIT POWER CON	TT

THIS DRAWING IS A CONTROLLED DOCUMENT.

DIMENSIONS: INCHES	TOLERANCES UNLESS OTHERWISE SPECIFIED: 0 PLC ± 1 PLC ± 2 PLC ± 3 PLC ±.005 4 PLC ±.0020 ANGLES ±2	FINISH	APVD: <b>Dung Hoang</b> 10APR2017	NAME: <b>RIGHT ANGLE HEADER ASSEMBLY WITH GUIDELESS MULTI-BEAM XLE</b>
MATERIAL	WEIGHT	114-13251	SIZE: <b>A100779</b>	RESTRICTED TO: <b>C=2314578</b>
CUSTOMER DRAWING			SCALE: 1:4	SHEET 4 OF 4 REV A

TE Connectivity

# Mouser Electronics

Authorized Distributor

Click to View Pricing, Inventory, Delivery & Lifecycle Information:

[TE Connectivity:](#)

[2314578-1](#)