

THIN FILM PRECISION RESISTORS

TYPE CPF SERIES

INTRODUCTION

TE Connectivity (TE)'s CPF series is a high stability precision chip resistor range offering various power dissipations relating to a wide range of chip sizes. The CPF series offers TCR's down to 15 ppm/°C and resistance tolerances to 0.05 %. Standard values are within the IEC 63 E96 and E24 value grids. The CPF has accurate and uniform physical dimensions to facilitate placement.



FEATURES

- Thin film precision resistors with TC's to 15ppm and tolerances to 0.05 %.
- Wide range of case sizes from 0201 to 2512
- Suitable for all applications where close accuracy and stability are essential
- Terminal finish – electroplated 100 % matte Sn
- AEC-Q200 Compliance
- Moisture Sensitivity Level – MSL1

Note: SMD (Surface mount devices) resistors and inductors should be kept in their original packaging to protect them from ESD (Electrostatic Discharge). The full reels can be broken into smaller quantities, without exposing them to ESD, as long as the components are still in the plastic or paper tape. These resistors and inductors should not be removed from the plastic or paper tape unless they are in an ESD protected environment.

APPLICATIONS

- Communications
- Industrial Controls
- Instrumentation
- Medical

ELECTRICAL CHARACTERISTICS

Chip Size		0201					
Rated Power @ 70 °C		0.03125 W					
Resistance Range Ω	Min.	22R	22R	22R	22R	22R	22R
	Max	75K	75K	75K	75K	75K	75K
Tolerance		0.1		0.5		1	
Code Letter		B		D		F	
Selection series		E24 & E96					
Temp. Coefficient (ppm/°C)		25	50	25	50	25	50
Code Letter		E	C	E	C	E	C
Operating Voltage (Max)		15V					
Max. Overload Voltage		30V					
Operating Temp. Range		-55 °C ~ +155 °C					
Insulation Resistance dry min.		>1000 MΩ					
Stability		0.5%					

Thin Film Precision Resistors

Type CPF Series

Chip Size		0402											
Rated Power @ 70 °C		0.063 W											
Resistance Range Ω	Min.	49R9	49R9	49R9	4R0	49R9	4R0	49R9	4R0	49R9	4R0		
	Max	20K	12K	100K	511K	100K	511K	100K	511K	100K	511K		
Tolerance		0.05			0.1			0.5			1		
Code Letter		A			B			D			F		
Selection series		E24 & E96											
Temp. Coefficient (ppm/°C)		15	25	50	15	25	50	15	25	50	15	25	50
Code Letter		D	E	C	D	E	C	D	E	C	D	E	C
Operating Voltage (Max)		50 V											
Max. Overload Voltage		100 V											
Operating Temp. Range		-55 °C ~ +155 °C											
Insulation Resistance dry min.		>1000 M Ω											
Stability		0.5 %											

Chip Size		0603											
Rated Power @ 70 °C		0.063 W											
Resistance Range Ω	Min.	4R7	4R7	1R0	4R7	1R0	4R7	1R0	4R7	1R0			
	Max	332K	511K	1M0	511K	1M0	511K	1M0	511K	1M0			
Tolerance		0.05			0.1			0.5			1		
Code Letter		A			B			D			F		
Selection series		E24 & E96											
Temp. Coefficient (ppm/°C)		15	25	50	15	25	50	15	25	50	15	25	50
Code Letter		D	E	C	D	E	C	D	E	C	D	E	C
Operating Voltage (Max)		50 V											
Max. Overload Voltage		100 V											
Operating Temp. Range		-55 °C ~ +155 °C											
Insulation Resistance dry min.		>1000 M Ω											
Stability		0.5 %											

Chip Size		0805											
Rated Power @ 70 °C		0.1 W											
Resistance Range Ω	Min.	4R7	1R0	4R7	1R0	4R7	1R0	4R7	1R0	4R7	1R0		
	Max	1M0	2M0	1M0	2M0	1M0	2M0	1M0	2M0	1M0	2M0		
Tolerance		0.05			0.1			0.5			1		
Code Letter		A			B			D			F		
Selection series		E24 & E96											
Temp. Coefficient (ppm/°C)		15	25	50	15	25	50	15	25	50	15	25	50
Code Letter		D	E	C	D	E	C	D	E	C	D	E	C
Operating Voltage (Max)		100 V											
Max. Overload Voltage		200 V											
Operating Temp. Range		-55 °C ~ +155 °C											
Insulation Resistance dry min.		>1000 M Ω											
Stability		0.5 %											

Thin Film Precision Resistors

Type CPF Series

Chip Size		1206											
Rated Power @ 70 °C		0.125 W											
Resistance Range Ω	Min.	4R7	4R7	4R7	1R0	4R7	1R0	4R7	1R0	4R7	1R0		
	Max	1M5	1M0	1M5	3M	1M5	3M	1M5	3M	1M5	3M		
Tolerance		0.05			0.1			0.5			1		
Code Letter		A			B			D			F		
Selection series		E24 & E96											
Temp. Coefficient (ppm/°C)		15	25	50	15	25	50	15	25	50	15	25	50
Code Letter		D	E	C	D	E	C	D	E	C	D	E	C
Operating Voltage (Max)		150 V											
Max. Overload Voltage		300 V											
Operating Temp. Range		-55 °C ~ +155 °C											
Insulation Resistance dry min.		>1000 MΩ											
Stability		0.5 %											

Chip Size		1210											
Rated Power @ 70 °C		0.125 W											
Resistance Range Ω	Min.	4R7	4R7	4R7	1R0	4R7	1R0	4R7	1R0	4R7	1R0		
	Max	1M5	1M0	1M5	3M	1M5	3M	1M5	3M	1M5	3M		
Tolerance		0.05			0.1			0.5			1		
Code Letter		A			B			D			F		
Selection series		E24 & E96											
Temp. Coefficient (ppm/°C)		15	25	50	15	25	50	15	25	50	15	25	50
Code Letter		D	E	C	D	E	C	D	E	C	D	E	C
Operating Voltage (Max)		150 V											
Max. Overload Voltage		300 V											
Operating Temp. Range		-55 °C ~ +155 °C											
Insulation Resistance dry min.		>1000 MΩ											
Stability		0.5 %											

Chip Size		2010											
Rated Power @ 70 °C		0.25 W											
Resistance Range Ω	Min.	4R7	4R7	1R0	4R7	1R0	4R7	1R0	4R7	1R0			
	Max	1M0	1M0	3M0	1M0	3M0	1M0	3M0	1M0	3M0			
Tolerance		0.05			0.1			0.5			1		
Code Letter		A			B			D			F		
Selection series		E24 & E96											
Temp. Coefficient (ppm/°C)		15	25	50	15	25	50	15	25	50	15	25	50
Code Letter		D	E	C	D	E	C	D	E	C	D	E	C
Operating Voltage (Max)		150 V											
Max. Overload Voltage		300 V											
Operating Temp. Range		-55 °C ~ +155 °C											
Insulation Resistance dry min.		>1000 MΩ											
Stability		0.5 %											

Thin Film Precision Resistors

Type CPF Series

Chip Size		2512											
Rated Power @ 70 °C		0.5 W											
Resistance Range Ω	Min.	4R7			4R7	1R0	4R7	1R0	4R7	1R0			
	Max	1M0			1M0	3M0	1M0	3M0	1M0	3M0			
Tolerance		0.05			0.1			0.5			1		
Code Letter		A			B			D			F		
Selection series		E24 & E96											
Temp. Coefficient (ppm/°C)		15	25	50	15	25	50	15	25	50	15	25	50
Code Letter		D	E	C	D	E	C	D	E	C	D	E	C
Operating Voltage (Max)		150 V											
Max. Overload Voltage		300 V											
Operating Temp. Range		-55 °C ~ +155 °C											
Insulation Resistance dry min.		>1000 MΩ											
Stability		0.5 %											

ENVIRONMENTAL CHARACTERISTICS

Item	Requirement		Test Method
	Tol. ≤0.05%	Tol. >0.05%	
Temperature Coefficient of Resistance (TCR)	As per TCRs specified in Electrical Characteristics tables		MIL-STD-202 Method 304 +25/-55/+25/+125/+25 °C
Short Time Overload	ΔR ±0.05 %	ΔR ±0.2 %	JIS-C-5201-1 4.13 RCWV * 2.5 or Max. overload voltage whichever is lower for 5 seconds
Insulation Resistance	>9999 MΩ		MIL-STD-202 Method 302 Apply 100 VDC for 1 minute
Endurance	ΔR ±0.05 %	ΔR ±0.2 %	MIL-STD-202 Method 108 A 70 ±2 °C, RCWV for 1000 hrs with 1.5 hrs "ON" and 0.5 hrs "OFF"
	O201: >7K Ω ΔR ±0.5 % ≤7K Ω ΔR ±0.2 %		
Damp Heat with Load	ΔR ± 0.3 %		MIL-STD-202 Method 103B 40 ±2 °C, 90-95% R.H. RCWV for 1000 hrs with 1.5 hrs "ON" and 0.5 hrs "OFF"
Bending Strength	ΔR ±0.05 %	ΔR ±0.1 %	JIS-C-5201-1 4.33 Bending amplitude 3 mm for 60 seconds 2010, 2512 sizes: 2 mm Other sizes: 3 mm
Solderability	95% min. coverage		MIL-STD-202 Method 208H 245 ±5 °C for 3 seconds
Resistance to Soldering Heat	ΔR ±0.05 %	ΔR ±0.1 %	MIL-STD-202 Method 210E 260 ±5 °C for 10 seconds
Dielectric Withstand Voltage	By Type		MIL-STD-202 Method 301 Max. overload voltage for 1 minute
Thermal Shock	ΔR ±0.05 %	ΔR ±0.2 %	MIL-STD-202 Method 107G -55 °C ~ 150 °C, 100 cycles
Low Temperature Operation	ΔR ±0.05 %	ΔR ±0.2 %	JIS-C-5201-1 4.36 1 hour, -65 °C, followed by 45 minutes of RCWV

Thin Film Precision Resistors

Type CPF Series

High temperature exposure	$\Delta R \pm 0.05\%$ 0402 $\geq 255.01K$ 0603 $\geq 402.01k$ 0805 $\geq 1.01M$ 1206 $\geq 1.01M$ 1210 $\geq 1.01M$ 2010 $\geq 1.01M$ 2512 $\geq 1.01M$	MIL-STD-202 Method 108 @ 155 °C for 1000 hrs
Temperature cycling	$\Delta R \pm 0.2 \%$	JESD22 Method JA-104 -55°C ~ +125 °C, 1000 cycles
ESD	$\Delta R \pm 0.5 \%$	AEC-Q200-002 Human body model 0402 0603 200V 0805 1206 1000V 1210 2010 2512 2000V
Sulfur test	$\Delta R \pm 2 \%$ (0201 product is excluded)	ASTM-B-809-95 Modified 105 ± 2 °C no power rating for 1000 hrs
Biased humidity	$\Delta R \pm 0.1 \%$ (0201 product is excluded)	MIL-STD-202 Method 103 1000 hrs 85 °C/ 85 % RH 10 % of operating power

RCWV(Rated continuous working voltage)= $\sqrt{P \cdot R}$ or Max. Operating voltage whichever is lower

Storage Temperature: 25 \pm 3°C; Humidity < 80%RH

Shelf Life: 2 years from production date.

DERATING CURVE

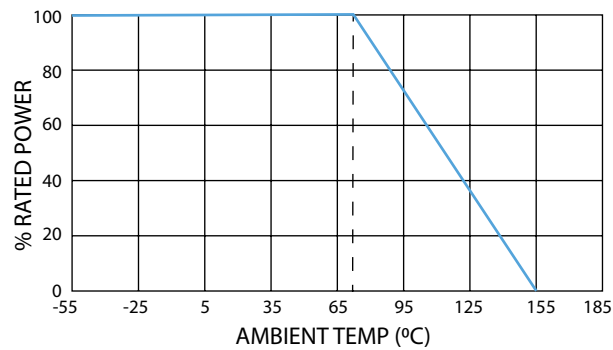

CONSTRUCTION AND DIMENSIONS

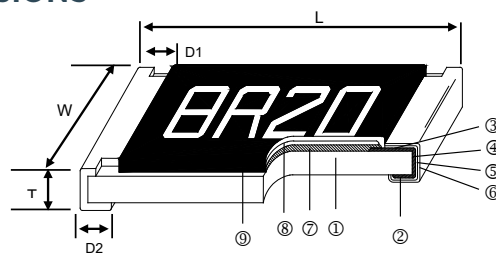

1	Alumina Substrate	4	Edge Electrode (NiCr)	7	Resistor Layer (NiCr)
2	Bottom Electrode (Ag)	5	Barrier Layer (Ni)	8	Overcoat (Epoxy)
3	Top Electrode (Ag)	6	External Electrode (Sn)	9	Marking

Thin Film Precision Resistors

Type CPF Series

TEMPERATURE RISE

Size	L (mm)	W (mm)	T (mm)	D1 (mm)	D2 (mm)	Weight (g) (1000 Pcs.)
0201	0.58 ±0.05	0.29 ±0.05	0.23 ±0.05	0.12 ±0.05	0.15 ±0.05	0.14
0402	1.00 ±0.05	0.50 ±0.05	0.30 ±0.05	0.20 ±0.15	0.20 ±0.10	0.54
0603	1.55 ±0.10	0.80 ±0.10	0.45 ±0.10	0.30 ±0.25	0.30 ±0.20	1.83
0805	2.00 ±0.15	1.25 ±0.15	0.55 ±0.10	0.30 ±0.30	0.40 ±0.20	4.71
1206	3.05 ±0.15	1.55 ±0.15	0.55 ±0.10	0.42 ±0.40	0.35 ±0.25	9.02
1210	3.10 ±0.15	2.40 ±0.15	0.55 ±0.10	0.40 ±0.40	0.55 ±0.25	10
2010	4.90 ±0.15	2.40 ±0.15	0.55 ±0.10	0.60 ±0.40	0.50 ±0.25	23.61
2512	6.30 ±0.15	3.10 ±0.15	0.55 ±0.10	0.60 ±0.40	0.50 ±0.25	38.06

RECOMMENDED LAND PATTERN

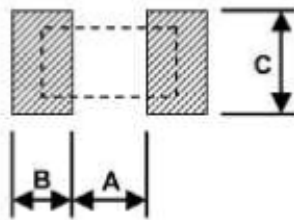

Size	A	B	C
0201	0.25	0.30	0.40 ±0.2
0402	0.50	0.50	0.60 ±0.2
0603	0.80	1.00	0.90 ±0.2
0805	1.00	1.00	1.35 ±0.2
1206	2.00	1.15	1.70 ±0.2
1210	2.00	1.15	2.50 ±0.2
2010	3.60	1.40	2.50 ±0.2
2512	4.90	1.60	3.10 ±0.2

Thin Film Precision Resistors

Type CPF Series

MARKING

Case sizes 0805 to 2512 IEC 4 Digit Marking:

Resistance	100R (100Ω)	2K2 (2.2kΩ)	10K (10kΩ)	499K (499kΩ)	100K (100kΩ)
Code	1000	2201	1002	4992	1003

Case Size 0603 E24 3 digit marking: Example 101 = 100R 102=1K0

E24	10	11	12	13	15	16	18	20	22	24	27	30
	33	36	39	43	47	51	56	62	68	75	82	91

Case size 0603 E96 3 digit marking: Examples 14C = 13K7 68B = 4K99 68X = 49R9

Code	E96	Code	E96	Code	E96	Code	E96
01	100	25	178	49	316	73	562
02	102	26	182	50	324	74	576
03	105	27	187	51	332	75	590
04	107	28	191	52	340	76	604
05	110	29	196	53	348	77	619
06	113	30	200	54	357	78	634
07	115	31	205	55	365	79	649
08	118	32	210	56	374	80	665
09	121	33	215	57	383	81	681
10	124	34	221	58	392	82	698
11	127	35	226	59	402	83	715
12	130	36	232	60	412	84	732
13	133	37	237	61	422	85	750
14	137	38	243	62	432	86	768
15	140	39	249	63	442	87	787
16	143	40	255	64	453	88	806
17	147	41	261	65	464	89	825
18	150	42	267	66	475	90	845
19	154	43	274	67	487	91	866
20	158	44	280	68	499	92	887
21	162	45	287	69	511	93	909
22	165	46	294	70	523	94	931
23	169	47	301	71	536	95	953
24	174	48	309	72	549	96	976

Code	A	B	C	D	E	F	G	H	X	Y	Z
Multiplier	10 ⁰	10 ¹	10 ²	10 ³	10 ⁴	10 ⁵	10 ⁶	10 ⁷	10 ⁻¹	10 ⁻²	10 ⁻³

NB For case size 0603 values other than E24 and E96 resistors will be supplied unmarked.

All resistors smaller than 0603 supplied unmarked.

Thin Film Precision Resistors

Type CPF Series

PACKAGING

Packing Quantity and Reel Specification

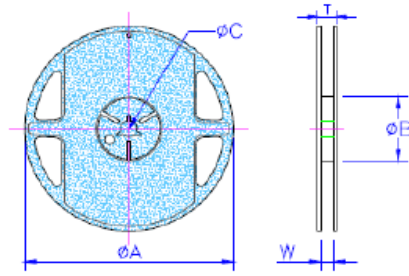

Size	ØA ±1.0	ØB ±1.0	ØC ±0.7	W ±1.0	T ±1.0	Paper Tape	Embossed Plastic Tape
0201	178.0	60.0	13.5	9.5	11.5	1000 / 10000	N/A
0402							
0603							
0805							
1206							
1210							
2010				N/A	4000		
2512							

PAPER TAPE SPECIFICATION

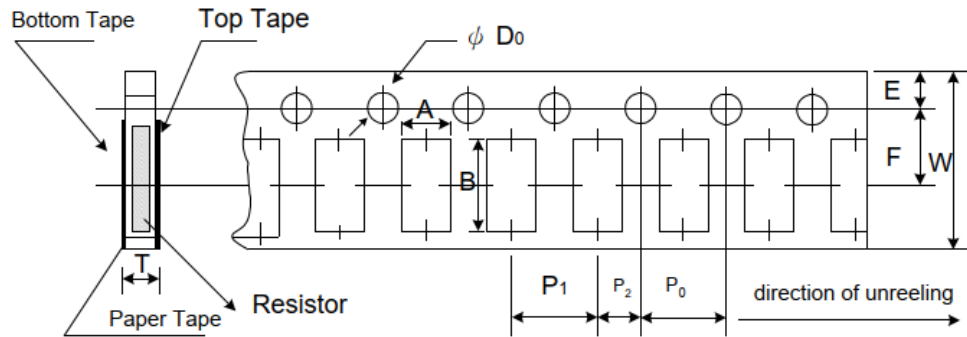

Size	A ±0.05	B ±0.05	W ±0.10	E ±0.05	F ±0.05	P ₀	P ₁	P ₂ ±0.05	ØD ₀	T
0201	0.40	0.70	8.00	1.75	3.5	4.00 ±0.10	2.00 ±0.05	2.00	1.55 ±0.03	0.42 ±0.02
0402	0.70	1.16							1.55 ±0.05	0.40 ±0.03
0603	1.10	1.90							1.55 ±0.05	0.60 ±0.03
0805	1.60	2.37					1.60 ±0.10		0.75 ±0.05	
1206	2.00	3.55								
1210	2.75	3.40								

Thin Film Precision Resistors

Type CPF Series

PEEL FORCE OF TOP COVER TAPE

The peel speed shall be about 300 mm/min $\pm 5\%$

The peel force of top cover tape shall be between 8 gf to 60 gf

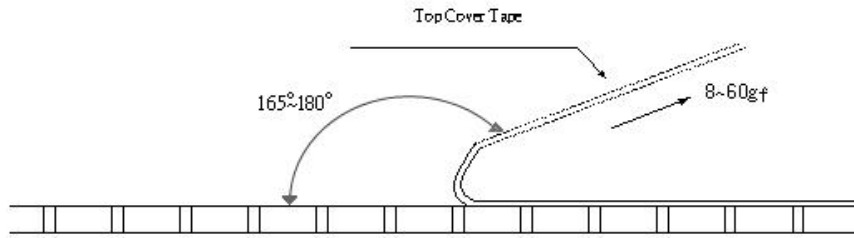

EMBOSED PLASTIC TAPE SPECIFICATIONS

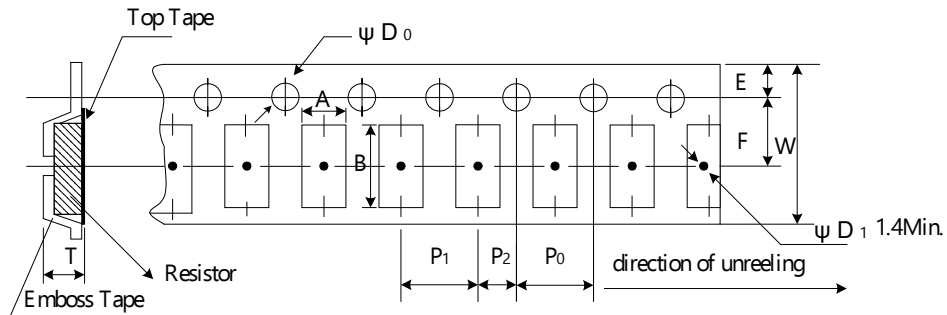

Type	A	B	W	E	F	P_0	P_1	P_2	ϕD_0	T
2010	2.85 ± 0.10	5.45 ± 0.10	12.0 ± 0.10	1.75 ± 0.10	5.5 ± 0.05	4.00 ± 0.05	4.00 ± 0.10	2.00 ± 0.05	1.50 ± 0.10	1.00 ± 0.20
2512	3.40 ± 0.10	6.65 ± 0.10	12.0 ± 0.10	1.75 ± 0.10	5.5 ± 0.05	4.00 ± 0.05	4.00 ± 0.10	2.00 ± 0.05	1.50 ± 0.10	1.00 ± 0.20

PEEL FORCE OF TOP COVER TAPE

The peel speed shall be about 300 mm/min $\pm 5\%$

The peel force of top cover tape shall be between 20 gf to 80 g

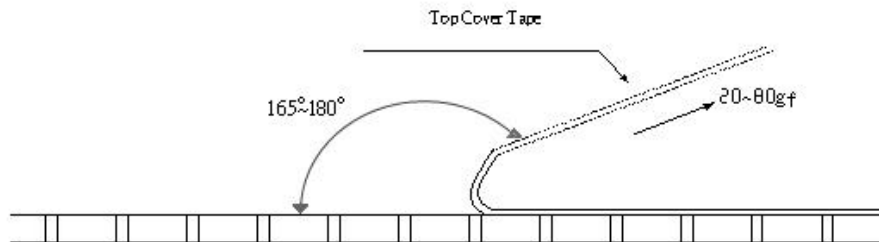

Thin Film Precision Resistors

Type CPF Series

REFLOW SOLDER PROFILE (IPC/JEDEC J-STD-020)

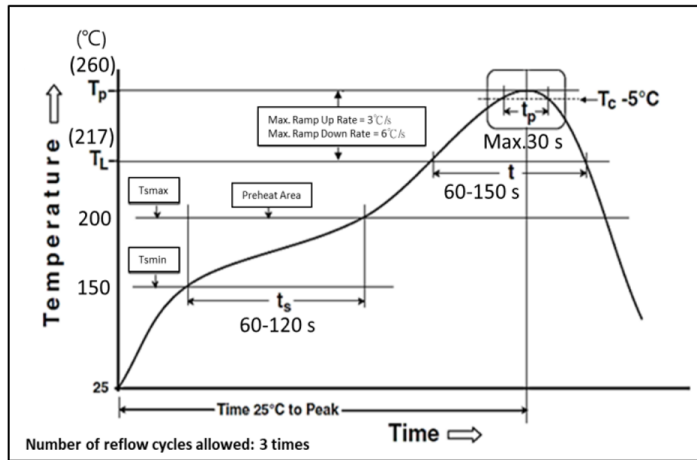

Reflow Profiles	
Profile Feature	Pb-Free Assembly
Preheat	
Minimum temperature (T_{smin})	150 °C
Maximum temperature (T_{smax})	200 °C
Preheating time (t_s) from (T_{smin} to T_{smax})	60-120 seconds
Ramp-up rate (T_L to T_p)	3 °C/second maximum
Liquidous temperature (T_L)	217 °C
Time (t_L) maintained above T_L	60-150 seconds
Minimum peak temperature (T_p min)	235°C
Maximum peak temperature (T_p max)	260°C
Time (t_p) within 5 °C of the specified classification temperature (T_c)	30 seconds max.
Ramp-down rate (T_p to T_L)	6 °C/second max.
Time 25 °C to peak temperature	8 minutes max.

ORDERING INFORMATION

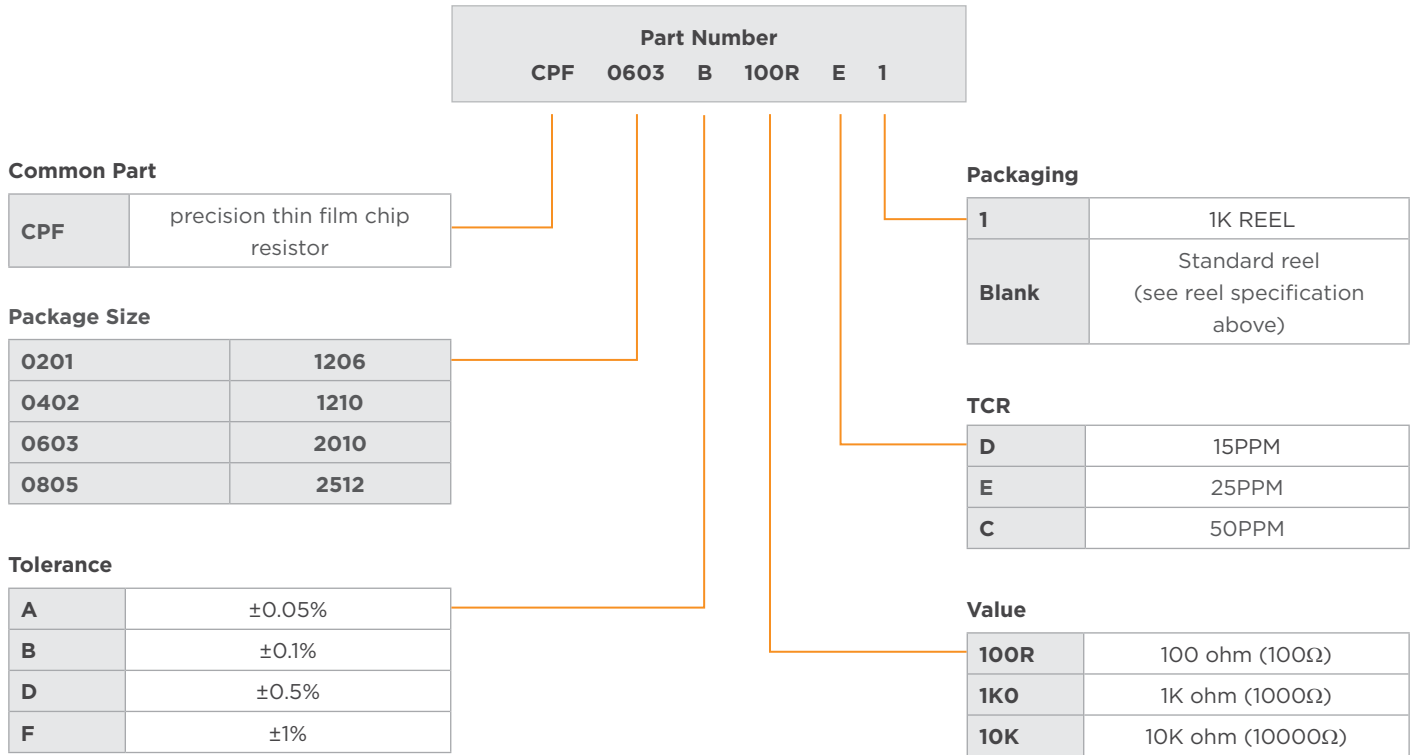

te.com

©2025 TE Connectivity Plc. Family of Companies. All Rights Reserved.

TE Connectivity, TE connectivity (logo) and Every Connection Counts are trademarks owned or licensed by the TE Connectivity Plc. family of companies. All other logos, products and/or company names referred to herein might be trademarks of their respective owners.

While TE has made every reasonable effort to ensure the accuracy of the information in this document, TE does not guarantee that it is error-free, nor does TE make any other representation, warranty or guarantee that the information is accurate, correct, reliable or current. TE reserves the right to make any changes to the information contained herein without prior notice. TE Connectivity assumes only those obligations set forth in the terms and conditions for this product and shall in no event be liable for any incidental, indirect, or consequential damages arising out of the sale, resale, use, or misapplication of the product. TE expressly disclaims any implied warranties with respect to the information contained herein, including, but not limited to, implied warranties of merchantability or fitness for a particular purpose. Dimensions, specifications and/or information contained herein are for reference purposes only and are subject to change without notice. Consult TE for the latest dimensions, specifications and/or information. Users of TE Connectivity products must make their own assessment as to whether the respective product is suitable for the respective desired application.

01/25 1773200 REV:P ED

Mouser Electronics

Authorized Distributor

Click to View Pricing, Inventory, Delivery & Lifecycle Information:

[TE Connectivity:](#)

[CPF0603B43KE1](#) [CPF0603B237KE1](#) [CPF0603B261KE1](#) [CPF0603B287KE1](#) [CPF1206B78K7E1](#)
[CPF0603F1K27C1](#) [CPF0603F14K3C1](#) [CPF0603B1K2E1](#) [CPF0402B1K15E1](#) [CPF0402B1K4E1](#) [CPF0402B16K9E1](#)
[CPF0603B787RE1](#) [CPF0603B143KE1](#) [CPF0603B158KE1](#) [CPF0603F8K25C1](#) [CPF0805B57K6E1](#)
[CPF1206B432RE1](#) [CPF0402B1K58E1](#) [CPF0603B3K32E](#) [CPF0603B6R81E1](#) [CPF0603F11KC1](#) [CPF0603F130KC1](#)
[CPF0805B71K5E1](#) [CPF1206B5R36E1](#) [CPF1206B4K87E1](#) [CPF1206B5K49E1](#) [CPF0603B6K8E1](#) [CPF0402B15R4E1](#)
[CPF0805B11KE1](#) [CPF0805B18KE1](#) [CPF0805B46R4E1](#) [CPF0805B118KE1](#) [CPF1206B2K0E1](#) [CPF1206B6K65E1](#)
[CPF0603B18KE1](#) [CPF0603B27KE1](#) [CPF0402B215RE1](#) [CPF0402B34K8E1](#) [CPF0603B12R7E1](#) [CPF1206B115KE1](#)
[CPF0603F15R4C1](#) [CPF0603F1K82C1](#) [CPF0603F18K7C1](#) [CPF0603F19K6C1](#) [CPF0603F20K5C1](#)
[CPF0805B5R11E1](#) [CPF1206B5K1E1](#) [CPF1206B6R98E1](#) [CPF1206B887RE1](#) [CPF0402B24R3E1](#) [CPF0402B41K2E1](#)
[CPF0603B187RE1](#) [CPF0603B2K61E1](#) [CPF0603B36K5E1](#) [CPF1206B140KE1](#) [CPF1206B147KE1](#)
[CPF0603F17R8C1](#) [CPF0603F2K0C1](#) [CPF0603F2K1C1](#) [CPF0603F243KC1](#) [CPF0603F267KC1](#) [CPF0805B180KE1](#)
[CPF0805B226KE1](#) [CPF0805B249KE1](#) [CPF0805B215KE1](#) [CPF1206B12R1E1](#) [CPF1206B13R3E1](#) [CPF0603B30RE1](#)
[CPF0402B51RE1](#) [CPF0402B39R2E1](#) [CPF0402B73K2E1](#) [CPF0603B357RE1](#) [CPF0603F2R55C1](#) [CPF0603F34KC1](#)
[CPF0603F37K4C1](#) [CPF0603F39K2C1](#) [CPF0603F383KC1](#) [CPF0603B680KE1](#) [CPF0805B68KE1](#)
[CPF0805B130KE1](#) [CPF0805B5R76E1](#) [CPF0805B6R04E1](#) [CPF0805B13K3E1](#) [CPF0805B15KE](#) [CPF0402B30R9E1](#)
[CPF0402B51K1E1](#) [CPF0603B200KE1](#) [CPF0603B18R7E1](#) [CPF0603B243RE1](#) [CPF1206B162KE1](#)
[CPF1206B196KE1](#) [CPF0603F24R9C1](#) [CPF0603F26R1C1](#) [CPF0603F27K4C1](#) [CPF0603F30K9C1](#)
[CPF0805B680KE1](#) [CPF0805B10R2E1](#) [CPF0805B127RE1](#) [CPF1206B1K47E1](#) [CPF0402B562RE1](#)