

LOC		DIST		REVISIONS			
P	LTR	DESCRIPTION	DATE	DN	APVD		
D1	REVISED PER	ECO-11-005030	11MAR11	RK	HMR		

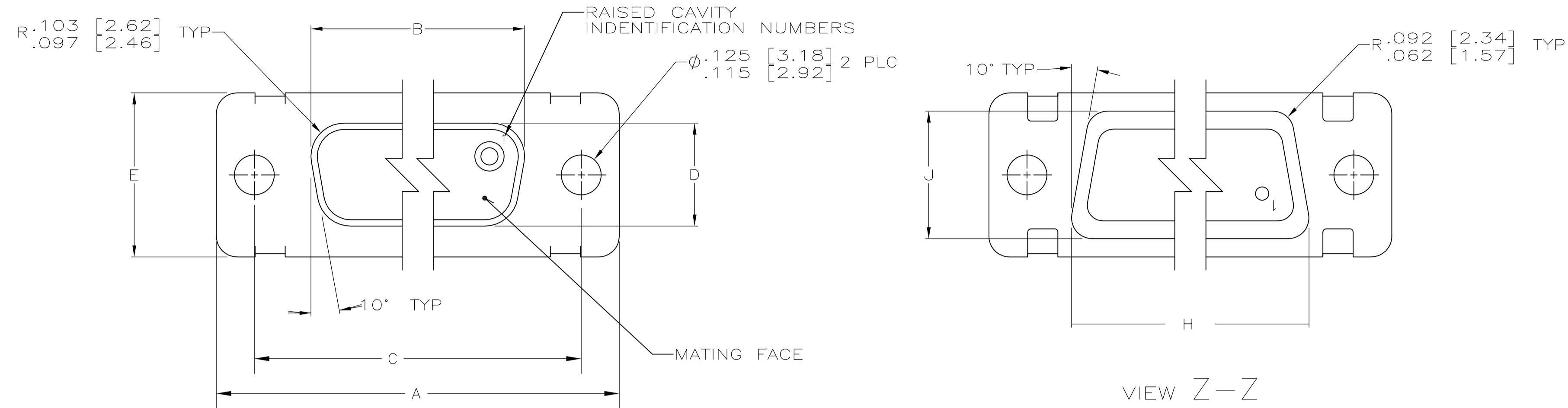

1. SEE SHEET 2 FOR RECOMMENDED P.C. BOARD LAYOUT. TRUE POSITION TOLERANCE FOR P.C. BOARD LAYOUT IS .010 [0.25] AT MAX MATERIAL CONDITION. SUGGESTED BOARD THICKNESS IS .125 [3.18]
2. THE CONNECTORS DESCRIBED IN THIS DOCUMENT MEET THE REQUIREMENTS OF MIL-C-24308 AND MATE WITH ANY PLUG CONNECTOR WITH SAME INSERT ARRANGEMENT.
3. MARK WITH .047 [1.19]-.062 [1.57] HIGH CHARACTERS. FAR SIDE REFERS TO THE WIDE SIDE OF THE KEYSTONE. NEAR SIDE REFERS TO THE NARROW SIDE OF THE KEYSTONE. IF THE REAR SHELL IS TOO SMALL FOR THE ENTIRE MILITARY PART NUMBER, MARKING SHALL BE LOCATED AS FOLLOWS:
 - A. "M24308" ON FRONT SHELL, FAR SIDE.
 - B. SLASH SHEET AND DASH NUMBER ON REAR SHELL, FAR SIDE.
 - C. "AMP" AND DATE CODE ON FRONT SHELL, NEAR SIDE.
 - D. PART NUMBER ON REAR SHELL, NEAR SIDE.
 IF THE FRONT SHELL IS TOO SMALL FOR "AMP", PART NUMBER AND DATE CODE, THEN SPLIT AS FOLLOWS:
 - A. PART NUMBER ON REAR SHELL, NEAR SIDE.
 - B. "AMP" AND DATE CODE ON FRONT SHELL, NEAR SIDE.
 - C. MILITARY PART NUMBER ON REAR SHELL, FAR SIDE.

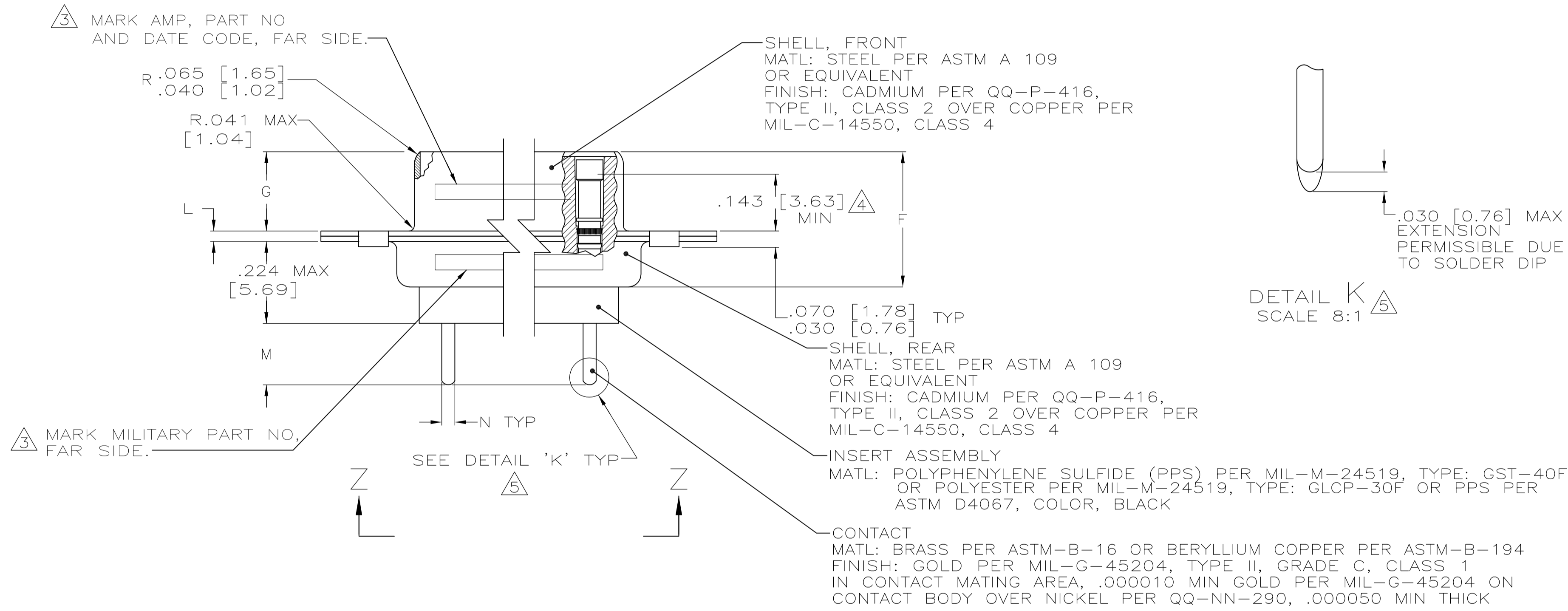

4. POINT OF ELECTRICAL ENGAGEMENT - AS MEASURED WITH A .0390 [0.991]-.0393 [0.998] DIA SQUARE ENDED TEST PIN.
5. SOLDER DIP PER MIL-STD-2000 COMPOSITION Sn63 CONFORMING TO QQ-S-571. COVERAGE SHALL BE COMPLETE TO A DISTANCE .020 [0.51] MAX FROM INSERT ASSEMBLY.
6. THE SOLDER DIP PROCESS IS PERFORMED SUBSEQUENT TO THE COMPLETION OF PRODUCTION OF THE MILITARY QUALIFIED CONNECTOR. DIMENSIONS APPLY PRIOR TO SOLDER DIPPING.
7. SPACERS (QTY 2) ARE SUPPLIED WITH CONNECTORS (NOT ATTACHED TO THE CONNECTOR).
8. DIMENSIONS AND TOLERANCES PER ANSI Y14.5M-1982.
9. THIS DRAWING SHALL BE INTERPRETED IN ACCORDANCE WITH APPLICABLE STANDARDS LISTED IN MIL-STD-100.

N	M	L	J	H	G	F	E	D	C	B	A	INSERT ARRANGEMENT	NO OF POS	SHELL SIZE	MILITARY P/N ON CONNECTOR	P/N ON CONNECTOR	PART NUMBER
.033 [0.84] .027 [0.69]	.176 [4.47] .136 [3.45]	.040 [1.02] .020 [0.51]	.544 [13.82] .524 [13.31]	2.188 [55.58] 2.168 [55.07]	.248 [6.30] .238 [6.05]	.439 [11.15] .419 [10.64]	.620 [15.75] .590 [14.99]	.428 [10.87] .418 [10.62]	2.411 [61.24] 2.401 [60.99]	2.069 [52.55] 2.059 [52.30]	2.650 [67.31] 2.620 [66.55]	MS18277-1	50	5	M24308/23-5F	443975-5	1-443975-0
			2.282 [57.96] 2.262 [57.45]	2.505 [63.63] 2.495 [63.37]			2.164 [54.97] 2.154 [54.71]	2.744 [69.70] 2.714 [68.94]	MS18276-1	37	4	M24308/23-4F	443975-4	443975-9			
.432 [10.97] .412 [10.46]	1.093 [27.76] 1.073 [27.25]	1.635 [41.53] 1.615 [41.02]	.509 [12.93] .479 [12.17]	.316 [8.03] .306 [7.77]	1.857 [47.17] 1.847 [46.91]	1.516 [38.51] 1.506 [38.25]	2.103 [53.42] 2.073 [52.65]	MS18275-1	25	3	M24308/23-3F	443975-3	443975-8				
			1.317 [33.45] 1.307 [33.20]	.976 [24.79] .966 [24.54]				1.556 [39.52] 1.526 [38.76]	MS18274-1	15	2	M24308/23-2F	443975-2	443975-7			
.769 [19.53] .749 [19.02]	1.093 [27.76] 1.073 [27.25]	1.635 [41.53] 1.615 [41.02]	.989 [25.12] .979 [24.87]	.648 [16.46] .638 [16.21]	1.228 [31.19] 1.198 [30.43]	1.317 [33.45] 1.307 [33.20]	.976 [24.79] .966 [24.54]	1.556 [39.52] 1.526 [38.76]	MS18273-1	9	1	M24308/23-1F	443975-1	443975-6			
									MS18277-1	50	5	M24308/23-5F	443975-5	443975-5			
.195 MAX [4.95]	.120 REF [3.05]	.033 [0.84] .027 [0.69]	.544 [13.82] .524 [13.31]	2.188 [55.58] 2.168 [55.07]	.248 [6.30] .238 [6.05]	.439 [11.15] .419 [10.64]	.620 [15.75] .590 [14.99]	.428 [10.87] .418 [10.62]	2.411 [61.24] 2.401 [60.99]	2.069 [52.55] 2.059 [52.30]	2.650 [67.31] 2.620 [66.55]	MS18277-1	50	5	M24308/23-5F	443975-5	443975-5
			2.282 [57.96] 2.262 [57.45]	2.505 [63.63] 2.495 [63.37]			2.164 [54.97] 2.154 [54.71]	2.744 [69.70] 2.714 [68.94]	MS18276-1	37	4	M24308/23-4F	443975-4	443975-4			
.246±.003 [6.25±0.08]	.120 REF [3.05]	.033 [0.84] .027 [0.69]	.432 [10.97] .412 [10.46]	1.635 [41.53] 1.615 [41.02]	1.857 [47.17] 1.847 [46.91]	1.516 [38.51] 1.506 [38.25]	2.103 [53.42] 2.073 [52.65]	MS18275-1	25	3	M24308/23-3F	443975-3	443975-3				
			1.317 [33.45] 1.307 [33.20]	.976 [24.79] .966 [24.54]				1.556 [39.52] 1.526 [38.76]	MS18274-1	15	2	M24308/23-2F	443975-2	443975-2			
.246±.003 [6.25±0.08]	.120 REF [3.05]	.033 [0.84] .027 [0.69]	.769 [19.53] .749 [19.02]	1.093 [27.76] 1.073 [27.25]	.989 [25.12] .979 [24.87]	.648 [16.46] .638 [16.21]	1.228 [31.19] 1.198 [30.43]	MS18273-1	9	1	M24308/23-1F	443975-1	443975-1				
			MS18277-1	50				5	M24308/23-5F	443975-5	443975-5						

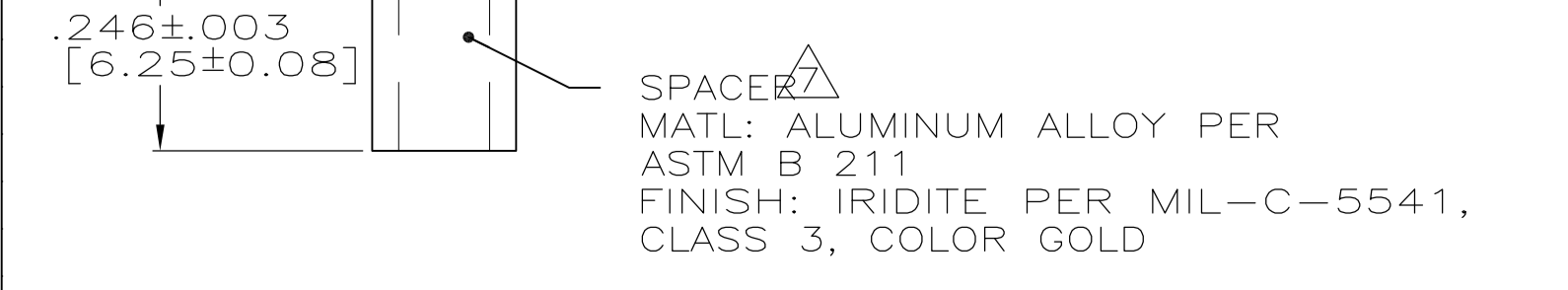

THIS DRAWING IS A CONTROLLED DOCUMENT.

STE TE Connectivity

AMPLIMITE RECEPTACLE ASSY
W/ SIZE 20 POSTED PC BOARD CONTACTS
SERIES 109, SIZES 1 THRU 5

00779-443975

SCALE 4:1 SHEET 1 OF 2 REV D1

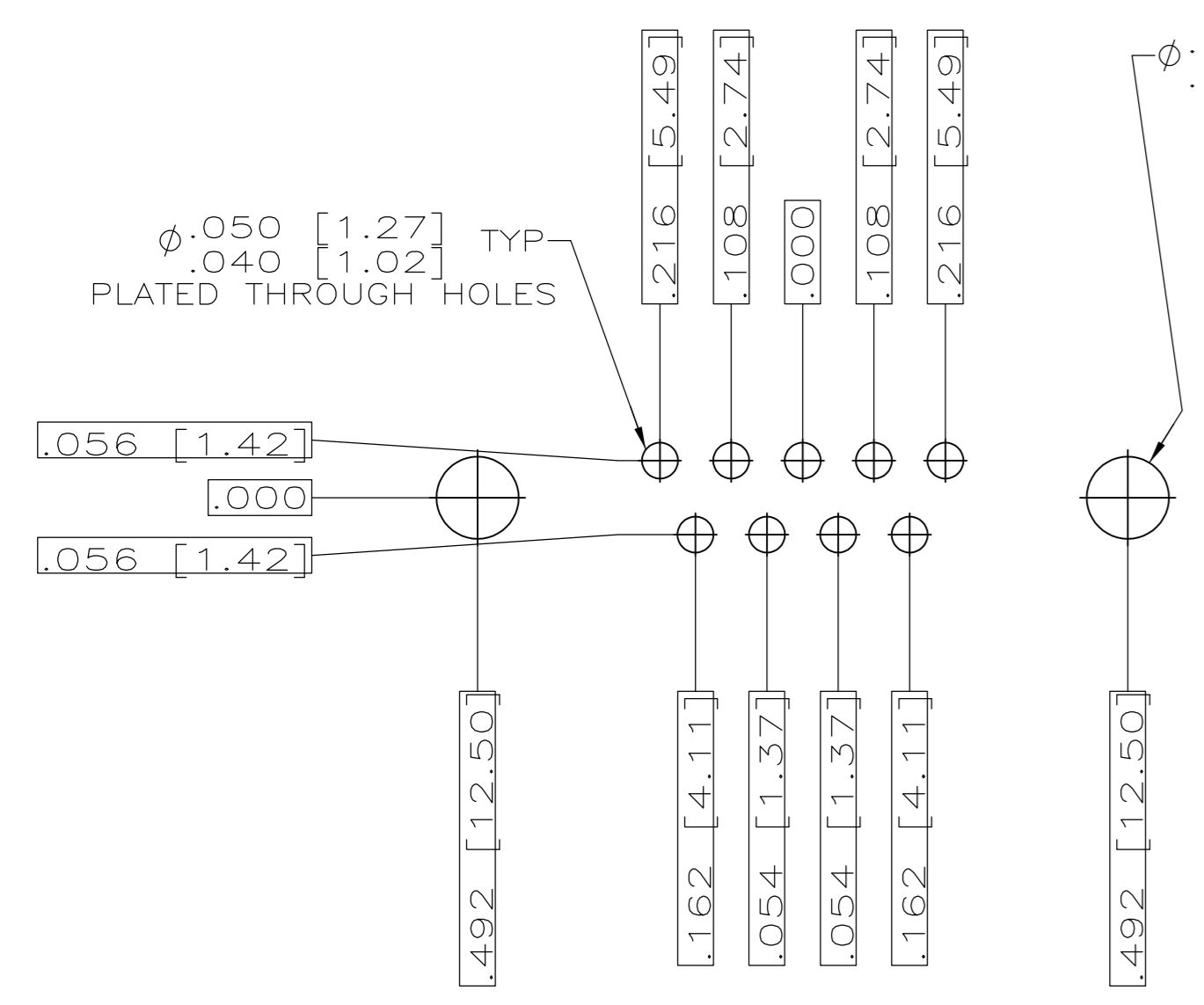

RECOMMENDED P.C. BOARD LAYOUT
SHELL SIZE 1 (9 POSITION) \triangle

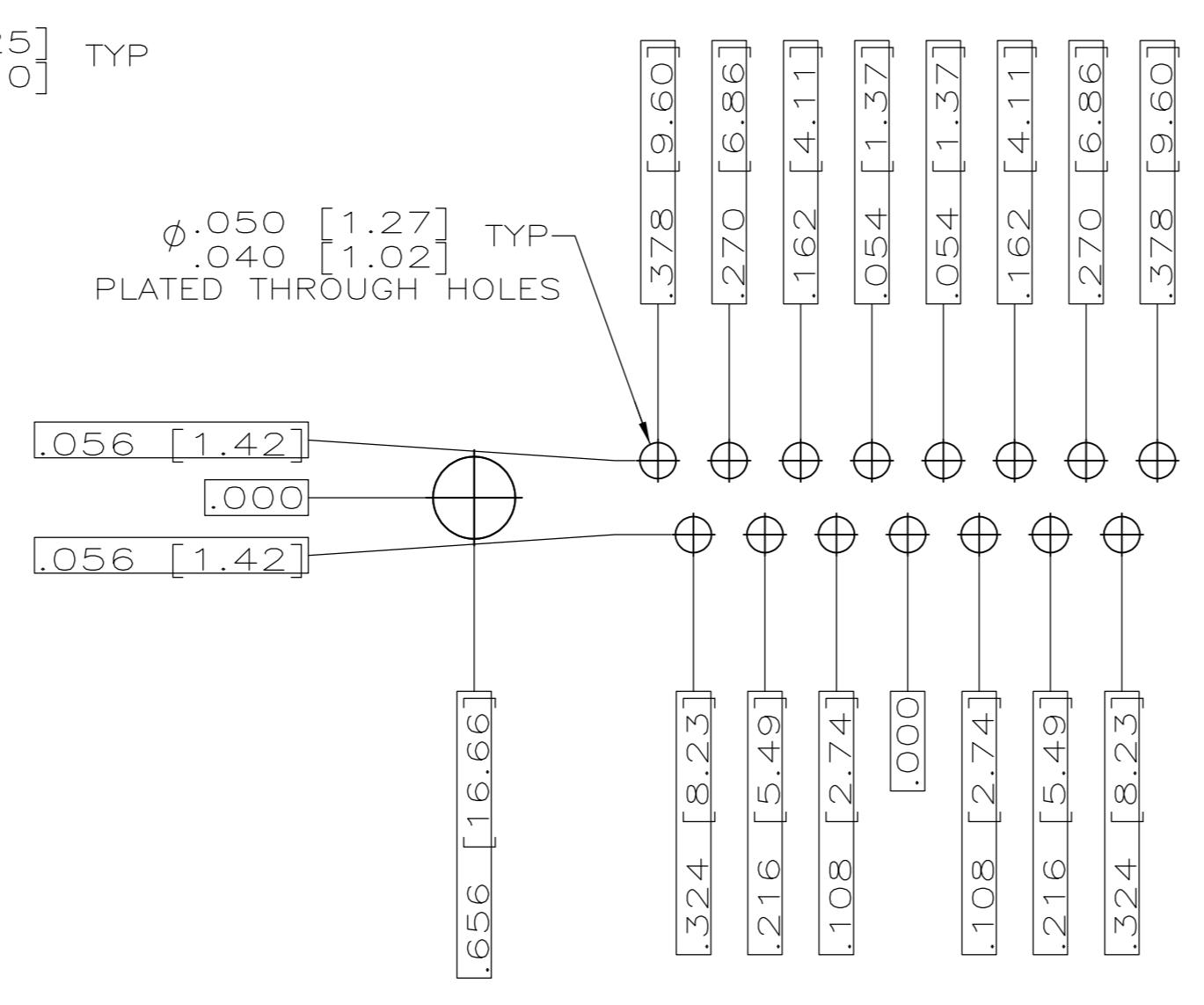

RECOMMENDED P.C. BOARD LAYOUT
SHELL SIZE 2 (15 POSITION) \triangle

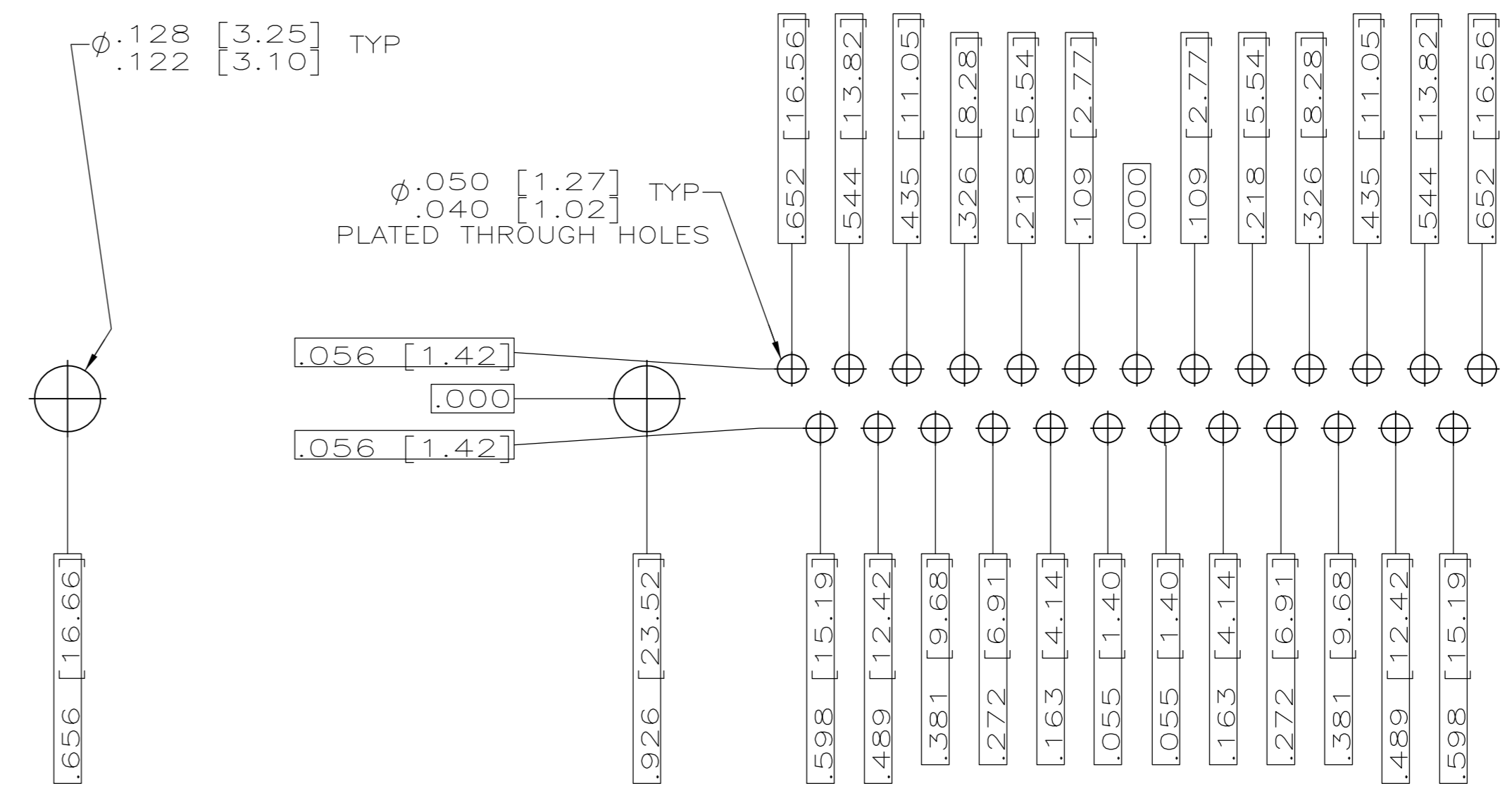

RECOMMENDED P.C. BOARD LAYOUT
SHELL SIZE 3 (25 POSITION) \triangle

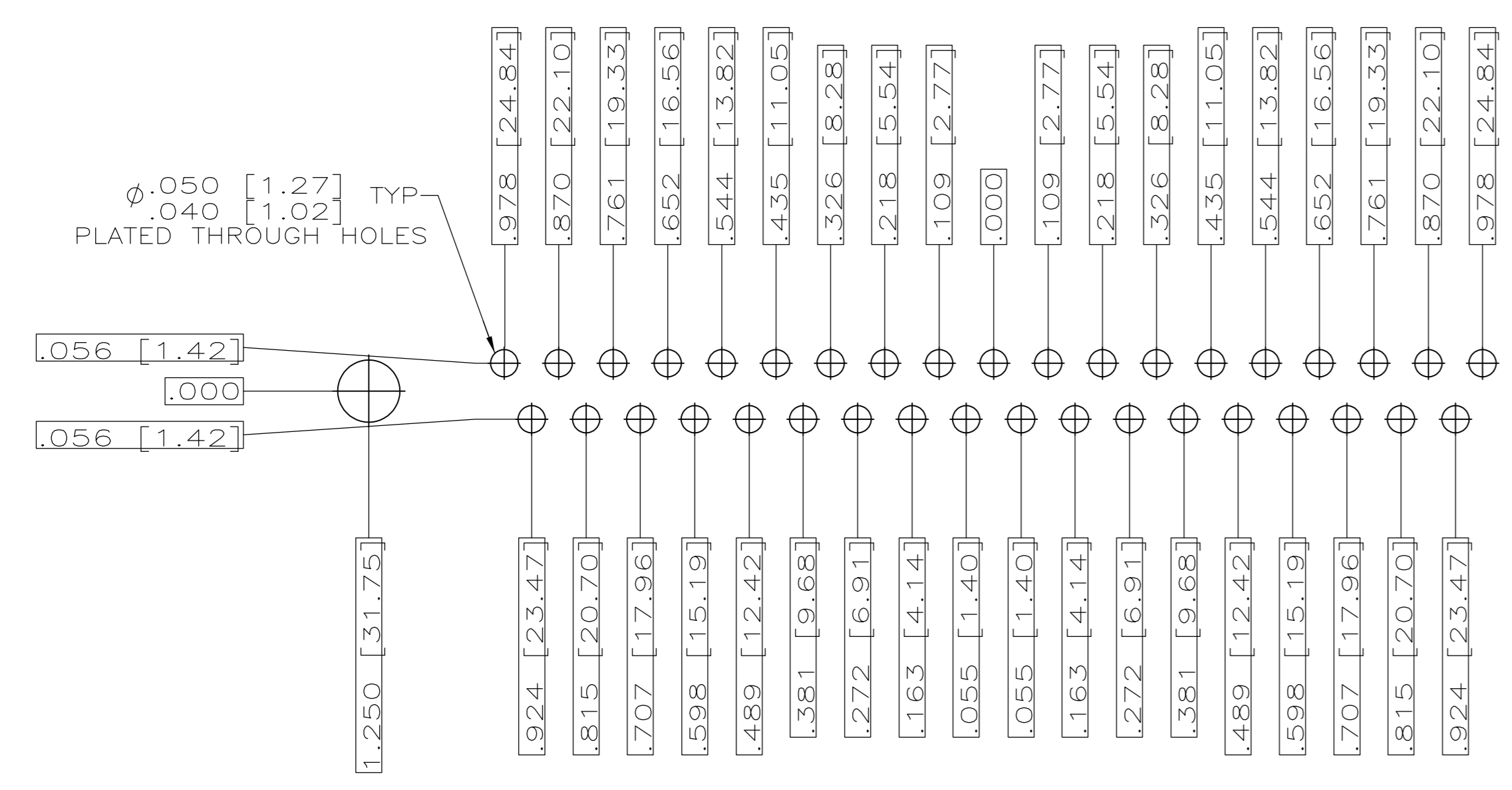

RECOMMENDED P.C. BOARD LAYOUT
SHELL SIZE 4 (37 POSITION) \triangle

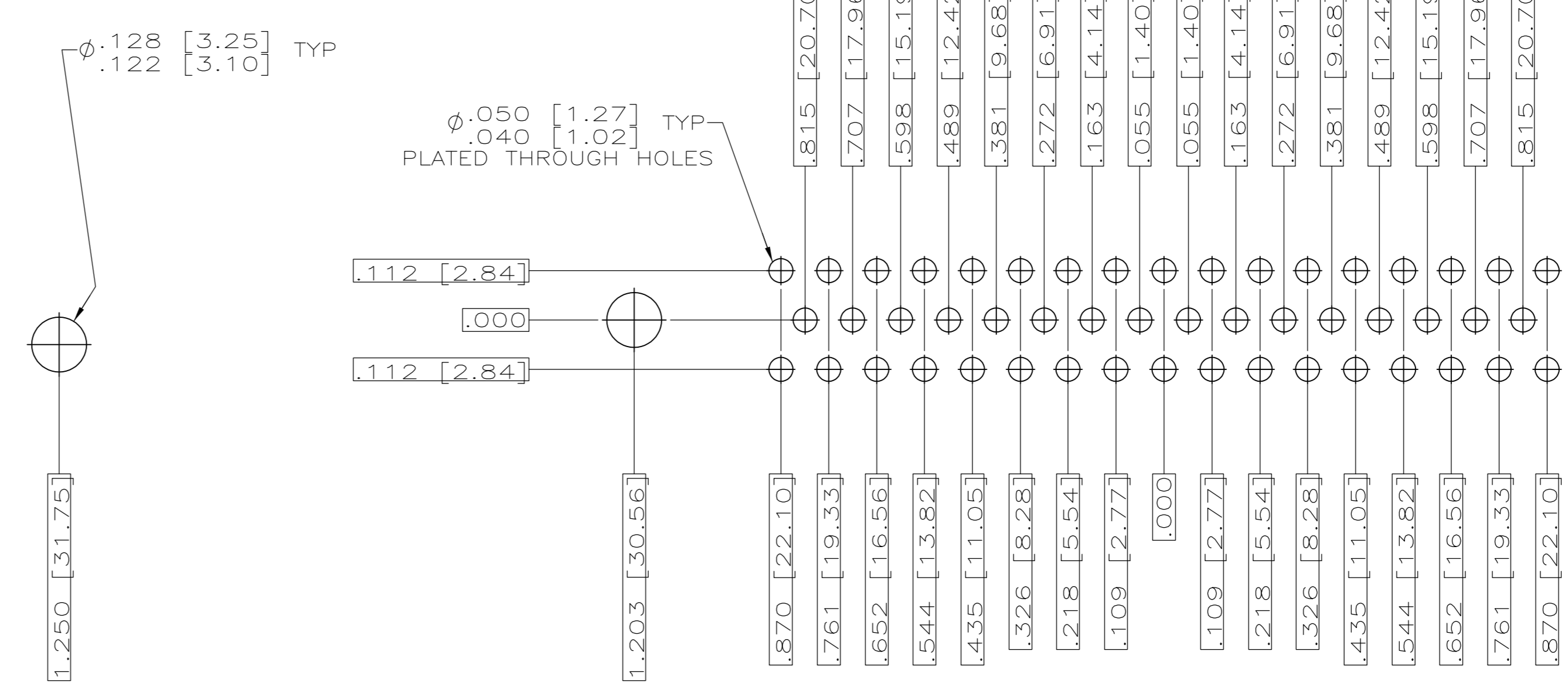

RECOMMENDED P.C. BOARD LAYOUT
SHELL SIZE 5 (50 POSITION) \triangle

THIS DRAWING IS A CONTROLLED DOCUMENT.		DWN J.A. Baker	OSMAY97		TE Connectivity													
DIMENSIONS: INCHES		CHK G. OVER	15MAY98		AMPLIMITE RECEPTACLE ASSY WITH SIZE 20 STRAIGHT POSTED P.C. BOARD CONTACTS, SERIES 109,													
TOLERANCES UNLESS OTHERWISE SPECIFIED:		APVD	-	PRODUCT SPEC MIL-C-24308														
<table border="1"> <tr><td>0 PL</td><td>± .010</td></tr> <tr><td>1 PL</td><td>± .005</td></tr> <tr><td>2 PL</td><td>± .003</td></tr> <tr><td>3 PL</td><td>± .002</td></tr> <tr><td>4 PL</td><td>± .001</td></tr> <tr><td>ANGLES</td><td>± .010</td></tr> </table>		0 PL	± .010	1 PL	± .005	2 PL	± .003	3 PL	± .002	4 PL	± .001	ANGLES	± .010	APPLICATION SPEC		RESTRICTED TO		
0 PL	± .010																	
1 PL	± .005																	
2 PL	± .003																	
3 PL	± .002																	
4 PL	± .001																	
ANGLES	± .010																	
MATERIAL SEE CALLOUTS		WEIGHT		SIZE A1	DWG CODE 00779	DRAWING NO 443975												
FINISH SEE CALLOUTS		CUSTOMER DRAWING		SCALE 4:1	SHEET 2 OF 2	REV D1												

Mouser Electronics

Authorized Distributor

Click to View Pricing, Inventory, Delivery & Lifecycle Information:

[TE Connectivity:](#)

[M24308/23-5F](#)