



QPQ1298

B41 Sub-Band 160 MHz BAW Filter

General Description

The QPQ1298 is an exceptionally high-performance BAW Filter for sub-Band 41 uplink / downlink. This filter is housed in a compact 2.0 x 1.6 mm package for base station applications.

Low insertion loss coupled with high attenuation makes this filter an ideal choice for TDD Macro Cells and Small Cells.

The QPQ1298 is part of Qorvo's extensive portfolio of RF BAW and SAW filters.



3 Pin 2.0 x 1.6 mm leadless SMT Package

Functional Block Diagram

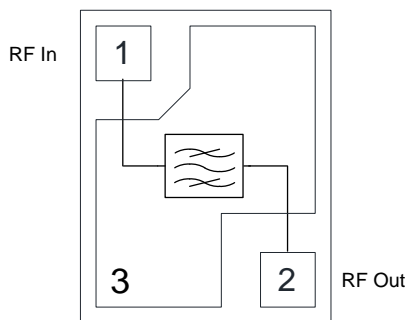

Top View

Pin Configuration

Pin No.	Label
1	RF In
2	RF Out
3	GND Back Side Paddle

Product Features

- 160 MHz Bandwidth – Band 41
- High Attenuation
- Low Loss
- No External Matching Required
- Excellent Wi-Fi Rejection
- Single Input, Single Output Operation
- Small Size: 2.00 x 1.60 x 0.715 mm
- Surface Mount Device
- RoHS Compliant, Pb-Free

Applications

- Band 41
- Base Station Infrastructure
- Small Cells
- Repeaters
- Routers
- LTE Dongles
- General Purpose Wireless

Ordering Information

Part	Description
QPQ1298TR7	2500 pieces on a 7" Reel.
QPQ1298EVB	Evaluation Board – QPQ1298

Absolute Maximum Ratings

Parameter	Rating
Storage Temperature	-40 to 125 °C
Operation Temperature	-40 to +95 °C
RF Input Power, CW, 50 Ω, T=25 °C	37.5 dBm

Exceeding any one or a combination of the Absolute Maximum Rating conditions may cause permanent damage to the device. Extended application of Absolute Maximum Rating conditions to device may reduce device reliability.

Minimum Lifetime Ratings

Conditions	Rating
+29 dBm at Pin 1, 2515-2675 MHz, FD-LTE, 5 MHz, 16 QAM, 25 RB, PAR 8 dB, +95°C	>10 years
+31 dBm at Pin 1, 2515-2675 MHz, FD-LTE, 5 MHz, 16 QAM, 25 RB, PAR 8 dB, +95°C	43,000 hours

Electrical Specifications (1) (2) (3)

Test Conditions unless otherwise noted= -40°C to +95°C

Parameter	Conditions	Min	Typ. (4)	Max	Unit
Frequency Range		2515		2675	MHz
Insertion Loss			2.5	3.3	dB
Amplitude Variation			1.4	2.0	dB
Input VSWR			1.8:1	2.2:1	-
Output VSWR			1.8:1	2.2:1	-
Attenuation (5)	1 - 1785 MHz	30	34		dB
	1785 - 2200 MHz	30	35		dB
	2200 - 2300 MHz	35	41		dB
	2300 - 2400 MHz	46	50		dB
	2400 - 2483.5 MHz	43	46		dB
	2715 - 3000 MHz	38	44		dB
	3300 - 3600 MHz	25	28		dB
	4900 - 5025 MHz	35	38		dB
	5150 - 5350 MHz	35	37		dB
Harmonics	5490 - 5850 MHz	32	35		dB
	H2: 5030-5350 MHz, P _{IN} = 27 dBm @+25 °C	70	79		dBc
	H3: 7545-8025 MHz, P _{IN} = 27 dBm @+25 °C	72	77		dBc

Notes:

1. All specifications are based on the Qorvo schematic shown on page 3.
2. In production, devices will be tested at room temperature to a guard banded specification to ensure compliance over temperature.
3. Electrical margin has been built into the design to account for variations due to temperature drift and manufacturing tolerances.
4. Typical values are based on average measurements at room temperature.
5. Attenuation is referenced to ZERO dB.

QPQ1298EVB Evaluation Board

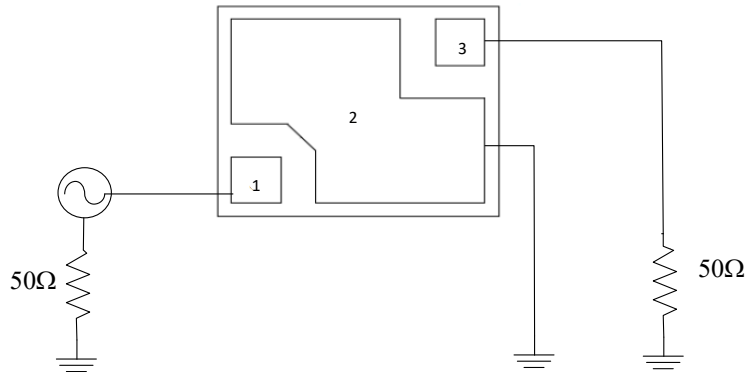
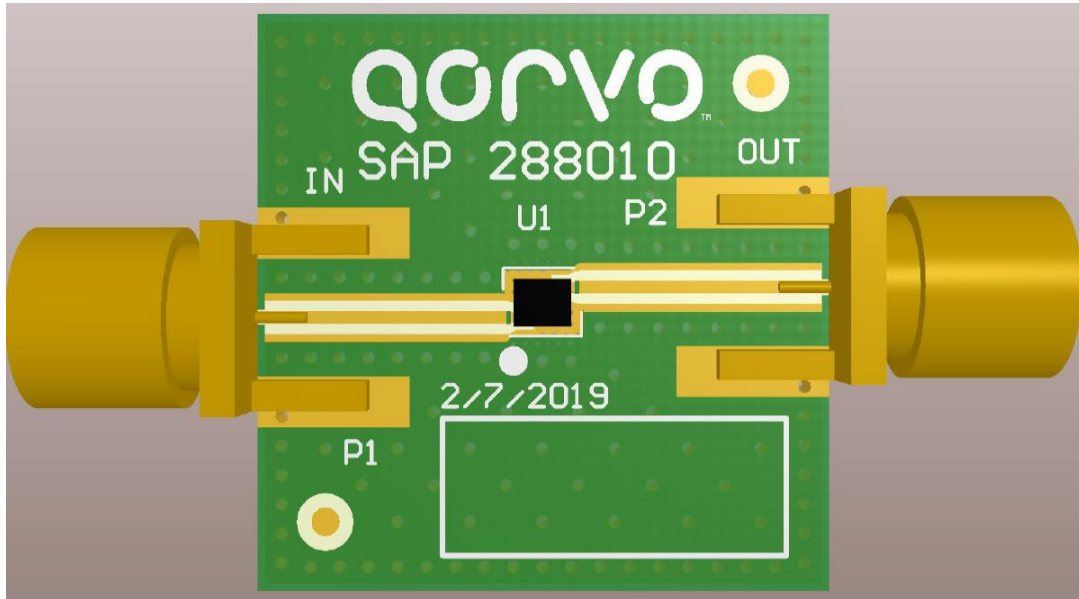

Bill of Material – QPQ1298EVB

Reference Des.	Value	Description	Manuf.	Part Number
U1	n/a	B41 Sub-Band Band 160 MHz BAW Filter	Qorvo	QPQ1298
SMA	n/a	SMA Edge Connector	Various	
PCB	n/a	3-Layer	Various	

Performance Plots – Small Signal

Test conditions unless otherwise noted: Temp = +25 °C, 50 Ω system

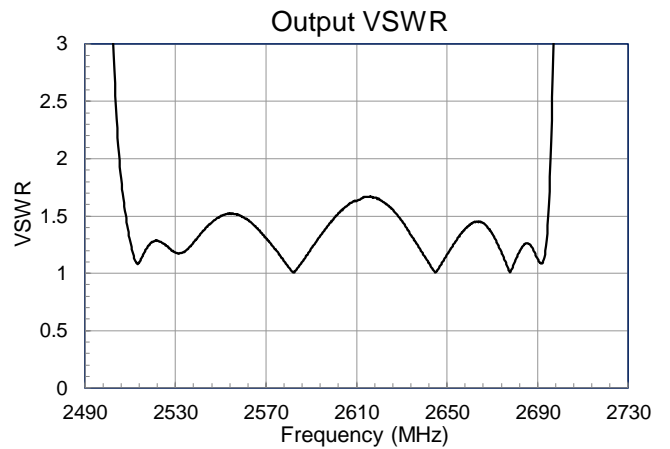
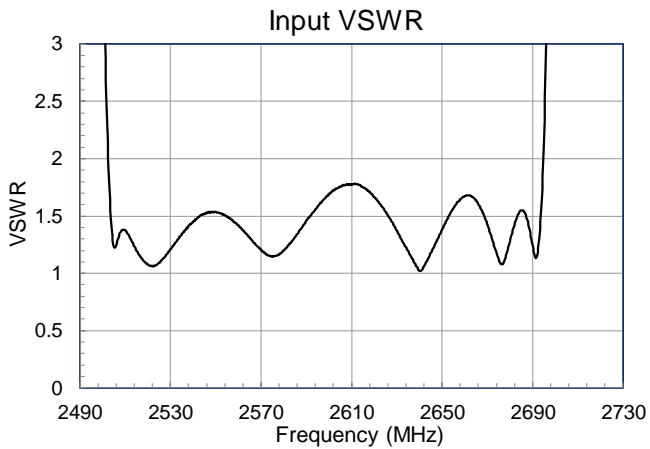
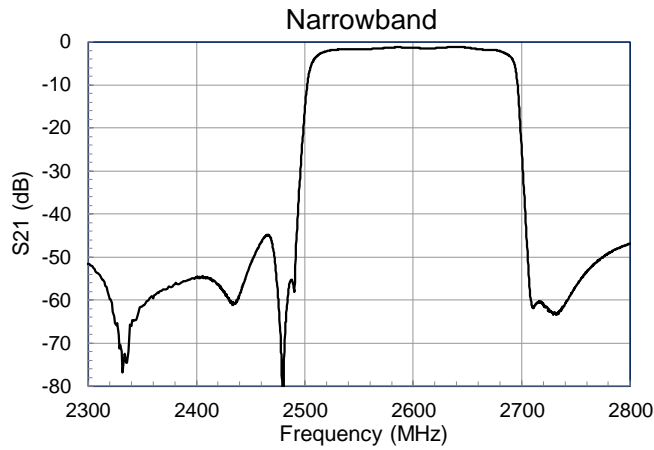
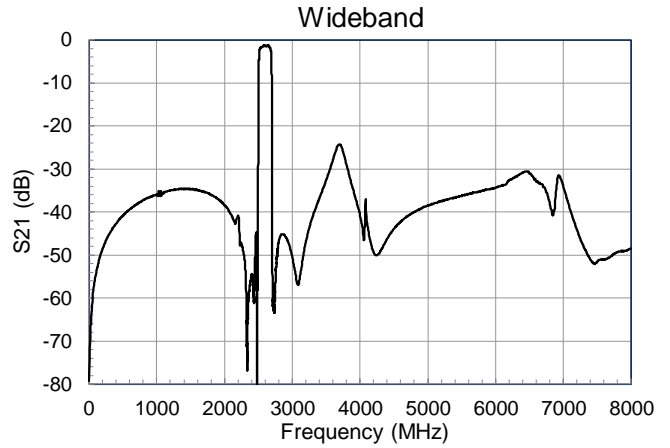
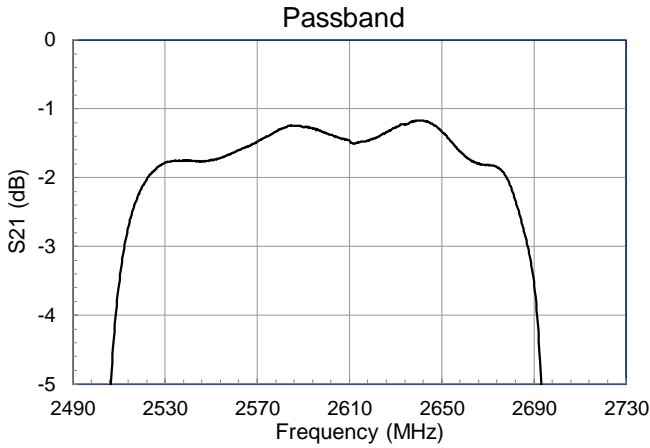

Package Marking and Dimensions

Marking:

YYYY indicates the Trace Code

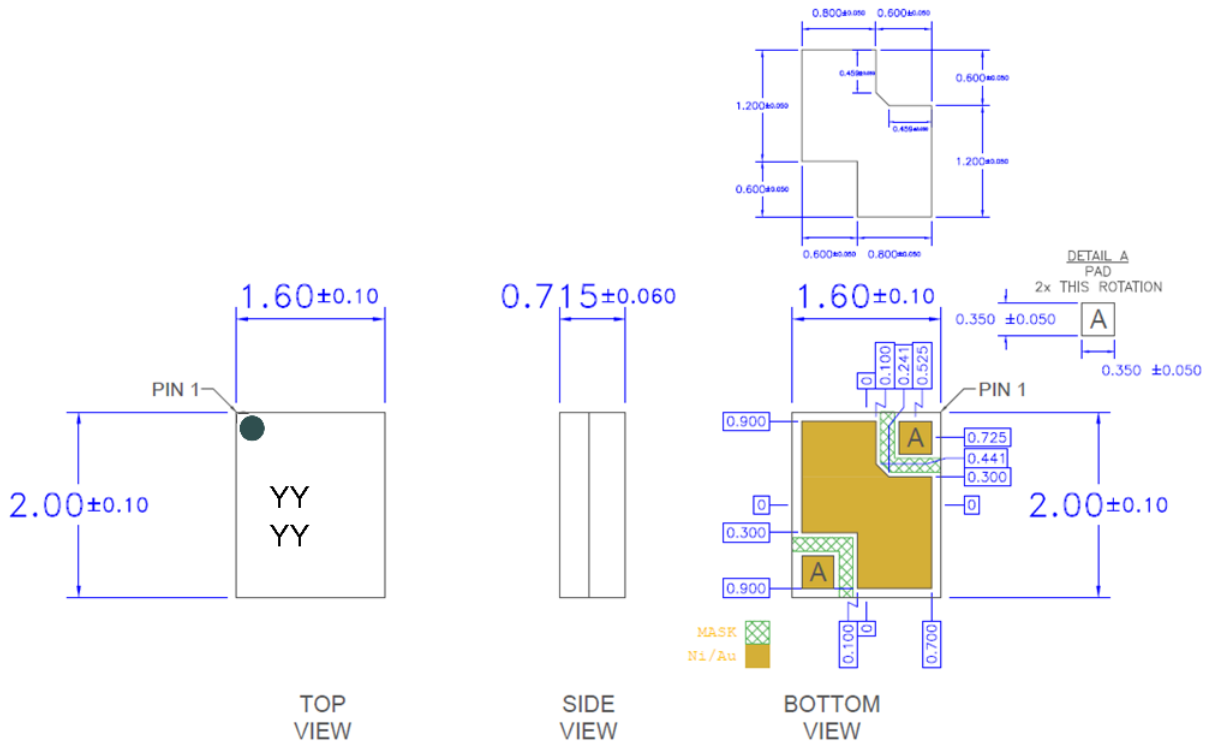

Notes:

1. All dimensions are in millimeters. Angles are in degrees.
2. Dimension and tolerance formats conform to ASME Y14.4M-1994.
3. The terminal #1 identifier and terminal numbering conform to JESD 95-1 SPP-012.

PCB Mounting Pattern

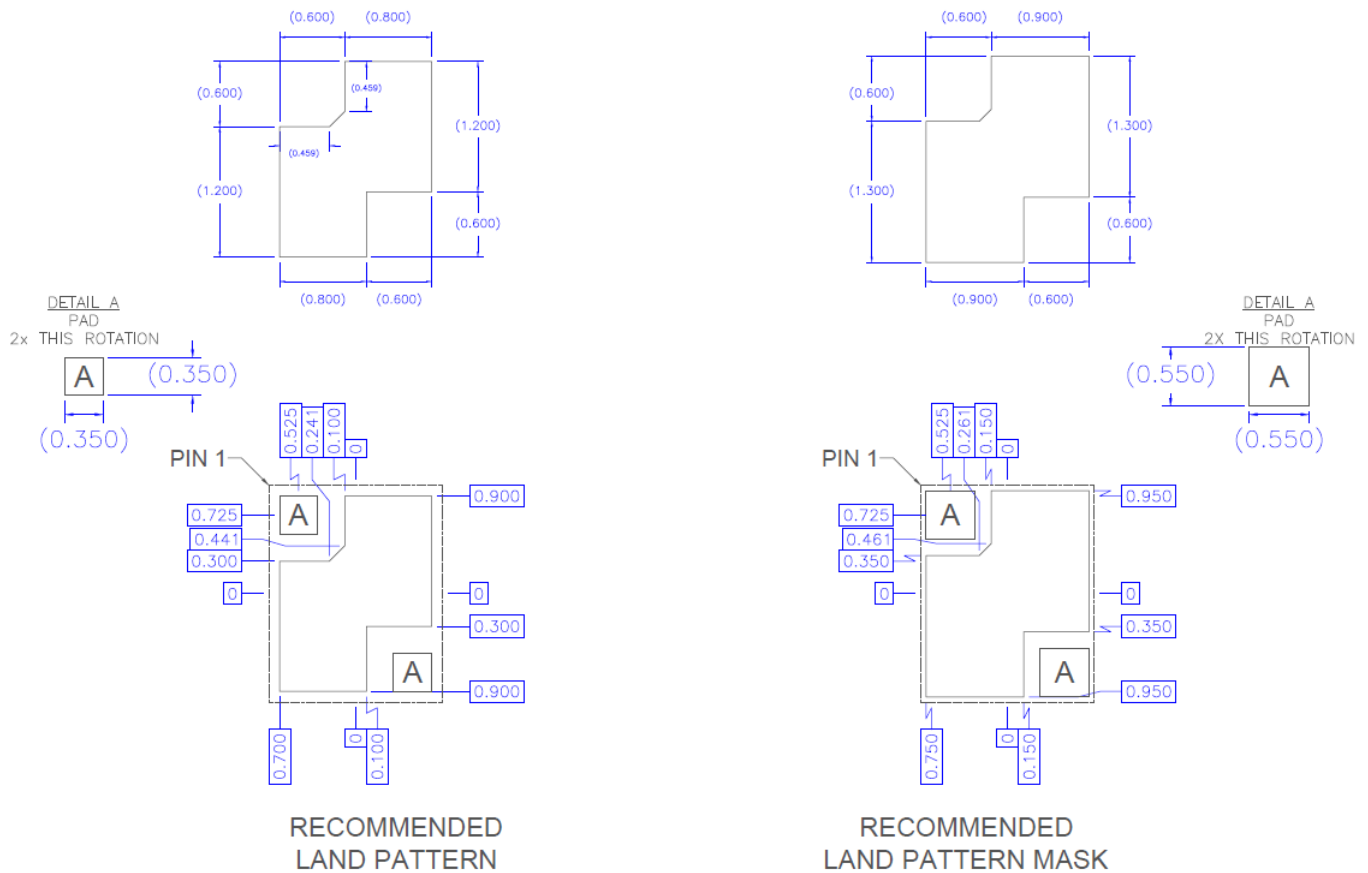

Notes:

1. All dimensions are in millimeters.
2. This drawing specifies the mounting pattern used on the Qorvo evaluation board for this product. Some modification may be necessary to suit end user assembly materials and processes

Tape and Reel Information – Carrier and Cover Tape Dimensions

Tape and reel specifications for this part are also available on the Qorvo website.
 Standard T/R size = 2500 pieces on a 7” reel.

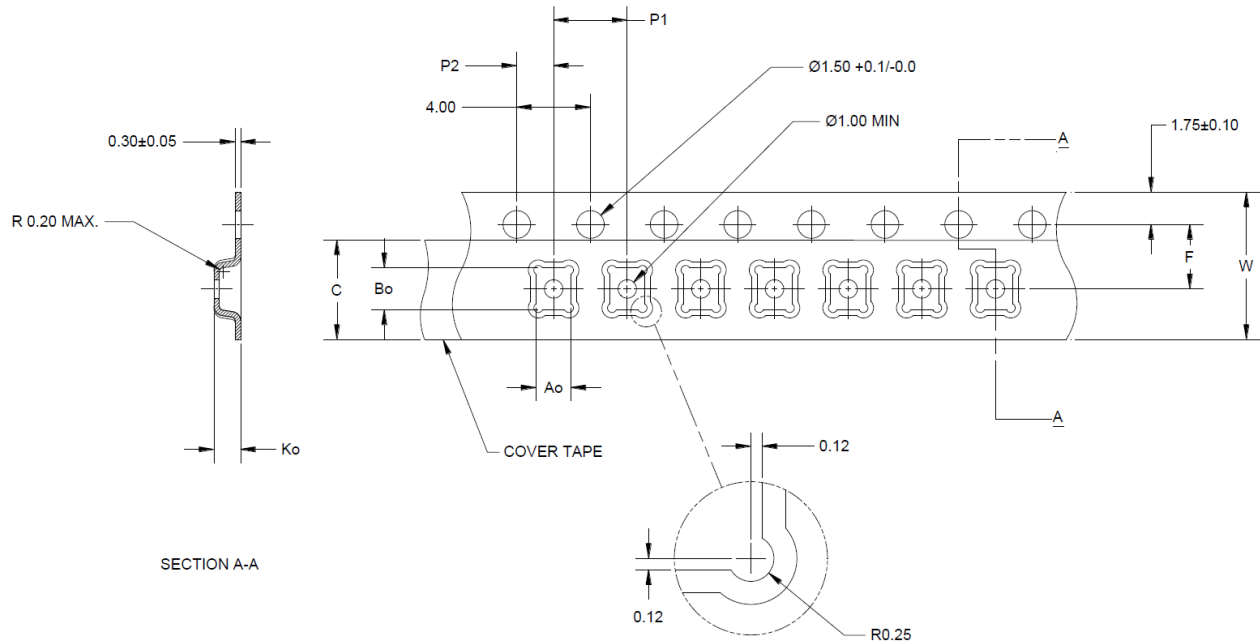

Feature	Measure	Symbol	Size (in)	Size (mm)
Cavity	Length	A0	0.077	1.95
	Width	B0	0.093	2.35
	Depth	K0	0.045	1.15
	Pitch	P1	0.157	4.00
Centerline Distance	Cavity to Perforation - Length Direction	P2	0.079	2.00
	Cavity to Perforation - Width Direction	F	0.138	3.50
Cover Tape	Width	C	0.213	5.40
Carrier Tape	Width	W	0.315	8.00

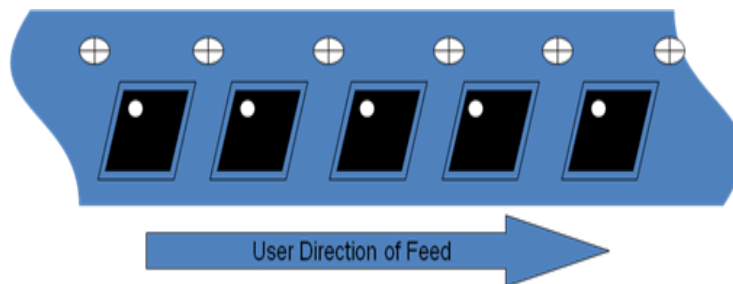

Tape and Reel Information – Reel Dimensions

Tape and reel specifications for this part are also available on the Qorvo website.
 Standard T/R size = 2500 pieces on a 7" reel.

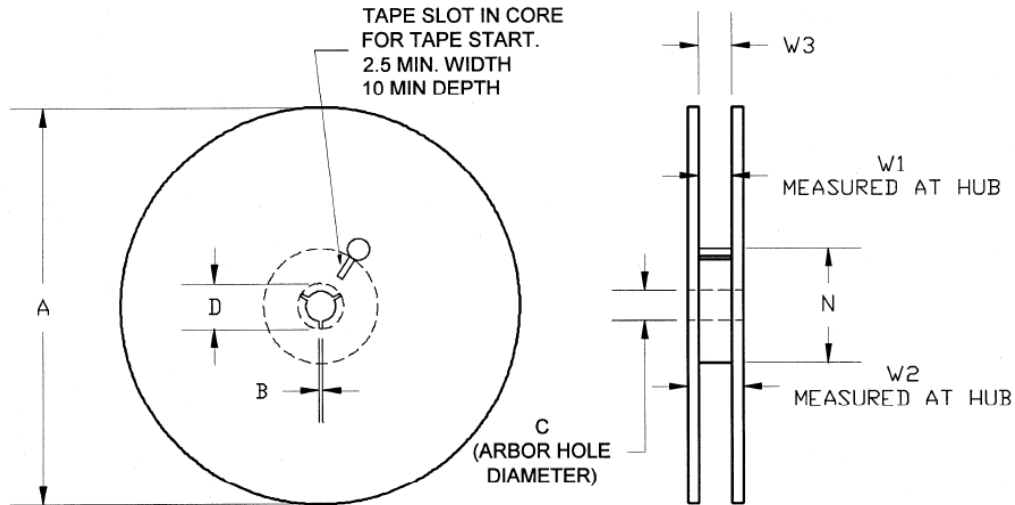

Feature	Measure	Symbol	Size (in)	Size (mm)
Flange	Diameter	A	6.969	177.0
	Thickness	W2	0.559	14.2
	Space Between Flange	W1	0.346	8.8
Hub	Outer Diameter	N	2.283	58.0
	Arbor Hole Diameter	C	0.512	13.0
	Key Slit Width	B	0.079	2.0
	Key Slit Diameter	D	0.787	20.0

Assembly Notes

Compatible with both lead-free (260°C peak reflow temperature) and tin/lead (245°C peak reflow temperature) soldering processes.

Contact plating: Ni-Au

Recommended Soldering Profile

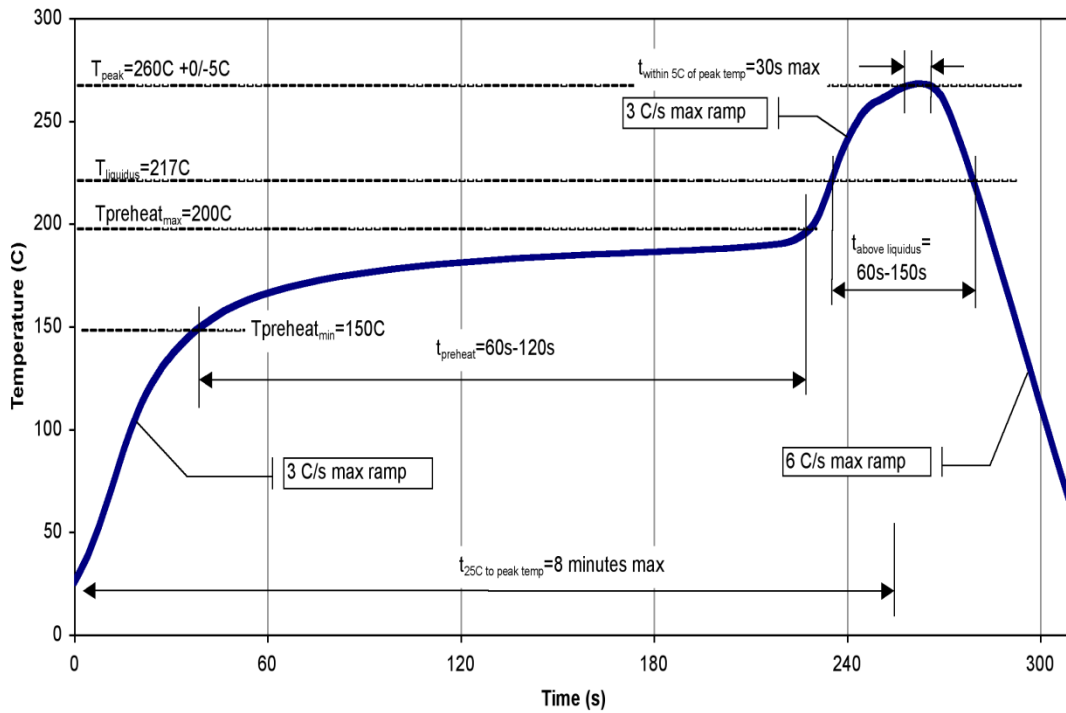

Handling Precautions

Parameter	Rating	Standard
ESD – Human Body Model (HBM)	1C	ANSI / ESD / JEDEC JS-001
ESD – Charged Device Model (CDM)	C3	ANSI / ESD / JEDEC JS-002
MSL – Moisture Sensitivity Level	Level 3	IPC/JEDEC J-STD-020



Caution!
ESD-Sensitive Device

RoHS Compliance

This product is compliant with the 2011/65/EU RoHS directive (Restrictions on the Use of Certain Hazardous Substances in Electrical and Electronic Equipment), as amended by Directive 2015/863/EU. This product also has the following attributes:

- Lead Free
- Halogen Free (Chlorine, Bromine)
- Antimony Free
- TBBP-A (C₁₅H₁₂Br₄O₂) Free
- PFOS Free
- SVHC Free

Contact Information

For the latest specifications, additional product information, worldwide sales and distribution locations:

Web: www.qorvo.com

Tel: 1-844-890-8163

Email: customer.support@qorvo.com

Important Notice

The information contained herein is believed to be reliable; however, Qorvo makes no warranties regarding the information contained herein and assumes no responsibility or liability whatsoever for the use of the information contained herein. All information contained herein is subject to change without notice. Customers should obtain and verify the latest relevant information before placing orders for Qorvo products. The information contained herein or any use of such information does not grant, explicitly or implicitly, to any party any patent rights, licenses, or any other intellectual property rights, whether with regard to such information itself or anything described by such information. **THIS INFORMATION DOES NOT CONSTITUTE A WARRANTY WITH RESPECT TO THE PRODUCTS DESCRIBED HEREIN, AND QORVO HEREBY DISCLAIMS ANY AND ALL WARRANTIES WITH RESPECT TO SUCH PRODUCTS WHETHER EXPRESS OR IMPLIED BY LAW, COURSE OF DEALING, COURSE OF PERFORMANCE, USAGE OF TRADE OR OTHERWISE, INCLUDING THE IMPLIED WARRANTIES OF MERCHANTABILITY AND FITNESS FOR A PARTICULAR PURPOSE.**

Without limiting the generality of the foregoing, Qorvo products are not warranted or authorized for use as critical components in medical, life-saving, or life-sustaining applications, or other applications where a failure would reasonably be expected to cause severe personal injury or death.

Copyright 2020 © Qorvo, Inc. | Qorvo is a registered trademark of Qorvo, Inc.

Mouser Electronics

Authorized Distributor

Click to View Pricing, Inventory, Delivery & Lifecycle Information:

Qorvo:

[QPQ1298TR7](#) [QPQ1298SR](#)