

## N-channel 75 V, 3 mΩ typ., 200 A STripFET™ F3 Power MOSFET in a PowerSO-10 package

Datasheet - production data

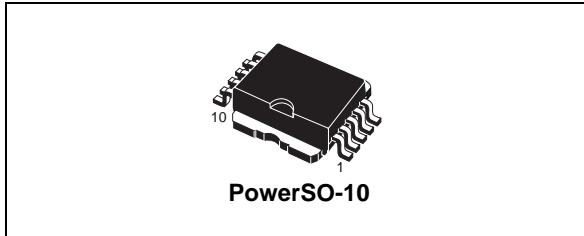

**Figure 1. Internal schematic diagram**

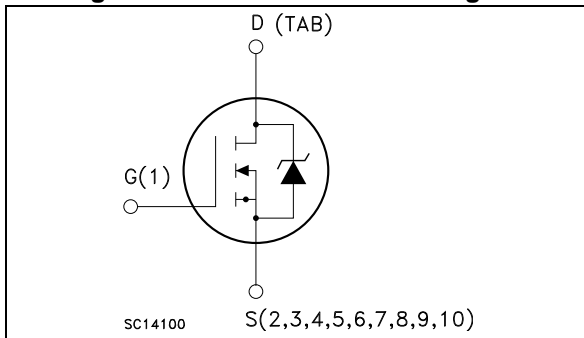

**Figure 2. Connection diagram (top view)**

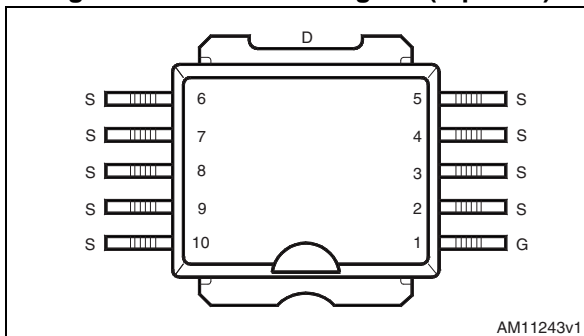

### Features

Order code	V <sub>DS</sub>	R <sub>DS(on)</sub> max	I <sub>D</sub>
STV240N75F3	75 V	3.3 mΩ	200 A

- Conduction losses reduced
- Low profile, very low parasitic inductance

### Applications

- Switching applications

### Description

This device is an N-channel Power MOSFET developed using STripFET™ F3 technology. It is designed to minimize on-resistance and gate charge to provide superior switching performance.

**Table 1. Device summary**

Order code	Marking	Package	Packaging
STV240N75F3	240N75F3	PowerSO-10	Tape and reel

# Contents

<b>1</b>	<b>Electrical ratings</b> .....	<b>3</b>
<b>2</b>	<b>Electrical characteristics</b> .....	<b>4</b>
	2.1 Electrical characteristics (curves) .....	6
<b>3</b>	<b>Test circuits</b> .....	<b>8</b>
<b>4</b>	<b>Package mechanical data</b> .....	<b>9</b>
<b>5</b>	<b>Packaging mechanical data</b> .....	<b>11</b>
<b>6</b>	<b>Revision history</b> .....	<b>13</b>

# 1 Electrical ratings

**Table 2. Absolute maximum ratings**

Symbol	Parameter	Value	Unit
$V_{DS}$	Drain-source voltage	75	V
$V_{GS}$	Gate-source voltage	$\pm 20$	V
$I_D^{(1)}$	Drain current (continuous) at $T_C = 25\text{ }^\circ\text{C}$	200	A
$I_D^{(1)}$	Drain current (continuous) at $T_C = 100\text{ }^\circ\text{C}$	170	A
$I_{DM}^{(2)}$	Drain current (pulsed)	800	A
$P_{TOT}$	Total dissipation at $T_C = 25\text{ }^\circ\text{C}$	300	W
	Derating factor	2.0	W/ $^\circ\text{C}$
$E_{AS}^{(3)}$	Single pulse avalanche energy	600	mJ
$T_{stg}$	Storage temperature	-55 to 175	$^\circ\text{C}$
$T_j$	Operating junction temperature		$^\circ\text{C}$

1. Current limited by package
2. Pulse width limited by safe operating area
3. Starting  $T_j = 25\text{ }^\circ\text{C}$ ,  $I_D = 60\text{ A}$ ,  $V_{DD} = 15\text{ V}$

**Table 3. Thermal data**

Symbol	Parameter	Value	Unit
$R_{thj-case}$	Thermal resistance junction-case max	0.5	$^\circ\text{C}/\text{W}$
$R_{thj-pcb}^{(1)}$	Thermal resistance junction-pcb max	35	$^\circ\text{C}/\text{W}$

1. When mounted on 1 inch<sup>2</sup> FR-4 2 oz Cu.

## 2 Electrical characteristics

( $T_{CASE} = 25\text{ °C}$  unless otherwise specified)

**Table 4. On /off states**

Symbol	Parameter	Test conditions	Min.	Typ.	Max.	Unit
$V_{(BR)DSS}$	Drain-source breakdown voltage	$I_D = 1\text{ mA}, V_{GS} = 0$	75			V
$I_{DSS}$	Zero gate voltage drain current ( $V_{GS} = 0$ )	$V_{DS} = 75\text{ V},$ $V_{DS} = 75\text{ V}, T_C = 125\text{ °C}$			10 100	$\mu\text{A}$ $\mu\text{A}$
$I_{GSS}$	Gate body leakage current ( $V_{DS} = 0$ )	$V_{GS} = \pm 20\text{ V}$			$\pm 200$	nA
$V_{GS(th)}$	Gate threshold voltage	$V_{DS} = V_{GS}, I_D = 250\text{ }\mu\text{A}$	2		4	V
$R_{DS(on)}$	Static drain-source on- resistance	$V_{GS} = 10\text{ V}, I_D = 120\text{ A}$		3	3.3	m $\Omega$

**Table 5. Dynamic**

Symbol	Parameter	Test conditions	Min.	Typ.	Max.	Unit
$C_{iss}$	Input capacitance	$V_{DS} = 25\text{ V}, f = 1\text{ MHz}, V_{GS} = 0$	-	6800	-	pF
$C_{oss}$	Output capacitance		-	1100	-	pF
$C_{rss}$	Reverse transfer capacitance		-	50	-	pF
$Q_g$	Total gate charge	$V_{DD} = 37.5\text{ V}, I_D = 120\text{ A},$ $V_{GS} = 10\text{ V}$ (see <a href="#">Figure 15</a> )	-	85	-	nC
$Q_{gs}$	Gate-source charge		-	30	-	nC
$Q_{gd}$	Gate-drain charge		-	26	-	nC

**Table 6. Switching times**

Symbol	Parameter	Test conditions	Min.	Typ.	Max	Unit
$t_{d(on)}$	Turn-on delay time	$V_{DD} = 37.5\text{ V}, I_D = 60\text{ A}$ $R_G = 4.7\text{ }\Omega, V_{GS} = 10\text{ V},$ (see <a href="#">Figure 14</a> and <a href="#">Figure 19</a> )	-	25	-	ns
$t_r$	Rise time		-	70	-	ns
$t_{d(off)}$	Turn-off delay time		-	100	-	ns
$t_f$	Fall time		-	15	-	ns

Table 7. Source drain diode

Symbol	Parameter	Test conditions	Min.	Typ.	Max.	Unit
$I_{SD}^{(1)}$	Source-drain current		-		200	A
$I_{SD}^{(2)}$	Source-drain current (pulsed)		-		800	A
$V_{SD}^{(3)}$	Forward on voltage	$I_{SD} = 120 \text{ A}, V_{GS} = 0$	-		1.5	V
$t_{rr}$	Reverse recovery time	$I_{SD} = 120 \text{ A}, di/dt = 100 \text{ A}/\mu\text{s}$ $V_{DD} = 20 \text{ V}, T_j = 150 \text{ }^\circ\text{C}$	-	80		ns
$Q_{rr}$	Reverse recovery charge		-	180		nC
$I_{RRM}$	Reverse recovery current		-	4.5		A

1. Current limited by package
2. Pulse width limited by safe operating area
3. Pulsed: Pulse duration = 300  $\mu\text{s}$ , duty cycle 1.5%

## 2.1 Electrical characteristics (curves)

Figure 3. Safe operating area

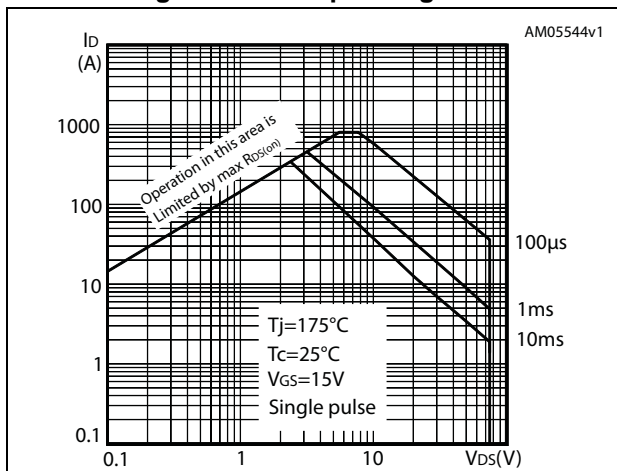

Figure 4. Thermal impedance

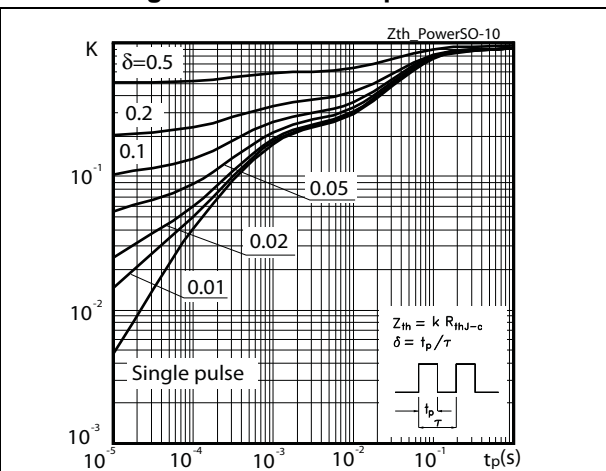

Figure 5. Output characteristics

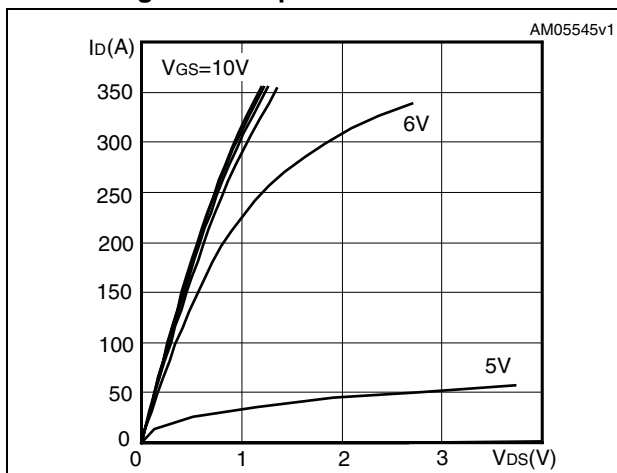

Figure 6. Transfer characteristics

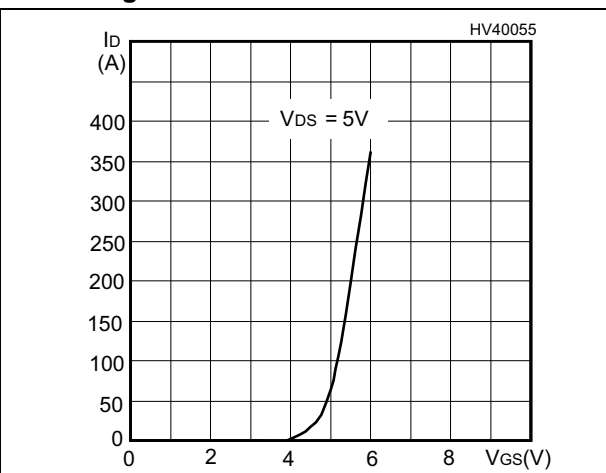

Figure 7. Normalized  $BV_{DSS}$  vs temperature

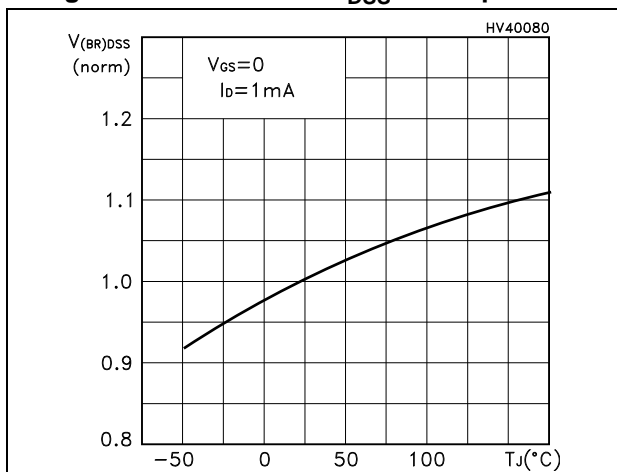

Figure 8. Static drain-source on-resistance

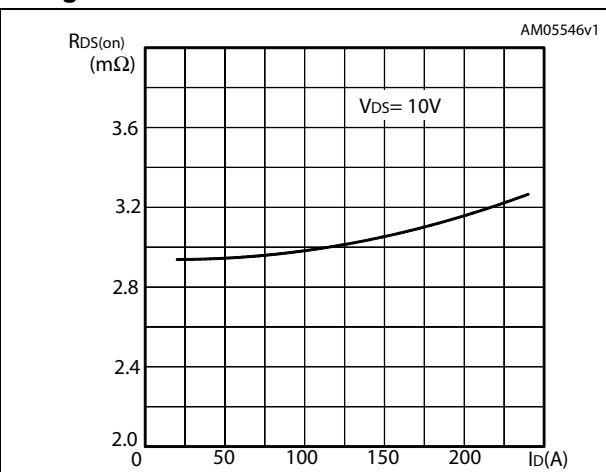

Figure 9. Gate charge vs gate-source voltage

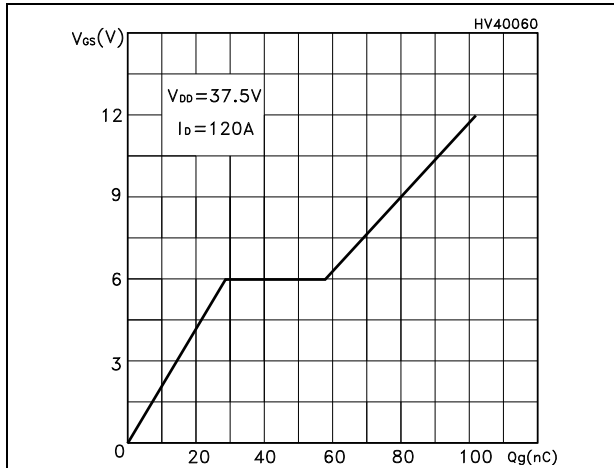

Figure 10. Capacitance variations

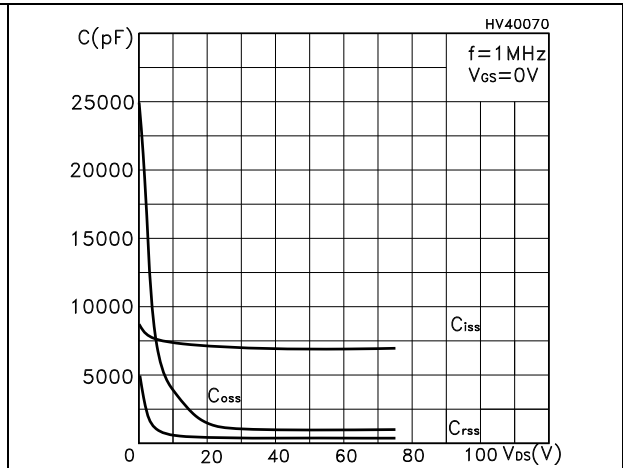

Figure 11. Normalized gate threshold voltage vs temperature

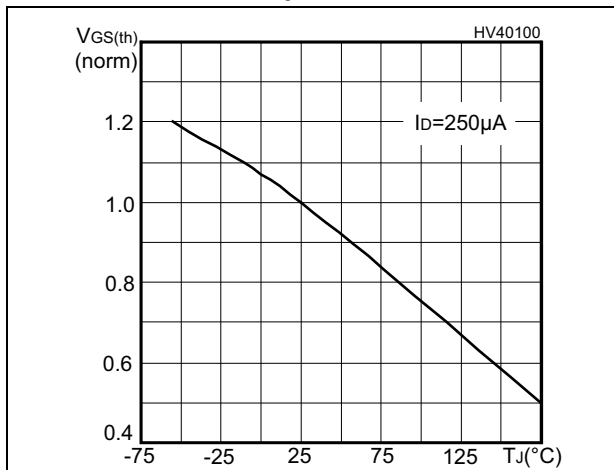

Figure 12. Normalized on-resistance vs temperature

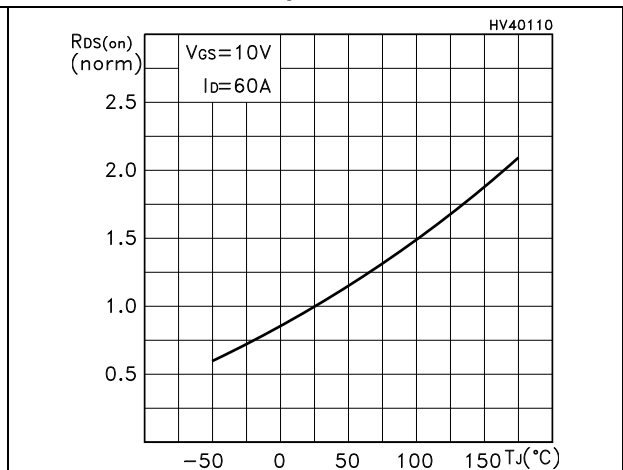
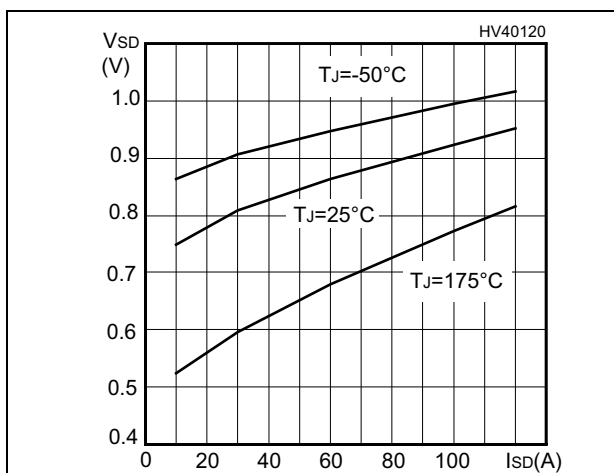

Figure 13. Source-drain diode forward characteristics



### 3 Test circuits

Figure 14. Switching times test circuit for resistive load

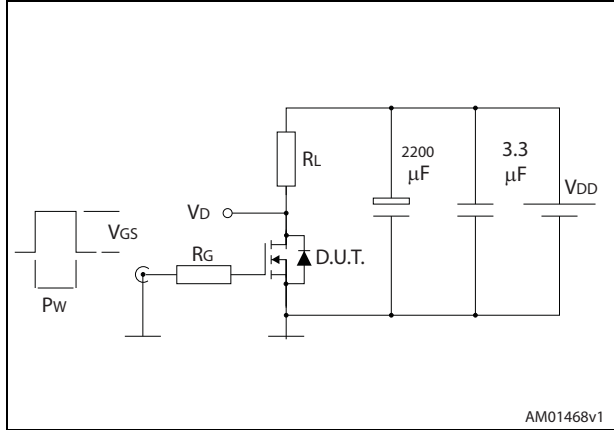

Figure 15. Gate charge test circuit

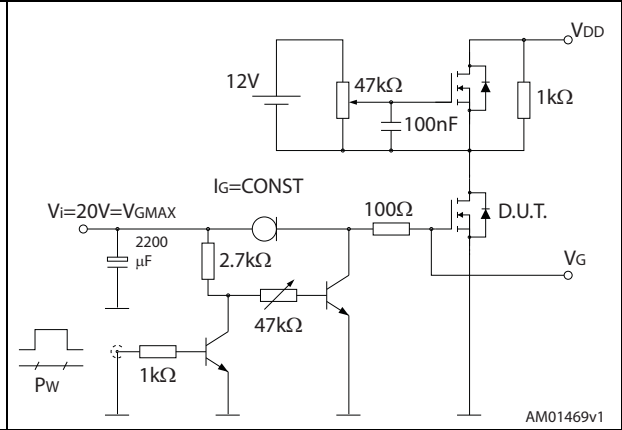

Figure 16. Test circuit for inductive load switching and diode recovery times

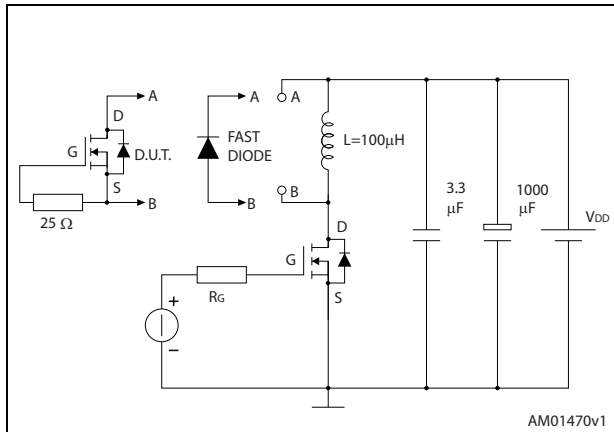

Figure 17. Unclamped inductive load test circuit

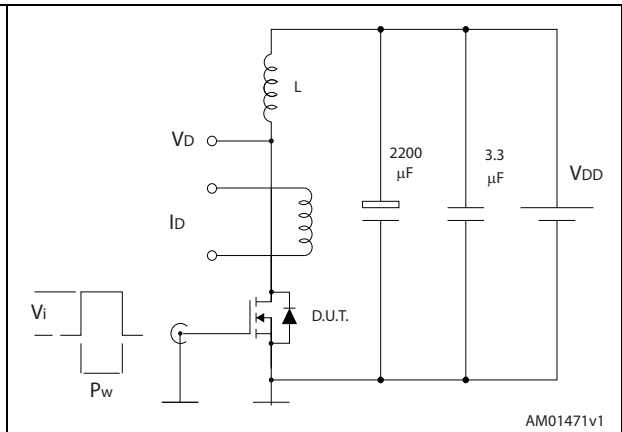

Figure 18. Unclamped inductive waveform

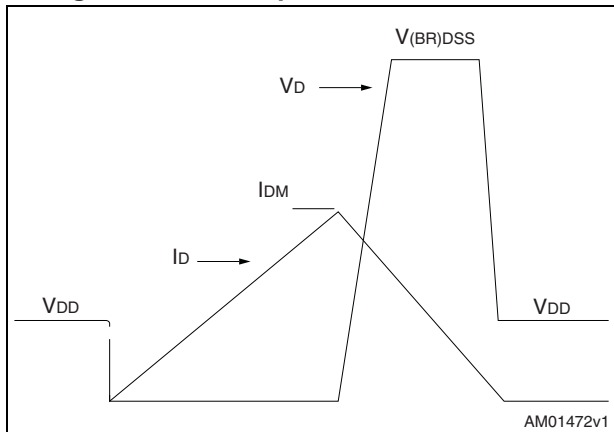
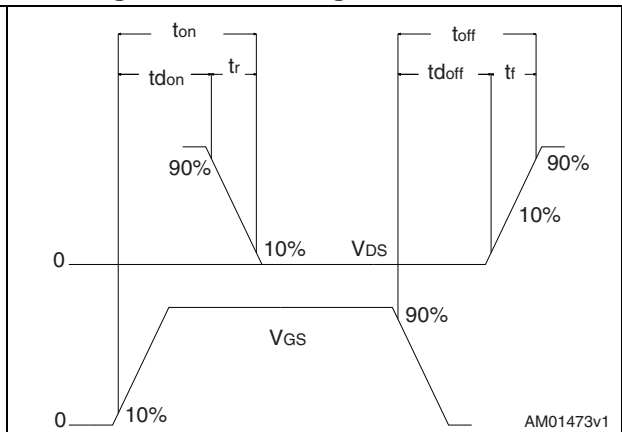

Figure 19. Switching time waveform





## 4 Package mechanical data

In order to meet environmental requirements, ST offers these devices in different grades of ECOPACK® packages, depending on their level of environmental compliance. ECOPACK® specifications, grade definitions and product status are available at: [www.st.com](http://www.st.com). ECOPACK is an ST trademark.

Figure 20. PowerSO-10 drawing

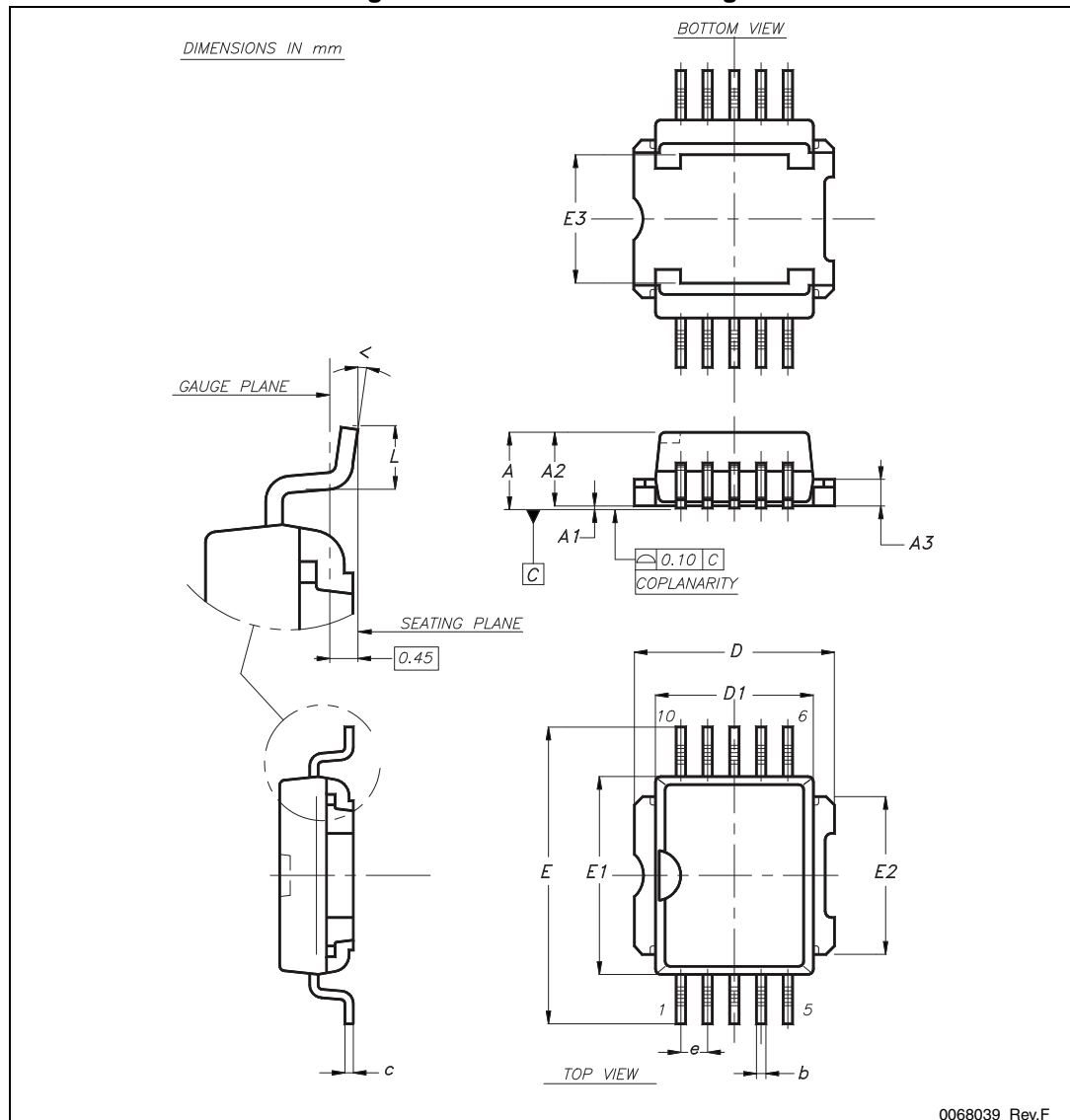
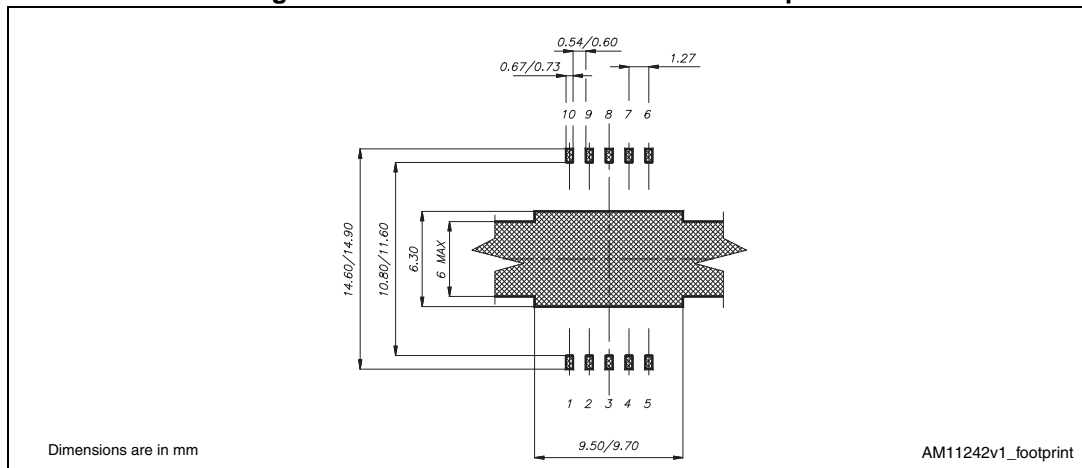

Table 8. PowerSO-10 mechanical data

Dim.	mm		
	Min.	Typ.	Max.
A			3.70
A1	0.00		0.10
A2	3.40		3.60
A3	1.25		1.35
b	0.40		0.53
c	0.35		0.55
D	9.40		9.60
D1 <sup>(1)</sup>	7.40		7.60
E	13.80		14.40
E1 <sup>(1)</sup>	9.30		9.50
E2	7.20		7.60
E3	5.90		6.10
e		1.27	
L	0.95		1.65
<	0°		8°

1. Resin protrusion not included (max value: 0.20 mm per side)

Figure 21. PowerSO-10 recommended footprint



## 5 Packaging mechanical data

Figure 22. Carrier tape drawing (a)

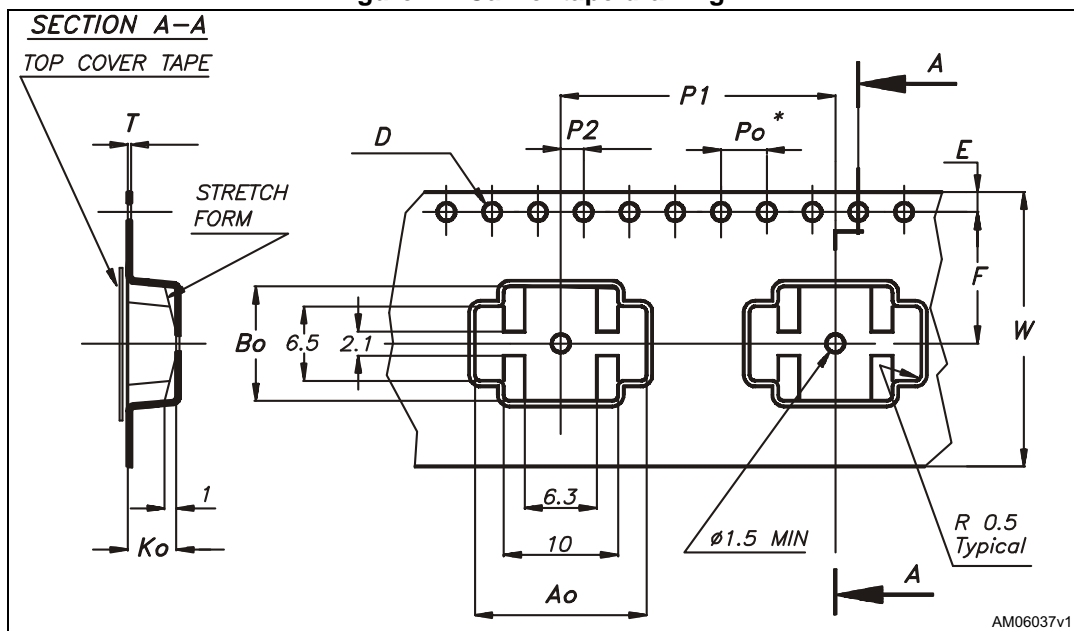

Table 9. Carrier tape dimensions

Ref.	mm		
	Min.	Typ.	Max.
A0	14.9	15.0	15.1
B0	9.9	10.0	10.1
K0	4.15	4.25	4.35
F	11.4	11.5	11.6
E	1.65	1.75	1.85
W	23.7	24.0	24.3
P2	1.9	2.0	2.1
P0	3.9	4.0	4.1
P1	23.9	24.0	24.1
T	0.025	0.30	0.35
D(Ø)	1.50	1.55	1.60

Note: 10 sprocket hole pitch cumulative tolerance  $\pm 0.2$  mm.

a. Drawing is not to scale.

Figure 23. Reel drawing (b)

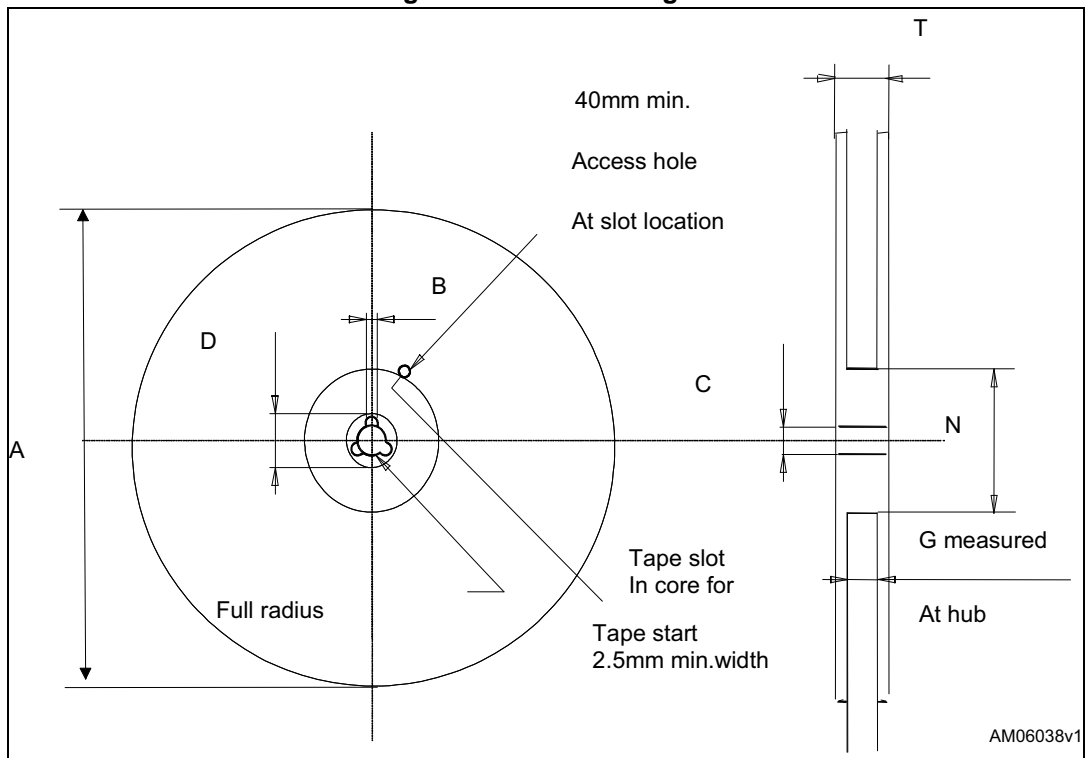

Table 10. Reel dimensions

Ref.	mm		
	Min.	Typ.	Max.
A			330
B	1.5		
C	12.8	13	13.2
D	20.2		
N	60		
G		24.4	
T			30.4

Note: 10 sprocket hole pitch cumulative tolerance  $\pm 0.2$  mm.

Table 11. Base/bulk quantities

Base qty.	Bulk qty.
600	

b. Drawing is not to scale.

## 6 Revision history

Table 12. Document revision history

Date	Revision	Changes
02-Apr-2008	1	Initial release
21-Jan-2010	2	– Document status promoted from preliminary data to datasheet. – Inserted new <a href="#">Section 5: Packaging mechanical data</a> .
4-May-2012	3	<a href="#">Section 4: Package mechanical data</a> has been updated: – <a href="#">Figure 21: PowerSO-10 recommended footprint</a> has been added. – Minor text changes.
27-Nov-2014	4	Updated title and description in cover page. Updated <a href="#">Figure 3: Safe operating area</a> and <a href="#">Figure 8: Static drain-source on-resistance</a> .

**IMPORTANT NOTICE – PLEASE READ CAREFULLY**

STMicroelectronics NV and its subsidiaries ("ST") reserve the right to make changes, corrections, enhancements, modifications, and improvements to ST products and/or to this document at any time without notice. Purchasers should obtain the latest relevant information on ST products before placing orders. ST products are sold pursuant to ST's terms and conditions of sale in place at the time of order acknowledgement.

Purchasers are solely responsible for the choice, selection, and use of ST products and ST assumes no liability for application assistance or the design of Purchasers' products.

No license, express or implied, to any intellectual property right is granted by ST herein.

Resale of ST products with provisions different from the information set forth herein shall void any warranty granted by ST for such product.

ST and the ST logo are trademarks of ST. All other product or service names are the property of their respective owners.

Information in this document supersedes and replaces information previously supplied in any prior versions of this document.

© 2014 STMicroelectronics – All rights reserved

# Mouser Electronics

Authorized Distributor

Click to View Pricing, Inventory, Delivery & Lifecycle Information:

[STMicroelectronics:](#)

[STV240N75F3](#)