



STMPE16M31PX

S-Touch[®] 16-channel touchkey controller with proximity sensing

Features

- Up to 16 capacitive sensor inputs
- Independent and configurable automatic calibration on all channels
- Proximity sensing capability for over 3 cm distance
- 15 fF resolution, 512 steps with 30 pF auto-tuning
- Up to 30 pF external reference capacitor
- PWM and GPIO:
 - Up to 16 general purpose inputs/outputs
 - 8 independent PWM controllers, up to 16 PWM outputs
 - 12 mA sourcing/sinking on GPIO for LED driving (at 3.3 V V_{IO})
 - Maximum source/sink current 120 mA
- Operating voltage:
 - 1.65 - 1.95 V (V_{CC} , internally supplied)
 - 2.7- 5.5 V (V_{IO})
- Low operating current: 300 μ A in active mode, 40 μ A in sleep mode and 5 μ A in hibernate mode
- I²C interface (up to 400 kHz). I²C is 3.3 V tolerant
- 8 kV HBM ESD protection on all sensing pins

Applications

- Multimedia bars in notebook computers
- Portable media players and game consoles
- Mobile phones and smartphones

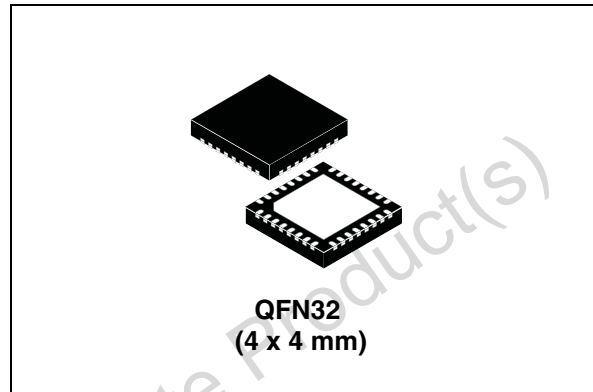

Description

The STMPE16M31PX capacitive touchkey controllers offer highly versatile and flexible capacitive sensing capabilities in one single chip.

The devices integrate up to 16 capacitive sensing channels which are highly sensitive and noise tolerant. Eight independent PWM controllers allow to control up to 16 LEDs with brightness control, ramping and blinking capabilities. The I²C interface supports up to 400 kHz communication with the system host. A very wide dynamic range allows most applications to work without hardware tuning.

A single STMPE16M31PX device can be used to implement a complete notebook multimedia control bar with eight capacitive touchkeys, proximity sensor with sensitivity up to 5 cm and eight independently controlled LED.

Table 1. Device summary

Order code	Package	Packaging
STMPE16M31PXQTR	QFN32 (4 x 4 mm)	Tape and reel

Contents

1	Pin assignment	4
1.1	Power scheme	9
1.2	Power states	9
2	I²C interface module	10
2.1	Device operation	10
3	Read operations	14
4	Write operations	15
4.1	Write operations for one or more bytes	15
5	General call address	16
6	Register map and function description	17
7	System controller	21
7.1	Interrupt system	25
8	Interrupt service routine	32
9	GPIO controller	33
10	PWM array controller	37
11	PWM controller	39
11.1	PWM function register map	39
12	Basic PWM programming	45
12.1	Interrupt on basic PWM controller	47
13	Touch sensor controller	48
13.1	Sampling rate calculation	49
13.2	Sensor resolution	50

13.3	Auto tuning	50
13.4	Locked impedance	52
13.5	Calibration	52
13.6	Definition of data accessible through channel data register	59
14	Touchkey and proximity sensing controller	60
15	Maximum rating	69
15.1	Recommended operating conditions	69
16	DC electrical characteristics	70
16.1	Capacitive sensor specification	71
17	Package mechanical data	72
18	Revision history	81

Obsolete Product(s) - Obsolete Product(s)

1 Pin assignment

Figure 1. STMPE16M31PX pin out

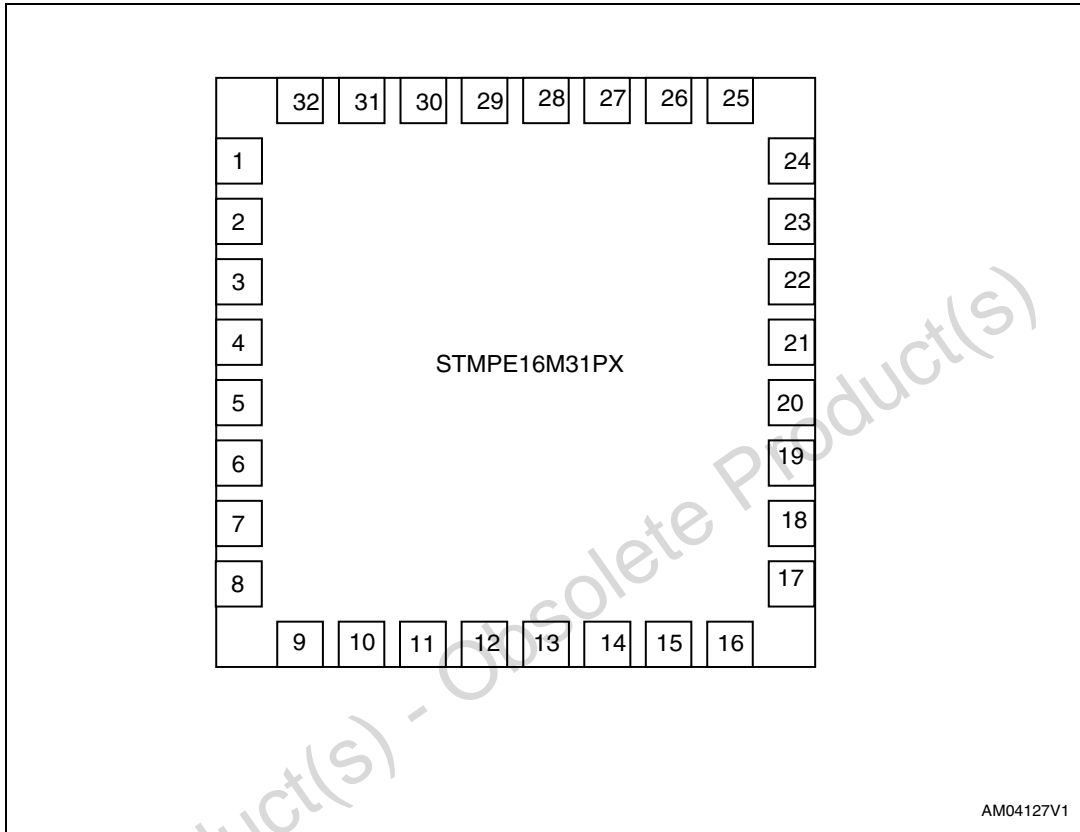

Table 2. STMPE16M31PX pin description

Pin number	Pin name	Voltage domain	Description
1	GPIO-0	VIO	GPIO / capacitive sense
2	GPIO-1	VIO	GPIO / capacitive sense
3	GPIO-2	VIO	GPIO / capacitive sense
4	GND	-	Ground
5	VIO	-	I/O supply
6	GPIO-3	VIO	GPIO / capacitive sense
7	GPIO-4	VIO	GPIO / capacitive sense
8	GPIO-5	VIO	GPIO / capacitive sense
9	GPIO-6	VIO	GPIO / capacitive sense
10	GPIO-7	VIO	GPIO / capacitive sense
11	GND	-	Ground
12	VIO	-	I/O supply
13	VCC	-	

Table 2. STMPE16M31PX pin description (continued)

Pin number	Pin name	Voltage domain	Description
14	INT	VCC	Open drain interrupt output. This pin should be pulled to VCC or GND, depending on polarity of interrupt used. This pin must not be left floating.
15	Address 0	VCC	I ² C address 0
16	SCL	VCC	I ² C clock
17	SDA	VCC	I ² C data
18	RESET_N	VCC	Active low reset signal
19	Address 1	VCC	I ² C address 1
20	CRef	VCC	Reference capacitor
21	GND	VCC	Ground
22	GPIO-8	VIO	GPIO / capacitive sense
23	GPIO-9	VIO	GPIO / capacitive sense
24	VIO	-	I/O supply
25	GPIO-10	VIO	GPIO / capacitive sense
26	GPIO-11	VIO	GPIO / capacitive sense
27	GPIO-12	VIO	GPIO / capacitive sense
28	GPIO-13	VIO	GPIO / cap sense
29	VIO	-	I/O supply
30	GND	-	I/O voltage supply
31	GPIO-14	VIO	GPIO / capacitive sense
32	GPIO-15	VIO	GPIO / capacitive sense

Figure 2. Block diagram

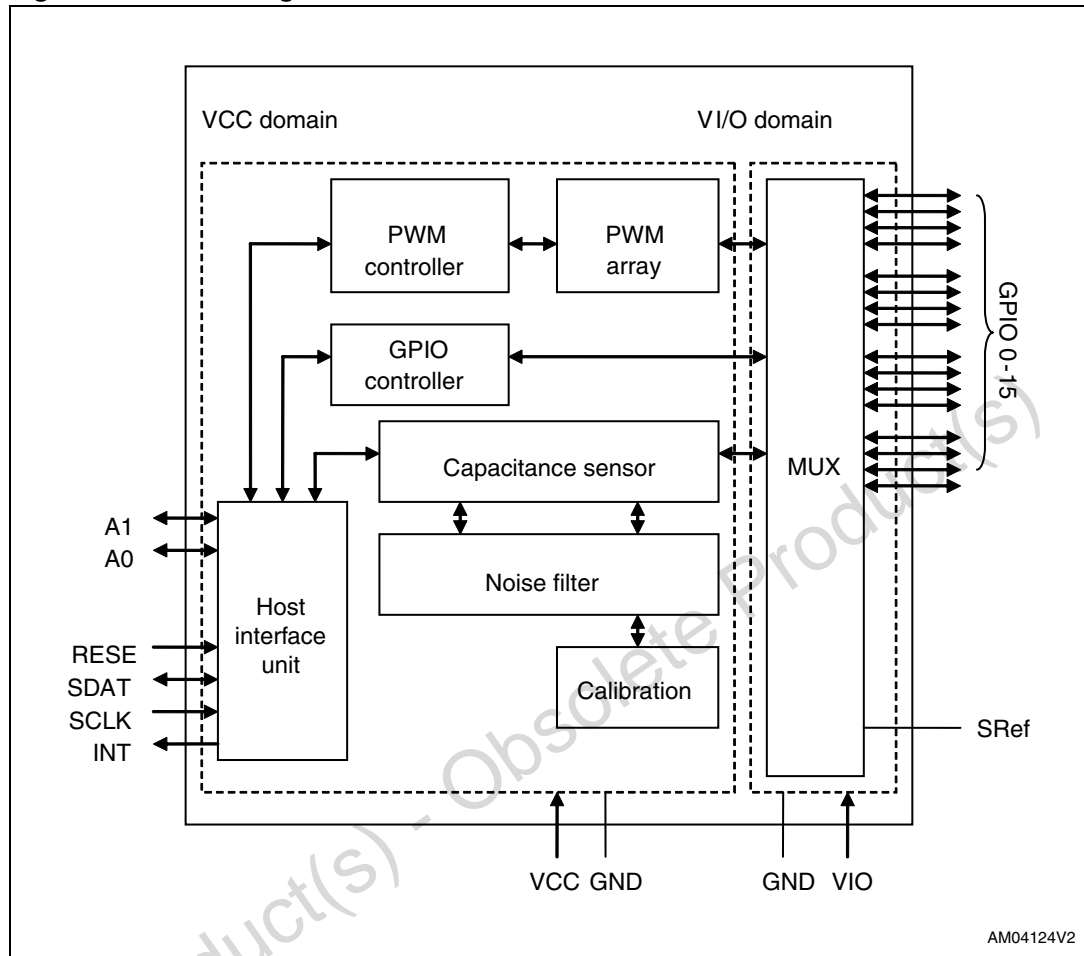

Figure 3. Sample application - notebook multimedia bar

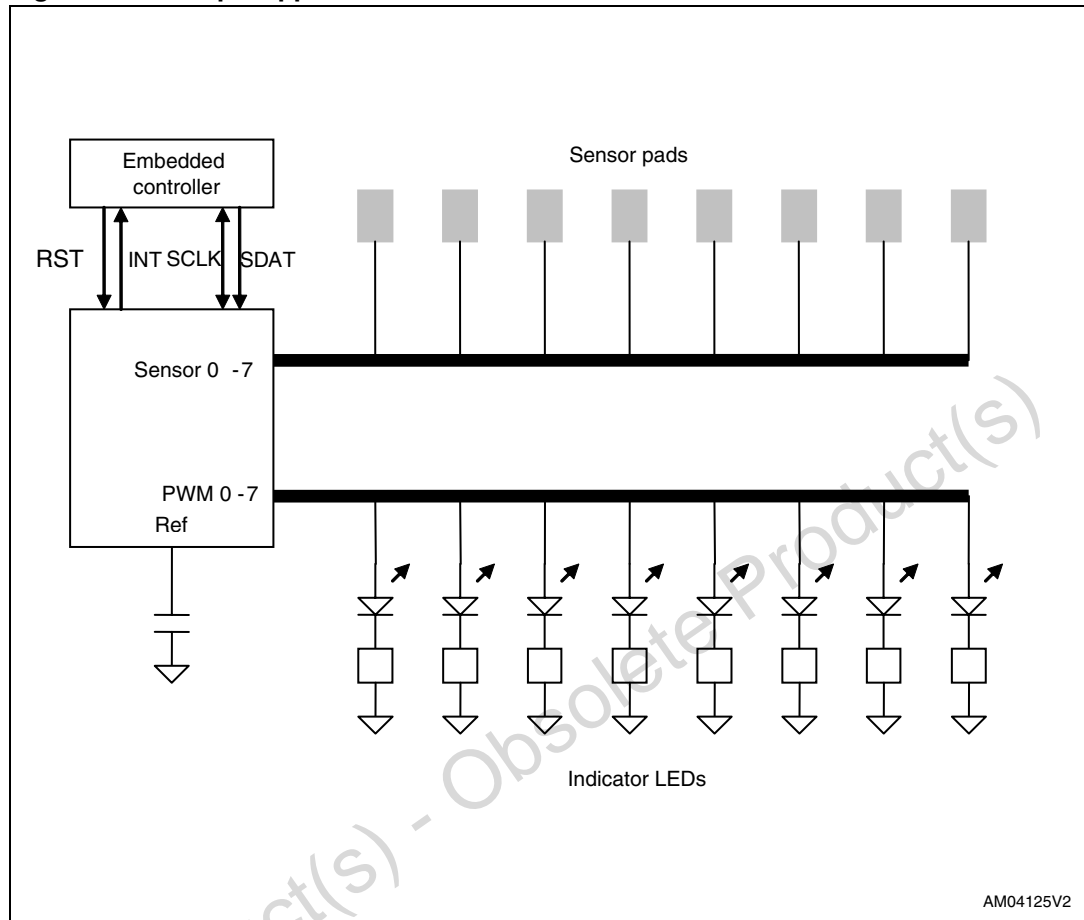

Table 3. Limitations on intrinsic capacitance on PCB / flexi PCB⁽¹⁾

C _{max} -C _{min} (Difference between highest and lowest channel capacitance)	C _{max}	Matching capacitors
< 30 pF	< 30 pF	Not required
< 30 pF	> 30 pF, < 60 pF	C _{ref} of up to 30 pF required
> 30 pF, < 60 pF	> 30 pF, < 60 pF	C _{ref} of up to 30 pF required Channel matching capacitance of up to 25 pF required
> 60 pF	> 60 pF	PCB optimization required

1. For small PCBs, it is possible to operate the device with C_{Ref} left unconnected. However, without a small capacitance at this pin, the capacitive sensing operation tends to be noisier. It is recommended that a capacitor of 10 pF to be connected to this pin.

1.1 Power scheme

The STMPE16M31PX is powered by a 2.7- 5.5 V supply. An internal voltage regulator regulates this supply into 1.8 V for core operation. It is recommended to connect a 1 μ F capacitor at V_{CC} pin for filtering purpose. The V_{IO} powers all GPIOs directly, if any LED driving is required on the GPIO, the V_{IO} should be at least 3.3 V.

Figure 4. Power supply scheme

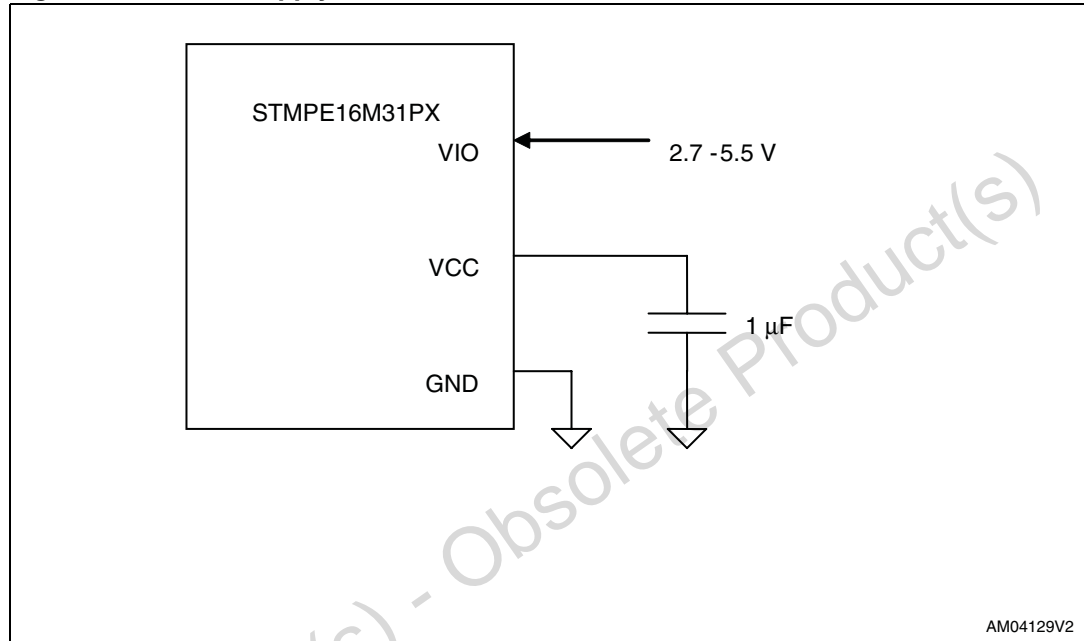

1.2 Power states

The STMPE16M31PX operate in 3 states. [Table 4](#) illustrates the capability of the device in each of the power states.

Table 4. Functions available in each power state

	Hibernate	Sleep	Active
I ² C	Yes	Yes	Yes
GPIO hotkey	Yes	Yes	Yes
PWM	No	Yes	Yes
Capacitive sensing	No	Slow	Yes
Proximity sensor	No	No	Yes

2 I²C interface module

The STMPE16M31PX has 2 physical I²C address pins, allowing 4 different I²C address settings.

Table 5. I²C address pins

Address 1	Address 0	I ² C address
0	0	0x58
0	1	0x59
1	0	0x5A
1	1	0x5B

The features that are supported by the I²C interface module are the following ones:

- I²C slave device
- Operates at V_{CC}
- Compliant to Philips I²C specification version 2.1
- Supports standard (up to 100 kbps) and fast (up to 400 kbps) modes
- 7-bit and 10-bit device addressing modes
- General call
- Start/restart/stop

The features that are not supported are:

- Hardware general call
- CBUS compatibility
- High-speed (3.4 Mbps) mode

2.1 Device operation

Start condition

A Start condition is identified by a falling edge of SDA while SCL is stable at high state. A Start condition must precede any data/command transfer. The device continuously monitors for a Start condition and does not respond to any transaction unless one is encountered.

Stop condition

A Stop condition is identified by a rising edge of SDA while SCL is stable at high state. A Stop condition terminates the communication between the slave device and bus master. A read command that is followed by NoAck can be followed by a Stop condition to force the slave device into idle mode. When the slave device is in idle mode, it is ready to receive the next I²C transaction. A Stop condition at the end of a write command stops the write operation to registers.

Acknowledge bit (ACK)

The acknowledge bit is used to indicate a successful byte transfer. The bus transmitter releases the SDA after sending eight bits of data. During the ninth bit, the receiver pulls the SDA low to acknowledge the receipt of the eight bits of data. The receiver may leave the SDA in high state if it would to *not* acknowledge the receipt of the data.

Data input

The device samples the data input on SDA on the rising edge of the SCL. The SDA signal must be stable during the rising edge of SCL and the SDA signal must change only when SCL is driven low.

Memory addressing

For the bus master to communicate to the slave device, the bus master must initiate a Start condition and be followed by the slave device address. Accompanying the slave device address, there is a Read/ \bar{W} bit (R/\bar{W}). The bit is set to 1 for Read and 0 for Write operation.

If a match occurs on the slave device address, the corresponding device gives an acknowledgement on the SDA during the 9th bit time. If there is no match, it deselects itself from the bus by not responding to the transaction. The register memory map of the device is 8-bit address width. Therefore, the maximum number of register is 256 registers of 8-bit width.

Table 6 illustrates the device operating modes that are supported.

Table 6. Device operation modes

Mode	Bytes	Initial sequence
Read	≥1	START, Device Address, R/\bar{W} =0, Base register Address to be read
		ReSTART, Device Address, R/\bar{W} =1, Data Read, STOP
		If no STOP is issued, the Data Read can be continuously preformed. The address is automatically incremented on subsequent data read.
Write	≥1	START, Device Address, R/\bar{W} =0, Register Address to be written, Data Write, STOP
		If no STOP is issued, the Data Write can be continuously performed. The address is automatically incremented on subsequent write.

Figure 5. Read and write modes (random and sequential)

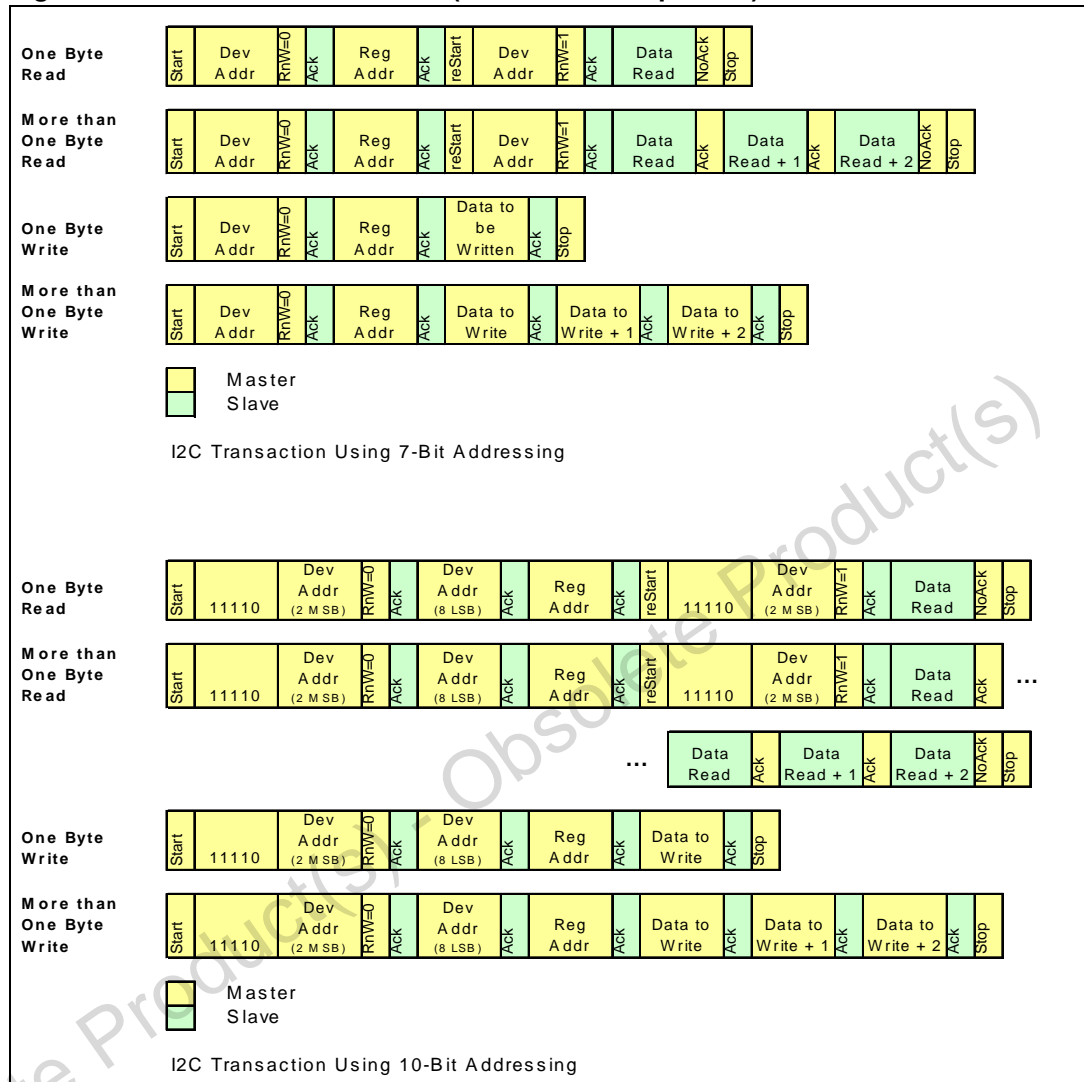
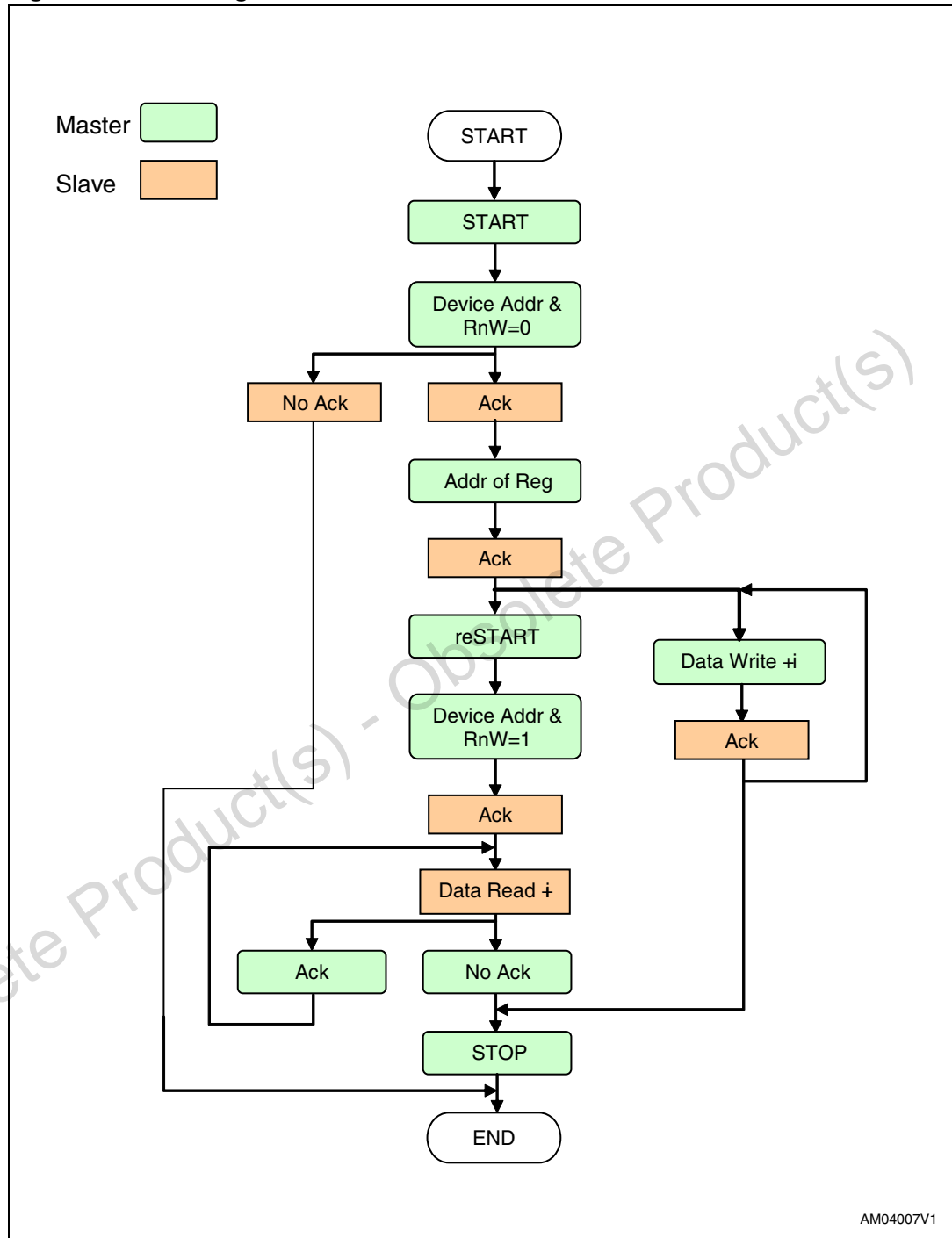

Figure 6. Flow diagram for read and write modes



3 Read operations

Read operations for one or more bytes

A write is first performed to load the base register address into the address counter but without sending a Stop condition. Then, the bus master sends a reStart condition and repeats the Device Address with the R/W bit set to 1. The slave device acknowledges and outputs the content of the addressed byte. If no more data is to be read, the bus master must not acknowledge the byte and terminates the transfer with a Stop condition.

If the bus master acknowledges the data byte, then it can continue to perform the data reading. To terminate the stream of data byte, the bus master must not acknowledge the last output byte and follow by a Stop condition. The data fetched are from consecutive addresses. After the last memory address, the Address Counter 'rolls-over' and the device continue to output data from the memory address of 0x00.

Acknowledgement in read operation

For the above read command, the slave device waits, after each byte read, for an acknowledgement during the 9th bit time. If the bus master does not drive the SDA to low state (no acknowledgement by the master), then the slave device terminates and switches back to its idle mode, waiting for the next command.

4 Write operations

4.1 Write operations for one or more bytes

A write is first performed to load the base register address into the Address Counter without sending a Stop condition. After the bus master receives an acknowledgement from the slave device, it may start to send a data byte to the register (pointed by the Address Counter). The slave device again acknowledges and the bus master terminates the transfer with a Stop condition.

If the bus master would like to continue to write more data, it can just continue write operation without issuing the Stop condition. After the bus master writes the last data byte and the slave device acknowledges the receipt of the last data, the bus master may terminate the write operation by sending a Stop condition. When the Address Counter reaches the last memory address, it 'rolls-over' on the next data byte write.

Obsolete Product(s) - Obsolete Product(s)

5 General call address

A general call address is a transaction with the slave address of 0x00 and $R/\overline{W} = 0$. When a general call address is made, the GPIO expander responds to this transaction with an acknowledgement and behaves as a slave-receiver mode. The meaning of a general call address is defined in the second byte sent by the master-transmitter.

Table 7. Definition of the second byte of the I²C transaction

R/ \overline{W}	Second byte value	Definition
0	0x06	2-byte transaction in which the second byte tells the slave device to perform a soft reset and write (or latch in) the 2-bit programmable part of the slave address.
0	0x04	2-byte transaction in which the second byte tells the slave device not to perform a soft reset and write (or latch in) the 2-bit programmable part of the slave address.
0	0x00	Not allowed as second byte.

Note: All other second byte values will be ignored.

Note: Please allow a gap of approximately 2 μ s gap before the next I2C transaction after the General Call of 0x04 or 0x06.

6 Register map and function description

This section lists and describes the registers of the STMPE16M31PX device, starting with a register map and then provides detailed descriptions of register types.

Table 8. Register map

Address	Register name	Reset value	I ² C	Register function
0x00	CHIP_ID	0x2431	R	CHIP identification number MSB: 0x24, LSB: 0x32
0x02	ID_VER	0x03	R	Version of device Engineering samples: 0x01, 0x02 Final silicon: 0x03
0x03	SYSCON-1	0x00	RW	General system control
0x04	SYSCON-2	0xFE	RW	Sensor and PWM clock divider
0x06	INT_CTRL	0x00	RW	Interrupt control
0x08	INT_STA	0x00	RW	Interrupt status
0x09	INT_EN	0x00	RW	Interrupt enable
0x0A	GPIO_INT_STA	0x0000	RW	Interrupt status GPIO
0x0C	GPIO_INT_EN	0x0000	RW	Interrupt enable GPIO
0x0E	PWM_INT_STA	0x00	RW	Interrupt status PWM
0x0F	PWM_INT_EN	0x00	RW	Interrupt enable PWM
0x10	GPIO_DIR	0x0000	RW	GPIO direction setting
0x12	GPIO_MP_STA	0x0000	R	GPIO pin state monitor
0x14	GPIO_SET_PIN	0x0000	RW	GPIO set pin state
0x16	GPIO_ALT_FUN	0x0000	RW	GPIO alternate function
0x20	GPIO_0_PWM_CFG	0x00	RW	Configures PWM output of GPIO-0
0x21	GPIO_1_PWM_CFG	0x00	RW	Configures PWM output of GPIO-1
0x22	GPIO_2_PWM_CFG	0x00	RW	Configures PWM output of GPIO-2
0x23	GPIO_3_PWM_CFG	0x00	RW	Configures PWM output of GPIO-3
0x24	GPIO_4_PWM_CFG	0x00	RW	Configures PWM output of GPIO-4
0x25	GPIO_5_PWM_CFG	0x00	RW	Configures PWM output of GPIO-5
0x26	GPIO_6_PWM_CFG	0x00	RW	Configures PWM output of GPIO-6

Table 8. Register map (continued)

Address	Register name	Reset value	I ² C	Register function
0x27	GPIO_7_PWM_CFG	0x00	RW	Configures PWM output of GPIO-7
0x28	GPIO_8_PWM_CFG	0x00	RW	Configures PWM output of GPIO-8
0x29	GPIO_9_PWM_CFG	0x00	RW	Configures PWM output of GPIO-9
0x2A	GPIO_10_PWM_CFG	0x00	RW	Configures PWM output of GPIO-10
0x2B	GPIO_11_PWM_CFG	0x00	RW	Configures PWM output of GPIO-11
0x2C	GPIO_12_PWM_CFG	0x00	RW	Configures PWM output of GPIO-12
0x2D	GPIO_13_PWM_CFG	0x00	RW	Configures PWM output of GPIO-13
0x2E	GPIO_14_PWM_CFG	0x00	RW	Configures PWM output of GPIO-14
0x2F	GPIO_15_PWM_CFG	0x00	RW	Configures PWM output of GPIO-15
0x30	PWM_MASTER_EN	0x00	RW	PWM master enable
0x40	PWM_0_SET	0x00	RW	PWM0 setup
0x41	PWM_0_CTRL	0x00	RW	PWM0 control
0x42	PWM_0_RAMP_RATE	0x00	RW	PWM0 ramp rate
0x43	PWM_0_TRIG	0x00	RW	PWM0 trigger
0x44	PWM_1_SET	0x00	RW	PWM1 setup
0x45	PWM_1_CTRL	0x00	RW	PWM1 control
0x46	PWM_1_RAMP_RATE	0x00	RW	PWM1 ramp rate
0x47	PWM_1_TRIG	0x00	RW	PWM1 trigger
0x48	PWM_2_SET	0x00	RW	PWM2 setup
0x49	PWM_2_CTRL	0x00	RW	PWM2 control
0x4A	PWM_2_RAMP_RATE	0x00	RW	PWM2 ramp rate
0x4B	PWM_2_TRIG	0x00	RW	PWM2 trigger
0x4C	PWM_3_SET	0x00	RW	PWM3 setup
0x4D	PWM_3_CTRL	0x00	RW	PWM3 control
0x4E	PWM_3_RAMP_RATE	0x00	RW	PWM3 ramp rate
0x4F	PWM_3_TRIG	0x00	RW	PWM3 trigger
0x50	PWM_4_SET	0x00	RW	PWM4 setup
0x51	PWM_4_CTRL	0x00	RW	PWM4 control
0x52	PWM_4_RAMP_RATE	0x00	RW	PWM4 ramp rate

Table 8. Register map (continued)

Address	Register name	Reset value	I ² C	Register function
0x53	PWM_4_TRIG	0x00	R/W	PWM4 trigger
0x54	PWM_5_SET	0x00	R/W	PWM5 setup
0x55	PWM_5_CTRL	0x00	R/W	PWM5 control
0x56	PWM_5_RAMP_RATE	0x00	R/W	PWM5 ramp rate
0x57	PWM_5_TRIG	0x00	R/W	PWM5 trigger
0x58	PWM_6_SET	0x00	R/W	PWM6 setup
0x59	PWM_6_CTRL	0x00	R/W	PWM6 control
0x5A	PWM_6_RAMP_RATE	0x00	R/W	PWM6 ramp rate
0x5B	PWM_6_TRIG	0x00	R/W	PWM6 trigger
0x5C	PWM_7_SET	0x00	R/W	PWM7 setup
0x5D	PWM_7_CTRL	0x00	R/W	PWM7 control
0x5E	PWM_7_RAMP_RATE	0x00	R/W	PWM7 ramp rate
0x5F	PWM_7_TRIG	0x00	R/W	PWM7 trigger
0x70	CAP_SEN_CTRL	0x00	R/W	Capacitive sensor control
0x71	RATIO_ENG_REPT_CTRL	0x00	R/W	Ratio engine report control (only available in final silicon)
0x72	CH_SEL	0x00000000	R/W	Selects active capacitive channels
0x76	CAL_INT	0x00	R/W	10 ms – 64 s calibration interval
0x77	CAL_MOD	0x00	R/W	Selects calibration model
0x78	MAF_SET	0x00	R/W	Control of median averaging filter
0x7C	DATA_TYPE	0x00	R/W	Selects type of data available in channel data ports. 0x01: TVR 0x02: EVR 0x03: Channel delay 0x04: Impedance (13-bit) 0x05: Calibrated Impedance (13-bit) 0x06: Locked impedance (13-bit)
0x90	KEY_PROX_CTRL	0x00	R/W	General key filter control
0x92	KEY_FILT_GROUP-1	0x00000000	R/W	Define channels included in key filter group 1
0x96	PROX_CFG	0x00	R/W	proximity configuration register
0x97	PTVR	0x00	R/W	TVR used for proximity sensing
0x98	PEVR	0x00	R/W	EVR used for proximity sensing and forced proximity calibration

Table 8. Register map (continued)

Address	Register name	Reset value	I ² C	Register function
0xB1	PEPort1	0x00	R	Proximity data 1
0xB0	PEPort0	0x00	R	Proximity data 0
0x9A	KEY_FILT_DATA	0x00000000		Filtered touchkey data
0xB4	TOUCH_DET	0x00000000	R	Touch detection register (real time)
0xC0	CH_DATA-0	0x0000	R	Channel data according to data type setting
0xC2	CH_DATA-1	0x0000		
0xC4	CH_DATA-2	0x0000		
0xC6	CH_DATA-3	0x0000		
0xC8	CH_DATA-4	0x0000		
0xCA	CH_DATA-5	0x0000		
0xCC	CH_DATA-6	0x0000		
0xCE	CH_DATA-7	0x0000		
0xD0	CH_DATA-8	0x0000		
0xD2	CH_DATA-9	0x0000		
0xD4	CH_DATA-10	0x0000		
0xD6	CH_DATA-11	0x0000		
0xD8	CH_DATA-12	0x0000		
0xDA	CH_DATA-13	0x0000		
0xDC	CH_DATA-14	0x0000		
0xDE	CH_DATA-15	0x0000		
0xE0	CH_DATA-16	0x0000		

7 System controller

The system controller contains the registers that control the following functions:

- Device identification
- Version identification
- Power state management
- Clock speed management
- Clock gating to various modules

Table 9. System controller registers

Address	Register name	Reset value	R/W	Description
0x00	CHIP_ID	0x2432	R	CHIP identification number. MSB: 0x24, LSB: 0x32
0x02	ID_VER	0x03	R	Version of device
0x03	SYSCON-1	0x00	RW	General system control
0x04	SYSCON-2	0xFE	RW	Sensor and PWM clock divider

SYSCON-1

General system control

Address: 0x03

Type: R/W

Reset: 0x00

Description: The general system control register (SYSCON-1) controls the operation state and clock speed of the device.

7	6	5	4	3	2	1	0
RESERVED	RESERVED	RESERVED	CLKSPD	SLEEP_EN	Reserved	SOFT_RST	HIBRNT
RW	RW	RW	RW	RW	RW	RW	RW
1	1	1	1	1	1	1	0

- [7:5] RESERVED: Do not write to these bits. Reads '0'. Writing '1' to these bits may result in unpredictable behaviour.
- [4] CLKSPD: Selects the macro engine's speed.
 0: 2 MHz
 1: RESERVED
- [3] SLEEP_EN: Enable or disable the sleep mode. Under all operating conditions, this bit should be set to '0'.
 1: Enable the touch sensor's sleep mode
 0: Disable the touch sensor's sleep mode
- [2] RESERVED: Do not write to these bits. Reads '0'.
- [1] SOFT_RST: Soft reset.
 1: To perform soft reset.
- [0] HIBRNT: Hibernate.
 1: To force the device to hibernate mode.

SYSCON-2**Sensor and PWM clock divider****Address:** 0x04**Type:** R/W**Reset:** 0xFE**Description:** Sensor and PWM clock divider. The SYSCON-2 register controls the sensor and PWM clock speed, and the clock gating of various functional modules.

This bit will always read '0'. as the I2C transaction to read this bit will wake up the device from hibernate mode.

7	6	5	4	3	2	1	0
SCLK_DIV			PCLK_DIV		GPIO_CLK	PWM_CLK	CS_CLK
RW			RW		RW		RW
1			1		1		0

[7:5] SCLK_DIV: Sensor clock divider.

000, 001: RESERVED

010 : 32 (to be used only if load capacitance is < 30 pF)

011: 64

100: 128

101: 256

110: 512

111: 1024

Sensor clock is $2 \text{ MHz} / (\text{PRBS_Factor} * \text{SCLK_DIV}[2:0])$

PRBS factor is a pseudo-random sequence of number, ranging from 1-8. This is used to reduce the effect of surrounding EMI on the sensor. Average of this factor is approximately 2.5

Effective sampling rate is $2 \text{ MHz} / (2.5 * \text{SCLK_DIV}[2:0])$.

Maximum total sampling rate : $2 \text{ MHz} / (2.5 * 64) = 12.5 \text{ kHz}$

Minimum total sampling rate : $2 \text{ MHz} / (2.5 * 1024) = 780 \text{ Hz}$

If N channel is active, the per-channel sampling rate is "total sampling rate / N".

Maximum channel sampling rate = $12.5 \text{ kHz} / 24 = 521 \text{ Hz}$

[4:3] PCLK_DIV: PWM clock divider

00 for 16 kHz

01 for 32 kHz

10 for 64 kHz

11 for 128 kHz

- [2] PMW_CLK: PWM clock disable
Write "1" to disable the clock to PWM module.
When clock to PWM module is disabled, access to PWM module register will not work correctly.
- [1] GPIO_CLK: GPIO clock disable
Write "1" to diWrite "1" to disable the clock to GPIO module.
When clock to GPIO module is disabled, access to GPIO module register will not work correctly.
- [0] CS_CLK: Capacitive sensor clock disable
Write "1" to disable the clock to capacitive sensor module
When clock to touch module is disabled, access to touch module registers will not work correctly.

Obsolete Product(s) - Obsolete Product(s)

7.1 Interrupt system

This module controls the interruption to the host based on the activity of other modules in the system, such as the capacitive sensing, GPIO and PWM modules.

Figure 7. Interrupt system

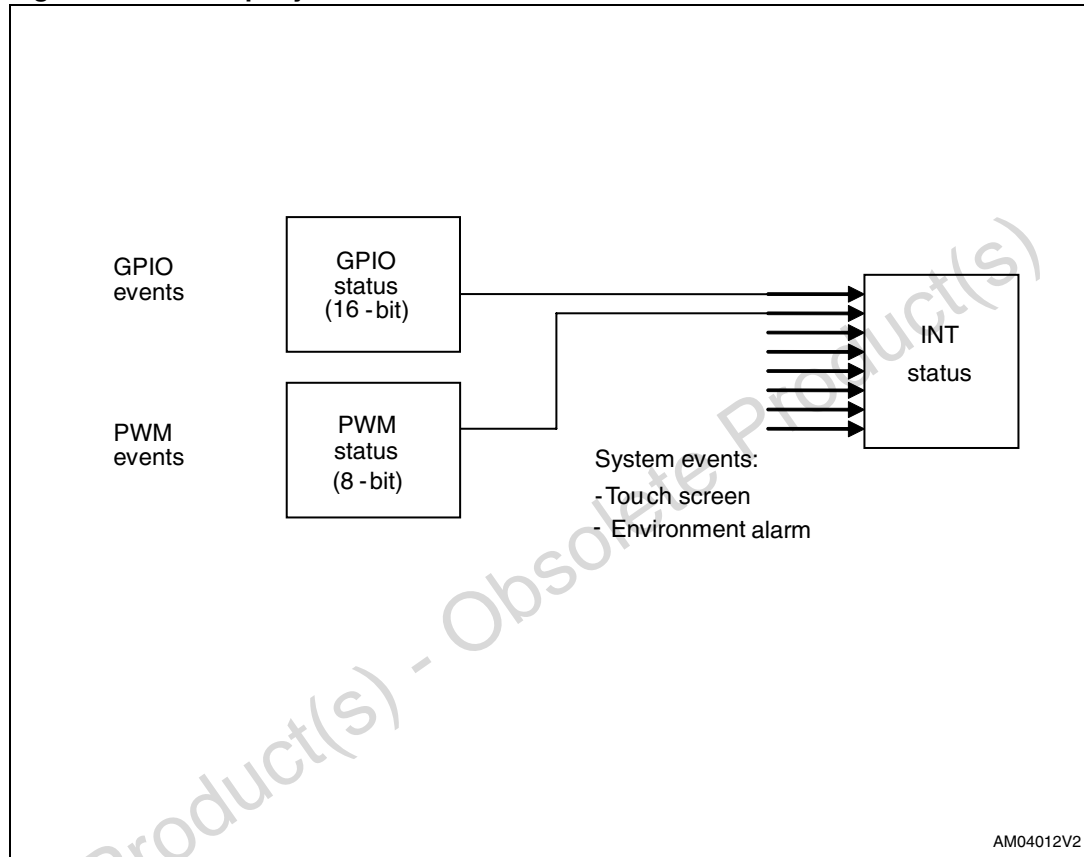

Table 10. Interrupt system registers

Address	Register name	Reset value	R/W	Description
0x06	INT_CTRL	0x00	RW	Interrupt control register
0x08	INT_STA	0x00	RW	Interrupt status register
0x09	INT_EN	0x00	RW	Interrupt enable register
0x0A	GPIO_INT_STA	0x0000	RW	Interrupt status GPIO register
0x0C	GPIO_INT_EN	0x0000	RW	Interrupt enable GPIO register
0x0E	PWM_INT_STA	0x00	RW	Interrupt status PWM register
0x0F	PWM_INT_EN	0x00	RW	Interrupt enable PWM register

INT_CTRL

Interrupt control register

Address: 0x06

Type: R/W

Reset: 0x00

Description: SYSCON3 controls the interrupt signal generation.

7	6	5	4	3	2	1	0
RESERVED					INT_POL	INT_TYPE	INT_EN
RW	RW	RW	RW	RW	RW	RW	RW
0	0	0	0	0	0	0	0

[7:3] RESERVED

[2] INT_POL: Interrupt polarity

0: Active low

1: Active high

[1] INT_TYPE: Interrupt trigger type

0: Level trigger

1: Edge trigger

[0] INT_EN: Interrupt enable

1: Enable the interrupt

0: Disable the interrupt

Obsolete Product(s) - Obsolete Product(s)

INT_STA**Interrupt status register****Address:** 0x08**Type:** R/W**Reset:** 0x00**Description:** This register holds interrupt status from each event.

7	6	5	4	3	2	1	0
GPIO	PWM	WAKEUP	ENV	EOC	TOUCH	PROX	RESERVED
RW	RW	RW	RW	RW	RW	RW	-
0	0	0	0	0	0	0	0

- [7] GPIO: Activity in GPIO
Read '1' if GPIO event occurs
Write '1' to clear the interrupt status
- [6] PWM: Any channel of PWM has completed the programmed sequence
Read '1' if PWM event occurs
Write '1' to clear the interrupt status
- [5] Device wake up from SLEEP or HIBERNATE mode
Read '1' if wake-up event occurs
Write '1' to clear the interrupt status
- [4] ENV: Possible drastic/abnormal environmental changes that requires attention from system software. This event includes 'calibration stuck' and 'tuning out of range'. If this bit is set, it is recommended that the host software initiates an unconditional calibration.
Read '1' if the events occur
Write '1' to clear the interrupt status
- [3] EOC: End of calibration
Read '1' if the host-triggered calibration has completed
Write '1' to clear the interrupt status
- [2] TOUCH: Touch-key event
Read '1' if touch is detected
Write '1' to clear the interrupt status
- [1] PROX: Proximity sensor event
Read '1' if proximity sensor detects an object
Write '1' to clear the interrupt status
- [0] RESERVED

INT_EN

Interrupt enable register

Address: 0x09
Type: R/W
Reset: 0x00
Description: Controls interrupt source enable.

7	6	5	4	3	2	1	0
GPIO	PWM	WAKEUP	ENV	EOC	TOUCH	PROX	RESERVED
RW	RW	RW	RW	RW	RW	RW	W
0	0	0	0	0	0	0	0

- [7] GPIO: Activity in GPIO
 Write '1' to enable interrupt signal from GPIO
 Write '0' to disable interrupt signal from GPIO
- [6] PWM: Any channel of PWM has completed the programmed sequence
 Write '1' to enable interrupt signal from PWM
 Write '0' to disable interrupt signal from PWM
- [5] Device wake up from SLEEP or HIBERNATE mode
 Read '1' if wake-up event occurs
 Write '1' to clear the interrupt status
- [4] ENV: Possible drastic/abnormal environmental changes that requires attention from system software. This event includes 'calibration stuck' and 'tuning out of range'
 Write '1' to enable interrupt signal from calibration/tuning event
 Write '0' to disable interrupt signal from calibration/tuning event
- [3] EOC: End of calibration
 Write '1' to enable interrupt signal from end of calibration event
 Write '0' to disable interrupt signal from end of calibration event
- [2] TOUCH: Touchkey event
 System should access touch detection register when this interrupt is received.
 Touch interrupt source needs to be enabled to activate key filter data.
 Write '1' to enable interrupt signal from touch event
 Write '0' to disable interrupt signal from touch event
- [1] PROX: Proximity sensor event
 Write '1' to enable interrupt signal from proximity sensor
- [0] RESERVED
 Write '0' to disable interrupt signal from proximity sensor

GPIO_INT_STA**Interrupt status GPIO register****Address:** 0x0A – 0x0B**Type:** R/W**Reset:** 0x0000

Description: This register reflects the status of GPIO that has been configured as input. When there is a change in GPIO state, the corresponding bit will be set to '1' by hardware. Writing '1' to the corresponding bit clears it. Writing '0' has no effect.

LSB (0x0A)

7	6	5	4	3	2	1	0
IO-7	IO-6	IO-5	IO-4	IO-3	IO-2	IO-1	IO-0
RW	RW	RW	RW	RW	RW	RW	RW
0	0	0	0	0	0	0	0

MSB (0x0B)

7	6	5	4	3	2	1	0
IO-15	IO-14	IO-13	IO-12	IO-11	IO-10	IO-9	IO-8
RW	RW	RW	RW	RW	RW	RW	RW
0	0	0	0	0	0	0	0

[7:0] IO - X: Interrupt status of GPIO - X

Read '1' if state transition is detected in corresponding GPIO channel

Write '1' to clear the interrupt status.

GPIO_INT_EN

Interrupt enable GPIO register

Address: 0x0C – 0x0D

Type: R/W

Reset: 0x0000

Description: This register is used to enable the generation of interrupt signal, at the INT pin.

LSB (0x0C)

7	6	5	4	3	2	1	0
IO-7	IO-6	IO-5	IO-4	IO-3	IO-2	IO-1	IO-0
RW	RW	RW	RW	RW	RW	RW	RW
0	0	0	0	0	0	0	0

MSB (0x0D)

7	6	5	4	3	2	1	0
IO-15	IO-14	IO-13	IO-12	IO-11	IO-10	IO-9	IO-8
RW	RW	RW	RW	RW	RW	RW	RW
0	0	0	0	0	0	0	0

[7:0] IO - X

Interrupt status of GPIO - X

Read '1' if state transition is detected in corresponding GPIO channel

Write '1' to clear the interrupt status.

PWM_INT_STA

Interrupt status PWM register

Address: 0x0E

Type: R/W

Reset: 0x00

Description: When a PWM controller completes the PWM sequence, the corresponding bit in this register goes to '1'. Write '1' in this register clears the written bit, writing '0' has no effect.

7	6	5	4	3	2	1	0
PWM-7	PWM-6	PWM-5	PWM-4	PWM-3	PWM-2	PWM-1	PWM-0
RW	RW	RW	RW	RW	RW	RW	RW
0	0	0	0	0	0	0	0

[7:0] PWM - X

Interrupt status of PWM - X.

Read '1' if the corresponding PWM channel complete programmed sequence

Write '1' to clear the interrupt status

PWM_INT_EN**Interrupt enable PWM enable register****Address:** 0x0F**Type:** R/W**Reset:** 0x00**Description:** Writing '1' to this register enables the generation of INT by the corresponding PWM channel.

7	6	5	4	3	2	1	0
PWM-7	PWM-6	PWM-5	PWM-4	PWM-3	PWM-2	PWM-1	PWM-0
RW	RW	RW	RW	RW	RW	RW	RW
0	0	0	0	0	0	0	0

[7:0] PWM - X

Enable of PWM – X.

Write '1' to the corresponding bit to enable interrupt generated by a PWM channel

8 Interrupt service routine

On receiving an interrupt, system software should:

Read InterruptStatus

```
If (GPIO.bit==1)
```

```
{
```

```
Read InterruptStatusGPIO
```

```
    Process GPIO INT
```

```
    Write InterruptStatusGPIO to clear the corresponding bit
```

```
Write InterruptStatus to clear the corresponding bit
```

```
}
```

```
If (PWM.bit==1)
```

```
{
```

```
Read InterruptStatusPWM
```

```
    Process PWM INT
```

```
    Write InterruptStatusPWM to clear the corresponding bit
```

```
Write InterruptStatus to clear the corresponding bit
```

```
}
```

```
If ( EV_ALARM or TOUCHSCREEN or TOUCHKEY)
```

```
{
```

```
    Process INT
```

```
    Write InterruptStatus to clear the corresponding bit
```

```
}
```

9 GPIO controller

A total of 16 GPIOs are available in the STMPE16M31PX. Most of the GPIOs are sharing physical pins with some alternate functions. The GPIO controller contains the registers that allow the host system to configure each of the pins into either a GPIO, or one of the alternate functions. Unused GPIOs should be configured as outputs to minimize the power consumption.

Table 11. GPIO controller registers

Address	Register name	Reset value	R/W	Description
0x10	GPDR	0X0000	R/W	GPIO direction register
0x12	GPMR	0X0000	R/W	GPOIO monitor pin state register
0x14	GPSR	0X0000	R/W	GPIO set pin register
0x16	GPFR	0X0000	R/W	GPIO alternate function register

GPIO_DIR

GPIO direction register

Address: 0x10 – 0x11

Type: RW

Reset: 0x00

Description: Direction setting of the GPIO.

LSB (0x10)

7	6	5	4	3	2	1	0
IO-7	IO-6	IO-5	IO-4	IO-3	IO-2	IO-1	IO-0
RW	RW	RW	RW	RW	RW	RW	RW
0	0	0	0	0	0	0	0

MSB (0x11)

7	6	5	4	3	2	1	0
IO-15	IO-14	IO-13	IO-12	IO-11	IO-10	IO-9	IO-8
RW	RW	RW	RW	RW	RW	RW	RW
0	0	0	0	0	0	0	0

[7:0] IO - X

Write '1' to a bit to set the corresponding I/O to output.

Write '0' to a bit to set the corresponding I/O to input.

GPIO_MP_STA**GPIO monitor pin state register****Address:** 0x12 – 0x13**Type:** R**Reset:** 0x00**Description:** Contains the state of all GPIO.**LSB (0x12)**

7	6	5	4	3	2	1	0
IO-7	IO-6	IO-5	IO-4	IO-3	IO-2	IO-1	IO-0
RW	RW	RW	RW	RW	RW	RW	RW
0	0	0	0	0	0	0	0

MSB (0x13)

7	6	5	4	3	2	1	0
IO-15	IO-14	IO-13	IO-12	IO-11	IO-10	IO-9	IO-8
RW	RW	RW	RW	RW	RW	RW	RW
0	0	0	0	0	0	0	0

[7:0] IO - X

Read '1' if the corresponding IO is in HIGH state

Read '0' if the corresponding IO is in LOW state

GPIO_SET_PIN**GPIO set pin state register**

Address: 0x14 – 0x15
Type: RW
Reset: 0x00
Description: Setting of the I/O output state.

LSB (0x14)

7	6	5	4	3	2	1	0
IO-7	IO-6	IO-5	IO-4	IO-3	IO-2	IO-1	IO-0
RW	RW	RW	RW	RW	RW	RW	RW
0	0	0	0	0	0	0	0

MSB (0x15)

7	6	5	4	3	2	1	0
IO-15	IO-14	IO-13	IO-12	IO-11	IO-10	IO-9	IO-8
RW	RW	RW	RW	RW	RW	RW	RW
0	0	0	0	0	0	0	0

[7:0] IO - X

Write '1' to set the corresponding IO output state to HIGH

Write '0' to set the corresponding IO output state to LOW

GPIO_AF

GPIO function register

Address: 0x16 – 0x17
Type: RW
Reset: 0x00
Description: Setting of the GPIO function.

LSB (0x16)

7	6	5	4	3	2	1	0
IO-7	IO-6	IO-5	IO-4	IO-3	IO-2	IO-1	IO-0
RW	RW	RW	RW	RW	RW	RW	RW
0	0	0	0	0	0	0	0

MSB (0x17)

7	6	5	4	3	2	1	0
IO-15	IO-14	IO-13	IO-12	IO-11	IO-10	IO-9	IO-8
RW	RW	RW	RW	RW	RW	RW	RW
0	0	0	0	0	0	0	0

[7:0] IO - X

Write '1' to set the corresponding GPIO to alternate function (IO)

Write '0' to set the corresponding GPIO to primary function (capacitive sensor)

10 PWM array controller

The STMPE16M31PX integrates 8 independent PWM controllers capable of blinking and brightness control.

Each of the PWM controllers can be programmed to execute a series of blinking/brightness control actions. One PWM controller could be mapped to more than one GPIO, allowing multiple GPIO outputs to share a PWM controller.

Each PWM controller can be connected to any of GPIO channel through the routing network which is controlled by GPIO_n_PWM_CFG register (n = GPIO channel number).

Figure 8. PWM array controller

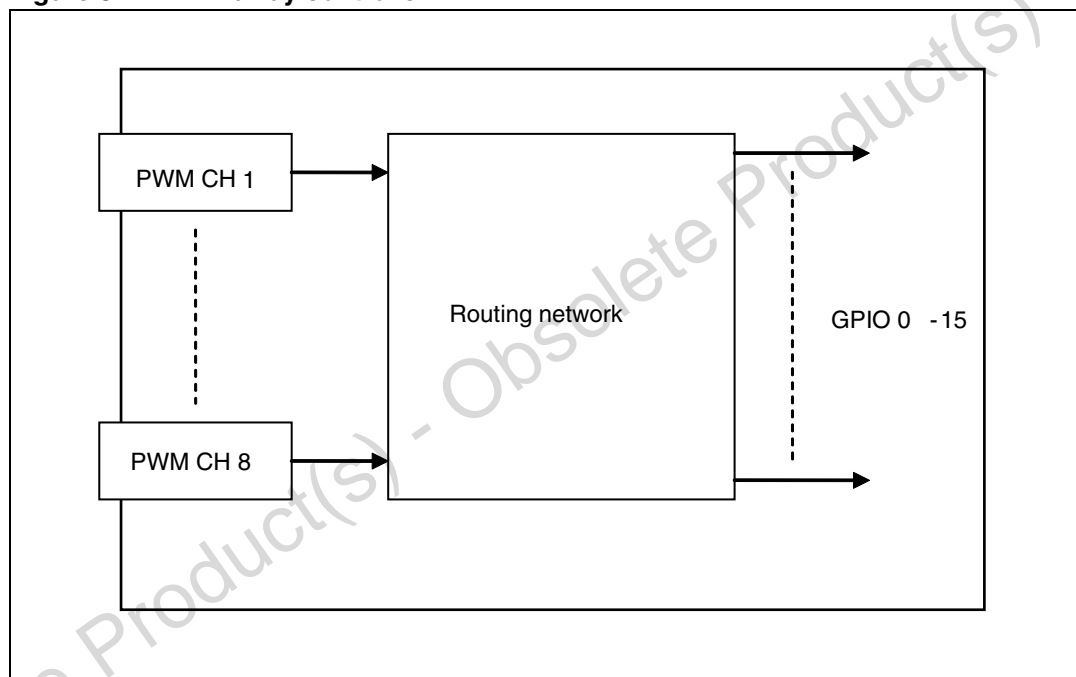

GPIO_PWM_CFG

PWM array controller

Address: 0x20-2F

Type: RW

Reset: 0x00

Description: This register controls the routing network which connects each PWM channel to any GPIO channel. GPIO_n_PWM_CFG register (n=0-15, represent the GPIO channel number)

7	6	5	4	3	2	1	0
OUT_EN	RESERVED			OUT_IDLE	PWM_SEL		
RW	RW	RW	RW	RW	RW	RW	RW
0	0	0	0	0	0	0	0

- [7] OUT_EN:
Write '1' to set the I/O (configured as GPIO) to operate as PWM Output. All GPIO register setting will be by-passed.
- [6:4] RESERVED
- [3] OUT_IDLE:
Write '1' to set the I/O state to HIGH after PWM sequence has been completed
Write '0' to set the I/O state to LOW after PWM sequence has been completed
- [2:0] PWM_SEL:
Write '1' to set the I/O state to HIGH after PWM sequence has been completed
Write '0' to set the I/O state to LOW after PWM sequence has been completed

11 PWM controller

The PWM controller allows to control the brightness, ramping/fading and blinking of LEDs. The STMPE16M31PX features 8 independent PWM controllers.

The PWM controllers outputs are connected to the GPIO through the PWM array controller. The PAC provides the following list of flexibility to the overall PWM's system:

- Each GPIO may utilize the output of 1 of the 8 PWM controllers.
- Up to 16 GPIO may be controlled by the same PWM at the same time.
- Each of the PWM could be programmed to be triggered by a touch sensing input.

Note: The PWM cannot be programmed to be triggered by a proximity sensing input.

The PWM controller uses a base clock of 512 kHz, clock pulses have a variable duty cycle of 0 to 100% in 16 steps. The PWM's frequency is 32 kHz (to be out of audio range).

11.1 PWM function register map

This section lists and describes the PWM function registers of the STMPE16M31PX device, starting with a register map and then provides detailed descriptions of register types.

Table 12. PWM function registers

Address	Register name	Reset value	R/W	Description
0x30	PWM_MATER_EN	0x00	RW	PWM master enable
0x40	PWM_0_SET	0x00	RW	PWM0 setup
0x41	PWM_0_CTRL	0x00	RW	PWM0 control
0x42	PWM_0_RAMP	0x00	RW	PWM0 ramp rate
0x43	PWM_0_TRIG	0x00	RW	PWM0 trigger
0x44	PWM_1_SET	0x00	RW	PWM1 setup
0x45	PWM_1_CTRL	0x00	RW	PWM1 control
0x46	PWM_1_RAMP	0x00	RW	PWM1 ramp rate
0x47	PWM_1_TRIG	0x00	RW	PWM1 trigger
0x48	PWM_2_SET	0x00	RW	PWM2 setup
0x49	PWM_2_CTRL	0x00	RW	PWM2 control
0x4A	PWM_2_RAMP	0x00	RW	PWM2 ramp rate
0x4B	PWM_2_TRIG	0x00	RW	PWM2 trigger
0x4C	PWM_3_SET	0x00	RW	PWM3 setup
0x4D	PWM_3_CTRL	0x00	RW	PWM3 control
0x4E	PWM_3_RAMP	0x00	RW	PWM3 ramp rate
0x4F	PWM_3_TRIG	0x00	RW	PWM3 trigger

Table 12. PWM function registers (continued)

Address	Register name	Reset value	R/W	Description
0x50	PWM_4_SET	0x00	RW	PWM4 setup
0x51	PWM_4_CTRL	0x00	RW	PWM4 control
0x52	PWM_4_RAMP	0x00	RW	PWM4 ramp rate
0x53	PWM_4_TRIG	0x00	RW	PWM4 trigger
0x54	PWM_5_SET	0x00	RW	PWM5 setup
0x55	PWM_5_CTRL	0x00	RW	PWM5 control
0x56	PWM_5_RAMP	0x00	RW	PWM5 ramp rate
0x57	PWM_5_TRIG	0x00	RW	PWM5 trigger
0x58	PWM_6_SET	0x00	RW	PWM6 setup
0x59	PWM_6_CTRL	0x00	RW	PWM6 control
0x5A	PWM_6_RAMP	0x00	RW	PWM6 ramp rate
0x5B	PWM_6_TRIG	0x00	RW	PWM6 trigger
0x5C	PWM_7_SET	0x00	RW	PWM7 setup
0x5D	PWM_7_CTRL	0x00	RW	PWM7 control
0x5E	PWM_7_RAMP	0x00	RW	PWM7 ramp rate
0x5F	PWM_7_TRIG	0x00	RW	PWM7 trigger

PWM_MASTER_EN

Master enable register

Address: 0x30

Type: RW

Reset: 0x00

Description: ENABLE/DISABLE setting of all PWM channels.

7	6	5	4	3	2	1	0
EN7	EN6	EN5	EN4	EN3	EN2	EN1	EN0
RW	RW	RW	RW	RW	RW	RW	RW
0	0	0	0	0	0	0	0

[7:0] EN-X (X = 7-0)

Write '1' to enable the corresponding PWM channel

Read '0' if the PWM sequence is completed

If PWM is set to be touch sensor-triggered :

Read '1' if the corresponding PWM channel is running

PWM_n_SET

PWM-n setup register

Address: 0x40, 0x44, 0x48, 0x4C, 0x50, 0x54, 0x58, 0x5C

Type: RW

Reset: 0x00

Description: Setting of brightness, time unit and ramp-mode.

7	6	5	4	3	2	1	0
BRIGHTNESS				TIMING			RAMPMODE
RW	RW	RW	RW	RW	RW	RW	RW
0	0	0	0	0	0	0	0

[7:4] BRIGHTNESS:

It defines the duty cycle during the ON period of the PWM channel output in no-ramp mode or the highest duty cycle to be reached in ramp-mode. The PWM duty cycle determines the brightness level of the LED that the PWM output drives.

- '0000' : Duty cycle ratio 1:15 (6.25%, minimum brightness)
- '0001' : Duty cycle ratio 2:14 (12.50%)
- '0010' : Duty cycle ratio 3:13 (18.75%)
- '0011' : Duty cycle ratio 4:12 (25.00%)
- '0100' : Duty cycle ratio 5:11 (31.25%)
- '0101' : Duty cycle ratio 6:10 (37.50%)
- '0110' : Duty cycle ratio 7: 9 (43.75%)
- '0111' : Duty cycle ratio 8: 8 (50.00%)
- '1000' : Duty cycle ratio 9: 7 (56.25%)
- '1001' : Duty cycle ratio 10: 6 (62.50%)
- '1010' : Duty cycle ratio 11: 5 (68.75%)
- '1011' : Duty cycle ratio 12: 4 (75.00%)
- '1100' : Duty cycle ratio 13: 3 (81.25%)
- '1101' : Duty cycle ratio 14: 2 (87.50%)
- '1110' : Duty cycle ratio 15: 1 (93.75%)
- '1111' : Duty cycle ratio 16: 0 (100.00%, maximum brightness).

[3:0] TIMING:

It is the time unit from which the duration of the ON period and OFF period is defined in PWM-N control register.

- '000' = 20 mS
- '001' = 40 mS
- '010' = 80 mS
- '011' = 160 mS
- '100' = 320 mS
- '101' = 640 mS
- '110' = 1280 mS
- '111' = 2560 mS

[0] RAMP MODE:

Write '1' to enable ramp-mode

Write '0' to disable ramp-mode which in this setting the output goes to the set brightness level

PWM_n_CTRL

PWM-n control register

Address: 0x41, 0x45, 0x49, 0x4D, 0x51, 0x55, 0x59, 0x5D

Type: RW

Reset: 0x00

Description: Setting of ON/OFF period, repetition, and ON/OFF order.

7	6	5	4	3	2	1	0
Period 0		Period 1		Repetition			Order
RW	RW	RW	RW	RW	RW	RW	RW
0	0	0	0	0	0	0	0

[7:6] Period 0

Define the ON time based on time unit set in PWM-N setup register

- '00' : 1 time unit
- '01' : 2 time unit
- '10' : 3 time unit
- '11' : 4 time unit

[5:4] Period 1

Define the OFF time based on time unit set in PWM-N setup register

- '00' : 1 time unit
- '01' : 2 time unit
- '10' : 3 time unit
- '11' : 4 time unit

[3:1] Repetition

Set the repetition of programmed sequence (pair of period 0 and period 1)

- '000' : Infinite repetition
- '001' : Execute only one pair
- '010' : Execute 2 pairs
- '011' : Execute 3 pairs
- '100' : Execute 4 pairs
- '101' : Execute 5 pairs
- '110' : Execute 6 pairs
- '111' : Execute 7 pairs

[0] Order

Set the order of period 0 and period 1

- '1' : sequence = period 1 and then period 0
- '0' : sequence = period 0 and then eriod 1

PWM_n_RAMP_RATE

PWM-N ramp rate register

Address: 0x42, 0x46, 0x4A, 0x4E, 0x52, 0x56, 0x5A, 0x5E

Type: RW

Reset: 0x00

Description: Setting of ramp rate

7	6	5	4	3	2	1	0
INV	Reserved	RampDown			RampUp		
RW	RW	RW	RW	RW	RW	RW	RW
0	0	0	0	0	0	0	0

[7] INV
 LED driving/sinking mode
 Write '1' for LED sinking mode (HIGH = LED Off, LOW = LED On)
 Write '0' for LED driving mode (HIGH = LED On, LOW = LED Off)

[6] Reserved

[5:3] RampDown
 Set the PWM ramp down rate
 '000' : 1/4 of time unit per brightness level change
 '001' : 1/8 of time unit per brightness level change
 '010' : 1/16 of time unit per brightness level change
 '011' : 1/32 of time unit per brightness level change
 '100' : 1/64 of time unit per brightness level change
 '101' : 1/128 of time unit per brightness level change
 '110' : reserved
 '111' : reserved

[2:0] RampUp
 Set the PWM ramp up rate
 '000' : 1/4 of time unit per brightness level change
 '001' : 1/8 of time unit per brightness level change
 '010' : 1/16 of time unit per brightness level change
 '011' : 1/32 of time unit per brightness level change
 '100' : 1/64 of time unit per brightness level change
 '101' : 1/128 of time unit per brightness level change
 '110' : reserved
 '111' : reserved

PWM_n_TRIG

PWM-N trigger register

Address: 0x43, 0x47, 0x4B, 0x4F, 0x53, 0x57, 0x5B, 0x5F

Type: RW

Reset: 0x00

Description: Setting of touch sensor-triggered PWM.

7	6	5	4	3	2	1	0
RESERVED	EN		TS_CH				
RW	RW	RW	RW	RW	RW	RW	RW
0	0	0	0	0	0	0	0

[7:6] RESERVED

[6:5] EN:

Write '1' to enable touch sensor-triggered PWM function

Write '0' to disable touch sensor-triggered PWM function

[4:0] TS_CH

Define the touch sensor channel which is set as trigger of the corresponding PWM channel.

Note: The PWM cannot be programmed to be triggered by a proximity sensing input.

12 Basic PWM programming

The PWM controllers are capable of generating the following brightness patterns:

Figure 9. Pulses with programmable brightness, ON/OFF period and repetition

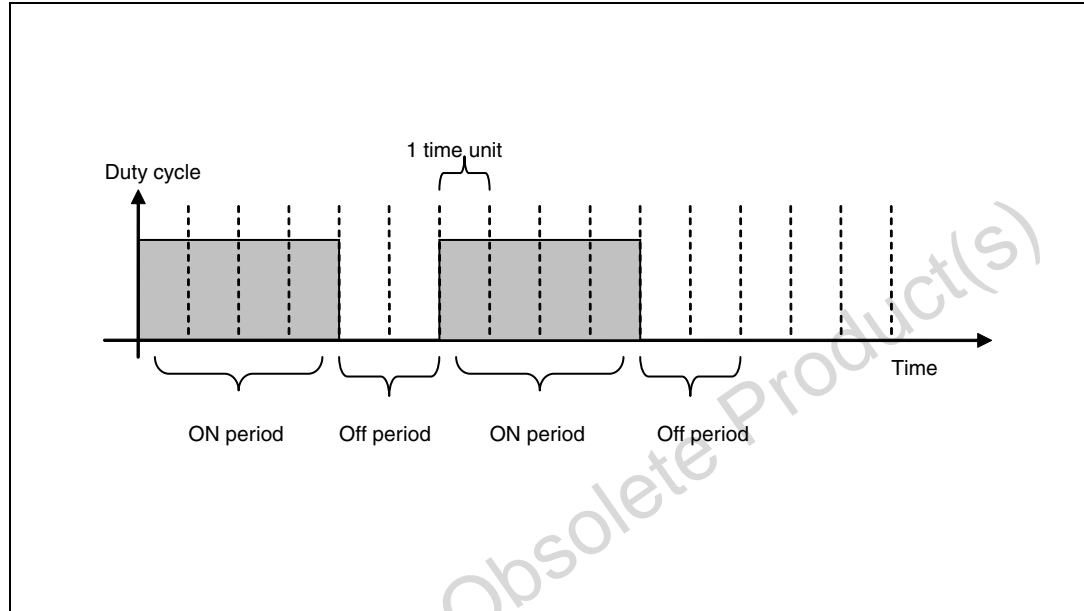

The registers need to be programmed for this sequence:

- On period = $\text{Period } 0[1:0] * \text{Time Unit } [3:0]$
- Off period = $\text{Period } 1[1:0] * \text{Time Unit } [3:0]$
- Duty cycle during on period = $\text{Brightness } [7:4]$
- Number of cycles = $\text{Repetition } [3:0]$
- Ramp-mode is disabled

Figure 10. Ramps with programmable brightness, ON/OFF period and repetition

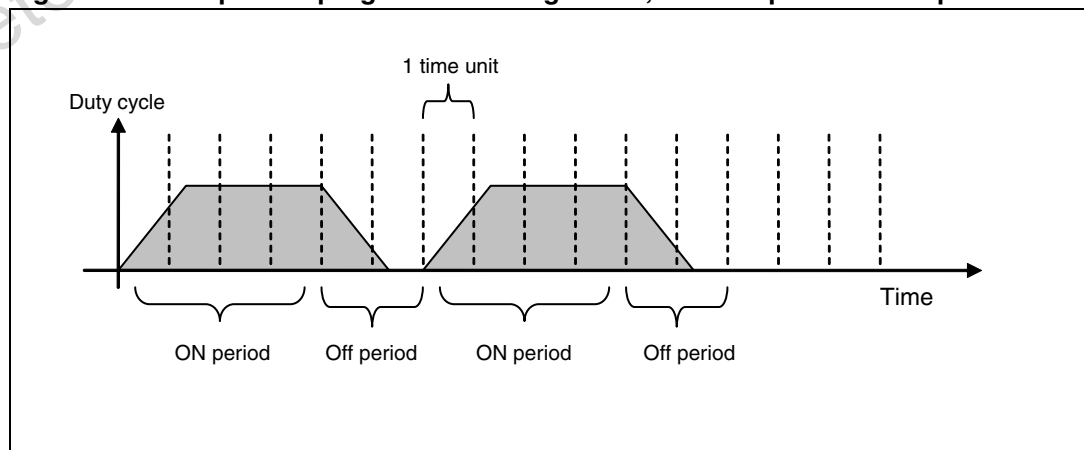

The registers need to be programmed for this sequence :

- On Period = Period 0[1:0] * Time Unit [3:0]
- Off Period = Period 1[1:0] * Time Unit [3:0]
- Duty cycle during On Period = Brightness [7:4]
- Number of cycles = Repetition [3:0]
- Ramp-Mode is enabled
- Ramp Up/Down Rate is programmable

Figure 11. Fixed brightness output

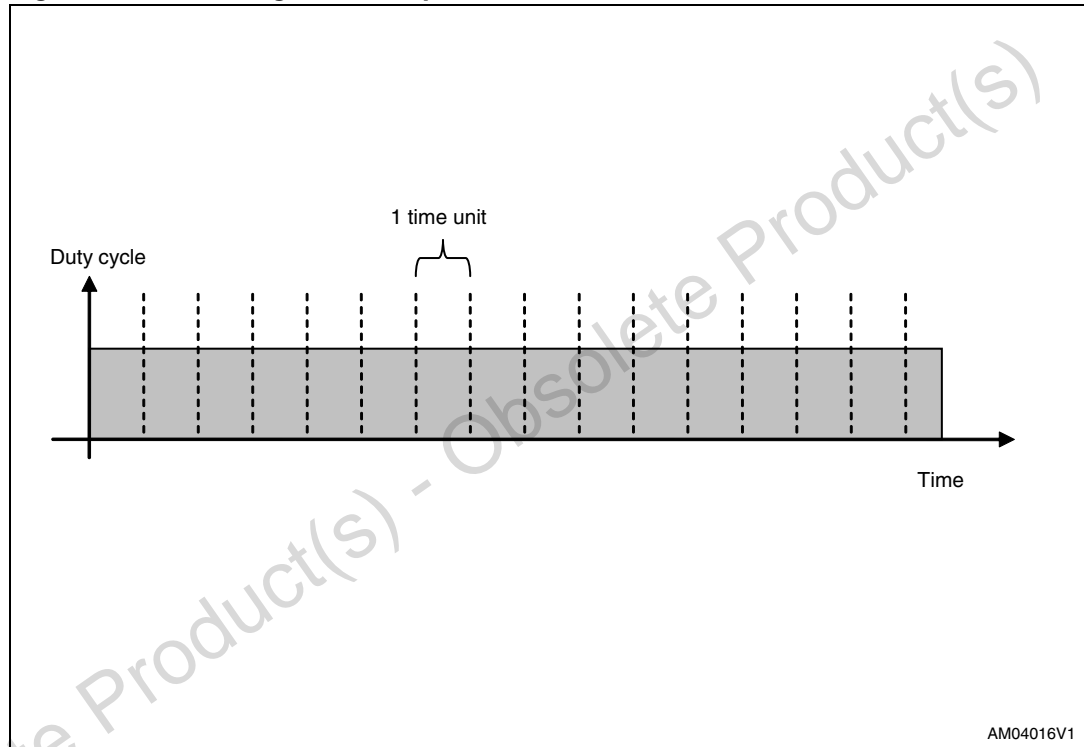

- On Period = Period 0[1:0] * Time Unit [3:0]
- Off Period = Don't Care
- Duty Cycle during On Period = Brightness [7:4]
- Number of cycles = Repetition [3:0] = 0 (infinite repetition)

12.1 Interrupt on basic PWM controller

A basic PWM controller could be programmed to generate interrupt on completion of blinking sequence. User needs to consider:

- a) Each basic PWM controller has its own bit in interrupt enable/status registers.

If enabled, the completion in any of the PWM controllers triggers an interrupt. No interrupt will be generated if infinite repetition is set.

Obsolete Product(s) - Obsolete Product(s)

13 Touch sensor controller

The STMPE16M31PX device uses the STMicroelectronics' patent pending capacitive front end. The capacitive sensor is configure by the following registers:

Table 13. Touch sensor controller registers

Address	Register Name	Reset Value	R/W	Description
0x70	CH_SEN_CTRL	0x00	RW	Capacitive sensor control
0x72 - 0x73	CH_SEL	0x0000	RW	Selects active capacitive channels
0x76	CAL_INT	0x00	RW	10mS – 64S calibration interval
0x77	CAL_MOD	0x00	RW	Selects calibration model
0x78	MAF_SET	0x00	RW	Median averaging filter (MAF) setting
0x7C	DATA_TYPE	0x00	RW	Selects type of data available in channel data ports. 0x01: TVR 0x02: EVR 0x03: Channel delay 0x04: Impedance (13-bit) 0x05: Calibrated impedance (13-bit) 0x06: Locked impedance (13-bit)
0xC0-0xDF	CH_DATA-n	0x0000	R/W	Channel data based on channel data type

Figure 12. Touch sensing module flowchart

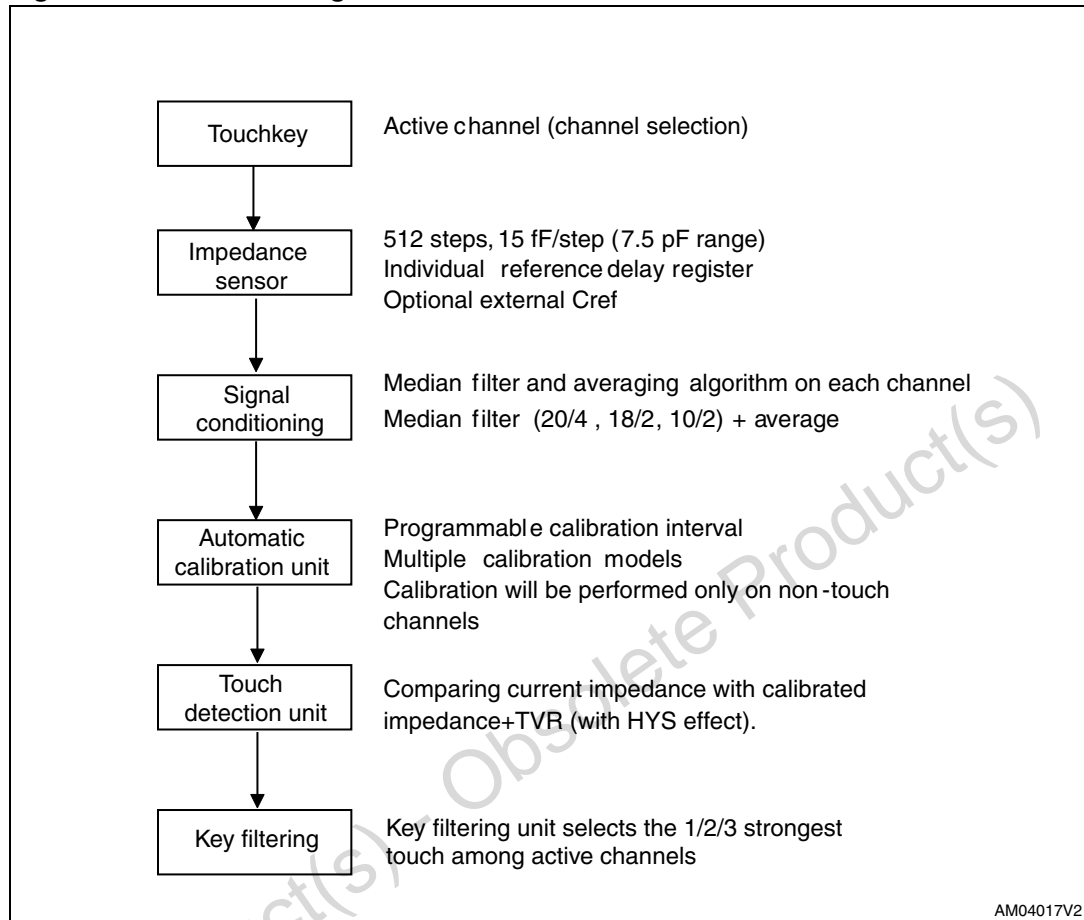

13.1 Sampling rate calculation

The capacitive sensor operates with a 2 MHz base clock, a single capacitive sensor scans up to 16 active channels.

The SCLK_DIV divides the sensor clock by 32-1024, giving 2 kHz-67.5 kHz sensor clock.

For capacitive sensing, a PRBS sequence is utilized to remove the effect of surrounding noise. This PRBS has an average value of 4.5.

The effective total sampling rate is thus 2 kHz-67.5 kHz divided by 4.5, giving 440 Hz – 14 kHz.

If all 16 channels of capacitive sensors are active, the channel conversion rate is thus $440 \text{ Hz}/16 = 27.5 \text{ Hz (Min)}$, $14 \text{ kHz}/16 = 875 \text{ Hz (Max)}$

Using the maximum MAF setting (18 remove 2), the maximum filtered channel output rate is $875 \text{ Hz}/18 = 48.6 \text{ Hz}$.

13.2 Sensor resolution

The capacitive sensor hardware in the STMPE16M31PX devices has a sensitivity of 15 fF and a range of 512 steps giving it a dynamic range of 7.5 pF.

The impedance reading is the output of an internal MAF (median averaging filter). As up to 16 samples are taken for each reading, the impedance reading is the sum of 16 of 9-bit samples.

To allow maximum consistency, the 3 impedance readings are **always** 13-bit, whichever MAF setting is used.

The touch variance (TVR) and enviromental variance (EVR) registers are specified in a 9-bit format. For comparison with the impedances, the TVR and EVR would be internally shifted 4 bits up.

13.3 Auto-tuning

The capacitive sensor hardware in the STMPE16M31PX devices has a sensitivity of 15 fF and a range of 512 steps giving it a dynamic range of 7.5 pF. This means that at any time, the device is able to sense a change in capacitance up to 7.5 pF. When the channel capacitance moves out of the 7.5 pF window, the auto tuning feature kicks in to ensure proper sensing operation.

Figure 13. Auto-tuning operation

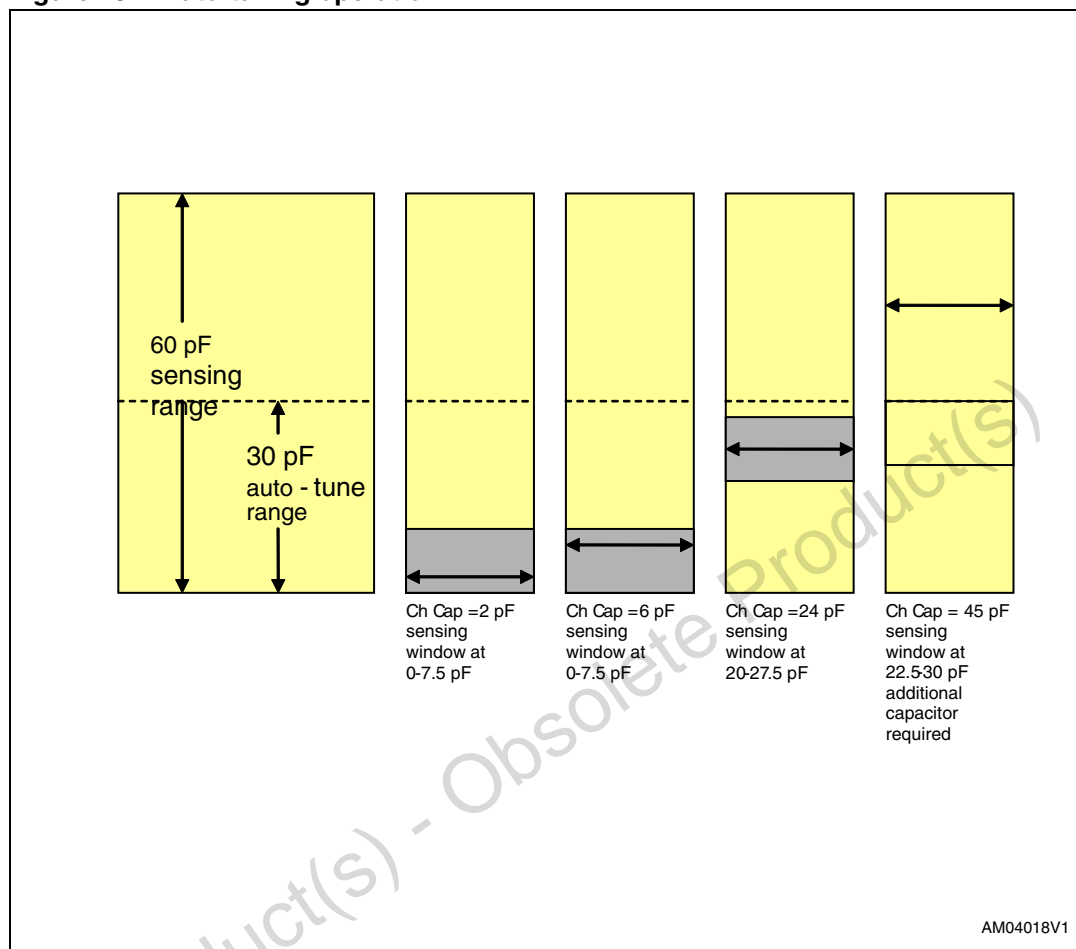

13.4 Locked impedance

Locked impedance is data available in channel data the moment 0x06 is written into “channel data type register”. Writing a different value into the “channel data type register” allows the locked impedance to be refreshed.

In actual application, software writes 0x06, reads locked impedance, writes 0x00, writes 0x06, and reads the next set of data.

For data type 0x04-0x05, data are constantly being refreshed, even as it is being accessed. If accessed slowly, the full set of data may have been sampled at significantly different time.

13.5 Calibration

Calibration event is performed in every period which is programmable from the calibration interval register (0x76). In each calibration event, 8 impedance samples are collected and averaged. The time period between samples is programmable from CAL_MOD (model register (0x77)).

Figure 14. Calibration

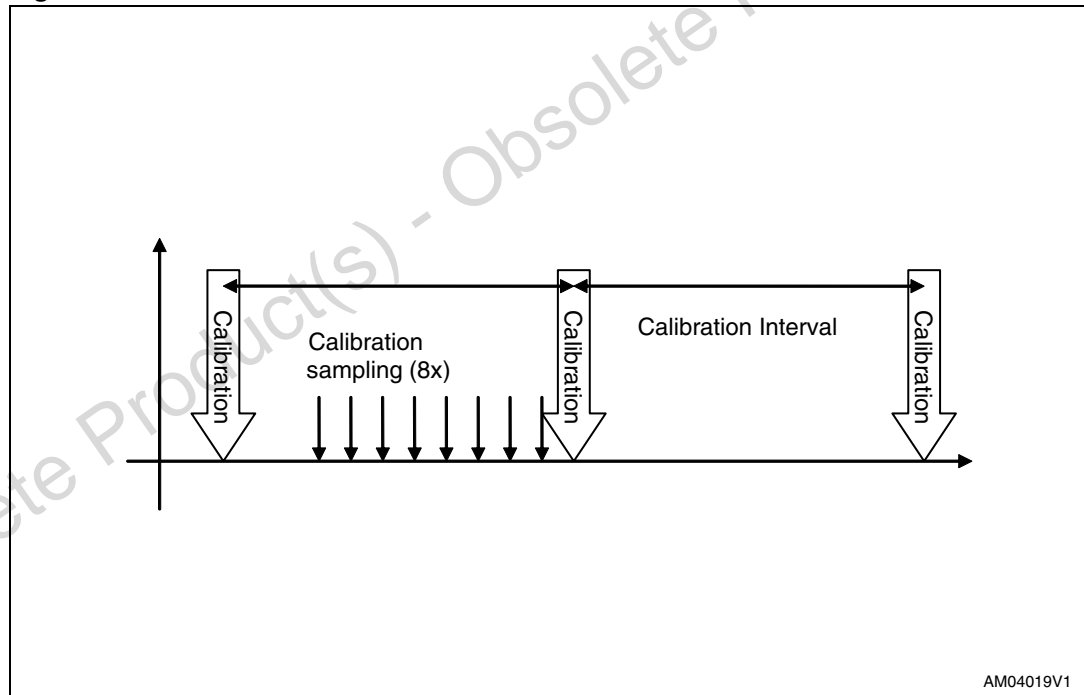

AM04019V1

CAP_SEN_CTRL

Capacitive sensor control register

Address: 0x70

Type: RW

Reset: 0x00

Description: This register controls the capacitive sensor’s operation.

7	6	5	4	3	2	1	0
CS_EN	HYS						ForcedAT
RW	RW	RW	RW	RW	RW	RW	RW
0	0	0	0	0	0	0	0

[7] CS_EN

Write ‘1’ to enable the capacitive sensor module
 Write ‘0’ to disable the capacitive sensor module

This bit should be set after all other touch sensor setting have been written. The changes in other setting when this bit is ‘1’ is not allowed.

If ratio-engine or key-filter unit is used, this bit should only be set, after ratio-engine and key-filter unit has been configured.

[6:1] HYS

TVR Hysteresis

When there is no touch, the value of TVR is used as threshold to determine touch condition.

If touch is detected, the touch detection threshold is changed to TVR-(HYS*4), hence the effective value of hysteresis is 0-256.

[0] ForcedAT

Write ‘1’ to initiate unconditional forced auto-tuning to center the static impedance value in the dynamic range. Prior sending this command, the calibration model must be set to mode ‘10’ with auto-tuning enabled.

Read ‘1’ if the auto-tuning process in progress

Read ‘0’ if the auto-tuning process has been completed.

It is required that upon start up the system, this command is called once.

When the auto-tuning is executed in the presence of finger on the sensor, the ‘touch’ status will become ‘no-touch’ after completion of the process. Once finger is removed, the auto-calibration will take care of this situation allowing the detection of next ‘touch’ event.

CH_SEL

Channel selection register

Address: 0x72-0x73

Type: RW

Reset: 0x000000

Description: This register configures the active capacitive sensing channels.

Bit 7-0 (0x72)

7	6	5	4	3	2	1	0
S7	S6	S5	S4	S3	S2	S1	S0
RW	RW	RW	RW	RW	RW	RW	RW
0	0	0	0	0	0	0	0

Bit 15-8 (0x73)

7	6	5	4	3	2	1	0
S15	S14	S13	S12	S11	S10	S9	S8
RW	RW	RW	RW	RW	RW	RW	RW
0	0	0	0	0	0	0	0

[7:0] S-X

Write '1' to enable the corresponding capacitive sensor channel

Write '0' to disable the corresponding capacitive sensor channel

CAL_INT**Calibration interval configuration register****Address:** 0x76**Type:** RW**Reset:** 0x00**Description:** This register configures the interval between successive calibrations.

7	6	5	4	3	2	1	0
MULTIPLIER		INTERVAL					
RW	RW	RW	RW	RW	RW	RW	RW
0	0	0	0	0	0	0	0

[7:6] MULTIPLIER

Set the multiplier value for calibration interval set in Interval[5:0]

'00' for 8

'01' for 32

'10' for 128

'11' for 512

[5:0] INTERVAL

Set the calibration interval

Calibration interval :

= Interval[5:0]*10 mS * multiplier.

CAL_MOD

Calibration mode register

Address: 0x77

Type: RW

Reset: 0x00

Description: This register configures the way calibration samples are collected, and the model of calibration algorithm.

7	6	5	4	3	2	1	0
CSInterval					Model		Cal_EN
RW	RW	RW	RW	RW	RW	RW	RW
0	0	0	0	0	0	0	0

[7:3] CSInterval

Set the interval between samples in one calibration unit
 Interval = CSInterval[4:0]*10mS

[2:1] IModel

Set the calibration model
 '00' for normal auto-calibration
 '10' for auto-calibration with auto-tuning. In this mode channel reference delay is not accessible from I2C. The system will perform auto-tuning if the impedance is moving out of dynamic range.
 '01' is reserved
 '11' is reserved

[0] Cal_EN

'1' to enable the auto-calibration
 '0' to disable the auto-calibration

Obsolete Product(s) - Obsolete Product(s)

MAF_SET

Median averaging filter register

Address: 0x78

Type: RW

Reset: 0x00

Description: This register chooses the median averaging filter mode.

7	6	5	4	3	2	1	0
Reserved					MAF_Mode		MAF_EN
RW	RW	RW	RW	RW	RW	RW	RW
0	0	0	0	0	0	0	0

- [2:1] MAF_Mode
 - '00' to collect 10 samples, remove 2 samples
 - '01' to collect 18 samples, remove 2 samples
 - '10' to collect 20 samples, remove 4 samples
- [0] MAF_EN
 - '1' Enable the MAF
 - '0' Disable the MAF

DATA_TYPE

Data type definition register

Address: 0x7C

Type: RW

Reset: 0x00

Description: This register define the type of data to be accessed at capacitive channel data register.

7	6	5	4	3	2	1	0
MODE							
RW	RW	RW	RW	RW	RW	RW	RW
0	0	0	0	0	0	0	0

- [7:0] MODE
 - 0x01: TVR (9-bit)
 - 0x02: EVR (9-bit)
 - 0x03: Channel delay (6-bit)
 - 0x04: Impedance (13-bit)
 - 0x05: Calibrated impedance (13-bit)
 - 0x06: Locked impedance (13-bit)

CH_DATA-n

CHDATA-n registers (0-15)

Address: 0xC0-0xDF

Type: RW

Reset: 0x00

Description: Capacitive sensor channel data. The type of data represented by this register depends on the channel data type register (0x7C).

LSB, address : 0xC0 + (2*N), N = channel number

7 6 5 4 3 2 1 0

Channel N data [7:0]

RW	RW	RW	RW	RW	RW	RW	RW
0	0	0	0	0	0	0	0

MSB, address : 0xC0 + (2*N+1), N = channel number

7 6 5 4 3 2 1 0

Channel N data [15:8]

RW	RW	RW	RW	RW	RW	RW	RW
0	0	0	0	0	0	0	0

[16:0] Channel data

Display data selected by channel data type register (0x7C)

13.6 Definition of data accessible through channel data register

Table 14. Types of data accessible through the channel data register

Data name	Definition
TVR	TVR (touch variance register) is a threshold defined by system, of which, if the sense impedance changed by a magnitude more than the associated TVR, this channel is considered touched. The result of this comparison is directly accessible in the TOUCH_DET register.
EVR	EVR (environmental variance register) is a threshold defined by system, of which, if the sensed impedance changed by a magnitude less than the associated EVR, this is considered an environmental change and the device will calibrate the internal reference (calibrated impedance) accordingly.
Channel delay	Channel delay is used to tune the individual channel into effective measurement range. This field is 6-bit (0-63). Each bit in this field represents approximately 0.5 pF capacitance.
Impedance	<p>This field is a real time reflection of impedance measured at the corresponding channel. As capacitance is inversely proportional to impedance, this field reduces in value when capacitance on the channel increases.</p> <p>This field is of 13-bit length. The least significant 4 bits are results of internal processing and should not be used. The actual impedance data could be obtained by shifting the [Impedance] 4 bits to the right.</p>
Calibrated Impedance	<p>Read-only</p> <p>This field contains an internal reference used by the device to decide whether a touch has occurred. This value is adjusted regularly (calibration) by the device automatically.</p>
Locked impedance	<p>Data in this field is similar to data in impedance field, except that once this data type is chosen, the device maintains a complete set of impedance data in this field and stop refreshing it.</p> <p>This is useful for the application where it is required that all impedance data are sampled within a very short time.</p>

14 Touchkey and proximity sensing controller

The touchkey controller processes raw capacitance measurement data into “touch/no-touch” boolean data for easy usage. The key filter unit provides additional flexibility by allowing the system to define a maximum number of keys that could be detected and considered active, based on the amount of impedance change detected.

The proximity sensor using a technique called ‘dithering’ to increase the sensitivity of one selected channel. Dithering factor (configurable from 4 - 32x) determines the sensitivity of proximity sensor.

Table 15. Touchkey controller registers

Address	Register name	Reset value	R/W	Description
0x90	KFU_PROX_CTRL	0x00	R/W	Key filter and proximity sensor control
0x92 - 0x93	KEY_FILT_GROUP1	0x0000	R/W	Define channels included in key filter group 1
0x96	PROX_CFG	0x00	R/W	Proximity configuration register
0x97	PTVR	0x00	R/W	Proximity variance register (PTVR)
0x98	PEVR	0x00	R/W	Proximity enviromental variance register
0xB0	PROX_DATA_0	0x00	R	Proximity data port 0
0xB1	PROX_DATA_1	0x00	R	Proximity data port 1
0x9A - 0x9B	KEY_FILT_DATA	0x0000	R	Filtered touchkey data
0xB4-0xB5	TOUCH_DET	0x0000	R	Touch detection register (real time)

Figure 15. Data flow in touchkey controller

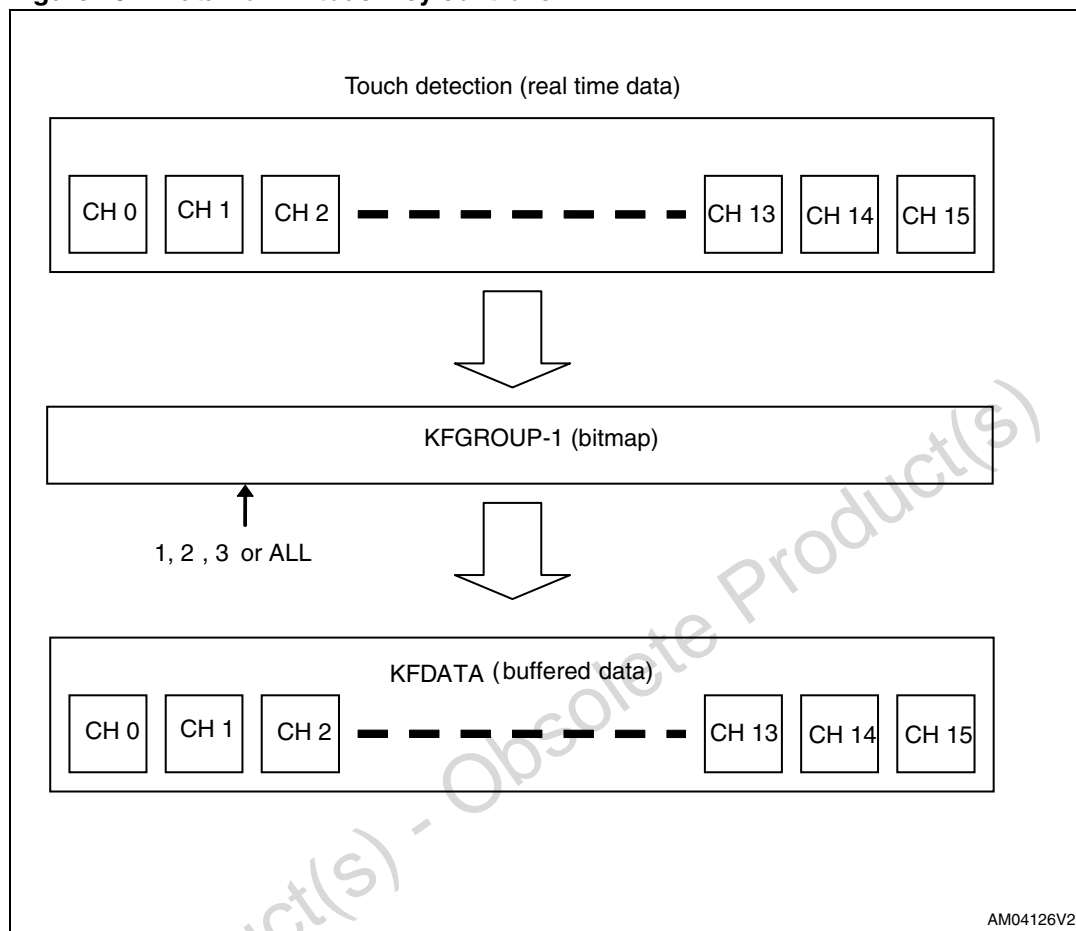

KEY_PROX_CTRL

Key filter unit configuration register

Address: 0x90

Type: RW

Reset: 0x00

Description: Setting of key filter unit.

7	6	5	4	3	2	1	0
PROX_CHL_SELECT				RESERVED	PROX_EN	Mode_KFU1	
RW	RW	RW	RW	RW	RW	RW	RW
0	0	0	0	0	0	0	0

[7:4] PROX_CHL_SELECT:

Chooses one of the first 16 sensing channel as proximity sebsor input

[3] RESERVED

[2] PROX_EN:

Write '1' to enable proximity sensing operation. Write '0' to disable proximity sensing operation.

[1:0] Mode_KFU

'00' for no filter

'01' for 1 highest impedance change

'10' for 2 highest impedance change

'11' for 3 highest impedance change

KEY_FILT_GROUP-1**KFGROUP-1****Address:** 0x92-0x93 (KeyFilterMask1)**Type:** R/W**Reset:** 0x000000**Description:** Configure the channels included in a group of key filter unit.**Bit 7-0 (0x92)**

7	6	5	4	3	2	1	0
S7	S6	S5	S4	S3	S2	S1	S0
RW	RW	RW	RW	RW	RW	RW	RW
0	0	0	0	0	0	0	0

Bit 15-8 (0x93)

7	6	5	4	3	2	1	0
S15	S14	S13	S12	S11	S10	S9	S8
RW	RW	RW	RW	RW	RW	RW	RW
0	0	0	0	0	0	0	0

[15:0] S-X

Write '1' to include the corresponding channel in a group of Key Filter Unit

KEY_FILT_DATA

Key filter data register

Address: 0x9A-0x9B

Type: RW

Reset: 0x000000

Description: Represent the status of (touch/no-touch), after being filtered by key filter unit. This register is always active and key status can be accessed from this register regardless of key filter unit activity.

Bit 7-0 (0x9A)

7	6	5	4	3	2	1	0
S7	S6	S5	S4	S3	S2	S1	S0
RW	RW	RW	RW	RW	RW	RW	RW
0	0	0	0	0	0	0	0

Bit 15-8 (0x9B)

7	6	5	4	3	2	1	0
S15	S14	S13	S12	S11	S10	S9	S8
RW	RW	RW	RW	RW	RW	RW	RW
0	0	0	0	0	0	0	0

[15:0] S-X

Read '1' if the corresponding sensor channel status is 'touched'.

TOUCH_DET**Touchkey detection register****Address:** 0xB4-B5**Type:** RW**Reset:** 0x0000**Description:** Represents the real time status of the touchkey input. This is a direct result of comparison of sensed impedance with calibrated impedance (taking in account of hysteresis). This data is not buffered.**Bit 7-0 (0xB4)**

7	6	5	4	3	2	1	0
S7	S6	S5	S4	S3	S2	S1	S0
RW	RW	RW	RW	RW	RW	RW	RW
0	0	0	0	0	0	0	0

Bit 15-8 (0xB5)

7	6	5	4	3	2	1	0
S15	S14	S13	S12	S11	S10	S9	S8
RW	RW	RW	RW	RW	RW	RW	RW
0	0	0	0	0	0	0	0

[15:0] S-X

Read '1' if the corresponding sensor channel status is 'touched'

PROX_CFG

Proximity configuration register

7	6	5	4	3	2	1	0
DITHERING		RESERVED	PROXIMITY CALIBRATION INTERVAL			ACCESS MODE	
R/W	R/W	R/W	R/W	R/W	R/W	R/W	R/W
0	0	0	0	0	0	0	0

Address: 0x96

Type: RW

Reset: 0x00

Description: Proximity configuration register.

[7:6] DITHERING FACTOR

- 00 - 4x
- 01 - 8x
- 10 - 16x
- 11 - 32x

The higher the dithering factor, the more sensitive the proximity sensing is. However, the speed will be slower.

[5] Reserved

[4:2] Proximity calibration interval:

- 000-1
- 001-2
- 010-4
- 011-8
- 100-16

Others: reserved

Controls the number of dithered impedance sampling between successive calibrations. Shorter calibration interval allows it to adapt quickly to changes in environmental factors, but reduces the sensitivity to slowly approaching hand.

[1:0] Access mode:

- 00-dithered impedance
- 01- calibrated dithered impedance
- others: reserved

PTVR**Proximity variance register****Address:** 0x97**Type:** RW**Reset:** 0x00**Description:** Proximity variance register. Typical value is 0x08 - 0x20

Obsolete Product(s) - Obsolete Product(s)

PEVR

Proximity enviromental variance register

Address: 0x98

Type: RW

Reset: 0x00

Description: Proximity enviromental variance register.

[7] Forced proximity calibration.

Writing '1' to this bit forces the proximity sensing module to use the current dithered impedance as calibrated dithered impedance. After writing '1' to this bit, I2C should monitor the calibration status bit (Prox Data Port 1, bit 6). On reading '1' in calibration status bit, I2C must write '0' in forced proximity calibration bit to complete the calibration action.

[6] EVR used for proximity detection. typically value of 0x02-0x05 is used.

PROX DATA PORT

Proximity DATA PORT

15	14	13	12	11	10	9	8	7	6	5	4	3	2	1	0
PROX_STA	CAL_STA	RESERVED	Dithered Impedance/calibrated dithered impedance												
R	R	R	R												
0	0	0	0	0	0	0	0	0	0	0	0	0	0	0	0

Address: 0xB0 (LSB), 0xB1 (MSB)

Type: R

Reset: 0x00

Description: Proximity data port.

[7:6] Proximity status: real-time status of proximity sensor

[14] Calibration status:

Reads '1' if calibration is completed.

Reads '0' if I2C executes a forced calibration

[13] Reserved

[12:0] 13 bit dithered impedance/calibrated dithered impedance.

The data read in this location is controlled by the access mode setting in PROX_TRIG register.

15 Maximum rating

Stressing the device above the rating listed in the “Absolute maximum ratings” table may cause permanent damage to the device. These are stress ratings only and operation of the device at these or any other conditions above those indicated in the operating sections of this specification is not implied. Exposure to absolute maximum rating conditions for extended periods may affect device reliability.

Table 16. Absolute maximum ratings

Symbol	Parameter	Value	Unit
V _{CC}	Supply voltage	2.5	V
V _{IO}	GPIO aND vreg SUPPLY VOLTAGE	6	V
VESD (HBM)	ESD protection on each GPIO/TOUCH pin	8	KV

15.1 Recommended operating conditions

Table 17. Recommended operating conditions

Symbol	Parameter	Value		Unit
		Min	Max	
V _{CC}	Supply voltage	1.65	1.95	V
V _{IO}	GPIO supply voltage	2.7	5.5	V
GPIO	GPIO input voltage	GND-0.5	VIO+0.5	KV

16 DC electrical characteristics

-40 to 85 °C unless stated otherwise.

Table 18. DC electrical characteristics

Symbol	Parameter	Test conditions	Value			Unit
			Min	Typ	Max	
V _{CC}	Core supply voltage		1.65	-	1.95	V
V _{IO}	IO supply voltage		2.7	-	5.5	V
I _{active}	ACTIVE current	2 MHz/32 sensor clock, PROXIMITY engine active	-	600	900	µA
I _{active}	ACTIVE current	2 MHz/32 sensor clock, with/without touch, key only	-	400	600	µA
I _{sleep}	SLEEP current	2 MHz/32 sensor clock, without touch	-	50	75	µA
I _{hibernate}	HIBERNATE current	No sensing capability. Hotkey available	-	5	8	µA
V _{IL}	Input voltage low state (RESET/A0/A1/I2C)	V _{CC} = 1.8 V	-0.3V	-	0.35V _{CC}	V
V _{IH}	Input voltage high state (RESET/A0/A1/I2C)	V _{CC} = 1.8 V	0.75V _c	-	V _{CC} +0.3 V	V
V _{IL}	Input voltage low state (GPIO)	V _{IO} = 2.7 - 5.5 V	-0.3V	-	0.35V _{IO}	V
V _{IH}	Input voltage high state (GPIO)	V _{IO} = 2.7 - 5.5 V	0.65V _{IO}	-	V _{IO} +0.3 V	V
V _{OL}	Output voltage low state (GPIO)	V _{IO} = 2.7 - 5.5 V, I _{OL} = 12 mA	-0.3V	-	0.25V _{IO}	V
V _{OH}	Output voltage high state (GPIO)	V _{IO} = 2.7- 5.5 V, I _{OL} = 12 mA	0.75V _{IO}	-	V _{IO} +0.3 V	V
I _{leakage}	Input leakage on all GPIO/touch pins	V _{IO} = 5.5 V, V _{CC} powered by V _{IO} , I/O set as input, 5.5 V applied to I/O	-	-	100	nA

16.1 Capacitive sensor specification

-40 to 85 °C unless stated otherwise.

Symbol	Parameter	Test conditions	Value			Unit
			Min	Typ	Max	
Cs	Capacitive sensor sensitivity	$V_{IO} = 2.7 - 5.5$ V, internal V_{REG}	12	16	25	fF
Csvr	Variance of Cs across channels	$V_{IO} = 2.7 - 5.5$ V, internal V_{REG}	-	10	-	%

Obsolete Product(s) - Obsolete Product(s)

17 Package mechanical data

In order to meet environmental requirements, ST offers these devices in different grades of ECOPACK® packages, depending on their level of environmental compliance. ECOPACK® specifications, grade definitions and product status are available at: www.st.com. ECOPACK® is an ST trademark.

Figure 16. Package outline for QFN32 (4 x 4 mm) - pitch 0.4 mm

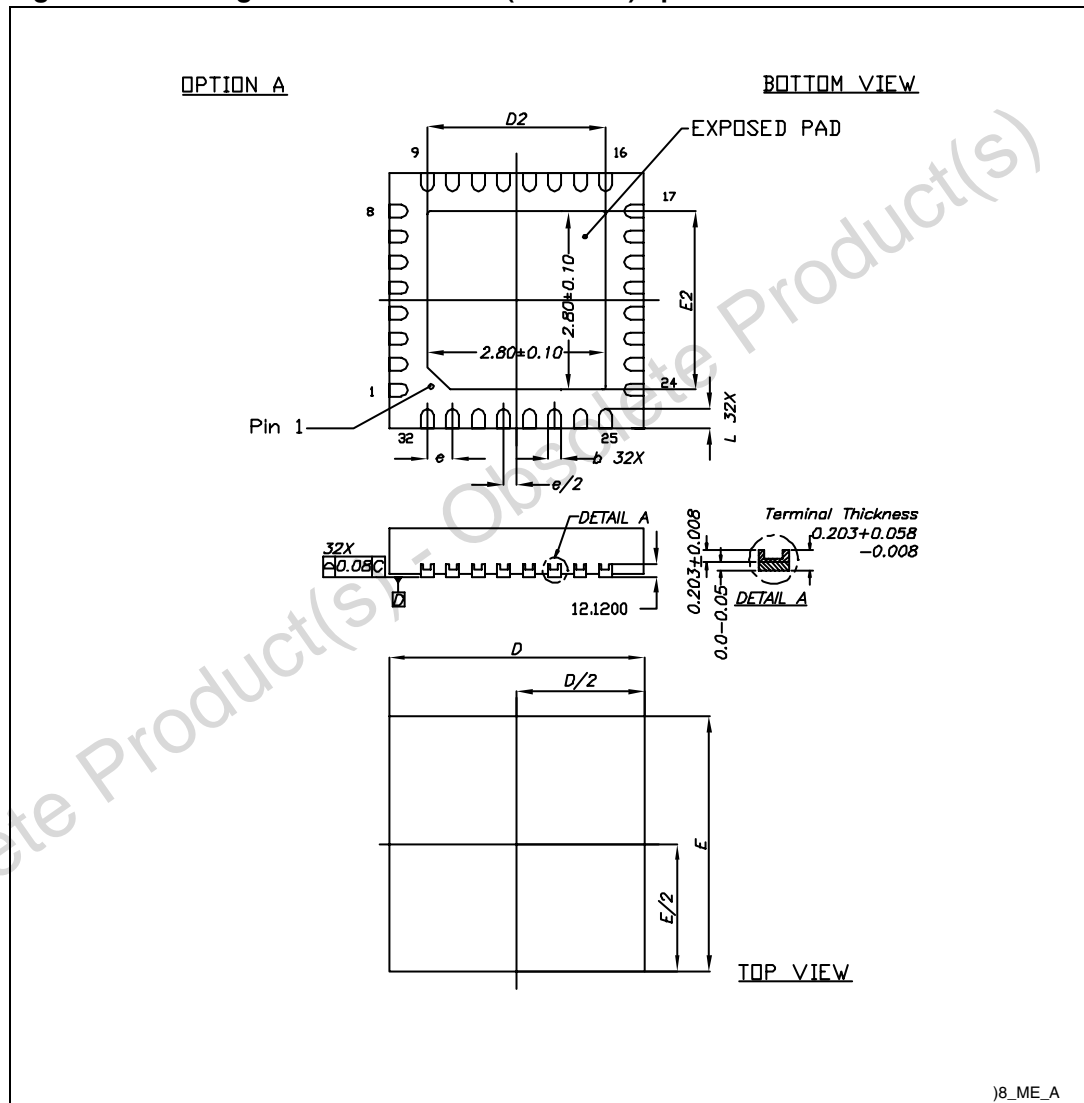
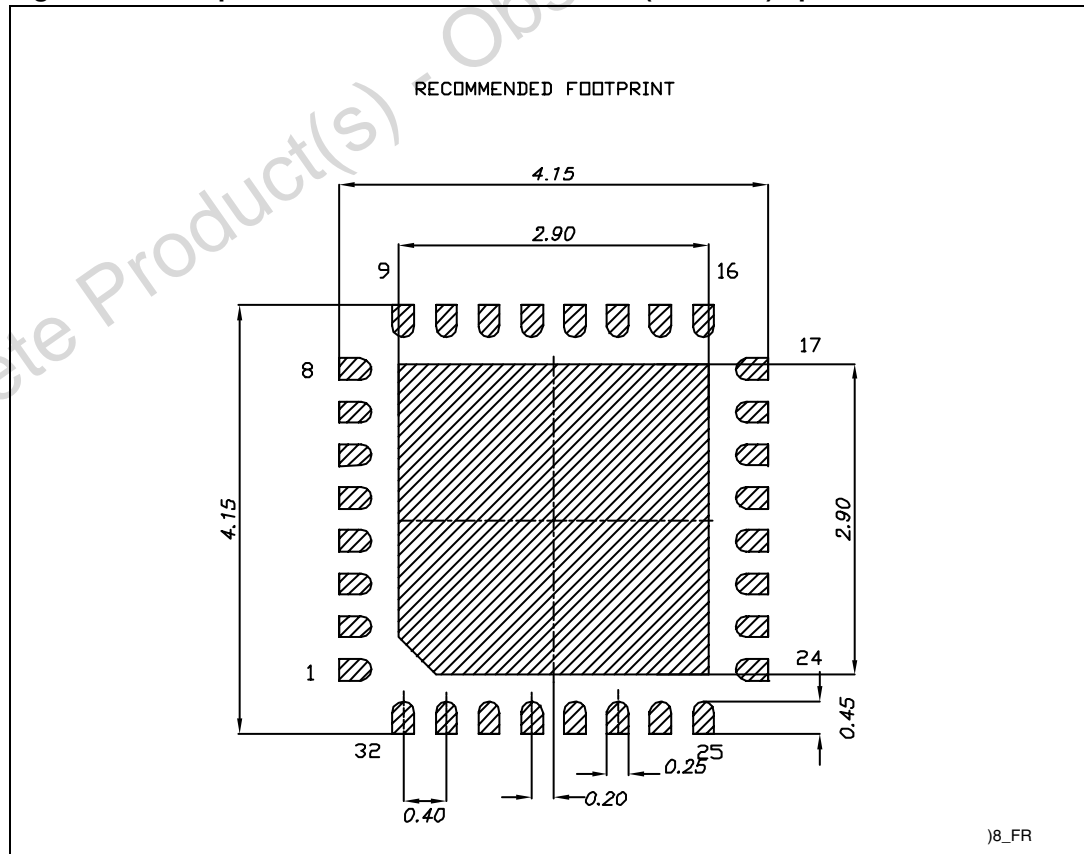

Table 19. Package mechanical data for QFN32 (4 x 4 mm) - pitch 0.4 mm

Symbol	Millimeters		
	Min	Typ	Max
A	0.70	-	0.90
A1	0.03	0.05	0.08
A3	-	0.20	-
b	0.19	0.21	0.28
D	3.85	4.00	4.15
D2	2.70	2.80	2.90
E	3.85	4.00	4.15
E2	2.70	2.80	2.90
e	-	0.40	-
e/2	-	0.20	-
L	0.10	0.20	0.30

Figure 17. Footprint recommendation for QFN32 (4 x 4 mm) - pitch 0.4 mm



18 Revision history

Table 21. Document revision history

Date	Revision	Changes
08-Dec-2009	1	Initial release.
11-Jan-2011	2	Document status promoted from preliminary data to datasheet. Updated QFN32 package mechanical data. Removed STMPE24M31PX part number.

Obsolete Product(s) - Obsolete Product(s)

Please Read Carefully:

Information in this document is provided solely in connection with ST products. STMicroelectronics NV and its subsidiaries ("ST") reserve the right to make changes, corrections, modifications or improvements, to this document, and the products and services described herein at any time, without notice.

All ST products are sold pursuant to ST's terms and conditions of sale.

Purchasers are solely responsible for the choice, selection and use of the ST products and services described herein, and ST assumes no liability whatsoever relating to the choice, selection or use of the ST products and services described herein.

No license, express or implied, by estoppel or otherwise, to any intellectual property rights is granted under this document. If any part of this document refers to any third party products or services it shall not be deemed a license grant by ST for the use of such third party products or services, or any intellectual property contained therein or considered as a warranty covering the use in any manner whatsoever of such third party products or services or any intellectual property contained therein.

UNLESS OTHERWISE SET FORTH IN ST'S TERMS AND CONDITIONS OF SALE ST DISCLAIMS ANY EXPRESS OR IMPLIED WARRANTY WITH RESPECT TO THE USE AND/OR SALE OF ST PRODUCTS INCLUDING WITHOUT LIMITATION IMPLIED WARRANTIES OF MERCHANTABILITY, FITNESS FOR A PARTICULAR PURPOSE (AND THEIR EQUIVALENTS UNDER THE LAWS OF ANY JURISDICTION), OR INFRINGEMENT OF ANY PATENT, COPYRIGHT OR OTHER INTELLECTUAL PROPERTY RIGHT.

UNLESS EXPRESSLY APPROVED IN WRITING BY AN AUTHORIZED ST REPRESENTATIVE, ST PRODUCTS ARE NOT RECOMMENDED, AUTHORIZED OR WARRANTED FOR USE IN MILITARY, AIR CRAFT, SPACE, LIFE SAVING, OR LIFE SUSTAINING APPLICATIONS, NOR IN PRODUCTS OR SYSTEMS WHERE FAILURE OR MALFUNCTION MAY RESULT IN PERSONAL INJURY, DEATH, OR SEVERE PROPERTY OR ENVIRONMENTAL DAMAGE. ST PRODUCTS WHICH ARE NOT SPECIFIED AS "AUTOMOTIVE GRADE" MAY ONLY BE USED IN AUTOMOTIVE APPLICATIONS AT USER'S OWN RISK.

Resale of ST products with provisions different from the statements and/or technical features set forth in this document shall immediately void any warranty granted by ST for the ST product or service described herein and shall not create or extend in any manner whatsoever, any liability of ST.

ST and the ST logo are trademarks or registered trademarks of ST in various countries.

Information in this document supersedes and replaces all information previously supplied.

The ST logo is a registered trademark of STMicroelectronics. All other names are the property of their respective owners.

© 2011 STMicroelectronics - All rights reserved

STMicroelectronics group of companies

Australia - Belgium - Brazil - Canada - China - Czech Republic - Finland - France - Germany - Hong Kong - India - Israel - Italy - Japan - Malaysia - Malta - Morocco - Philippines - Singapore - Spain - Sweden - Switzerland - United Kingdom - United States of America

www.st.com

Mouser Electronics

Authorized Distributor

Click to View Pricing, Inventory, Delivery & Lifecycle Information:

[STMicroelectronics:](#)

[STMPE16M31PXQTR](#)