

Introduction

The STM32 Nucleo-64 boards, based on the MB1360 reference board (NUCLEO-G070RB, NUCLEO-G071RB, and NUCLEO-G0B1RE order codes) provide an affordable and flexible way for users to try out new concepts and build prototypes with the STM32 microcontroller, which provide various combinations of performance, power consumption, and features. ARDUINO® Uno V3 connectivity and ST morpho headers provide easy means of expanding the functionality of the Nucleo open development platform with a wide choice of specialized shields.

The STM32 Nucleo-64 boards do not require any separate probe, as they integrate the ST-LINK/V2-1 debugger/programmer. The STM32 Nucleo-64 boards come with the comprehensive free STM32 software libraries and examples that are available with the STM32CubeGO MCU Package.

Figure 1. STM32 Nucleo-64 board top view

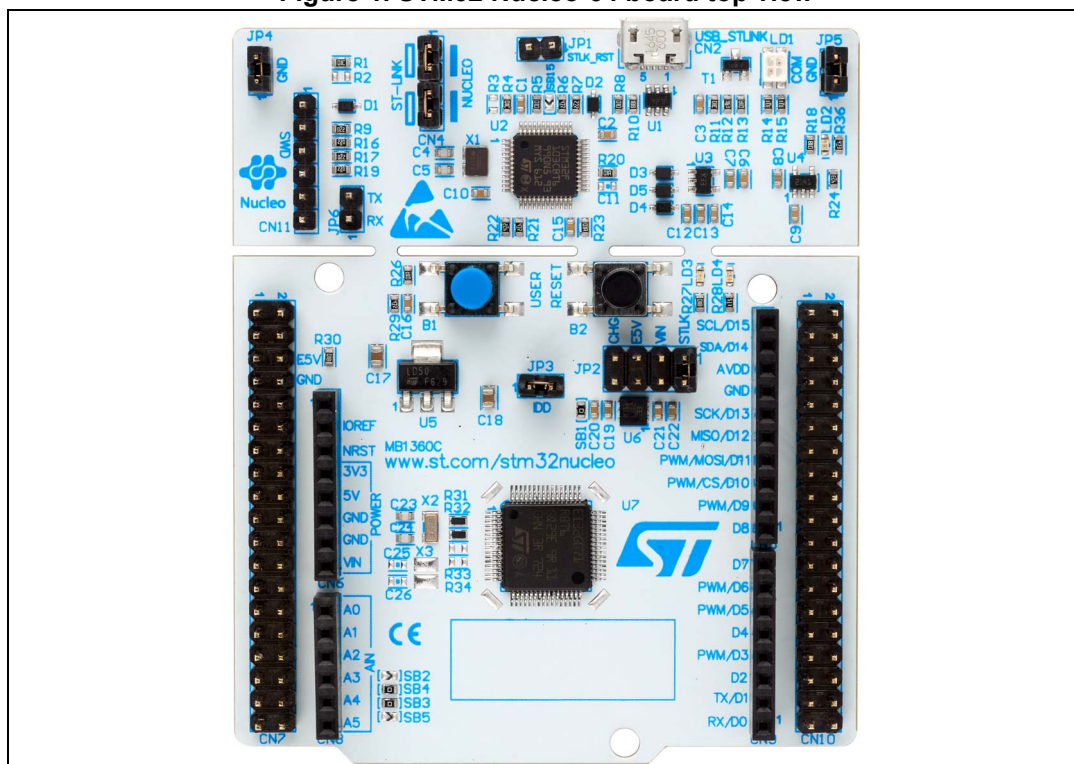

Picture is not contractual.



Contents

1	Features	7
2	Ordering information	8
	2.1 Codification	8
3	Development environment	9
	3.1 System requirements	9
	3.2 Development toolchains	9
	3.3 Demonstration software	9
4	Conventions	9
5	Quick start	10
	5.1 Getting started	10
6	Hardware layout and configuration	11
	6.1 STM32 Nucleo-64 board mechanical drawing	13
	6.2 Default board configuration	13
	6.3 Cuttable PCB	13
	6.4 Embedded ST-LINK/V2-1	14
	6.4.1 Drivers	15
	6.4.2 ST-LINK/V2-1 firmware upgrade	15
	6.4.3 Using the ST-LINK/V2-1 to program/debug the STM32 on board	15
	6.4.4 Using ST-LINK/V2-1 to program/debug an external STM32 application	16
	6.5 Power supply and power selection	17
	6.5.1 External power supply input	17
	6.5.2 External power supply output:	22
	6.6 Programming/debugging when the power supply is not from ST-LINK ..	22
	6.7 OSC clock sources	23
	6.7.1 LSE: OSC 32 kHz clock supply	23
	6.7.2 HSE: OSC 8 MHz clock supply	24
	6.8 Reset sources	24
	6.9 UART2 communication	24

6.10	LEDs	25
6.11	Push-buttons	25
6.12	I _{DD} measurement	26
6.13	Jumper configuration	26
6.14	Configuration of the solder bridges	26
7	Connectors	28
7.1	CN2 USB Micro-B connector	28
7.2	ARDUINO [®] Uno V3 connector	29
7.3	CN7 and CN10 ST morpho connectors	32
8	STM32 Nucleo-64 board information	34
8.1	Product marking	34
8.2	NUCLEO-G070RB product history	34
8.2.1	Product identification NUG070RB\$AU1	34
8.2.2	Product identification NUG070RB\$AU2	34
8.3	NUCLEO-G071RB product history	35
8.3.1	Product identification NUG071RB\$AU1	35
8.3.2	Product identification NUG071RB\$AU2	35
8.4	NUCLEO-G0B1RE product history	35
8.4.1	Product identification NUG0B1RE\$AU1	35
8.5	Board revision history	36
8.5.1	Board MB1360 revision C-01	36
8.5.2	Board MB1360 revision C-02	36
Appendix A	STM32 Nucleo-64 board I/O assignment	37
Appendix B	Federal Communications Commission (FCC) and ISED Canada Compliance Statements	39
B.1	FCC Compliance Statement	39
B.2	ISED Compliance Statement	40
Appendix C	CE conformity	41
C.1	Warning	41
C.2	Simplified declaration of conformity	41

Revision history **42**

List of tables

Table 1.	Ordering information	8
Table 2.	Codification explanation	8
Table 3.	ON/OFF conventions	9
Table 4.	Default jump settings	13
Table 5.	ST-LINK jumper configuration	14
Table 6.	CN11 debug connector (SWD)	16
Table 7.	Power supply capabilities	18
Table 8.	UART2 pins	25
Table 9.	Jumper configuration	26
Table 10.	Solder bridge configurations and settings	26
Table 11.	USB Micro-B pinout	28
Table 12.	ARDUINO® connector pinout	30
Table 13.	STM32 Nucleo-64 board I/O assignment	37
Table 14.	Document revision history	42

List of figures

Figure 1.	STM32 Nucleo-64 board top view	1
Figure 2.	Hardware block diagram	11
Figure 3.	Top layout	12
Figure 4.	Bottom layout	12
Figure 5.	STM32 Nucleo-64 board mechanical drawing	13
Figure 6.	USB composite device	15
Figure 7.	STM32 Nucleo-64 board connections image	16
Figure 8.	ST-LINK connections image	17
Figure 9.	STLK power source	19
Figure 10.	JP2 [3-4]: STLK power source	20
Figure 11.	JP2 [5-6]: STLK power source	21
Figure 12.	JP2 [7-8]: CHG power source	22
Figure 13.	CN2 USB Micro-B connector (front view)	28
Figure 14.	ARDUINO [®] connectors	29
Figure 15.	STM32 Nucleo-64 boards ARDUINO [®] connector pinout	30
Figure 16.	ST morpho connectors	32
Figure 17.	STM32 Nucleo-64 boards ST morpho connector pinout	33

1 Features

- STM32 Arm^{®(a)}-based microcontroller in LQFP64 package
- 1 user LED shared with ARDUINO[®]
- 1 user and 1 reset push-buttons
- 32.768 kHz crystal oscillator
- Board connectors:
 - ARDUINO[®] Uno V3 expansion connector
 - ST morpho extension pin headers for full access to all STM32 I/Os
- Flexible power-supply options: ST-LINK, USB V_{BUS} , or external sources
- On-board ST-LINK debugger/programmer with USB re-enumeration capability: mass storage, Virtual COM port, and debug port
- Comprehensive free software libraries and examples available with the STM32Cube MCU Package
- Support of a wide choice of Integrated Development Environments (IDEs) including IAR Embedded Workbench[®], MDK-ARM, and STM32CubeIDE



a. Arm is a registered trademark of Arm Limited (or its subsidiaries) in the US and/or elsewhere.

2 Ordering information

To order the STM32 Nucleo-64 board, refer to [Table 1](#). Additional information is available from the datasheet and reference manual of the target STM32.

Table 1. Ordering information

Order code	Board reference	Target STM32
NUCLEO-G070RB	MB1360	STM32G070RBT6
NUCLEO-G071RB		STM32G071RBT6
NUCLEO-G0B1RE		STM32G0B1RET6

2.1 Codification

The meaning of the codification is explained in [Table 2](#).

Table 2. Codification explanation

NUCLEO-XXYYRT	Description	Example: NUCLEO-G0B1RE
XX	MCU series in STM32 Arm Cortex MCUs	STM32G0 Series
YY	MCU product line in the series	STM32G0B1
R	STM32 package pin count	64 pins
T	STM32 Flash memory size: – B for 128 Kbytes – E for 512 Kbytes	512 Kbytes

3 Development environment

3.1 System requirements

- Windows® OS (7, 8, or 10), Linux® or macOS®(a)
- USB Type-A or USB Type-C® to Mini-B cable

3.2 Development toolchains

- IAR Systems- IAR Embedded Workbench®(b)
- Keil® - MDK-ARM(b)
- STMicroelectronics - STM32CubeIDE

3.3 Demonstration software

The demonstration software, included in the STM32Cube MCU Package corresponding to the on-board microcontroller, is preloaded in the STM32 Flash memory for easy demonstration of the device peripherals in standalone mode. The latest versions of the demonstration source code and associated documentation can be downloaded from www.st.com.

4 Conventions

Table 3 provides the conventions used for the ON and OFF settings in the present document.

Table 3. ON/OFF conventions

Convention	Definition
Jumper JPx ON	Jumper fitted
Jumper JPx OFF	Jumper not fitted
Jumper JPx [1-2]	Jumper fitted between Pin 1 and Pin 2
Solder bridge SBx ON	SBx connections closed by 0 Ω resistor
Solder bridge SBx OFF	SBx connections left open
Resistor Rx ON	Resistor soldered
Resistor Rx OFF	Resistor not soldered

In this document, the references for all information that is common to all sale types, are ‘STM32 Nucleo-64 board’ and ‘STM32 Nucleo-64 boards’.

a. macOS® is a trademark of Apple Inc., registered in the U.S. and other countries.

b. On Windows® only.

5 Quick start

This section describes how to start development quickly using the STM32 Nucleo-64 board.

Before installing and using the product, accept the Evaluation Product License Agreement from the www.st.com/epla web page.

For more information on the STM32 Nucleo board and to access the demonstration software, visit the www.st.com/stm32nucleo website.

5.1 Getting started

The STM32 Nucleo-64 board is a low-cost and easy-to-use development kit to quickly evaluate and start development with an STM32 microcontroller in the QFP64 package. To start using this board, follow the steps below:

1. Check the jumper position on the board, CN4 (STLK) on [1-2], [3-4], JP2 (PWR) on [1-2], JP3 (IDD) on.
2. For correct identification of all device interfaces from the host PC, install the Nucleo USB driver available on the www.st.com/stm32nucleo web page, before connecting the board.
3. To power the board, connect the STM32 Nucleo-64 board to a PC with a USB Type-A or USB Type-C[®] to Micro-B cable through the CN2 USB connector. As a result, the green LED LD3 (PWR) lights up, LD1 (COM) blinks.
4. Press user button B1 (blue).
5. Observe that the blinking frequency of the three green LED LD4 changes, by clicking on the button B1.
6. The demonstration software and several software examples that allow the user to use the Nucleo features are available at www.st.com/stm32nucleo.

6 Hardware layout and configuration

The STM32 Nucleo-64 boards are designed around the STM32 microcontrollers in a 64-pin LQFP package.

Figure 2 illustrates the connections between the STM32 and its peripherals (STLINK/V2-1, pushbutton, LED, and morpho connectors).

Figure 3 and *Figure 4* help the user to locate these features on the STM32 Nucleo-64 board.

Figure 2. Hardware block diagram

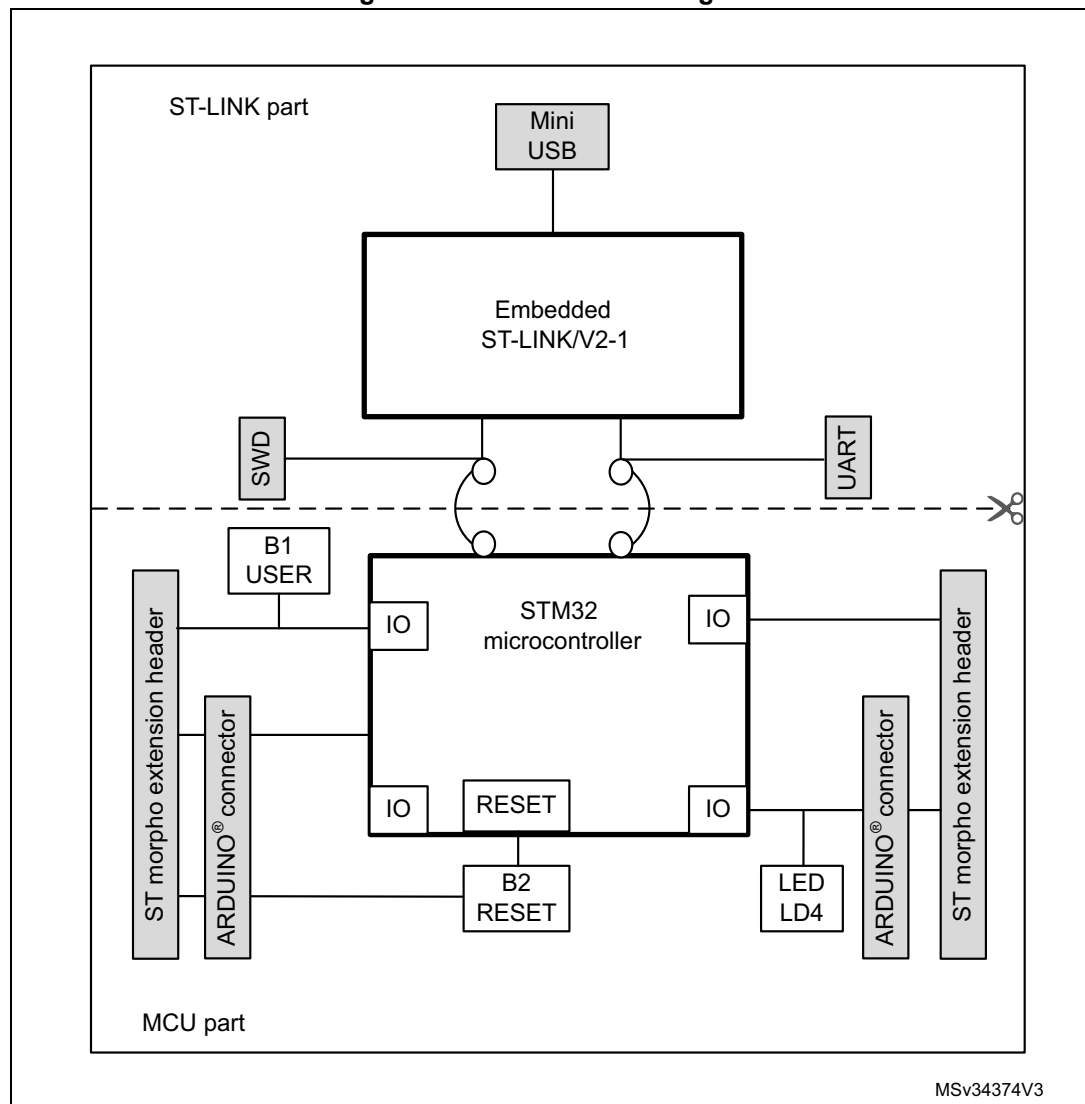

6.4 Embedded ST-LINK/V2-1

The ST-LINK/V2-1 programming and debugging tool is integrated into the Nucleo. Compared to ST-LINK/V2 the changes are listed below.

The new features supported on ST-LINK/V2-1:

- USB software re-enumeration
- Virtual COM port interface on USB
- Mass storage interface on USB
- Registers R/W interface on USB (Not available on Nucleo)
- USB power management request for more than 100 mA power on USB

The features no more supported on ST-LINK/V2-1:

- SWIM interface
- Minimum application voltage supported by Nucleo limited to 3V
- Standalone version doesn't exist (only Nucleo and future discovery support V2-1)

For all general information concerning debugging and programming features common between V2 and V2-1 refer to ST-LINK/V2 user manual (UM1075).

The embedded ST-LINK/V2-1 is usable in two different ways according to the jumper states (Refer to [Table 5](#)):

- Program/debug the STM32 on board,
- Program/debug an STM32 in an external application board using a cable connected to the SWD connector.

Table 5. ST-LINK jumper configuration

CN	Definition	Default position	Comment
CN4	T_SWCLK / T_SWDIO	ON [1-2] ON[3-4]	ST-LINK/V2-1 functions enabled for on-board programming (default)
CN4	T_SWCLK / T_SWDIO	OFF [1-2] OFF[3-4]	ST-LINK/V2-1 functions enabled from external connector (SWD supported)

6.4.1 Drivers

Before connecting the STM32 Nucleo-64 board to a Windows® PC (7, 8, or 10) through USB, install the driver for the ST-LINK/V2-1 that is available at the www.st.com website.

In case the STM32 Nucleo-64 board is connected to the PC before installing the driver, the PC device manager may report some Nucleo interfaces as 'Unknown'. To recover from this situation, after installing the dedicated driver, the association of 'Unknown' USB devices found on the STM32 Nucleo-64 board to this dedicated driver, must be updated in the device manager manually.

Note: It is recommended to proceed by using USB Composite Device, as shown in [Figure 6](#).

Figure 6. USB composite device

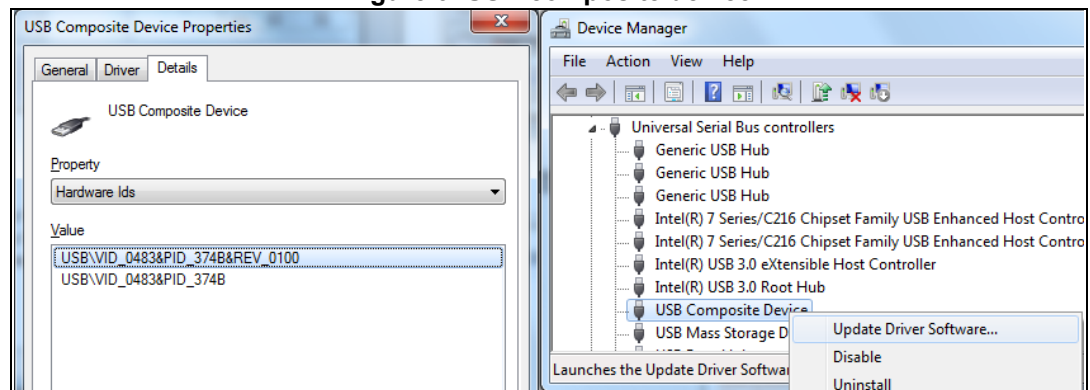

6.4.2 ST-LINK/V2-1 firmware upgrade

The ST-LINK/V2-1 embeds a firmware upgrade mechanism for the in-situ upgrade through the USB port. As the firmware may evolve during the lifetime of the ST-LINK/V2-1 product (for example new functionalities, bug fixes, support for new microcontroller families), it is recommended to keep the ST-LINK/V2-1 firmware up to date before starting to use an STM32 Nucleo-64 board. The latest version of this firmware is available at the www.st.com website.

6.4.3 Using the ST-LINK/V2-1 to program/debug the STM32 on board

To program the STM32 on board, simply plug in the two jumpers on CN4, as shown in [Figure 7](#) in pink, but do not use the CN11 connector as that may disturb communication with the STM32 microcontroller of the Nucleo.

Figure 7. STM32 Nucleo-64 board connections image

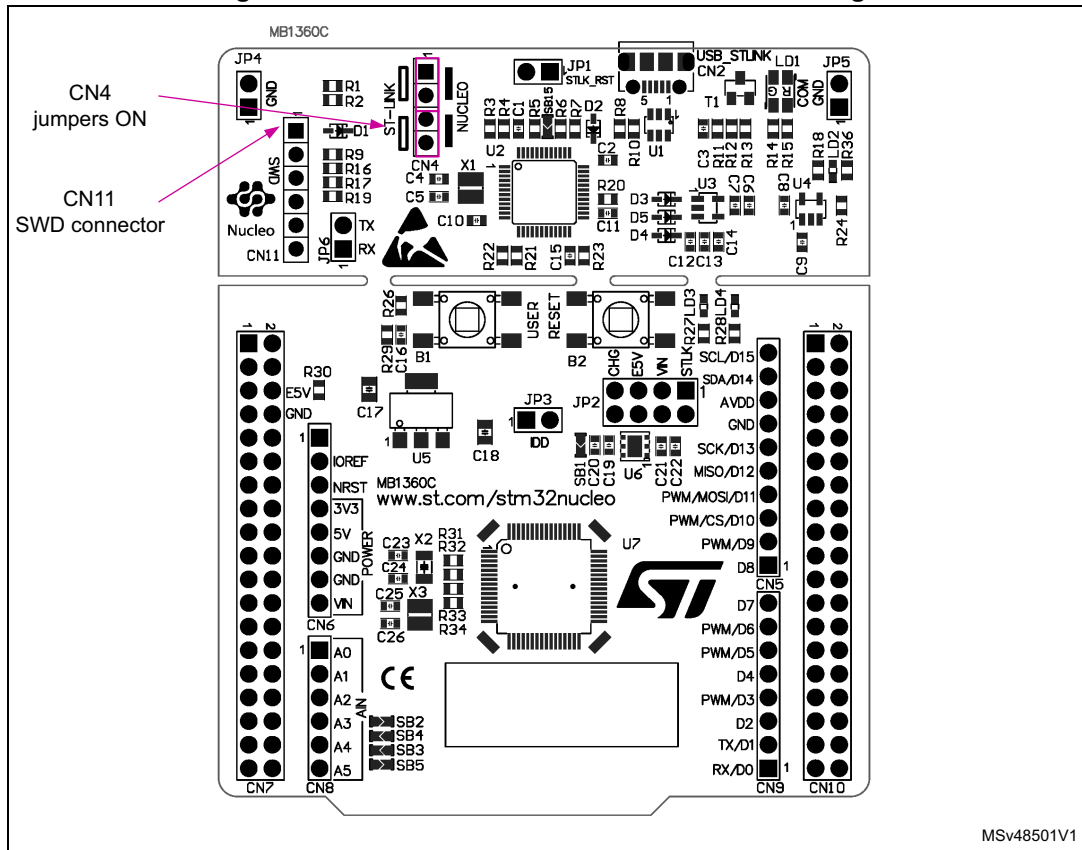

MSv48501V1

6.4.4 Using ST-LINK/V2-1 to program/debug an external STM32 application

It is easy to use the ST-LINK/V2-1 to program the STM32 on an external application. Remove the 2 jumpers from CN4 as shown in [Figure 8](#), and connect the application to the CN11 debug connector according to [Table 6](#).

Note: SB19 must be OFF if CN11 pin 5 is used in the external application.

Table 6. CN11 debug connector (SWD)

Pin	CN11	Designation
1	VDD_TARGET	VDD from the application
2	SWCLK	SWD clock
3	GND	Ground
4	SWDIO	SWD data input/output
5	NRST	RESET of target MCU
6	SWO	Reserved

Figure 8. ST-LINK connections image

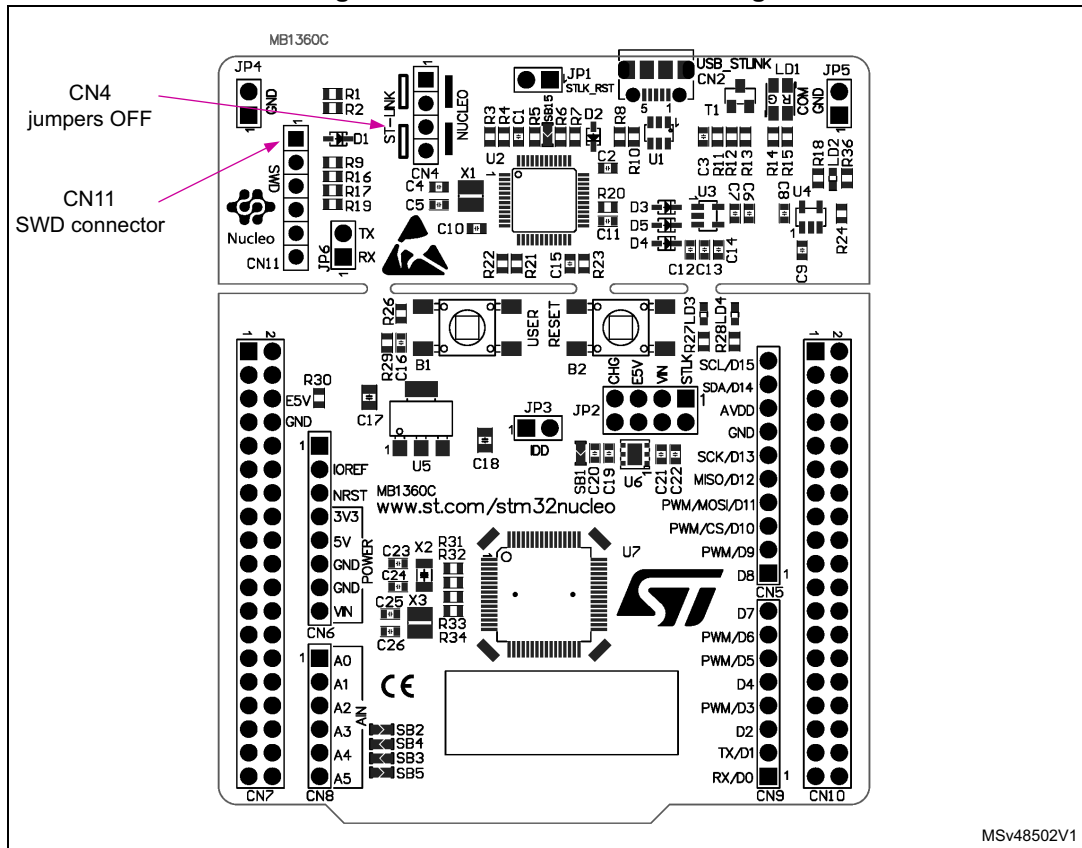

MSv48502V1

6.5 Power supply and power selection

6.5.1 External power supply input

The STM32 Nucleo-64 board is designed to be powered by several DC power supplies. It is possible to supply the STM32 Nucleo-64 board with any of the following sources:

- 5V_USB_STLK from the ST-LINK USB connector
- VIN (7 V - 12 V) from ARDUINO® connector or ST morpho connector
- E5V from ST morpho connector
- 5V_USB_CHG from the ST-LINK USB connector
- 3.3 V on ARDUINO® connector or ST morpho connector

Note: If an external 5 V DC power source is used, the Nucleo board must be powered by a power supply unit or by auxiliary equipment complying with the standard EN-60950-1: 2006+A11/2009 and must be safety extra-low voltage (SELV) with limited power capability.

The power supply capabilities are shown in [Table 7](#).

Table 7. Power supply capabilities

Input Power	Connector pins	Voltage range	Max current	Limitation
5V_USB_STLK	CN2 PIN1	4.75 V to 5.25 V	500 mA	Max current depends on the USB enumeration: – 100 mA without enumeration – 500 mA with enumeration OK
VIN	CN6 pin 8 CN7 pin 24	7 V to 12 V	800 mA	From 7 V to 12 V only and input current capability is linked to input voltage: – 800 mA input current when VIN=7 V – 450 mA input current when 7 V<VIN<9 V – 300 mA input current when 10 V>VIN>9 V – less than 300 mA input current when VIN>10 V
E5V	CN7 pin 6	4.75 V to 5.25 V	500 mA	
5V_USB_CHG	CN2 pin 1	4.75 V to 5.25 V	500 mA	Max current depends on the USB wall charger used to power the Nucleo board
3V3	CN6 pin 4 CN7 pin 16 JP3 pin 1	3 V to 3.6 V	-	Used when ST-LINK part of PCB not used or remove SB1 and SB19

5V_ST_LINK is a DC power with limitations from the ST-LINK USB connector (USB type Micro-B connector of ST-LINK/V2-1). In this case, the JP2 jumper must be on pins 1 and 2 to select the STLK power source on the JP2 silkscreen. This is the default setting. If the USB enumeration succeeds, the STLK power is enabled, by asserting the PWR_ENn signal (from STM32F103CBT6). This pin is connected to an STMP2141STR power switch, which powers the board. This power switch also features a current limitation to protect the PC in case of a short-circuit on board (more than 750 mA).

The STM32 Nucleo-64 board and its shield are powerable from the CN2 ST-LINK USB connector, but only the ST-LINK circuit is powered before USB enumeration because the host PC only provides 100 mA to the board at that time. During the USB enumeration, the STM32 Nucleo-64 board requires 500 mA of current from the host PC. If the host can provide the required power, the enumeration ends by a 'SetConfiguration' command and then, the power transistor STMP2141STR is switched ON, the green LED LD3 is turned ON, thus the STM32 Nucleo-64 board and its shield request no more than 500 mA current. If the host is not able to provide the required current, the enumeration fails. Therefore the power switch STMP2141STR stays OFF and the MCU part including the extension board is not powered. As a consequence, the green LED LD3 stays turned OFF. In this case, it is mandatory to use an external power supply.

USB power: STLINK configuration: the JP2 jumper must be connected as shown in [Figure 9](#).

Figure 9. STLK power source

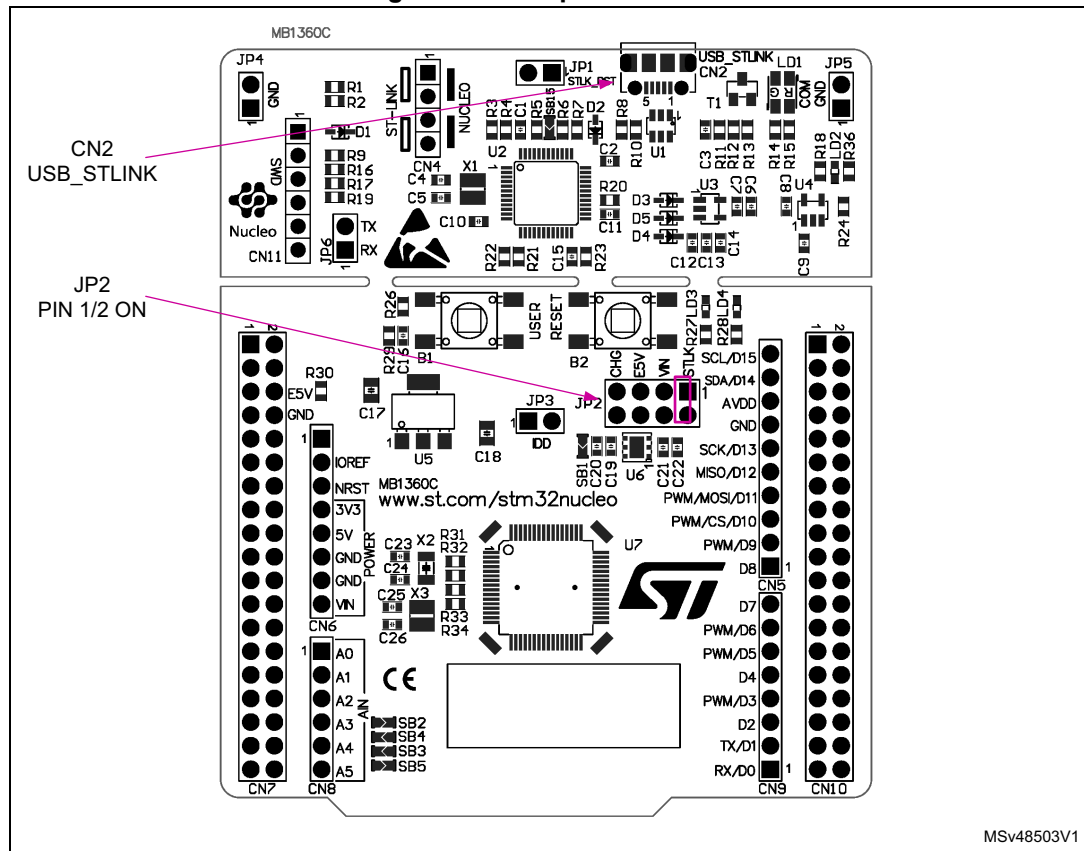

VIN is the 7 V to 12 V DC power from CN6 pin 8 named VIN on ARDUINO® connector silkscreen or from pin 24 of CN7 ST morpho connector. In this case, the JP2 jumper must be on pins 3 and 4 to select the VIN power source on the JP2 silkscreen. In that case, the DC power comes from the power supply through the ARDUINO® Uno V3 battery shield (compatible with Adafruit PowerBoost 500 shield).

VIN configuration: jumper JP2 [3-4] must be connected as shown in [Figure 10](#).

Figure 10. JP2 [3-4]: STLK power source

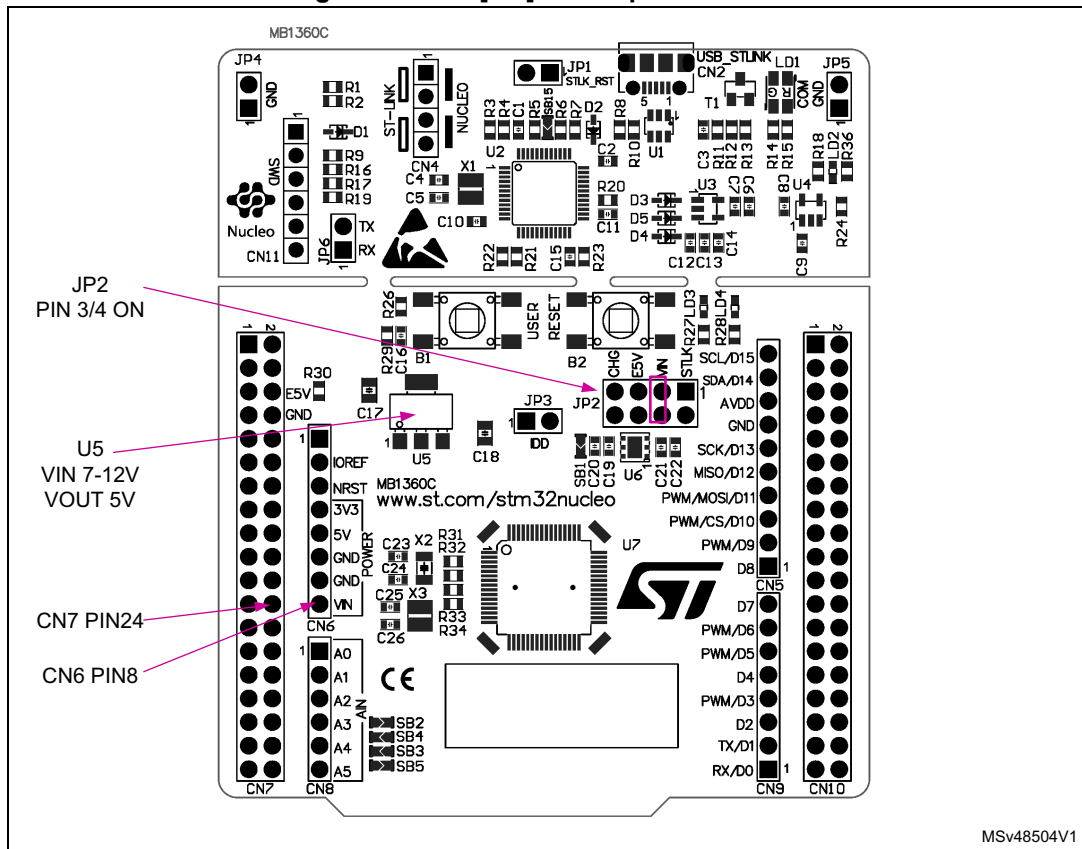

E5V is the DC power coming from external (5V DC power from pin 6 of the CN7 ST morpho connector). In this case, the JP2 jumper must be on pins 5 and 6 to select the E5V power source on the JP2 silkscreen.

E5V configuration: Jumper JP2 [5-6] must be connected as shown in [Figure 11](#).

Figure 11. JP2 [5-6]: STLK power source

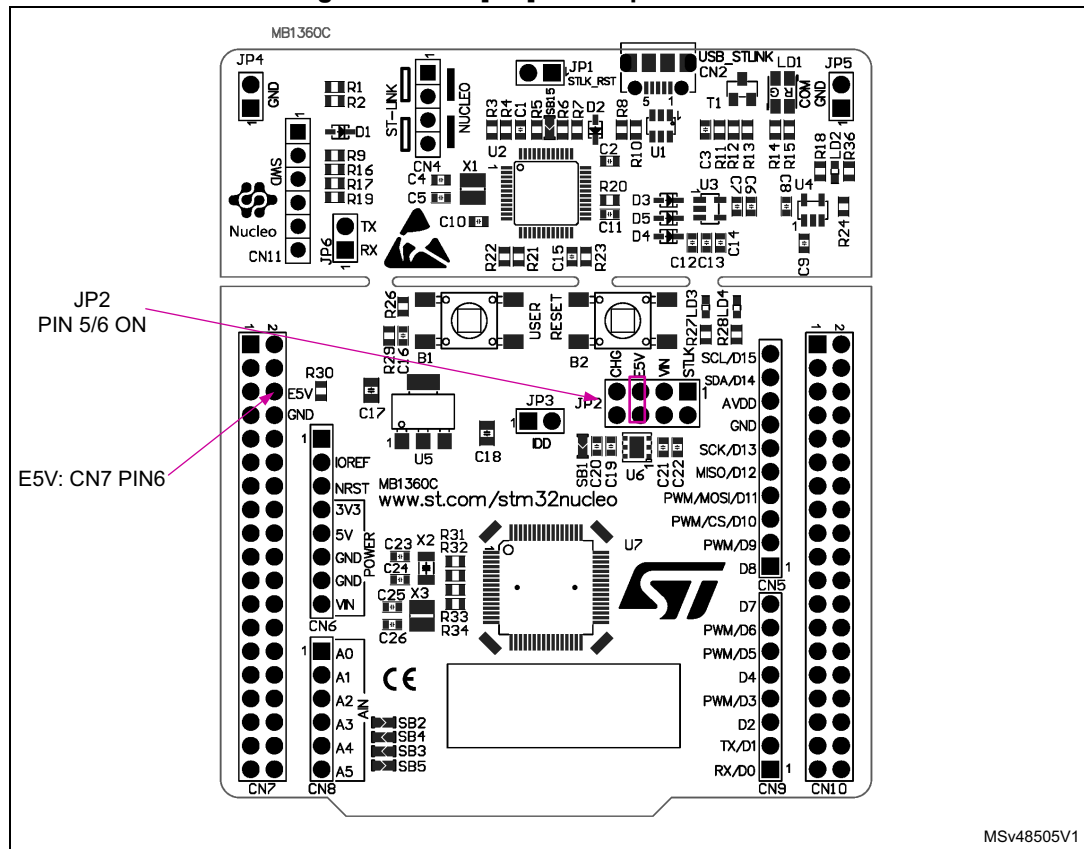

5V_USB_CHARGER is the DC power charger connected to USB ST-LINK (CN2). To select the CHG power source on the JP2 silkscreen, the JP2 jumper must be on pins 7 and 8. In this case, if the STM32 Nucleo-64 board is powered by an external USB charger the debug is not available. If the PC is connected instead of the charger, the limitation is no more effective and the PC can be damaged.

CHG configuration: jumper JP2 [7-8] must be connected as shown in [Figure 12](#).

Figure 12. JP2 [7-8]: CHG power source

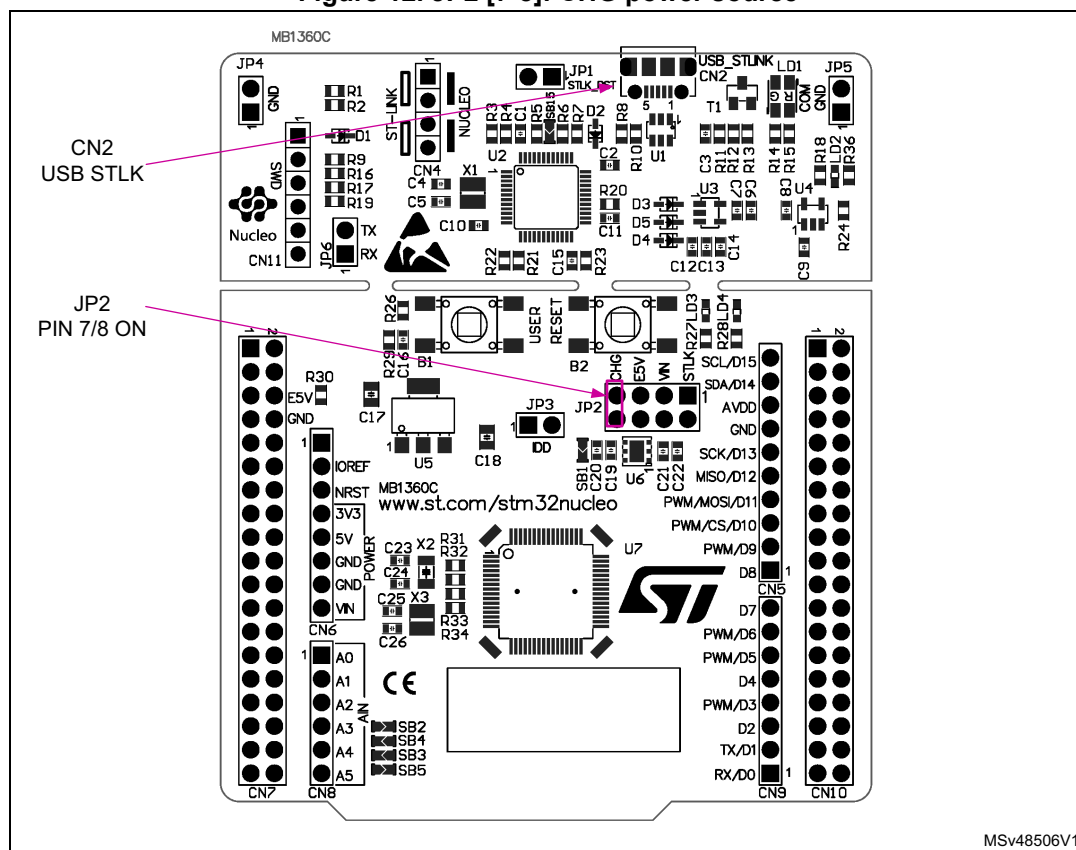

6.5.2 External power supply output:

- 5V: The 5V (CN6 pin 5 or CN7 pin 18) is usable as an output power supply for an ARDUINO® shield or an extension board when the STM32 Nucleo-64 board is powered by USB, VIN, or E5V. In this case, the maximum current allowed is shown in [Table 7](#).
- 3.3V: on CN6 pin 4 or CN7 pin 16 is usable as power supply output. The current is limited by the maximum current capability of the regulator U6 (LDL112PV33R from STMicroelectronics). In this condition, the maximum consumption of the STM32 Nucleo-64 board and the connected shield must be less than 500 mA.

6.6 Programming/debugging when the power supply is not from ST-LINK

VIN or E5V is usable as an external power supply in case the current consumption of the STM32 Nucleo-64 board and its extension boards exceed the allowed current on the USB. In such a condition, it is still possible to use the USB for communication, programming, or debugging only. In this case, it is mandatory to power the board first using VIN or E5V then to connect the USB cable to the PC. Proceeding this way the enumeration succeeds, thanks to the external power source. The following power sequence procedure must be respected:

1. Connect jumper JP2 between pins 3 and 4 for VIN or pins 5 and 6 for E5V,
2. Connect the external power source to VIN or E5V,
3. Power ON the external power supply $7\text{ V} < \text{VIN} < 12\text{ V}$ to VIN, or 5 V for E5V,
4. Check that the green LED LD3 is turned ON,
5. Connect the PC to the CN2 USB connector.

If this sequence is not respected, the board may be powered by VBUS first from the ST-LINK, with the following risks:

- If more than 500 mA current is needed by the board, the PC may be damaged or the current supplied may be limited by the PC. As a consequence, the board is not powered correctly.
- 500 mA is requested at the enumeration (since SB15 must be OFF): this request is rejectable and the enumeration does not succeed if the PC does not provide such current, consequently, the board is not power supplied (LED LD3 remains OFF).

6.7 OSC clock sources

Three clock sources are listed below:

- LSE which is the 32.768 kHz crystal for the STM32 embedded RTC
- MCO which is the 8 MHz clock from the ST-LINK MCU for the STM32 microcontroller
- HSE which is the 8 MHz oscillator for the STM32 microcontroller. This clock is not implemented on the STM32 Nucleo-64 board

6.7.1 LSE: OSC 32 kHz clock supply

There are three ways to configure the pins corresponding to the low-speed clock (LSE):

1. LSE on-board X2 crystal (Default configuration). Refer to *crystal design guide for STM8S, STM8A, and STM32 microcontrollers* application note (AN2867) for crystal design guide for STM32 microcontrollers. It is recommended to use NX3215SA manufactured by NDK (32.768 kHz, 6 pF, 20 ppm).
2. Oscillator from external to PC14 input: from external oscillator through pin 25 of the CN7 connector. The following configuration is needed:
 - SB23 ON
 - R31 and R32 removed
3. LSE not used: PC14 and PC15 are used as GPIOs instead of low-speed clocks. The following configuration is needed:
 - SB23 and SB24 ON
 - R31 and R32 removed

6.7.2 HSE: OSC 8 MHz clock supply

There are four ways to configure the pins corresponding to the external high-speed clock (HSE):

- HSE not used (default): PF0 and PF1 are used as GPIOs instead of clocks. The configuration must be:
 - SB25 and SB27 ON
 - SB17 (MCO) OFF
 - R33 and R34 OFF
- MCO from ST-LINK: MCO output of ST-LINK is used as an input clock. This frequency cannot be changed, it is fixed at 8 MHz and connected to the PF0-OSC_IN of the STM32 microcontroller. The configuration must be:
 - SB17 ON
 - SB25 and SB27 OFF
 - R33 and R34 OFF
- HSE on-board oscillator from X3 crystal (not provided): for typical frequencies, capacitors, and resistors, refer to the STM32 microcontroller datasheet and the *Oscillator design guide for STM8S, STM8A, and STM32 microcontrollers* application note (AN2867) for the oscillator design guide. The X3 crystal has the following characteristics: 8 MHz, 8 pF, 20 ppm. It is recommended to use NX3225GD-8.000M-EXS00A-CG04874 manufactured by NIHON DEMPA KOGYO CO., LTD. The configuration must be:
 - SB25 and SB27 OFF
 - R33 and R34 soldered
 - C24 and C25 soldered with 10 pF capacitors
 - SB17 OFF
- Oscillator from external PF0: from an external oscillator through pin 29 of the CN7 connector. The configuration must be:
 - SB25 ON
 - SB17 OFF
 - R33 and R34 removed

6.8 Reset sources

The reset signal of the STM32 Nucleo-64 board is active low and the reset sources include:

- B2 Reset button
- Embedded ST-LINK/V2-1
- Pin 3 of the CN6 ARDUINO® Uno V3 connector
- Pin 14 of the CN7 ST morpho connector

6.9 UART2 communication

The UART2 interface of the STM32 is connectible to:

- The ST-LINK/V2-1 MCU
- The ST morpho connector (CN10 pin 6 and pin 34)

Table 8. UART2 pins

Pin name	Function	Virtual COM port (default configuration)	ST morpho connection
PA2	UART2 TX	SB16 ON	SB16 OFF
PA3	UART2 RX	SB18 ON	SB18 OFF

6.10 LEDs

Four LEDs are available on the STM32 Nucleo-64 board. The four LEDs are located on the top side of the board.

- LD1 COM: LD1 is a bi-colored LED. the LD1 default status is red. LD1 turns to green to indicate that communication is in progress between the PC and the ST-LINK/V2-1 as follow:
 - Slow blinking red and off: at power-on before USB initialization
 - Fast blinking red and off: after the first correct communication between the PC and the STLINK/V2-1 (enumeration)
 - Red LED on: when initialization between the PC and the ST-LINK/V2-1 is successfully ended
 - Green LED on: after successful STM32 communication initialization
 - Blinking red and green: during communication with STM32
 - Green on: communication well ended
 - Orange on: communication ended with failure
- LD2: 5V_USB_CHG: this red LED is ON when overcurrent is detected on USB VBUS. The LED gives the information that more than 500 mA is requested on VBUS. In this case, it is recommended to supply the board with E5V, VIN, or in USB_CHARGER mode.
- LD3: 5V_PWR: this green LED is ON when the STM32 Nucleo-64 board is powered by a 5 V source.
- LD4 USER: this green LED is a user LED connected to ARDUINO® signal D13 corresponding to STM32 I/O PA5. To light the LED a high-logic state '1' has to be written in the corresponding GPIO. A transistor is used to drive the LED when the I/O voltage is 1.8 V. LD4 consumption does not impact the VDD STM32 power measurement, since LD4 is isolated from it.

6.11 Push-buttons

- B1 USER: User and Wake-Up button connected to the I/O PC13 (Pin 3) of the STM32 Microcontroller.
- B2 RESET: Pushbutton connected to NRST is used to RESET the STM32 Microcontroller.

The blue and black plastic hats placed on these pushbuttons are removable if necessary when a shield or an application board is plugged on top of Nucleo. This avoids pressure on the buttons and consequently a possible permanent Target MCU RESET.

6.12 I_{DD} measurement

The JP3 labeled-IDD jumper allows the consumption of the STM32 Microcontroller to be measured by removing the jumper and connecting an ammeter.

- Jumper ON: STM32 Microcontroller is powered (default).
- Jumper OFF: an ammeter must be connected to measure the STM32 microcontroller current. If there is no ammeter, the STM32 microcontroller is not powered.

6.13 Jumper configuration

The default jumper positions are shown in [Table 4](#). [Table 9](#) describes the other available jumper settings.

Table 9. Jumper configuration

Jumper / CN	Function	State ⁽¹⁾	Comment
CN4	T_SWCLK T_SWDIO	ON [1-2] ON [3-4]	ST-LINK/V2-1 enable for on-board MCU debugger
		OFF [1-2] OFF [3-4]	ST-LINK/V2-1 functions enabled for external CN2 connector
JP4/JP5	GND	ON	GND probe
JP2	5 V Power selection	ON [1-2]	5 V from ST-LINK
		ON [3-4]	5 V from VIN 7 V to 12 V
		ON [5-6]	5 V from E5V
		ON [7-8]	5 V from USB_CHG
		OFF	No 5 V power
JP1	STLK Reset	ON [1-2]	STLK Reset
		OFF	No STLK Reset
JP3	I _{DD} measurement	ON [1-2]	VDD = 3.3 V
		OFF	To connect the external source (ULPBench probe as an example)

1. Default jumper state is shown in bold.

6.14 Configuration of the solder bridges

[Table 10](#) shows the solder bridge configurations and settings.

Table 10. Solder bridge configurations and settings

Definition	Bridge	State ⁽¹⁾	Comment
SWD interface (default)	SB7/SB9 /SB11/SB13	ON	Reserved, do not modify.
SWD interface (reserved)	SB6/SB8 /SB10/SB12	OFF	Reserved, do not modify.

Table 10. Solder bridge configurations and settings (continued)

Definition	Bridge	State ⁽¹⁾	Comment
UART2 interface (reserved)	SB16/SB18	ON	UART2 connect STLK and MCU on board
UART2 interface (reserved)	SB16/SB18	OFF	UART2 is used as GPIOs
Allowed current through CN2 Setting	SB15	ON	Allowed current through CN2: 100 mA max
		OFF	Allowed current through CN2: 300 mA max
MCO	SB17	ON	MCO from STLK provide 8 MHz CLK to MCU
		OFF	MCO from STLK floating
3.3 V LDO output	SB1	ON	U6 LDO output provides 3.3 V
		OFF	U6 LDO output does not provide 3.3 V
Power (reserved)	SB29/SB30	ON	PD8 is used as VDD, PD9 is used as GND
		OFF	PD8 and PD9 is used as GPIOs
VBAT	SB26	ON	VDD provides power to VBAT
		OFF	VDD does not provide power to VBAT
AVDD	SB28	ON	VDD provides power to AVDD
		OFF	VDD does not provide power to AVDD
AGND	SB31	ON	AGND connects to GND
		OFF	AGND does not connect to GND
HSE CLK selection	SB25/SB27	ON(R33/R34 OFF)	PF0/PF1 works as GPIOs
		OFF	PF0/PF1 works as HSE pins
LSE CLK selection	SB23/SB24	ON(R31/R32 OFF)	PC14/PC15 works as GPIOs
		OFF	PC14/PC15 works as LSE pins
ADC/IIC	SB2/SB3/SB4/SB5	SB3/SB4 ON, SB2/SB5 OFF	CN8 PIN5/6 works as ADC
		SB3/SB4 OFF, SB2/SB5 ON	CN8 PIN5/6 works as IIC
User LED	SB22	ON	PA5 controls LD4
		OFF	LD4 is isolated
AVDD	SB21	ON	AVDD connects to CN5 PIN8
		OFF	AVDD disconnects to CN5 PIN8

1. Default jumper state is shown in bold.

7 Connectors

Seven connectors are implemented on the STM32 Nucleo-64 board:

- CN2: ST-LINK USB connector
- CN5, CN6, CN8, and CN9: ARDUINO® Uno V3 connector
- CN7 and CN10: ST morpho connectors

7.1 CN2 USB Micro-B connector

The CN2 USB connector is used to connect the embedded ST-LINK/V2-1 to the PC for programming and debugging the STM32 Nucleo-64 board microcontroller.

Figure 13. CN2 USB Micro-B connector (front view)

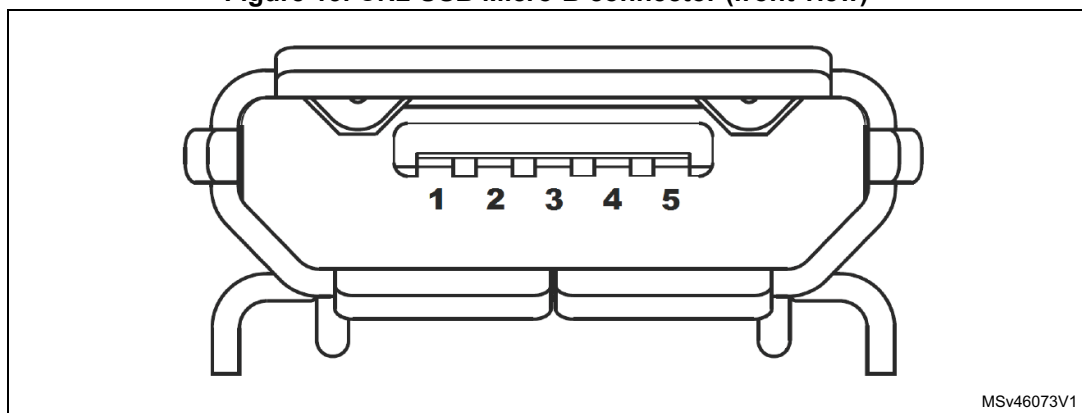

MSv46073V1

The related pinout for the USB ST-LINK connector is listed in [Table 11](#).

Table 11. USB Micro-B pinout

Connector	Pin number	Pin name	Signal name	ST-LINK MCU pin	Function
CN2	1	VBUS	5V_STLINK / 5V_USB_CHG	-	5 V power
	2	DM (D-)	STLINK_USB_D_N	PA11	USB diff. pair M
	3	DP (D+)	STLINK_USB_D_P	PA12	USB diff. pair P
	4	ID	-	-	-
	5	GND	-	-	GND

7.2 ARDUINO® Uno V3 connector

The CN5, CN6, CN8, and CN9 ARDUINO® connectors in *Figure 14* are female connectors compatible with the ARDUINO® standard. Most shields designed for ARDUINO® fit the STM32 Nucleo-64 board.

The ARDUINO® connectors on the STM32 Nucleo-64 board support the ARDUINO® Uno V3.

Figure 14. ARDUINO® connectors

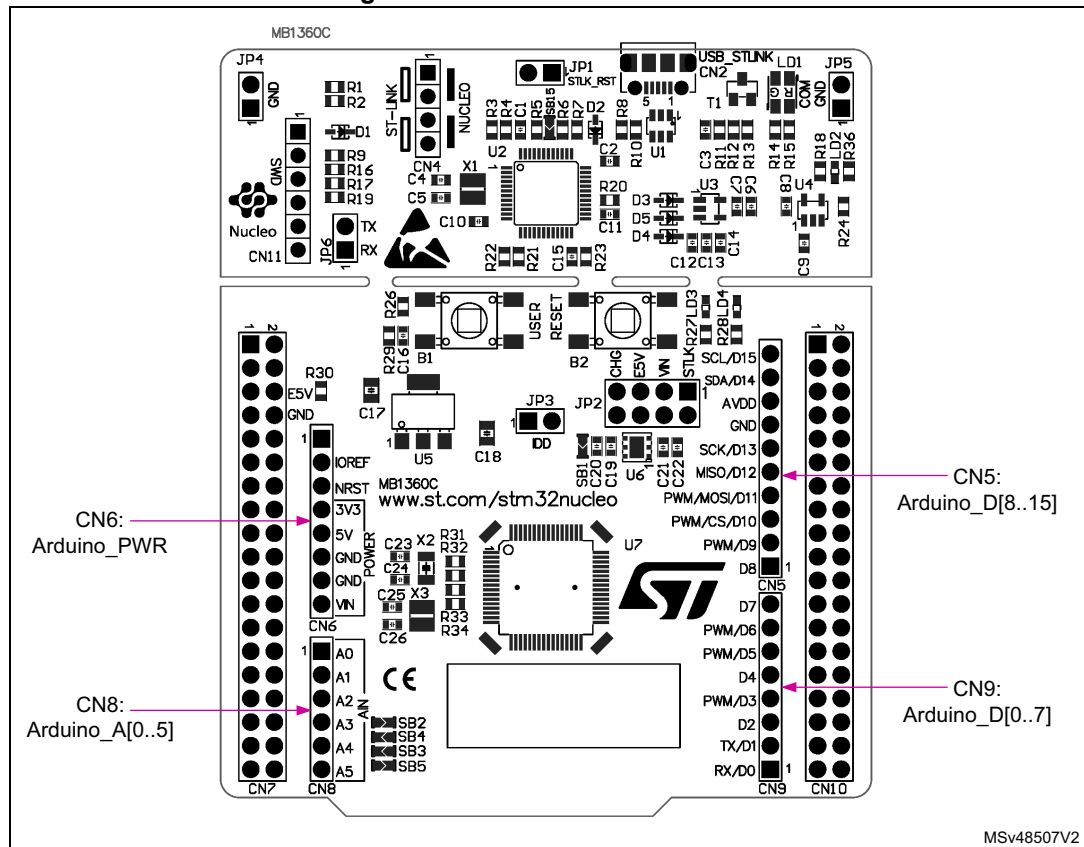

The related pinout for the ARDUINO® connector is shown in *Figure 15* and *Figure Note*: and listed in *Table 12*.

Figure 15. STM32 Nucleo-64 boards ARDUINO® connector pinout

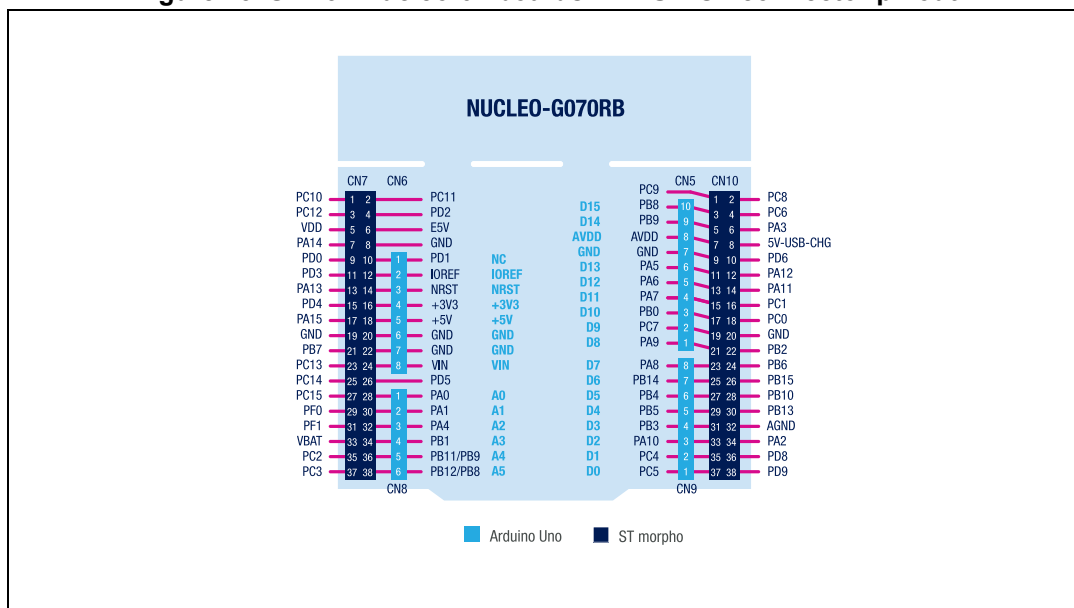

Note: ARDUINO® Uno V3 D0 and D1 signals are connected by default on USART1 (MCU I/O PC4 and PC5).

Table 12. ARDUINO® connector pinout

Connector	Pin number	Pin name	Signal name	STM32 pin	Function
CN6	1	NC	-	-	Reserved for test
	2	IOREF	-	-	I/O reference
	3	NRST	NRST	NRST	RESET
	4	3V3	-	-	3.3 V input/output
	5	5V	-	-	5 V output
	6	GND	-	-	GND
	7	GND	-	-	GND
	8	VIN	-	-	7 V to 12 V power input
CN8	1	A0	ADC	PA0	ARD_A0_IN0
	2	A1	ADC	PA1	ARD_A1_IN1
	3	A2	ADC	PA4	ARD_A2_IN4
	4	A3	ADC	PB1	ARD_A3_IN9
	5	A4	ADC	PB9 or PB11	ARD_A4_IN15 I2C_1_SCL
	6	A5	ADC	PB8 or PB12	ARD_A5_IN16 I2C_1_SDA

Table 12. ARDUINO® connector pinout (continued)

Connector	Pin number	Pin name	Signal name	STM32 pin	Function
CN5	10	SCL/D15	ARD_D15	PB8	I2C_1_SCL
	9	SDA/D14	ARD_D14	PB9	I2C_1_SDA
	8	AVDD	VREF+	-	VREF+
	7	GND	-	-	GND
	6	SCK/D13	ARD_D13	PA5	SPI_1_SCK
	5	MISO/D12	ARD_D12	PA6	SPI_1_MISO
	4	PWM/MOSI/D11	ARD_D11	PA7	SPI_1_MOSI TIM_14_CH1
	3	PWM/CS/D10	ARD_D10	PB0	SPI_1_NSS TIM_3_CH3
	2	PWM/D9	ARD_D9	PC7	TIM_3_CH2
1	D8	ARD_D8	PA9	IO	
CN9	8	D7	ARD_D7	PA8	IO
	7	PWM/D6	ARD_D6	PB14	TIM_15_CH1
	6	PWM/D5	ARD_D5	PB4	TIM_3_CH1
	5	D4	ARD_D4	PB5	IO
	4	PWM/D3	ARD_D3	PB3	TIM_1_CH2
	3	D2	ARD_D2	PA10	IO
	2	TX/D1	ARD_D1	PC4	UART_1_TX
	1	RX/D0	ARD_D0	PC5	UART_1_RX

7.3 CN7 and CN10 ST morpho connectors

The CN7 and CN10 ST morpho connectors are male pin headers accessible on both sides of the STM32 Nucleo-64 board (see *Figure 16*). All signals and power pins, except VDD_CORE 1.2 V of the STM32, are available on the ST morpho connectors. These connectors can also be probed by an oscilloscope, logical analyzer, or voltmeter.

Figure 16. ST morpho connectors

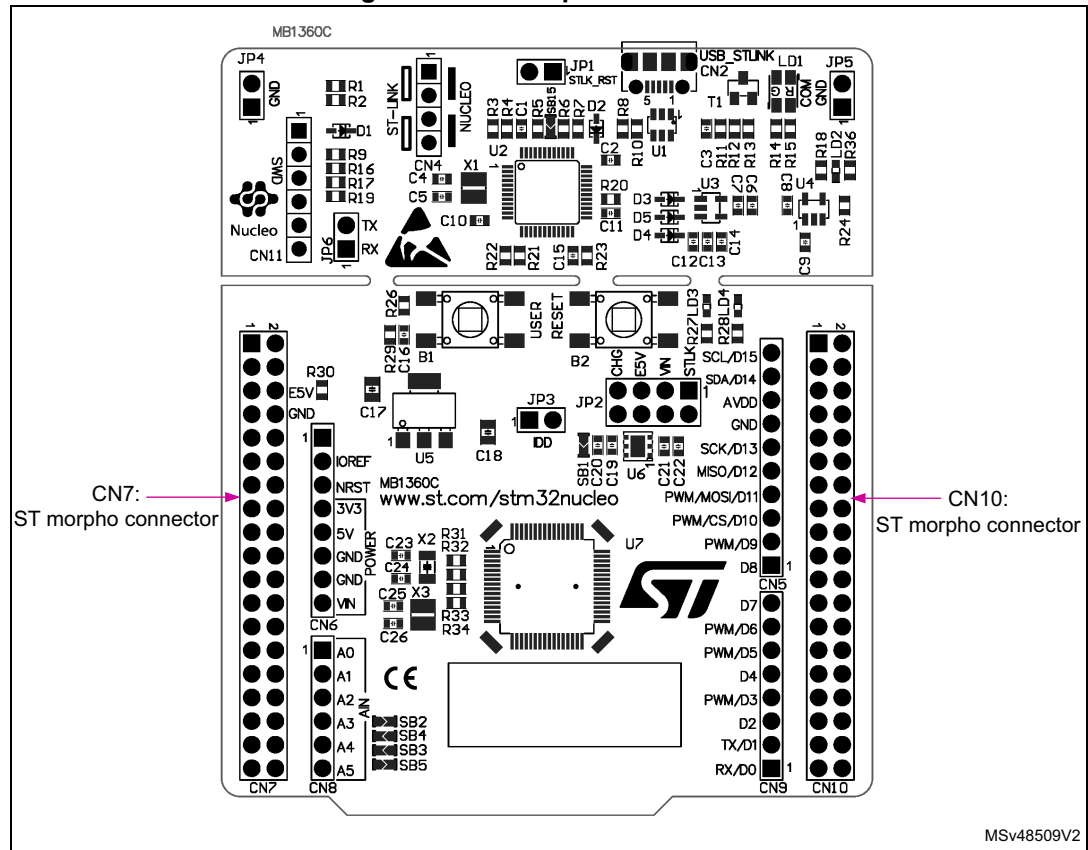

MSv48509V2

The related pinout and the MCU assignment for the ST morpho connectors are listed in [Figure 17](#) and [Figure Note](#).

Figure 17. STM32 Nucleo-64 boards ST morpho connector pinout

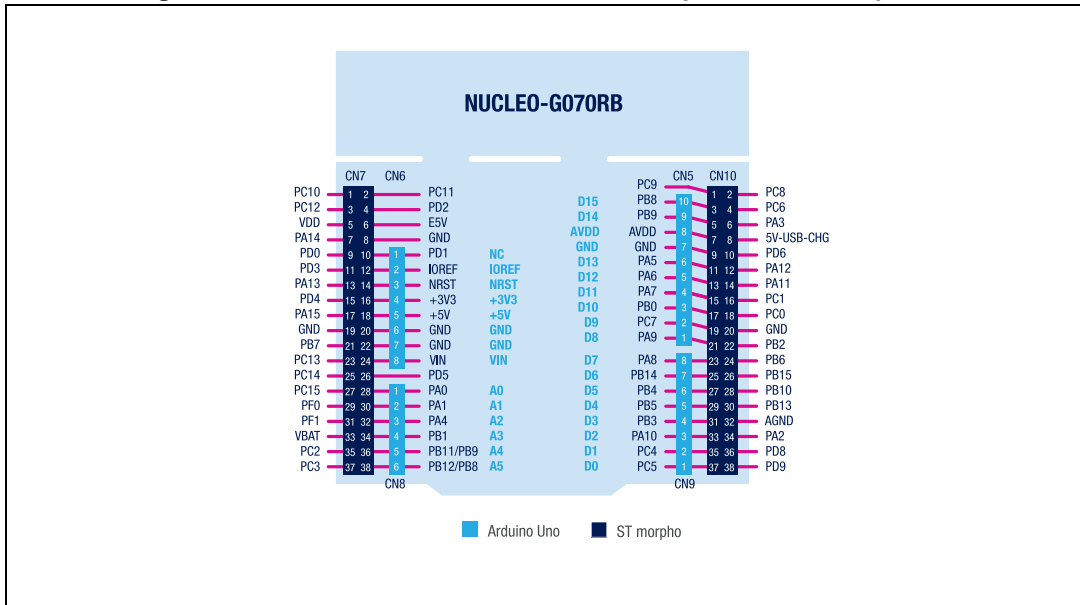

Note: ARDUINO® Uno V3 D0 and D1 signals are connected by default on USART1 (MCU I/O PA2 and PA3).

8 STM32 Nucleo-64 board information

8.1 Product marking

The stickers located on the top or bottom side of the PCB provide product information:

- Product order code and product identification for the first sticker
- Board reference with revision, and serial number for the second sticker

On the first sticker, the first line provides the product order code, and the second line the product identification.

On the second sticker, the first line has the following format: "MBxxxx-Variant-yzz", where "MBxxxx" is the board reference, "Variant" (optional) identifies the mounting variant when several exist, "y" is the PCB revision and "zz" is the assembly revision, for example B01. The second line shows the board serial number used for traceability.

Evaluation tools marked as "ES" or "E" are not yet qualified and therefore not ready to be used as reference design or in production. Any consequences deriving from such usage will not be at ST charge. In no event, ST will be liable for any customer usage of these engineering sample tools as reference designs or in production.

"E" or "ES" marking examples of location:

- On the targeted STM32 that is soldered on the board (For an illustration of STM32 marking, refer to the STM32 datasheet "Package information" paragraph at the www.st.com website).
- Next to the evaluation tool ordering part number that is stuck or silk-screen printed on the board.

Some boards feature a specific STM32 device version, which allows the operation of any bundled commercial stack/library available. This STM32 device shows a "U" marking option at the end of the standard part number and is not available for sales.

In order to use the same commercial stack in his application, a developer may need to purchase a part number specific to this stack/library. The price of those part numbers includes the stack/library royalties.

8.2 NUCLEO-G070RB product history

8.2.1 Product identification NUG070RB\$AU1

This product identification is based on the MB1360-G070RB-C01 board.

It embeds the STM32G070RBT6 microcontroller with silicon revision code "B". The limitations of this silicon revision are detailed in the errata sheet *STM32G070CB/KB/RB device errata* (ES0468).

Product limitations

No limitation identified for this product identification.

8.2.2 Product identification NUG070RB\$AU2

This product identification is based on the MB1360-G070RB-C02 board.

It embeds the STM32G070RBT6 microcontroller with silicon revision code "B". The limitations of this silicon revision are detailed in the errata sheet *STM32G070CB/KB/RB device errata* (ES0468).

Product limitations

No limitation identified for this product identification.

8.3 NUCLEO-G071RB product history

8.3.1 Product identification NUG071RB\$AU1

This product identification is based on the MB1360-G071RB-C01 board.

It embeds the STM32G071RBT6 microcontroller with silicon revision code "B". The limitations of this silicon revision are detailed in the errata sheet *STM32G071xx device errata* (ES0418).

Product limitations

No limitation identified for this product identification.

8.3.2 Product identification NUG071RB\$AU2

This product identification is based on the MB1360-G071RB-C02 board.

It embeds the STM32G071RBT6 microcontroller with silicon revision code "B". The limitations of this silicon revision are detailed in the errata sheet *STM32G071xx device errata* (ES0418).

Product limitations

No limitation identified for this product identification.

8.4 NUCLEO-G0B1RE product history

8.4.1 Product identification NUG0B1RE\$AU1

This product identification is based on the MB1360-G0B1RE-C02 board.

It embeds the STM32G0B1RET6 microcontroller with silicon revision code "A". The limitations of this silicon revision are detailed in the errata sheet *STM32G0B1xB/xC/xE device errata* (ES0548).

Product limitations

No limitation identified for this product identification.

8.5 Board revision history

8.5.1 Board MB1360 revision C-01

The revision C-01 is the initial release of the MB1360 board.

This revision C-01 is produced with the STM32G070RBT6 or STM32G071RBT6 microcontroller.

Board limitations

No limitation identified for this board revision.

8.5.2 Board MB1360 revision C-02

C23 and C24 are modified from 5.6 pF to 6.8 pF.

T2 is modified from BSN20 to BSN20BK.

This revision C-02 is produced with the STM32G070RBT6, STM32G071RBT6, or the latest STM32G0B1RET6 microcontroller.

Board limitations

No limitation identified for this board revision.

Appendix A STM32 Nucleo-64 board I/O assignment

Table 13. STM32 Nucleo-64 board I/O assignment

Pin No	Pin name	Signal or label	Main feature / optional feature (SB)
1	PC11	PC11	IO
2	PC12	PC12	IO
3	PC13	PC13	User Button/IO
4	PC14 - OSC32_IN	PC14 - OSC32_IN	LSE CLK/IO
5	PC15 - OSC32_OUT	PC15 - OSC32_OUT	LSE CLK/IO
6	PF3 - VBAT	VBAT	PWR VBAT
7	PF4 - VREF+	AVDD	PWR AVDD
8	VDD_1	VDD	PWR VDD
9	VSS_1	GND	PWR GND
10	PF0 - OSC_IN	PF0 - OSC_IN	HSE CLK/IO
11	PF1 - OSC_OUT	PF1 - OSC_OUT	HSE CLK/IO
12	PF2 - NRST	PF2 - NRST	RESET
13	PC0	PC0	IO
14	PC1	PC1	IO
15	PC2	PC2	IO
16	PC3	PC3	IO
17	PA0	PA0	ARD_A0_IN0
18	PA1	PA1	ARD_A1_IN1
19	PA2	UART2_TX	STLK_RX
20	PA3	UART2_RX	STLK_TX
21	PA4	PA4	ARD_A2_IN4
22	PA5	PA5	ARD_D13 SPI_1_SCK
23	PA6	PA6	ARD_D12 SPI_1_MISO
24	PA7	PA7	ARD_D11 SPI_1_MOSI TIM_14_CH1
25	PC4	PC4	ARD_D1 UART_1_TX
26	PC5	PC5	ARD_D0 UART_1_RX
27	PB0	PB0	ARD_D10 SPI_1_NSS TIM_3_CH3
28	PB1	PB1	ARD_A3_IN9
29	PB2	PB2	IO
30	PB10	PB10	IO
31	PB11	PB11	ARD_A4_IN15
32	PB12	PB12	ARD_A5_IN16

Table 13. STM32 Nucleo-64 board I/O assignment (continued)

Pin No	Pin name	Signal or label	Main feature / optional feature (SB)
33	PB13	PB13	IO
34	PB14	PB14	ARD_D6 TIM_15_CH1
35	PB15	PB15	IO
36	PA8	PA8	ARD_D7
37	PA9	PA9	ARD_D8
38	PC6	PC6	IO
39	PC7	PC7	ARD_D9 TIM_3_CH2
40	PD8	PD8	IO
41	PD9	PD9	IO
42	PA10	PA10	ARD_D2
43	PA11	PA11	IO
44	PA12	PA12	IO
45	PA13	TMS	SWDIO
46	PA14 - BOOT0	TCK	SWCLK
47	PA15	PA15	IO
48	PC8	PC8	IO
49	PC9	PC9	IO
50	PD0	PD0	IO
51	PD1	PD1	IO
52	PD2	PD2	IO
53	PD3	PD3	IO
54	PD4	PD4	IO
55	PD5	PD5	IO
56	PD6	PD6	IO
57	PB3	PB3	ARD_D3 TIM_1_CH2
58	PB4	PB4	ARD_D5 TIM_3_CH1
59	PB5	PB5	ARD_D4
60	PB6	PB6	IO
61	PB7	PB7	IO
62	PB8	PB8	ARD_D15 I2C_1_SCL
63	PB9	PB9	ARD_D14 I2C_1_SDA
64	PC10	PC10	IO

Appendix B Federal Communications Commission (FCC) and ISED Canada Compliance Statements

B.1 FCC Compliance Statement

Part 15.19

This device complies with Part 15 of the FCC Rules. Operation is subject to the following two conditions: (1) this device may not cause harmful interference, and (2) this device must accept any interference received, including interference that may cause undesired operation.

Part 15.21

Any changes or modifications to this equipment not expressly approved by STMicroelectronics may cause harmful interference and void the user's authority to operate this equipment.

Part 15.105

This equipment has been tested and found to comply with the limits for a Class B digital device, pursuant to part 15 of the FCC Rules. These limits are designed to provide reasonable protection against harmful interference in a residential installation. This equipment generates uses and can radiate radio frequency energy and, if not installed and used in accordance with the instructions, may cause harmful interference to radio communications. However, there is no guarantee that interference will not occur in a particular installation. If this equipment does cause harmful interference to radio or television reception, which can be determined by turning the equipment off and on, the user is encouraged to try to correct the interference by one or more of the following measures:

- Reorient or relocate the receiving antenna.
- Increase the separation between the equipment and the receiver.
- Connect the equipment into an outlet on a circuit different from that to which the receiver is connected.
- Consult the dealer or an experienced radio/TV technician for help.

Note: Use only shielded cables.

Responsible party (in the USA)

Terry Blanchard
Americas Region Legal | Group Vice President and Regional Legal Counsel, The Americas
STMicroelectronics, Inc.
750 Canyon Drive | Suite 300 | Coppell, Texas 75019
USA
Telephone: +1 972-466-7845

B.2 ISED Compliance Statement

This device complies with FCC and ISED Canada RF radiation exposure limits set forth for general population for mobile application (uncontrolled exposure). This device must not be collocated or operating in conjunction with any other antenna or transmitter.

Compliance Statement

Notice: This device complies with ISED Canada licence-exempt RSS standard(s). Operation is subject to the following two conditions: (1) this device may not cause interference, and (2) this device must accept any interference, including interference that may cause undesired operation of the device.

ISED Canada ICES-003 Compliance Label: CAN ICES-3 (B) / NMB-3 (B).

Déclaration de conformité

Avis: Le présent appareil est conforme aux CNR d'ISDE Canada applicables aux appareils radio exempts de licence. L'exploitation est autorisée aux deux conditions suivantes : (1) l'appareil ne doit pas produire de brouillage, et (2) l'utilisateur de l'appareil doit accepter tout brouillage radioélectrique subi, même si le brouillage est susceptible d'en compromettre le fonctionnement.

Étiquette de conformité à la NMB-003 d'ISDE Canada : CAN ICES-3 (B) / NMB-3 (B).

Appendix C CE conformity

C.1 Warning

EN 55032 / CISPR32 (2012) Class B product

Warning: this device is compliant with Class B of EN 55032 / CISPR32. In a residential environment, this equipment may cause radio interference.

Avertissement : cet équipement est conforme à la Classe B de la EN 55032 / CISPR 32. Dans un environnement résidentiel, cet équipement peut créer des interférences radio.

C.2 Simplified declaration of conformity

Hereby, STMicroelectronics declares that the radio equipment types NUCLEO-G070RB and NUCLEO-G071RB comply with the applicable CE requirements stated below:

- EN 55032 (2012) / EN 55024 (2010)
- EN 60950-1 (2006 + A11/2009 + A1/2010 + A12/2011 + A2/2013)

Hereby, STMicroelectronics declares that the radio equipment type NUCLEO-G0B1REB complies with the applicable CE requirements stated below:

- EN 55032 (2012/2015) / EN 55035 (2017)
- EN 60950-1 (2006 + A11/2009 + A1/2010 + A12/2011 + A2/2013)
/ EN 62368-1 (2014 +A1/2017)

The complete declaration of conformity is available upon request from STMicroelectronics.

Revision history

Table 14. Document revision history

Date	Revision	Changes
24-Oct-2018	1	Initial version
26-Oct-2018	2	Added NUCLEO-G070RB board
19-Nov-2020	3	Added NUCLEO-G0B1RE board Entire document reorganized – Updated: Introduction , Features , Ordering information , Development environment , Development toolchains , and Demonstration software . – Added: Codification , Section 8: STM32 Nucleo-64 board information , Appendix B: Federal Communications Commission (FCC) and ISED Canada Compliance Statements , and Appendix C: CE conformity . – Removed Electrical schematics
8-Mar-2021	4	Updated: – Figure 2: Hardware block diagram – Section 8: STM32 Nucleo-64 board information

IMPORTANT NOTICE – PLEASE READ CAREFULLY

STMicroelectronics NV and its subsidiaries (“ST”) reserve the right to make changes, corrections, enhancements, modifications, and improvements to ST products and/or to this document at any time without notice. Purchasers should obtain the latest relevant information on ST products before placing orders. ST products are sold pursuant to ST’s terms and conditions of sale in place at the time of order acknowledgement.

Purchasers are solely responsible for the choice, selection, and use of ST products and ST assumes no liability for application assistance or the design of Purchasers’ products.

No license, express or implied, to any intellectual property right is granted by ST herein.

Resale of ST products with provisions different from the information set forth herein shall void any warranty granted by ST for such product.

ST and the ST logo are trademarks of ST. For additional information about ST trademarks, please refer to www.st.com/trademarks. All other product or service names are the property of their respective owners.

Information in this document supersedes and replaces information previously supplied in any prior versions of this document.

© 2021 STMicroelectronics – All rights reserved

Mouser Electronics

Authorized Distributor

Click to View Pricing, Inventory, Delivery & Lifecycle Information:

[STMicroelectronics:](#)

[NUCLEO-G0B1RE](#)