



Features

- Debounce time: 0.3ms to 6s
- RC oscillator determines switching characteristics
- Relay driver with Z-diode
- Debounced input for toggle switch
- Three debounced inputs: ON, OFF and TOGGLE
- Load-dump protection
- RF interference protection
- Protection according to ISO/TR7637-1 (VDE 0839)

Description

The bipolar integrated circuit Atmel® U6032B is designed as a toggle switch. The device, which has a defined power-on status, can be used to control electrical loads, for example, fog lamps, high/low beam or heated windows for automotive applications.

Figure 1. Block Diagram with External Circuit

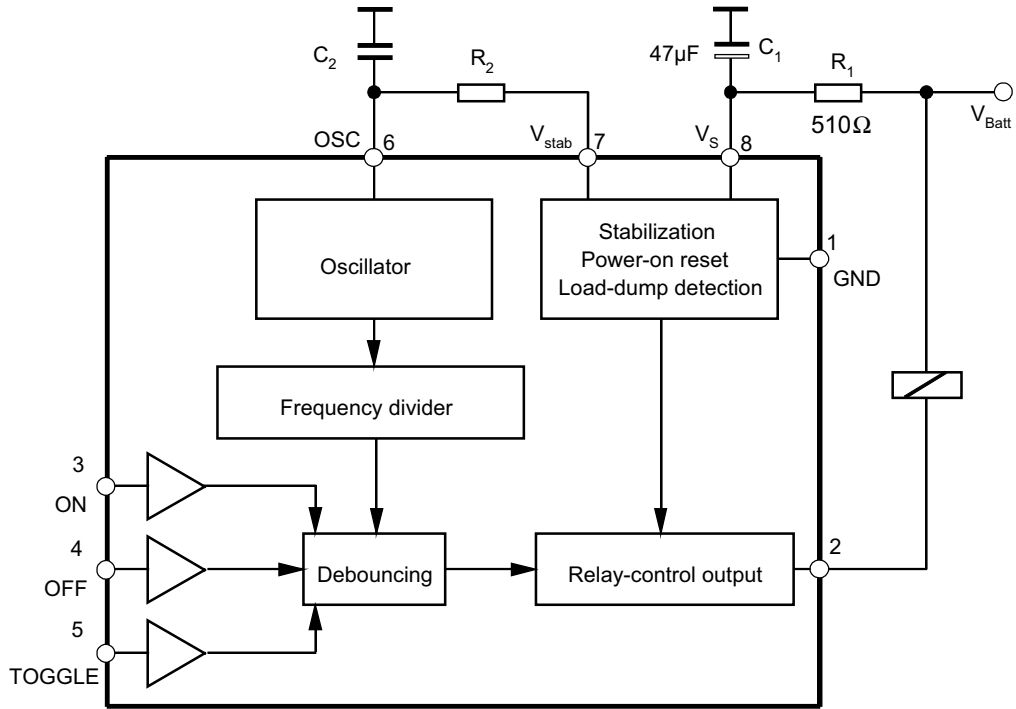

1. Pin Configuration

Figure 1-1. Pinning DIP8

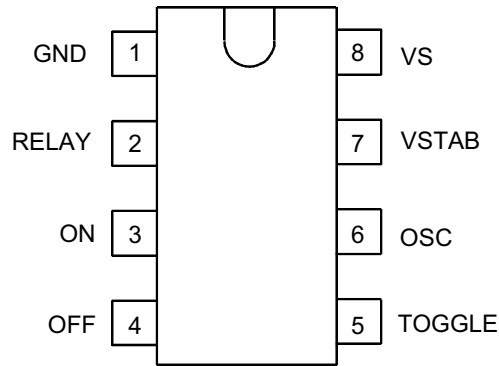

Table 1-1. Pin Description

Pin	Symbol	Function
1	GND	Reference point, ground
2	RELAY	Relay control output
3	ON	Switch-on input
4	OFF	Switch-off input
5	TOGGLE	Toggle input
6	OSC	RC oscillator input
7	VSTAB	Stabilized voltage
8	VS	Supply voltage

2. Functional Description

2.1 Power Supply, Pin 8

To achieve interference protection and surge immunity, the supply voltage (pin 8) must be provided with an RC circuit as shown in Figure 2-1. The dropping resistor, R_1 , limits the current in case of overvoltage, whereas C_1 smooths the supply voltage at pin 8.

Recommended values are: $R_1 = 510\Omega$, $C_1 = 47\mu\text{F}$.

An integrated Z-diode (14V) protects the supply voltage, V_S , thus enabling stable operation in a supply-voltage range of 6V to 16V, supplied by V_{Batt} .

It is possible to operate the integrated circuit with a 5V supply, but it should be assured that there are no interference voltages. In this case, pin 7 is connected to pin 8 as shown in Figure 2-2 on page 4, and the R_1C_1 circuit is omitted.

Figure 2-1. Basic Circuit for 12-V Supply and Oscillator

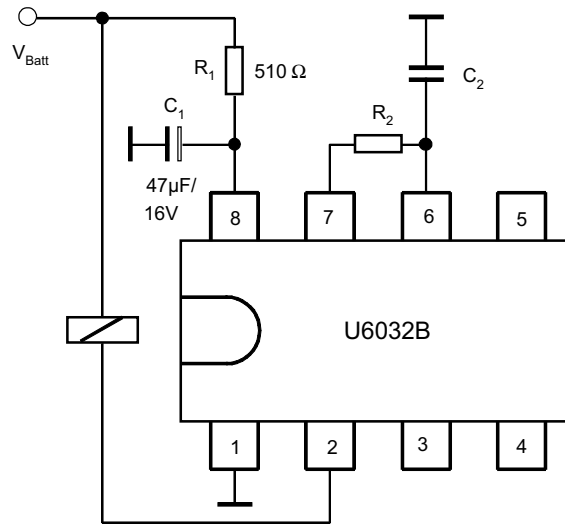
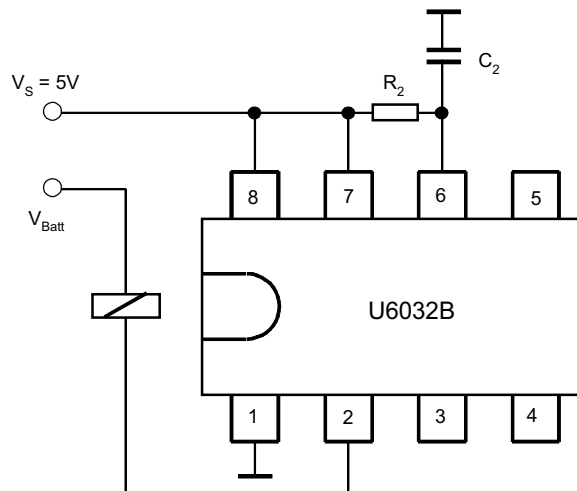

Figure 2-2. Basic Circuit for $V_S = 5\text{V}$



2.2 Oscillator, Pin 6

The oscillator frequency, f , is determined mainly by the R_2C_2 circuit. The resistance, R_2 , determines the charge time, and the integrated resistance ($2k\Omega$) is responsible for the discharge time. To ensure the stability of the oscillator frequency, it is recommended that the selected R_2 value is remarkably greater than the internal resistance ($2k\Omega$), as the temperature response and the tolerances of the integrated resistance are considerably greater than the external resistance value.

The oscillator frequency, f , is calculated as follows:

$$f = \frac{1}{t_1 + t_2}$$

where

$$t_1 = \text{charge time} = \alpha_1 \times R_2 \times C_2$$

$$t_2 = \text{discharge time} = \alpha_2 \times 2k\Omega \times C_2$$

α_1 and α_2 are constants, e.g.:

$$\alpha_1 = 0.833 \text{ and } \alpha_2 = 1.551 \text{ when } C_2 = 470\text{pF to } 10\text{nF}$$

$$\alpha_1 = 0.746 \text{ and } \alpha_2 = 1.284 \text{ when } C_2 = 10\text{nF to } 4700\text{nF}$$

The debounce time, t_3 , depends on the oscillator frequency, f , as follows:

$$t_3 = 6 \times \frac{1}{f}$$

Table 5-1 on page 8 shows the relationship between t_3 , C_2 , R_2 and frequencies from 1Hz to 20kHz.

2.3 Relay-control Output

The relay-control output is an open-collector Darlington circuit with an integrated 23-V Z-diode for limiting the inductive cut-off pulse of the relay coil. The maximum static collector current must not exceed 300mA and the saturation voltage is typically 1.1V at 200 mA.

2.4 Interference Voltages and Load Dump

The IC supply is protected by R_1 , C_1 , and an integrated Z-diode, while the inputs are protected by a series resistor, integrated Z-diode and RF capacitor (refer to [Figure 2-4 on page 6](#)).

The relay-control output is protected by the integrated 23V Z-diode in case of short interference peaks. It is switched to conductive condition for a battery voltage greater than 40V in case of load dump. The output transistor is dimensioned so that it can withstand the generated current.

2.5 Power-on Reset

When the operating voltage is switched on, an internal power-on reset pulse (POR) is generated which sets the logic of the circuits to a defined initial condition. The relay output is disabled.

2.6 Relay-control Output Behavior, Pin 2

The time functions (relay output) can be started or interrupted by the three inputs ON, OFF or TOGGLE (pins 3, 4 and 5, input circuit of these pins see [Figure 2-4 on page 6](#)).

The relay becomes active if the time function is triggered, and the relay contact is interrupted after the elapse of the delay time, t_d . There are two input possibilities.

2.7 Toggle Input, Pin 5

When the push-button (TOGGLE) switch, S_1 , is pressed for the first time, the relay becomes active after the debounce time, t_3 , i.e., the relay output, pin 2, is active.

Repeated operation of S_1 causes the interruption of the relay contact, thus disabling the relay. Each operation of the toggle switch, S_1 , changes (alters) the condition of the relay output when the debounce time, t_3 , is exceeded, i.e., the TOGGLE function.

If the relay output is not disabled by pressing the switch S_1 , the output stays active.

Figure 2-3. TOGGLE Function

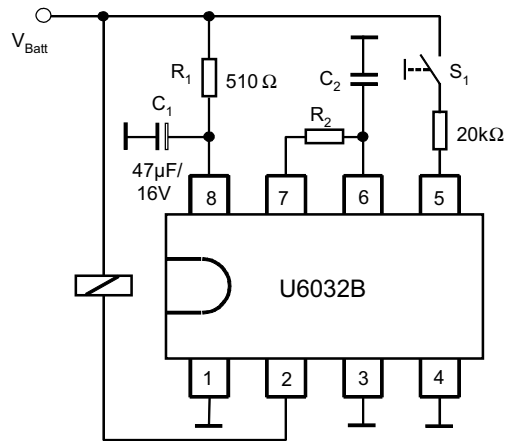

2.8 ON, OFF Inputs, Pins 3 and 4

To avoid simultaneous operation of both inputs, pin 3 (ON) and pin 4 (OFF), the use of a two-way contact with centre-off position with spring returns (also known as rocker-actuated switch) is recommended.

Pressing the push-button switch (pin 3 ON) leads to an activation of the relay after the debounce time, t_3 , has elapsed whereas the switching of pin 4 switch correspondingly leads to the de-energization of the relay. If the relay is not de-energized by the push-button switch, the output remains active.

Combined operation “TOGGLE” and “ON/OFF” is not possible due to the fact that there is only one debouncing circuit. Debouncing is possible in both modes, i.e., whenever S_1 is ON or OFF.

Figure 2-4 shows the input circuit of Atmel® U6032B. It has an integrated pull-down resistor ($20k\Omega$), RF capacitor ($15pF$) and Z-diode ($7V$). It reacts to voltages greater than $2V$. The external protective resistor has a value of $20k\Omega$ and the push-button switch, S , is connected to the battery as shown in the diagram.

The contact current, I , is calculated as follows:

$$I = \frac{V_{\text{Batt}} - V_Z}{R(= 20k\Omega)} \text{ where } V_{\text{Batt}} = 12V, V_Z = 7V$$

$$I = \frac{(12 - 7)V}{20k\Omega} \approx 0.25mA$$

It can be increased by connecting a $5.6k\Omega$ resistor from the push-button switch to ground as shown in Figure 2-6 on page 7.

Figure 2-4. Input Circuit

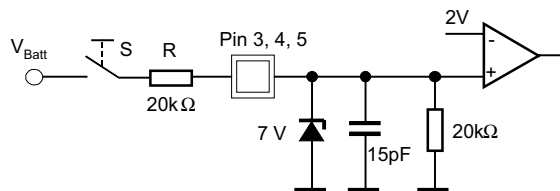

Figure 2-5. ON/OFF Function

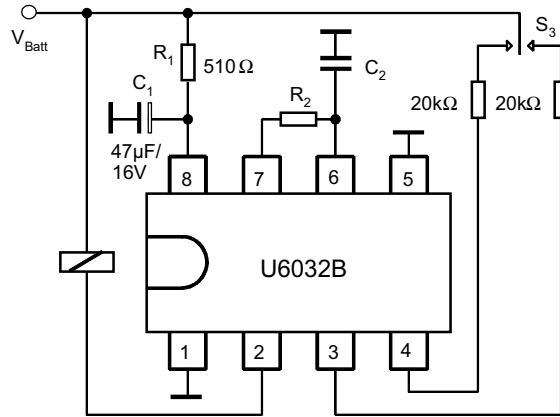
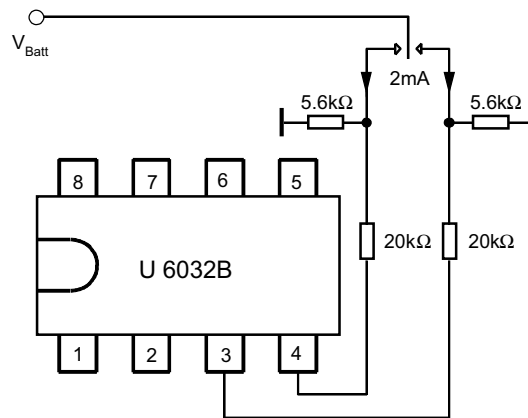

Figure 2-6. Increasing the Contact Current by Parallel Resistors



3. Absolute Maximum Ratings

Stresses beyond those listed under “Absolute Maximum Ratings” may cause permanent damage to the device. This is a stress rating only and functional operation of the device at these or any other conditions beyond those indicated in the operational sections of this specification is not implied. Exposure to absolute maximum rating conditions for extended periods may affect device reliability.

Parameters	Symbol	Value	Unit
Operating voltage, static, 5 minutes	V_{Batt}	24	V
Ambient temperature range	T_{amb}	-40 to +125	°C
Storage temperature range	T_{stg}	-55 to +125	°C
Junction temperature	T_j	150	°C

4. Thermal Resistance

Parameters	Symbol	Value	Unit
Junction ambient DIP8	T_{thJA}	110	K/W

5. Electrical Characteristics

$V_{Batt} = 13.5\text{ V}$, $T_{amb} = 25^\circ\text{C}$, reference point ground, [Figure 1 on page 2](#), unless otherwise specified

Parameters	Test Conditions	Pin	Symbol	Min.	Typ.	Max.	Unit
Operating voltage	$R_1 \geq 510\Omega$ $t < 5\text{min}$ $t < 60\text{min}$		V_{Batt}	6		16 24 18	V
5 V supply	Without R_1 , C_1	7, 8	V_8, V_7	4.3		6.0	V
Stabilized voltage	$V_{Batt} = 12\text{V}$	7	V_7	5.0	5.2	5.4	V
Undervoltage threshold	Power-on reset		V_S	3.0		4.2	V
Supply current	All push buttons open	8	I_S		1.3	2.0	mA
Internal Z-diode	$I_8 = 10\text{mA}$	8	V_Z	13.5	14	16	V
Relay Control Output		2					
Saturation voltage	$I_2 = 200\text{mA}$ $I_2 = 300\text{mA}$		V_2		1.2	1.5	V
Leakage current	$V_2 = 14\text{V}$		I_{lkg}		2	100	μA
Output current			I_2			300	mA
Output Pulse Current							
Load-dump pulse	$t \leq 300\text{ms}$		I_2			1.5	A
Internal Z-diode	$I_2 = 10\text{mA}$		V_Z	20	22	24	V
Oscillator Input	$f = 0.001$ to 40kHz, see Table 5-1	6					
Internal discharge resistance	$V_6 = 5\text{V}$		R_6	1.6	2.0	2.4	$\text{k}\Omega$
Switching thresholds	Lower Upper		V_{6L} V_{6H}	0.9 2.8	1.1 3.1	1.4 3.5	V
Input current	$V_6 = 0\text{V}$		$-I_6$			1	μA
Switching Times							
Debounce time			t_3	5		7	Cycles
Inputs ON, OFF, TOGGLE		3, 4, 5					
Switching threshold voltage			$V_{3,4,5}$	1.6	2.0	2.4	V
Internal Z-diode	$I_{3,4,5} = 10\text{mA}$		$V_{3,4,5}$	6.5	7.1	8.0	V
Pull-down resistance	$V_{3,4,5} = 5\text{V}$		$R_{3,4,5}$	13	20	50	$\text{k}\Omega$

Table 5-1. Values for C_2 and R_2 for a Given Oscillator Frequency and Debounce Time

Frequency f (Hz)	Debounce Time t_3 (ms)	C_2 (nF)	R_2 ($\text{k}\Omega$)
1	6000	4700	280
2	3000	1000	650
3	2000	1000	440
4	1500	1000	330
5	1200	1000	260
6	1000	1000	220
7	857	1000	190
8	750	1000	160
9	667	1000	140
10	600	1000	130

Table 5-1. Values for C₂ and R₂ for a Given Oscillator Frequency and Debounce Time (Continued)

Frequency f (Hz)	Debounce Time t ₃ (ms)	C ₂ (nF)	R ₂ (kΩ)
20	300	100	650
30	200	100	440
40	150	100	330
50	120	100	260
60	100	100	220
70	86	100	190
80	75	100	160
90	67	100	140
100	60	100	130
200	30	10	600
300	20	10	400
400	15	10	300
500	12	10	240
600	10	10	200
700	9.00	10	170
800	8.00	10	150
900	7.00	10	130
1000	6.00	10	120
2000	3.00	1	600
3000	2.00	1	400
4000	1.50	1	300
5000	1.20	1	240
6000	1.00	1	200
7000	0.86	1	170
8000	0.75	1	150
9000	0.67	1	130
10000	0.60	1	120
11000	0.55	1	110
12000	0.50	1	99
13000	0.46	1	91
14000	0.43	1	85
15000	0.40	1	79
16000	0.38	1	74
17000	0.35	1	70
18000	0.33	1	66
19000	0.32	1	62
20000	0.30	1	59

6. Ordering Information

Extended Type Number	Package	Remarks
U6032B-MY	DIP8	Pb-free

7. Package Information

Figure 7-1. DIP8

Package: DIP8
Dimensions in mm

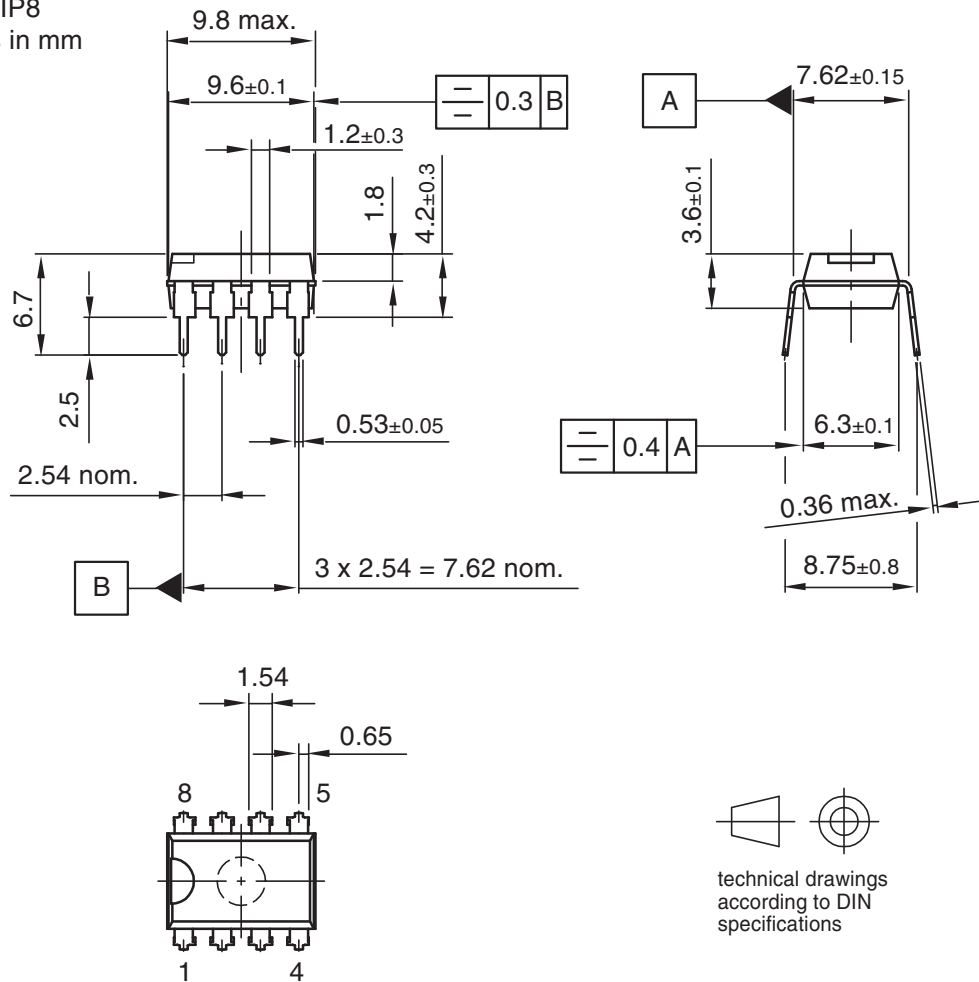

Drawing-No.: 6.543-5040.01-4

Issue: 1; 16.01.02

8. Revision History

Please note that the following page numbers referred to in this section refer to the specific revision mentioned, not to this document.

Revision No.	History
4771C-AUTO-06/12	<ul style="list-style-type: none">• Section 4 “Thermal Resistance” on page 7 changed• Section 7 “Ordering Information” on page 10 changed• Section 8 “Package Information” on page 10 changed
4771B-AUTO-11/05	<ul style="list-style-type: none">• First page: Pb-free logo added• Page 10: Ordering Information changed



Enabling Unlimited Possibilities™

Atmel Corporation

2325 Orchard Parkway
San Jose, CA 95131
USA

Tel: (+1) (408) 441-0311

Fax: (+1) (408) 487-2600

www.atmel.com

Atmel Asia Limited

Unit 01-5 & 16, 19F
BEA Tower, Millennium City 5
418 Kwun Tong Roa
Kwun Tong, Kowloon

HONG KONG

Tel: (+852) 2245-6100

Fax: (+852) 2722-1369

Atmel Munich GmbH

Business Campus
Parkring 4
D-85748 Garching b. Munich
GERMANY

Tel: (+49) 89-31970-0

Fax: (+49) 89-3194621

Atmel Japan G.K.

16F Shin-Osaki Kangyo Building
1-6-4 Osaki
Shinagawa-ku, Tokyo 141-0032
JAPAN

Tel: (+81) (3) 6417-0300

Fax: (+81) (3) 6417-0370

© 2012 Atmel Corporation. All rights reserved. / Rev.: 4771C-AUTO-06/12

Atmel®, Atmel logo and combinations thereof, Enabling Unlimited Possibilities®, and others are registered trademarks or trademarks of Atmel Corporation or its subsidiaries. Other terms and product names may be trademarks of others.

Disclaimer: The information in this document is provided in connection with Atmel products. No license, express or implied, by estoppel or otherwise, to any intellectual property right is granted by this document or in connection with the sale of Atmel products. EXCEPT AS SET FORTH IN THE ATMEL TERMS AND CONDITIONS OF SALES LOCATED ON THE ATMEL WEBSITE, ATMEL ASSUMES NO LIABILITY WHATSOEVER AND DISCLAIMS ANY EXPRESS, IMPLIED OR STATUTORY WARRANTY RELATING TO ITS PRODUCTS INCLUDING, BUT NOT LIMITED TO, THE IMPLIED WARRANTY OF MERCHANTABILITY, FITNESS FOR A PARTICULAR PURPOSE, OR NON-INFRINGEMENT. IN NO EVENT SHALL ATMEL BE LIABLE FOR ANY DIRECT, INDIRECT, CONSEQUENTIAL, PUNITIVE, SPECIAL OR INCIDENTAL DAMAGES (INCLUDING, WITHOUT LIMITATION, DAMAGES FOR LOSS AND PROFITS, BUSINESS INTERRUPTION, OR LOSS OF INFORMATION) ARISING OUT OF THE USE OR INABILITY TO USE THIS DOCUMENT, EVEN IF ATMEL HAS BEEN ADVISED OF THE POSSIBILITY OF SUCH DAMAGES. Atmel makes no representations or warranties with respect to the accuracy or completeness of the contents of this document and reserves the right to make changes to specifications and products descriptions at any time without notice. Atmel does not make any commitment to update the information contained herein. Unless specifically provided otherwise, Atmel products are not suitable for, and shall not be used in, automotive applications. Atmel products are not intended, authorized, or warranted for use as components in applications intended to support or sustain life.

Mouser Electronics

Authorized Distributor

Click to View Pricing, Inventory, Delivery & Lifecycle Information:

[Atmel:](#)

[U6032B-MFPG3Y](#) [U6032B-MFPY](#) [U6032B-MY](#)