

Electronic housing - HC-ALU 6-161 PROFILE 100 - 2200902

Please be informed that the data shown in this PDF Document is generated from our Online Catalog. Please find the complete data in the user's documentation. Our General Terms of Use for Downloads are valid (<http://phoenixcontact.com/download>)



Profile housing, Lower part, profile width (internal): 161 mm, length: 100 mm, height: 187 mm, color: aluminum color

Your advantages

- ✔ Item is from the HC-ALU product range
- ✔ Aluminum press-drawn section
- ✔ Available in lengths from 100 mm ... 1000 mm, can be individually cut to any length
- ✔ Available in overall widths 53.5 mm ... 161 mm
- ✔ Degree of protection up to IP65
- ✔ Usable as handheld and wall housing
- ✔ Optional EMC seals available



Key Commercial Data

Packing unit	1 pc
GTIN	 4 046356 715843
GTIN	4046356715843

Technical data

Product properties

Brief article description	Electronic housing
Type	HC-ALU 6-161 PROFILE 100
Order No.	2200902
Housing type	Profile housing
Type	Lower part
Max. IP code to attain	IP65
Mounting type	Wall mounting (with accessories as an option)

Dimensions

Length [1]	100 mm
--------------	--------

Electronic housing - HC-ALU 6-161 PROFILE 100 - 2200902

Technical data

Dimensions

Profile width (external)	187 mm
Profile width (internal)	161 mm
Height	187 mm
Depth [d]	54.6 mm

Material specifications

Material	Aluminum
Color	aluminum color
Surface characteristics	anodized

Ambient conditions

Ambient temperature (operation)	-40 °C ... 85 °C
---------------------------------	------------------

PCB specifications

Number of PCB holders	13
Type of PCB mount	Slot

Packaging specifications

Pieces per package	1
Denomination packing units	Pcs.

Drawings

Electronic housing - HC-ALU 6-161 PROFILE 100 - 2200902

Dimensional drawing

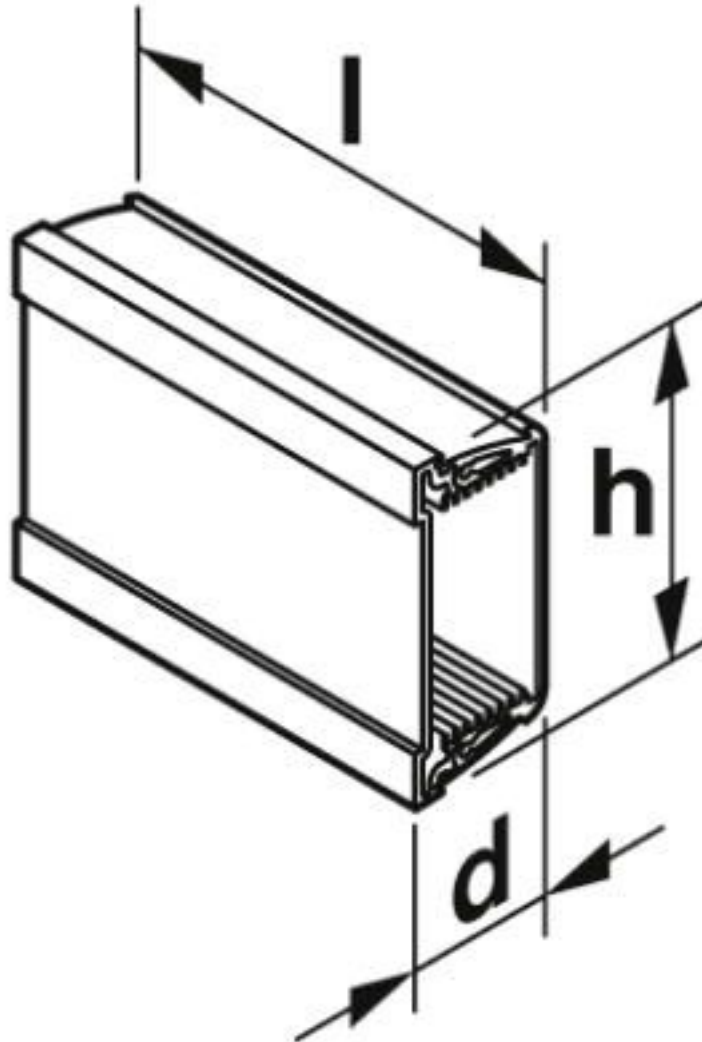

Electronic housing - HC-ALU 6-161 PROFILE 100 - 2200902

Dimensional drawing

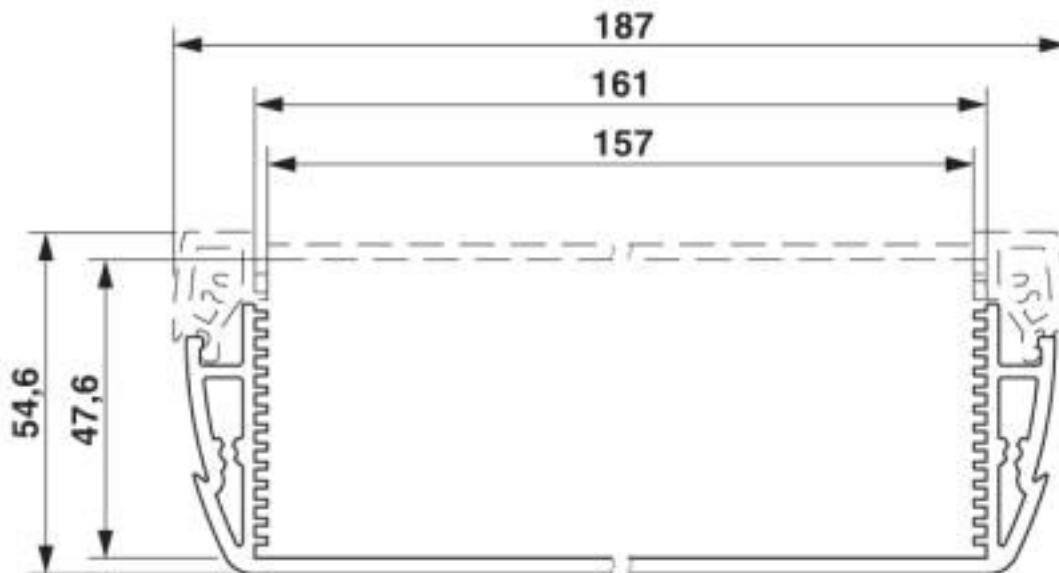

Classifications

eCl@ss

eCl@ss 10.0.1	27182701
eCl@ss 4.0	27180400
eCl@ss 4.1	27180400
eCl@ss 5.0	27180500
eCl@ss 5.1	27180500
eCl@ss 6.0	27182000
eCl@ss 7.0	27182701
eCl@ss 8.0	27182701
eCl@ss 9.0	27182701

ETIM

ETIM 3.0	EC001031
ETIM 4.0	EC000721
ETIM 5.0	EC002779
ETIM 6.0	EC002779
ETIM 7.0	EC002779

UNSPSC

UNSPSC 6.01	31261501
UNSPSC 7.0901	31261501
UNSPSC 11	31261501
UNSPSC 12.01	31261501
UNSPSC 13.2	31261501

Electronic housing - HC-ALU 6-161 PROFILE 100 - 2200902

Classifications

UNSPSC

UNSPSC 18.0	31261501
UNSPSC 19.0	31261501
UNSPSC 20.0	31261501
UNSPSC 21.0	31261501

Accessories

Accessories

Mounting material

Mounting material - HC-ALU 6 DECO 100 GY - 2200914



Decorative strip for HC-ALU panel mounting base

Mounting material - HC-ALU 6 MOUNT 100 GY - 2200911



Mounting foot for panel mounting the HC-ALU panel mounting base

Seal

Seal - HC-ALU 6-161 SEAL EMC - 2200910



EMC seal for HC-ALU panel mounting base

Tool set

Tool set - SF-M SET - 1212543



Bit screwdriver set with quick-action chuck, 89 mm long slotted/crosshead (PZ and PH)/hex/Torx® bits, 17-part, in folding belt pouch, contents: PH 1,2,3 x 89; PZ 1,2,3 x 89; SL 1.5 x 5.5 x 89; TX 10-30 x 89; SW 3,4,5,6 x 89

Electronic housing - HC-ALU 6-161 PROFILE 100 - 2200902

Accessories

Tool set - SF-TXH SET - 1212538



Screwdriver set, Torx[®] with drill bit, 6-part, incl. rack, contents: TX 8 x 60; TX 10 x 80; TX 15 x 80; TX 20 x 100; TX 25 x 100; TX 30 x 115

Necessary add-on products

End cover - HC-ALU 6-161 COVER GY - 2200906



Profile housing, Side part, width: 190.4 mm

Phoenix Contact 2020 © - all rights reserved
<http://www.phoenixcontact.com>

PHOENIX CONTACT GmbH & Co. KG
Flachsmarktstr. 8
32825 Blomberg
Germany
Tel. +49 5235 300
Fax +49 5235 3 41200
<http://www.phoenixcontact.com>

Mouser Electronics

Authorized Distributor

Click to View Pricing, Inventory, Delivery & Lifecycle Information:

[Phoenix Contact:](#)

[2200902](#)