

ACCESSORIES

SP RELAYS TERMINAL SOCKETS



TYPES

Product name	Part No.
SP2 Terminal socket	SP2-SF
SP4 Terminal socket	SP4-SF

DIMENSIONS (mm inch)

The CAD data of the products with a **CAD Data** mark can be downloaded from: <http://industrial.panasonic.com/ac/e/>

SP2 Terminal socket

CAD Data

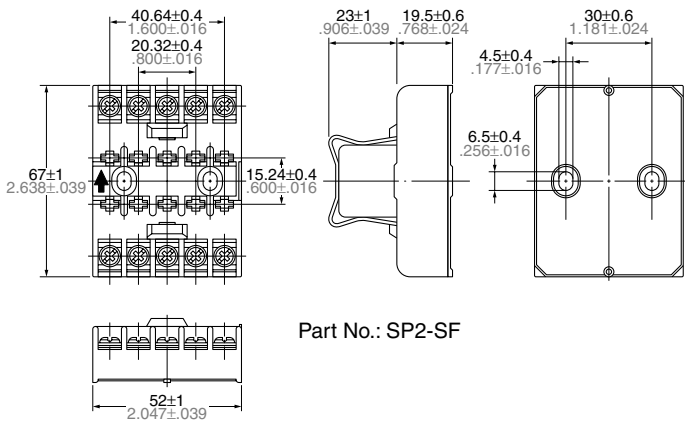

SP4 Terminal socket

CAD Data

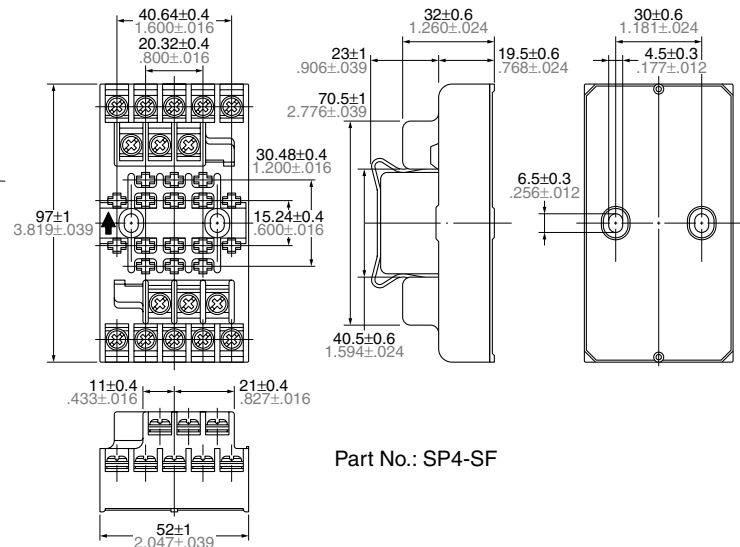

Note: Terminal number marking is on the socket body. Please refer together with the SP relay schematic.

General tolerance: $\pm 0.5 \pm 0.20$

Mounting hole diagram

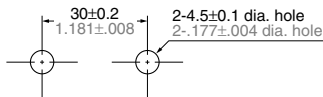

Notes:

- (1) Mounting screws and the fastening bracket are included in the package.
- (2) Mount the relay with the proper mounting direction — i.e. with the direction of the **M** mark on top of the relay case matching the direction of the **M** mark on the terminal block. (The **↑** direction of the terminal block is the upward direction of the relay.)

Fastening bracket mounting and removal

1. Mounting

Insert the A part of the fastening bracket into the mounting groove of the terminal block, and then fit the B part into groove, while pressing with the tip of a minus screwdriver.

2. Removal

Slide the B part of the fastening bracket from the groove in the terminal block, while pressing with the tip of a minus screwdriver. While the bracket is in this position, keep pressing the C part of the bracket to the relay side with your finger, and lift up to the left side and remove from the groove, as in the diagram at right.

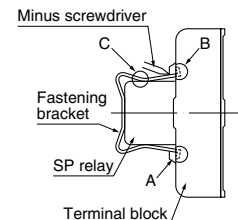

ACCESSORIES

SP RELAYS MOUNTING BOARD

TYPES

Product name	Part No.
Mounting board	SP-MA

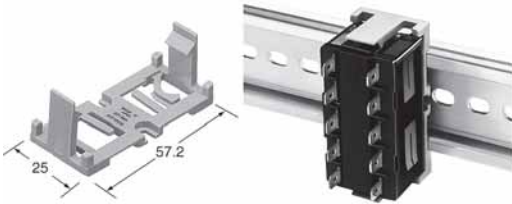

Direct chassis mounting possible, and applicable to DIN rail.

DIMENSIONS (mm inch)

The CAD data of the products with a **CAD Data** mark can be downloaded from: <http://industrial.panasonic.com/ac/e/>

CAD Data

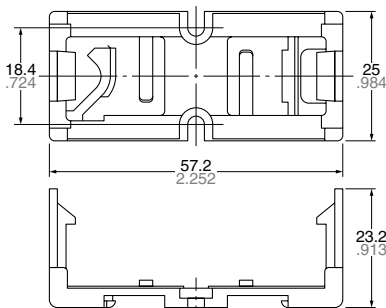

Mounting hole diagram

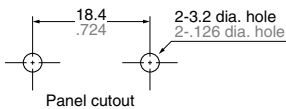

Panel cutout

Tolerance: $\pm 0.1 \pm 0.004$

Use method

- Both the SP relay 2 Form C and 4 Form C can be mounted to the mounting slats.
- Use the mounting slats either by attaching them directly to the chassis, or by mounting with a DIN rail.
 - When attaching directly to chassis
 - Use two M3 screws.
 - For the mounting pitch, refer to the specification diagram.
 - When mounting on a DIN rail
 - Use a 35mm 1.378inch wide DIN rail (DIN46277).
 - The mounting method should be as indicated in the diagram at right.

Method for mounting on DIN rail

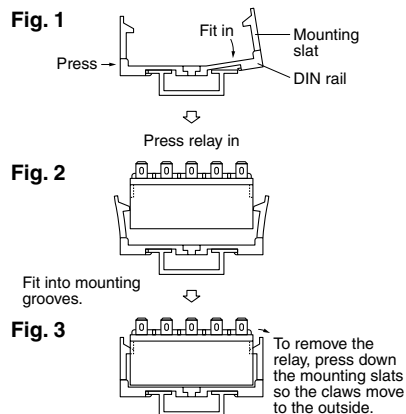

- First fit the arc shaped claw of the mounting slat into the DIN rail.
- Press on the side as shown in the diagram below.
- Fit in the claw part on the opposite side.

Precautions for use

When mounting to a DIN rail, use a commercially available fastening bracket if there is a need to stop sliding of the mounting slat in the rail direction.

Mouser Electronics

Authorized Distributor

Click to View Pricing, Inventory, Delivery & Lifecycle Information:

[Panasonic:](#)

[SP2-SF](#) [SP4-SF](#)