

SUBMINIATURE, LONG STROKE SEALED SWITCHES

TURQUOISE STROKE MINI SWITCHES

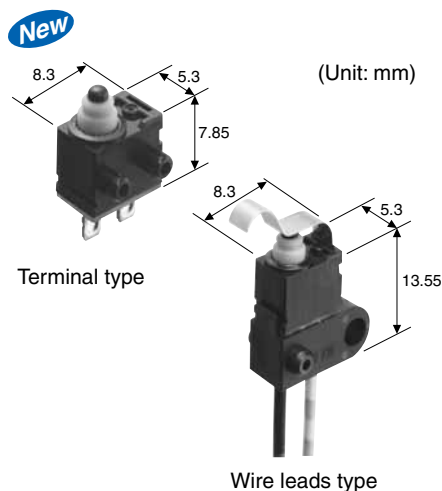

RoHS compliant

FEATURES

- Miniaturization achieved with changing from 1 Form C to 1 Form A or 1 Form B contacts. (For the terminal type, volume has been cut 45% compared to our previous product.)
- Lever installation possible while being miniature. Operation possible in various moving parts such as metal cams.
- Contact pressure does not depend on the operation stroke.
- High contact reliability to support low level switching loads.
- Highly effective sealing for resistance against adverse environments. (IP67)
- Silent operation with sliding contact.

TYPICAL APPLICATIONS

- Automobiles (detection of door opening and closing, shift lever position, etc.)
- Household appliances (vacuum cleaners, air conditioners, washing machines, etc.)

ORDERING INFORMATION

ASQM1



Mounting

- 1: Without boss type (wire leads type only)
- 6: Right 2 boss type (terminal type only)
- 7: Left 2 boss type (terminal type only)

Terminal

- 4: Terminal type (Solder terminal)
- 6: Wire leads type

Contact form

- 2: Normally Closed type (NC)
- 3: Normally Open type (NO)

Actuator

- 0: Pin plunger
- 8: Simulated roller lever

Note: Not every combination is available. Please refer to the following table, "PRODUCT TYPES".

PRODUCT TYPES

1. Terminal type (solder terminal)

Carton: 1,000 pcs.

Actuator	Right 2 boss type		Left 2 boss type	
	NC type	NO type	NC type	NO type
Pin plunger	ASQM16420	ASQM16430	ASQM17420	ASQM17430
Simulated roller lever	ASQM16428	ASQM16438	ASQM17428	ASQM17438

2. Wire leads type

Carton: 240 pcs.

Actuator	NC type	NO type
Pin plunger	ASQM11620	ASQM11630
Simulated roller lever	ASQM11628	ASQM11638

Turquoise Stroke mini Switch

RATING

1. Rating

1 mA, 5 V DC to 50 mA, 16 V DC

2. Operation environment and conditions

Item	Specifications
Ambient and storage temperature	-40°C to +85°C (no freezing and condensing)
Allowable operating speed	30 to 500 mm/sec.
Max. operating cycle rate	120 cpm

Note: When switching at low and high speeds or under vibration, or in high-temperature, high-humidity environments, life and performance may be reduced significantly depending on the load capacity. Please consult us.

3. Electrical characteristics

Item	Specifications
Withstand voltage (Initial)	Between non-continuous terminals: 500 Vrms, Between each terminal and other exposed metal parts: 1,500 Vrms, Between each terminal and ground: 1,500 Vrms (at detection current of 1 mA)
Insulation resistance (Initial)	Min. 100 MΩ (at 500 V DC insulation resistance meter) (Locations measured same as withstand voltage.)
Contact resistance (Initial)	Max. 500 mΩ (By voltage drop 50 mA 6 to 8 V DC)

4. Characteristics

Item	Specifications
Electrical switching life	5 V DC 1 mA (resistive load) Min. 3×10^5
	12 V DC 50 mA (resistive load) Min. 2×10^5
	16 V DC 50 mA (resistive load) Min. 1.5×10^5
Vibration resistance (malfunction vibration resistance)	Single amplitude: 0.75 mm Amplitude of vibration: 10 to 55 Hz (4 minutes cycle) Direction and time: 30 minutes each in X, Y and Z directions
	Amplitude of vibration: 5 to 200 Hz (10 minutes cycle) Acceleration: 43.1 m/s ² Direction and time: 30 minutes each in X, Y and Z directions
Shock resistance (malfunction shock resistance)	Shock value: 980 m/s ² Direction and time: 5 times each in X, Y and Z directions
Terminal strength	6 N min. (each direction) *Terminal deformation possible.
Heat resistance	85°C 500 hours
Cold resistance	-40°C 500 hours
Humidity resistance	40°C 95% RH 500 hours
Water resistance	IP67 (Wire leads type)

Notes: As long as there are no particular designations, the following conditions apply to the test environment.

- Ambient temperature: 5 to 35°C
- Relative humidity: 25 to 85% RH
- Air pressure: 86 to 106 kPa

5. Protective structure

- 1) JIS C0920 (water-resistance experiments for electrical machines and protection rating against incursion of solid substances): Immersion protected (Note 1)
- 2) IEC 60529 (rating for outer shell protection): IP67 (Immersion protected) (Note 1)
except metal terminal part (See below drawing)

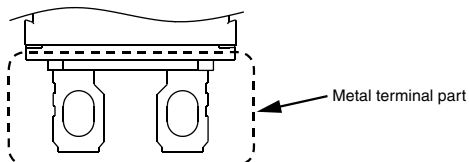

- 3) JIS D0203 (method for testing moisture resistance and water resistance in automotive components): Equivalent of D2 (Note 2)

Note 1) A concrete testing method is to check for any adverse effect on the structure after leaving it submerged for 30 minutes under 1 m of water (with temperature difference between water and switch no larger than 5°C).

Note 2) A concrete testing method is to check for any adverse effect on the structure after leaving it submerged for 10 minutes under 10 cm water (with temperature difference between water and switch no larger than 30°C).

6. Operating characteristics

Characteristics		Pin plunge	Simulated roller lever
Operating Force (O.F.) max.		1.2N	1.5N
Total Travel Force (T.F.) max. (Reference value)		(3.0N)	(2.8N)
Free Position (F.P.) max.	Terminal type	7.7mm	13.4mm
	Wire leads type	14.45mm	20.15mm
Operating Position (O.P.)	Terminal type	Initial: 7.1±0.25mm After test: 7.1±0.3mm	Initial: 10.75±0.6mm After test: 10.75±0.7mm
	Wire leads type	Initial: 13.75±0.35mm After test: 13.75±0.4mm	Initial: 17.4±0.7mm After test: 17.4±0.8mm
Release Position (R.P.)	Terminal type	Initial: 7.15±0.3mm After test: 7.15±0.35mm	Initial: 11.05±0.7mm After test: 11.05±0.8mm
	Wire leads type	Initial: 13.8±0.4mm After test: 13.8±0.45mm	Initial: 17.7±0.8mm After test: 17.7±0.9mm
Over Travel (O.T.) min.	Terminal type	Initial: 1.75mm After test: 1.70mm	Initial: 2.25mm After test: 2.15mm
	Wire leads type	Initial: 1.65mm After test: 1.60mm	Initial: 2.15mm After test: 2.05mm
Total Travel Position (T.T.P.) (Reference value)	Terminal type	(5.1mm)	(7.9mm)
	Wire leads type	(11.75mm)	(14.55mm)

Note: The above indicates the characteristics when operating the actuator from the vertical direction.

DATA

Applicable current range (Reference)

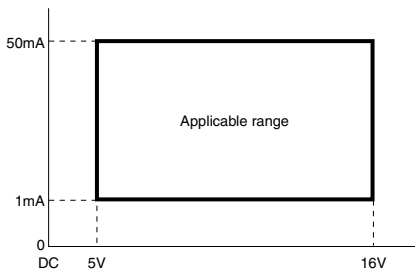

DIMENSIONS

The CAD data of the products with a **CAD Data** mark can be downloaded from: <http://industrial.panasonic.com/ac/e/>

1. Terminal type (Solder terminal), Right 2 boss type, Pin plunger

mm General tolerance: ±0.25

CAD Data

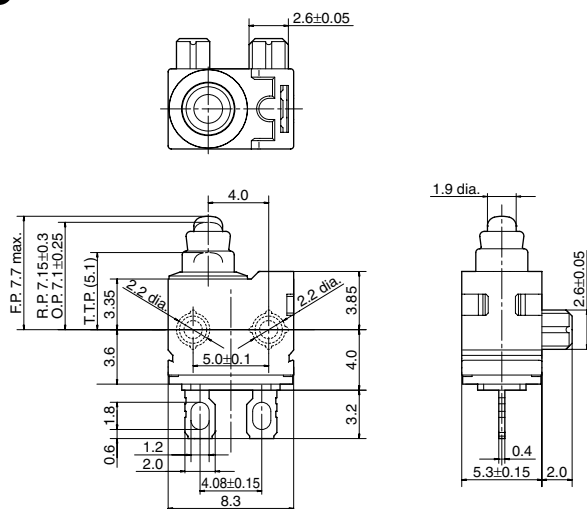

Operating Force (O.F.) max.	1.2N
Total Travel Force (T.F.) max. (Reference value)	(3.0N)
Free Position (F.P.) max.	7.7mm
Operating Position (O.P.)	Initial: 7.1±0.25mm After test: 7.1±0.3mm
Release Position (R.P.)	Initial: 7.15±0.3mm After test: 7.15±0.35mm
Over Travel (O.T.) min.	Initial: 1.75mm After test: 1.70mm
Total Travel Position (T.T.P.) (Reference value)	(5.1mm)

Turquoise Stroke mini Switch

2. Terminal type (Solder terminal), Left 2 boss type, Pin plunger

mm General tolerance: ± 0.25

CAD Data

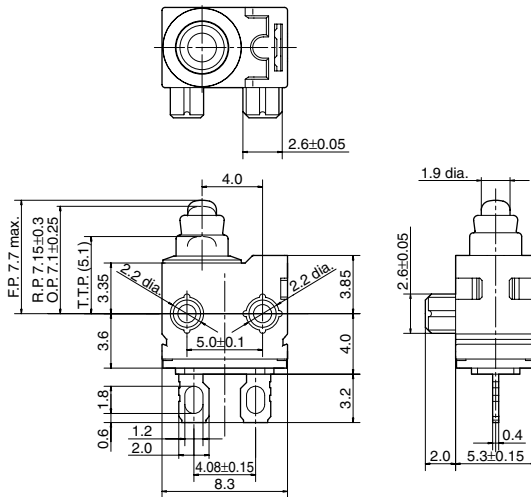

Operating Force (O.F.) max.	1.2N
Total Travel Force (T.F.) max. (Reference value)	(3.0N)
Free Position (F.P.) max.	7.7mm
Operating Position (O.P.)	Initial: 7.1 ± 0.25 mm After test: 7.1 ± 0.3 mm
Release Position (R.P.)	Initial: 7.15 ± 0.3 mm After test: 7.15 ± 0.35 mm
Over Travel (O.T.) min.	Initial: 1.75mm After test: 1.70mm
Total Travel Position (T.T.P.) (Reference value)	(5.1mm)

3. Terminal type (Solder terminal), Right 2 boss type, Simulated roller lever

CAD Data

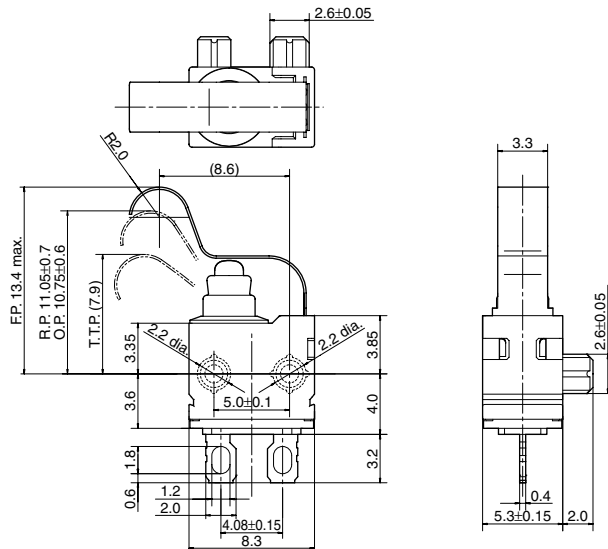

Operating Force (O.F.) max.	1.5N
Total Travel Force (T.F.) max. (Reference value)	(2.8N)
Free Position (F.P.) max.	13.4mm
Operating Position (O.P.)	Initial: 10.75 ± 0.6 mm After test: 10.75 ± 0.7 mm
Release Position (R.P.)	Initial: 11.05 ± 0.7 mm After test: 11.05 ± 0.8 mm
Over Travel (O.T.) min.	Initial: 2.25mm After test: 2.15mm
Total Travel Position (T.T.P.) (Reference value)	(7.9mm)

4. Terminal type (Solder terminal), Left 2 boss type, Simulated roller lever

CAD Data

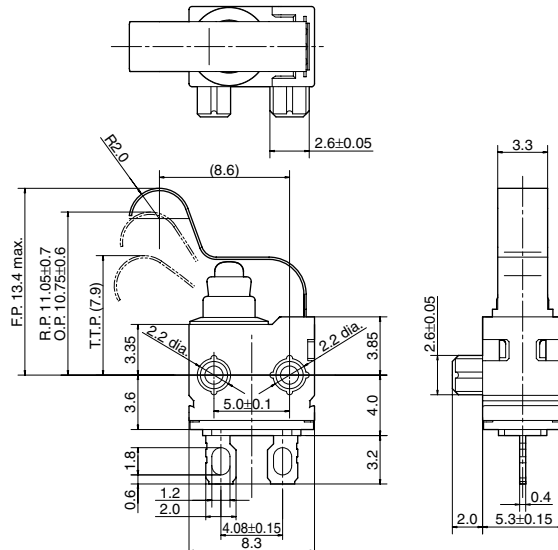

Operating Force (O.F.) max.	1.5N
Total Travel Force (T.F.) max. (Reference value)	(2.8N)
Free Position (F.P.) max.	13.4mm
Operating Position (O.P.)	Initial: 10.75 ± 0.6 mm After test: 10.75 ± 0.7 mm
Release Position (R.P.)	Initial: 11.05 ± 0.7 mm After test: 11.05 ± 0.8 mm
Over Travel (O.T.) min.	Initial: 2.25mm After test: 2.15mm
Total Travel Position (T.T.P.) (Reference value)	(7.9mm)

5. Wire leads type, Pin plunger

mm General tolerance: ±0.25

CAD Data

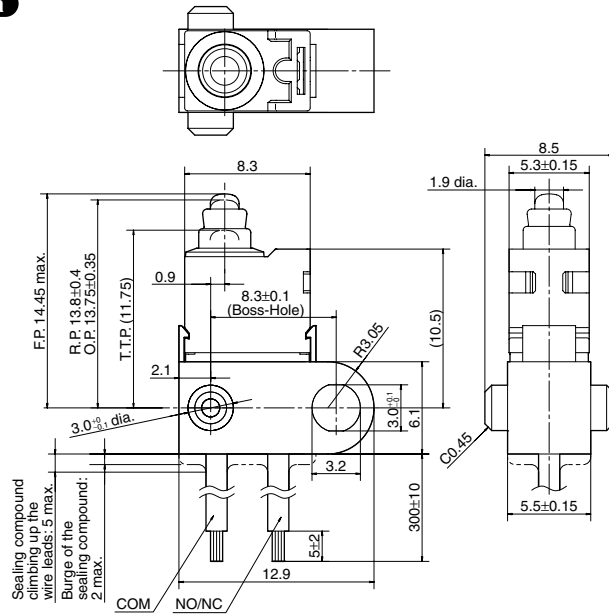

Operating Force (O.F.) max.	1.2N
Total Travel Force (T.F.) max. (Reference value)	(3.0N)
Free Position (F.P.) max.	14.45mm
Operating Position (O.P.)	Initial: 13.75±0.35mm After test: 13.75±0.4mm
Release Position (R.P.)	Initial: 13.8±0.4mm After test: 13.8±0.45mm
Over Travel (O.T.) min.	Initial: 1.65mm After test: 1.60mm
Total Travel Position (T.T.P.) (Reference value)	(11.75mm)

6. Wire leads type, Simulated roller lever

CAD Data

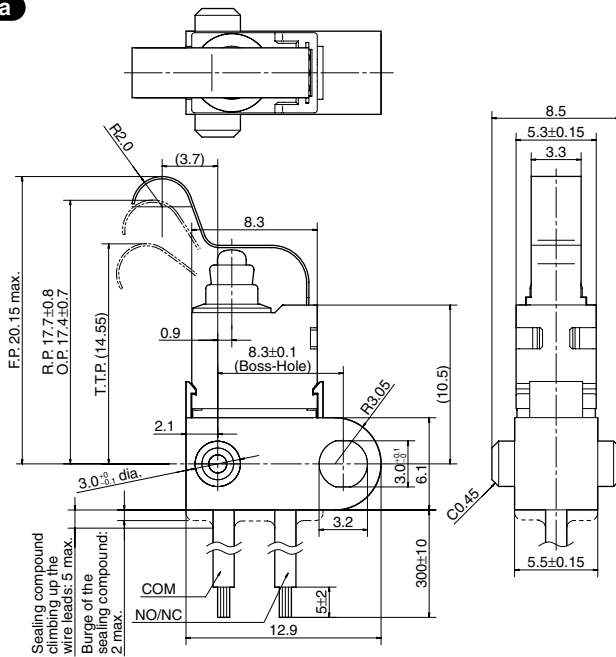

Operating Force (O.F.) max.	1.5N
Total Travel Force (T.F.) max. (Reference value)	(2.8N)
Free Position (F.P.) max.	20.15mm
Operating Position (O.P.)	Initial: 17.4±0.7mm After test: 17.4±0.8mm
Release Position (R.P.)	Initial: 17.7±0.8mm After test: 17.7±0.9mm
Over Travel (O.T.) min.	Initial: 2.15mm After test: 2.05mm
Total Travel Position (T.T.P.) (Reference value)	(14.55mm)

CAUTIONS FOR USE

1. Soldering conditions

- The application of excessive heat upon the switch when soldering can cause degradation of switch operation. Therefore, be sure to keep within the conditions given below.
- Manual soldering: Use soldering irons (max. 350°C, within 3 seconds) capable of temperature adjustment. This is to prevent deterioration due to soldering heat. Care should be taken not to apply force to the terminals during soldering. (More than one second interval is required to apply heat at each terminal.)

2. Mounting

- To secure the wire leads type switch, please use M3 small screws on a flat surface and tighten using a maximum torque of 0.29 N·m. Be sure to verify the quality under actual conditions of use because the switch plastic might be deformed according to that the kind of the screw (size of screw head etc.), the diameter of the washer and the presence of washer. And use of adhesive lock is recommended to prevent loosening of the screws. When using an adhesive, care should be taken not to invade the adhesive into the switches.

- Be sure to maintain adequate insulating clearance between each terminal and ground.
- The positioning of the switch should be such that direct force is not applied to the plunger or actuator in its free position. The operating force to the plunger should only be applied in a perpendicular direction.
- Although it is possible to directly operate the pin plunger type from the lateral direction, please consult us if doing so.
- After mounting please make sure no pulling load will be applied to the switch terminals.

Turquoise Stroke mini Switch

3. Cautions regarding the circuit

- In order to prevent malfunction in set devices caused by bounce and chattering during the ON-OFF switch operation, please verify the validity of the circuit under actual operating conditions and temperature range.
- When switching inductive loads (relays, solenoids, buzzers, etc.), an arc absorbing circuit is recommended to protect the contacts.

4. Please verify under actual conditions.

- Please be sure to conduct quality verification under actual operating conditions in order to increase reliability during actual use.

5. Switch selection

- Please make your selection so that there will be no problems even if the operating characteristics vary up to $\pm 20\%$ from the standard values.

6. Oil-proof and chemical-proof characteristics

- The rubber cap swells when exposed to oil and chemicals. The extent of swelling will vary widely depending on the type and amount of oil and chemicals. Check with the actual oil or chemicals used. In particular, be aware that solvents such as freon, chlorine, and toluene cannot be used.

7. Operation environment

- Although continuous operation of the switch is possible within the range of ambient temperature (humidity), as the humidity range differs depending on the ambient temperature, the humidity range indicated below should be used. Continuous use near the limit of the range should be avoided. This temperature-humidity range does not guarantee permanent performance.

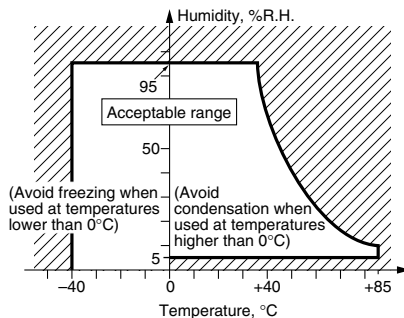

8. Others

- Please remember that this switch cannot be used under water. Also, please be warned that switching and sudden temperature changes with the presence of water droplets can cause seepage into the unit.
- Keep away from environments where silicon based adhesives, oil or grease are present as faulty contacts may result from silicon oxide. Do not use in areas where flammable or explosive gases from gasoline and thinner, etc., may be present.
- When using the lever type, please be careful not to apply unreasonable load from the reverse or lateral directions of operation.
- Do not exceed the total travel position (T.T.P.) and press the actuator. This could cause operation failure. Also, when switching at high speed or under shock even within the operation limit, the working life may decrease. Therefore, please be sure to verify the quality under actual conditions of use.
- Please make considerations so that the switch does not become the stopper for the moving part.
- Please do not constantly apply a tensile load to wire leads when fixing them.

Please contact

Panasonic Corporation

Automation Controls Business Division

■ Head Office: 1048, Kadoma, Kadoma-shi, Osaka 571-8686, Japan

■ Telephone: +81-6-6908-1050 ■ Facsimile: +81-6-6908-5781

industrial.panasonic.com/ac/e/

Panasonic®

© Panasonic Corporation 2013

Mouser Electronics

Authorized Distributor

Click to View Pricing, Inventory, Delivery & Lifecycle Information:

Panasonic:

[ASQM16420](#) [ASQM16428](#) [ASQM17438](#) [ASQM17430](#) [ASQM16438](#) [ASQM16430](#) [ASQM17420](#) [ASQM17428](#)
[ASQM11630](#) [ASQM11638](#) [ASQM11628](#) [ASQM11620](#) [ASQM17420-A](#)