

MPL3115A2

I²C precision pressure sensor with altimetry

Rev. 8 — 12 April 2018

Data sheet: technical data

1 General description

The MPL3115A2 is a compact, piezoresistive, absolute pressure sensor with an I²C digital interface. MPL3115A2 has a wide operating range of 20 kPa to 110 kPa, a range that covers all surface elevations on earth. The MEMS is temperature compensated utilizing an on-chip temperature sensor. The pressure and temperature data is fed into a high resolution ADC to provide fully compensated and digitized outputs for pressure in Pascals and temperature in °C. The compensated pressure output can then be converted to altitude, utilizing the formula stated in [Section 9.1.3 "Pressure/altitude"](#) provided in meters. The internal processing in MPL3115A2 removes compensation and unit conversion load from the system MCU, simplifying system design.

MPL3115A2's advanced ASIC has multiple user programmable modes such as power saving, interrupt and autonomous data acquisition modes, including programmed acquisition cycle timing, and poll-only modes. Typical active supply current is 40 µA per measurement-second for a stable 10 cm output resolution.

2 Features and benefits

- Operating range: 20 kPa to 110 kPa absolute pressure
- Calibrated range: 50 kPa to 110 kPa absolute pressure
- Calibrated temperature output: -40 °C to 85 °C
- I²C digital output interface
- Fully compensated internally
- Precision ADC resulting in 0.1 meter of effective resolution
- Direct reading
 - Pressure: 20-bit measurement (Pascals)
 - 20 to 110 kPa
 - Altitude: 20-bit measurement (meters)
 - -698 to 11,775 m
 - Temperature: 12-bit measurement (°C)
 - -40 °C to 85 °C
- Programmable interrupts
- Autonomous data acquisition
 - Embedded 32-sample FIFO
 - Data logging up to 12 days using the FIFO
 - One-second to nine-hour data acquisition rate
- 1.95 V to 3.6 V supply voltage, internally regulated
- 1.6 V to 3.6 V digital interface supply voltage
- Operating temperature from -40 °C to +85 °C



3 Applications

- High-accuracy altimetry and barometry
- Smartphones, tablets and wearable devices
- GPS applications: dead reckoning, map assist, navigation, enhancement for emergency services
- Weather station equipment

4 Ordering information

Table 1. Ordering information

| Device number | Shipping | Package | Number of ports | | | | Pressure Type | | Digital interface |
|---------------|---------------|--------------|-----------------|--------|------|-------|---------------|----------|-------------------|
| | | | None | Single | Dual | Gauge | Differential | Absolute | |
| MPL3115A2 | Tray | 98ASA002260D | • | — | — | — | — | • | • |
| MPL3115A2R1 | Tape and reel | 98ASA002260D | • | — | — | — | — | • | • |

5 Block diagram

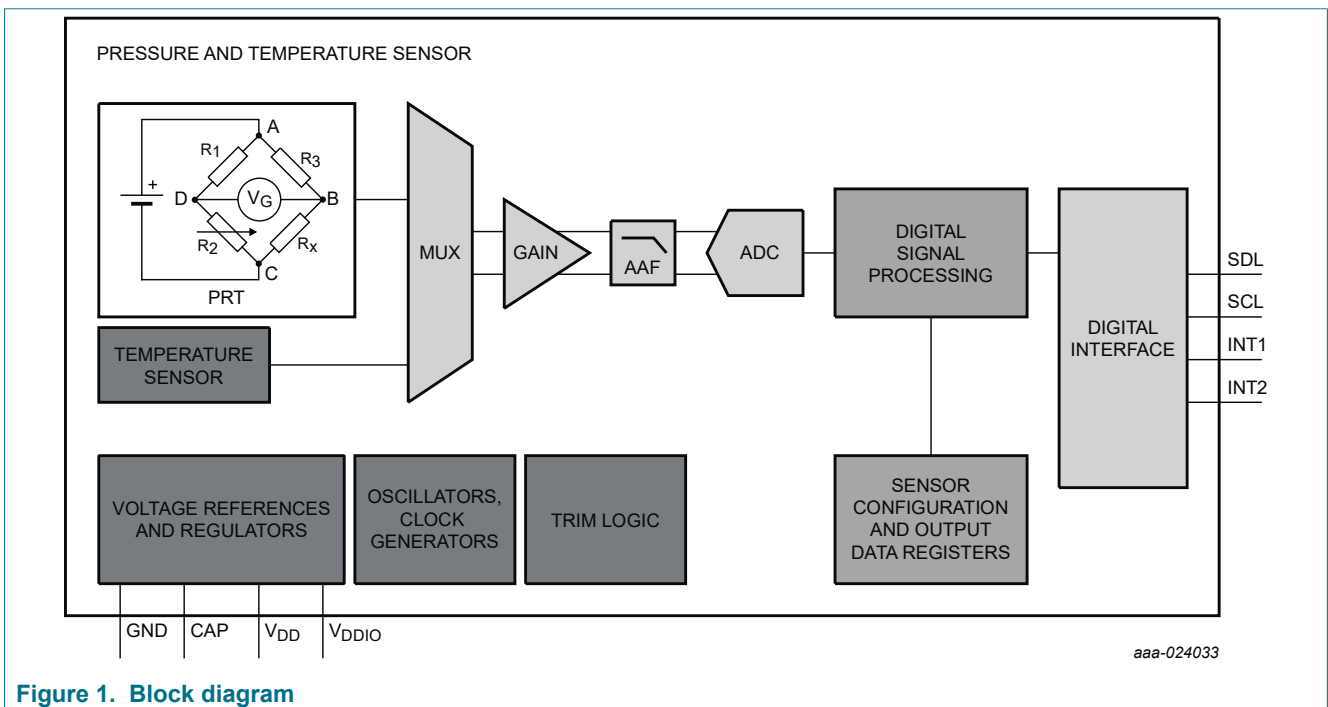
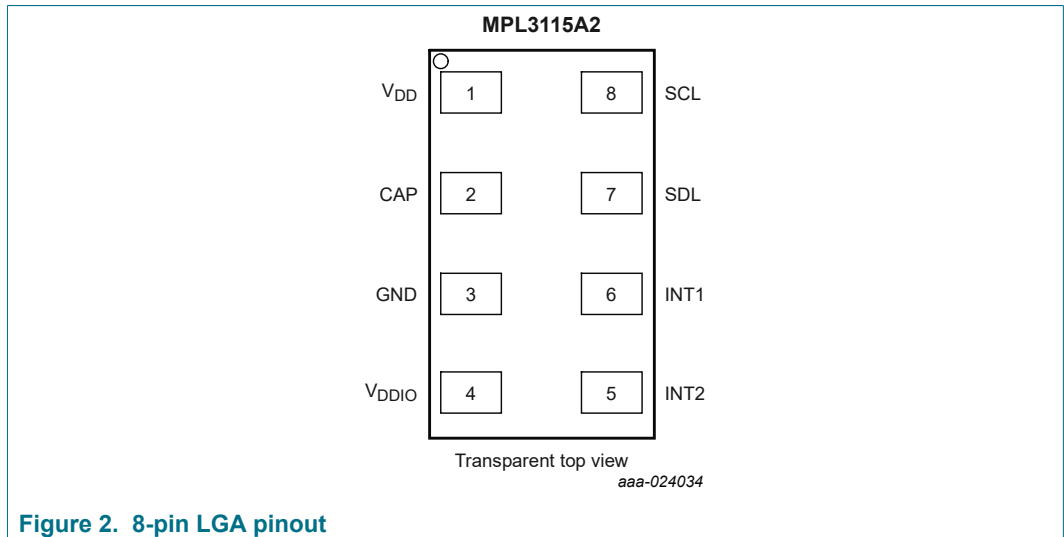

Figure 1. Block diagram

6 Pinning information

6.1 Pinning



6.2 Pin description

Table 2. Pin description

| Symbol | Pin | Description |
|-------------------|-----|---|
| V _{DD} | 1 | V _{DD} power supply connection (1.95 to 3.6 V) |
| CAP | 2 | External capacitor |
| GND | 3 | Ground |
| V _{DDIO} | 4 | Digital interface power supply (1.62 to 3.6 V) |
| INT2 | 5 | Pressure interrupt 2 |
| INT1 | 6 | Pressure interrupt 1 |
| SDL | 7 | I ² C serial data |
| SCL | 8 | I ² C serial clock |

7 System connections

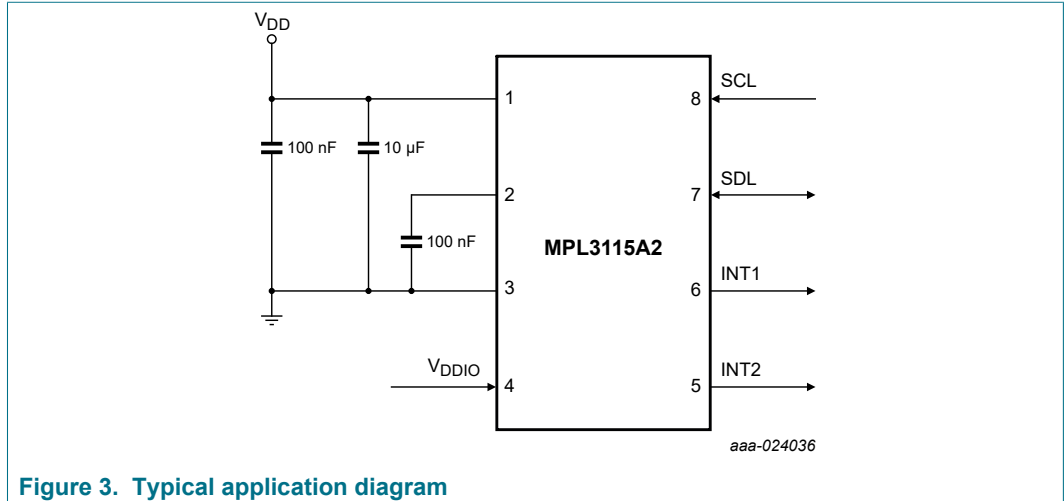

Figure 3. Typical application diagram

The device power is supplied through the V_{DD} line. Power supply decoupling capacitors (100 nF ceramic plus 10 μ F bulk or 10 μ F ceramic) should be placed as near as possible to pin 1 of the device. A second 100 nF capacitor is used to bypass the internal regulator. The functions, threshold and the timing of the interrupt pins (INT1 and INT2) are user programmable through the I²C interface.

8 Handling and board mount recommendations

The sensor die is sensitive to light exposure. Direct light exposure through the port hole can lead to varied accuracy of pressure measurement. Avoid such exposure to the port during normal operation.

8.1 Methods of handling

Components can be picked from the carrier tape using either the vacuum assist or the mechanical type pickup heads. A vacuum assist nozzle type is most common due to its lower cost of maintenance and ease of operation. The recommended vacuum nozzle configuration should be designed to make contact with the device directly on the metal cover and avoid vacuum port location directly over the vent hole in the metal cover of the device. Multiple vacuum ports within the nozzle may be required to effectively handle the device and prevent shifting during movement to placement position.

Vacuum pressure required to adequately support the component should be approximately 25 in Hg (85kPa). This level is typical of in-house vacuum supply. Pickup nozzles are available in various sizes and configurations to suit a variety of component geometries. To select the nozzle best suited for the specific application, it is recommended that the customer consult their pick and place equipment supplier to determine the correct nozzle. In some cases it may be necessary to fabricate a special nozzle depending on the equipment and speed of operation.

Tweezers or other mechanical forms of handling that have a sharp point are not recommended since they can inadvertently be inserted into the vent hole of the device. This can lead to a puncture of the MEMS element that will render the device inoperable.

8.2 Board mount recommendations

Components can be mounted using solder paste stencil, screen printed or dispensed onto the PCB pads prior to placement of the component. The volume of solder paste applied to the PCB is normally sufficient to secure the component during transport to the subsequent reflow soldering process. Use of adhesives to secure the component is not recommended, but where necessary can be applied to the underside of the device.

Solder pastes are available in variety of metal compositions, particle size and flux types. The solder paste consists of metals and flux required for a reliable connection between the component lead and the PCB pad. Flux aids the removal of oxides that may be present on PCB pads and prevents further oxidation from occurring during the solder process.

The use of a No-Clean (NC) flux is recommended for exposed cavity components. Using pressure spray, wire brush, or other methods of cleaning is not recommended since it can puncture the MEMS device and render it unusable. If cleaning of the pcb is performed Water Soluble (WS) flux can be used. However, it is recommended the component cavity is protected by adhesive Kapton tape, vinyl cap or other means prior to the cleaning process. This covering will prevent damage to the MEMS device, contamination, and foreign materials from being introduced into device cavity as result of cleaning processes.

Ultrasonic cleaning is not recommended as the frequencies can damage wire bond interconnections and the MEMS device.

9 Mechanical and electrical specifications

9.1 Terminology

9.1.1 Resolution

The resolution of a pressure sensor is the minimum change of pressure that can be reliably measured. The usable resolution of the device is programmable, enabling the user to choose a compromise between acquisition speed, power consumption, and resolution that best fits the application. To simplify the programming, the data is always reported in the same format with differing number of usable bits.

9.1.2 Accuracy

9.1.2.1 Offset

The offset is defined as the output signal obtained when the reference pressure (a vacuum for an absolute pressure sensor) is applied to the sensor. Offset error affects absolute pressure measurements but not relative pressure measurements. An altitude measurement is the pressure value in comparison to sea level, a barometric measurement is the pressure value read by the sensor. That is, a measurement of total pressure seen (for example 70 kPa), or total height (for example 3000 m) above sea level. A change in the offset will affect the pressure value or height seen above sea level as it shifts the sea level base reference. An absolute pressure measurement is not the same as relative pressure measurement, where the pressure is compared when raising

or lowering pressure in shorter intervals. This would be a walk up a hill, measuring the pressure and altitude difference from start to finish. In the relative case, the offset shifts are shared in the two absolute measurements and negate each other during the pressure calculation.

For the MPL3115A2, the long term offset shift can be removed by adjusting the pressure or altitude offset correction. See [Section 14.23 "Offset correction registers"](#). This adjustment is provided to override the factory programmed values to compensate for offsets introduced by manufacturing and mounting stresses. It is highly recommended that this is utilized to realize the full accuracy potential of the device.

9.1.2.2 Linearity

Linearity compares the slope of the measurement data to that of an ideal transfer function. It refers to how well a transducer's output follows the equation $P_{OUT} = P_{OFF} + \text{sensitivity} \times P$ straight-line equation over the operating pressure range. The method used by NXP to give the linearity specification is the end-point straight line method measured at midrange pressure.

9.1.2.3 Absolute pressure

Absolute pressure sensors measure an external pressure relative to a zero-pressure reference (vacuum) sealed inside the reference chamber of the die during manufacturing. This standard allows comparison to a standard value set such that 14.7 psi = 101,325 Pa = 1 atm at sea level as a measurement target. The absolute pressure is used to determine altitude as it has a constant reference for comparison. Measurement at sea level can be compared to measurement at a mountain summit as they use the same vacuum reference. The conversion of absolute pressure to altitude in meters is calculated based on US Standard Atmosphere 1976 (NASA).

Note: *Absolute pressure is not linear in relation to altitude, it is an exponential function. The value of altitude can be read directly from the device in increments of 0.0625 meters, or the value of pressure in 0.25 Pascal (Pa) units.*

9.1.2.4 Span

Span is the value of full-scale output with offset subtracted, representing the full range of the pressure sensor. Ideally the span is a specification over a constant temperature. The device uses internal temperature compensation to remove drift. Span accuracy is the comparison of the measured difference and the actual difference between the highest and lowest pressures in the specified range.

9.1.3 Pressure/altitude

The device is a high accuracy pressure sensor with integrated data calculation and logging capabilities. To provide altitude readings, the altitude calculations are based on the measured pressure (p), the user input of the equivalent sea level pressure to compensate for local weather conditions (OFF_H) and the US Standard Atmosphere 1976 (NASA). Pressure is given in Pascals (Pa), and fractions of a Pa. Altitude is given in meters (m) and fractions of a meter. The altitude is calculated from the pressure using the following equation:

$$h = 44330.77 \left\{ 1 - \left(\frac{p}{p_0} \right)^{0.1902632} \right\} + OFF_H \text{ (Register value)}$$

where:

p_0 = sea level pressure (101,326 Pa)
 h = altitude in meters

9.2 Absolute maximum ratings

Absolute maximum ratings are the limits the device can be exposed to without permanently damaging it. Absolute maximum ratings are stress ratings only, functional operation at these ratings is not guaranteed. Exposure to absolute maximum ratings conditions for extended periods may affect device reliability.

This device contains circuitry to protect against damage due to high static voltage or electrical fields. It is advised, however, that normal precautions be taken to avoid application of any voltages higher than maximum-rated voltages to this high-impedance circuit.

Table 3. Maximum ratings

| Symbol | Characteristic | Value | Unit |
|-------------------|---|---------------------------------|------|
| P _{max} | Maximum applied pressure | 500 | kPa |
| V _{DD} | Supply voltage | -0.3 to 3.6 | V |
| V _{DDIO} | Interface supply voltage | -0.3 to 3.6 | V |
| V _{IN} | Input voltage on any control pin (SCL, SDA) | -0.3 to V _{DDIO} + 0.3 | V |
| T _{OP} | Operating temperature range | -40 to +85 | °C |
| T _{STG} | Storage temperature range | -40 to +125 | °C |

Table 4. ESD and latchup protection characteristics

| Symbol | Rating | Value | Unit |
|--------|------------------------------|-------|------|
| HBM | Human body model | ±2000 | V |
| CDM | Charge device model | ±500 | V |
| — | Latchup current at T = 85 °C | ±100 | mA |

| | |
|---|---|
|  | Caution |
| | This device is sensitive to mechanical shock. Improper handling can cause permanent damage to the part or cause the part to otherwise fail. |

| | |
|---|--|
|  msc896 | Caution |
| | This is an ESD sensitive device. Improper handling can cause permanent damage to the part. |

9.3 Mechanical characteristics

Table 5. Mechanical characteristics

$V_{DD} = 2.5\text{ V}$, $T = 25\text{ °C}$, over 50 kPa to 110 kPa, unless otherwise noted.

| Symbol | Parameter | Test conditions | Min | Typ | Max | Unit |
|---------------------------|---|--|--------|-------|-----|--------|
| Pressure sensor | | | | | | |
| P _{FS} | Measurement range | Calibrated range | 50 | — | 110 | kPa |
| | | Operational range | 20 | — | 110 | kPa |
| | Pressure reading noise ^[1] | 1x oversample | — | 19 | — | Pa RMS |
| | | 128x oversample | — | 1.5 | — | Pa RMS |
| | Pressure absolute accuracy | 50 to 110 kPa over 0 °C to 50 °C | -0.4 | — | 0.4 | kPa |
| | | 50 to 110 kPa over -10 °C to 70 °C | — | ±0.4 | — | kPa |
| | Pressure relative accuracy | Relative accuracy during pressure change between 70 to 110 kPa at any constant temperature between -10 °C to 50 °C | — | ±0.05 | — | kPa |
| | | Relative accuracy during changing temperature between -10 °C to 50 °C at any constant pressure between 50 kPa to 110 kPa | — | ±0.1 | — | kPa |
| | Pressure/altitude resolution ^{[2][3][4]} | Barometer mode | 0.25 | 1.5 | — | Pa |
| | | Altimeter mode | 0.0625 | 0.3 | — | m |
| | Output data rate | One-shot mode | — | 100 | — | Hz |
| | | FIFO mode | — | — | 1 | Hz |
| | Board mount drift | After solder reflow | — | ±0.15 | — | kPa |
| | Long term drift | After a period of 1 year | — | ±0.1 | — | kPa |
| Temperature sensor | | | | | | |
| T _{FS} | Measurement range | — | -40 | — | +85 | °C |
| | Temperature accuracy | @25 °C | — | ±1 | — | °C |
| | | Over temperature range | — | ±3 | — | °C |
| T _{OP} | Operating temperature range | — | -40 | — | +85 | °C |

[1] Oversample (OSR) modes internally combine and average samples to reduce noise.

[2] Smallest bit change in register represents minimum value change in Pascals or meters. Typical resolution to signify change in altitude is 0.3 m.

[3] Reference pressure = 101.325 kPa (sea level).

[4] At 128x oversample ratio.

9.4 Electrical characteristics

Table 6. Electrical characteristics

@ V_{DD} = 2.5 V, T = 25 °C unless otherwise noted.

| Symbol | Parameter | Test conditions | Min | Typ | Max | Unit |
|--|---|---------------------------------------|------|-----|------|-------------------|
| V _{DDIO} | I/O supply voltage | — | 1.62 | 1.8 | 3.6 | V |
| V _{DD} | Operating supply voltage | — | 1.95 | 2.5 | 3.6 | V |
| I _{DD} | Integrated current 1 update per second | Highest speed mode oversample = 1 | — | 8.5 | — | μA |
| | | Standard mode oversample = 16 | — | 40 | — | μA |
| | | High resolution mode oversample = 128 | — | 265 | — | μA |
| I _{DDMAX} | Max current during acquisition and conversion | During acquisition/ conversion | — | 2 | — | mA |
| I _{DDSTBY} | Supply current drain in STANDBY mode | STANDBY mode selected SBYB = 0 | — | 2 | — | μA |
| VIH | Digital high level input voltage SCL, SDA | — | 0.75 | — | — | V _{DDIO} |
| VIL | Digital low level input voltage SCL, SDA | — | — | — | 0.3 | V _{DDIO} |
| VOH | High level output voltage INT1, INT2 | I _O = 500 μA | 0.9 | — | — | V _{DDIO} |
| VOL | Low level output voltage INT1, INT2 | I _O = 500 μA | — | — | 0.1 | V _{DDIO} |
| VOLS | Low level output voltage SDA | I _O = 500 μA | — | — | 0.1 | V _{DDIO} |
| T _{ON} | Turn-on time ^{[1][2][3]} | High speed mode | — | — | 60 | ms |
| | | High resolution mode | — | — | 1000 | ms |
| T _{OP} | Operating temperature range | — | -40 | 25 | +85 | °C |
| I²C addressing | | | | | | |
| I ² C Address | — | — | 0x60 | | | Hex |
| The device uses 7-bit addressing and does not acknowledge general call address 000 0000. Slave address has been set to 60h or 110 0000. 8-bit read is C1h, 8-bit write is C0h. | | | | | | |

[1] Time to obtain valid data from STANDBY mode to ACTIVE mode
 [2] High speed mode is achieved by setting the oversample rate of 1x.
 [3] High resolution mode is achieved by setting the oversample to 128x.

10 Digital interface

The registers embedded inside the device are accessed through an I²C serial interface.

Table 7. Serial interface pin descriptions

| Name | Description |
|------|-------------------------------|
| SCL | I ² C serial clock |
| SDA | I ² C serial data |

10.1 I²C characteristics

Table 8. I²C Slave timing values

All values referred to VIH(min) and VIL(max) levels.

| Symbol | Parameter | I ² C | | | Unit |
|---------------------|--|---|------------------------|-----|------|
| | | Condition | Min | Max | |
| f _{SCL} | SCL clock frequency | Pull-up = 1 kΩ, C _b = 400 pF | 0 | 400 | kHz |
| f _{SCL} | SCL clock frequency | Pull-up = 1 kΩ, C _b = 20 pF | 0 | 4 | MHz |
| t _{BUF} | Bus free time between STOP and START condition | — | 1.3 | — | μs |
| t _{HD;STA} | Repeated START hold time | — | 0.6 | — | μs |
| t _{SU;STA} | Repeated START setup time | — | 0.6 | — | μs |
| t _{SU;STO} | STOP condition setup time | — | 0.6 | — | μs |
| t _{HD;DAT} | SDA data hold time ^{[1][2][3]} | — | 50 | — | ns |
| t _{SU;DAT} | SDA setup time ^[4] | — | 100 | — | ns |
| t _{LOW} | SCL clock low time | — | 1.3 | — | μs |
| t _{HIGH} | SCL clock high time | — | 0.6 | — | μs |
| t _r | SDA and SCL rise time ^[5] | — | 20 + 0.1C _b | 300 | ns |
| t _f | SDA and SCL fall Time ^{[2][5][6][7]} | — | 20 + 0.1C _b | 300 | ns |
| t _{SP} | Pulse width of spikes that are suppressed by internal input filter | — | — | 50 | ns |

- [1] t_{HD;DAT} is the data hold time that is measured from the falling edge of SCL, applies to data in transmission and the acknowledge.
- [2] The device must internally provide a hold time of at least 300 ns for the SDA signal (with respect to the VIH(min) of the SCL signal) to bridge the undefined region of the falling edge of SCL
- [3] The maximum t_{HD;DAT} must be less than the maximum of t_{VD;DAT} or t_{VD;ACK} by a transition time. This device does not stretch the LOW period (t_{LOW}) of the SCL signal.
- [4] A fast mode I²C device can be used in a standard mode I²C system, but the requirement t_{SU;DAT} 250 ns must then be met. This will automatically be the case if the device does not stretch the LOW period of the SCL signal. If such a device does stretch the LOW period of the SCL signal, it must output the next data bit to the SDA line t_{r(max)} + t_{SU;DAT} = 1000 + 250 = 1250 ns (according to the standard mode I²C specification) before the SCL line is released. Also the acknowledge timing must meet this set-up time.
- [5] C_b = Total capacitance of one bus line in pF.
- [6] The maximum t_r for the SDA and SCL bus lines is specified at 300 ns. The maximum fall time for the SDA output stage t_f is specified at 250 ns. This allows series protection resistors to be connected in between the SDA and the SCL pins and the SDA/SCL bus lines without exceeding the maximum specified t_r.
- [7] In fast mode plus, fall time is specified the same for both output stage and bus timing. If series resistors are used, designers should allow for this when considering bus timing.

10.2 I²C operation

The transaction on the bus is started through a start condition (START) signal. START condition is defined as a HIGH to LOW transition on the data line while the SCL line is held HIGH. After START has been transmitted by the master, the bus is considered busy. The next byte of data transmitted after START contains the slave address in the first 7 bits, and the eighth bit tells whether the master is receiving data from the slave or transmitting data to the slave. When an address is sent, each device in the system compares the first seven bits after a start condition with its address. If they match, the device considers itself addressed by the master. The ninth clock pulse, following the slave address byte (and each subsequent byte) is the acknowledge (ACK). The transmitter must release the SDA line during the ACK period. The receiver must then pull the data line low so that it remains stable low during the high period of the acknowledge clock period.

The number of bytes per transfer is unlimited. If the master cannot receive another complete byte of data until it has performed some other function, it can hold the clock line, SCL low to force the transmitter into a wait state. Data transfer only continues when the master is ready for another byte and releases the clock line.

A low to high transition on the SDA line while the SCL line is high is defined as a stop condition (STOP). A data transfer is always terminated by a STOP. A master may also issue a repeated START during a data transfer. Device expects repeated STARTs to be used to randomly read from specific registers.

The standard 7-bit I²C slave address is 60h or 1100000. 8-bit read is C1h, 8-bit write is C0h.

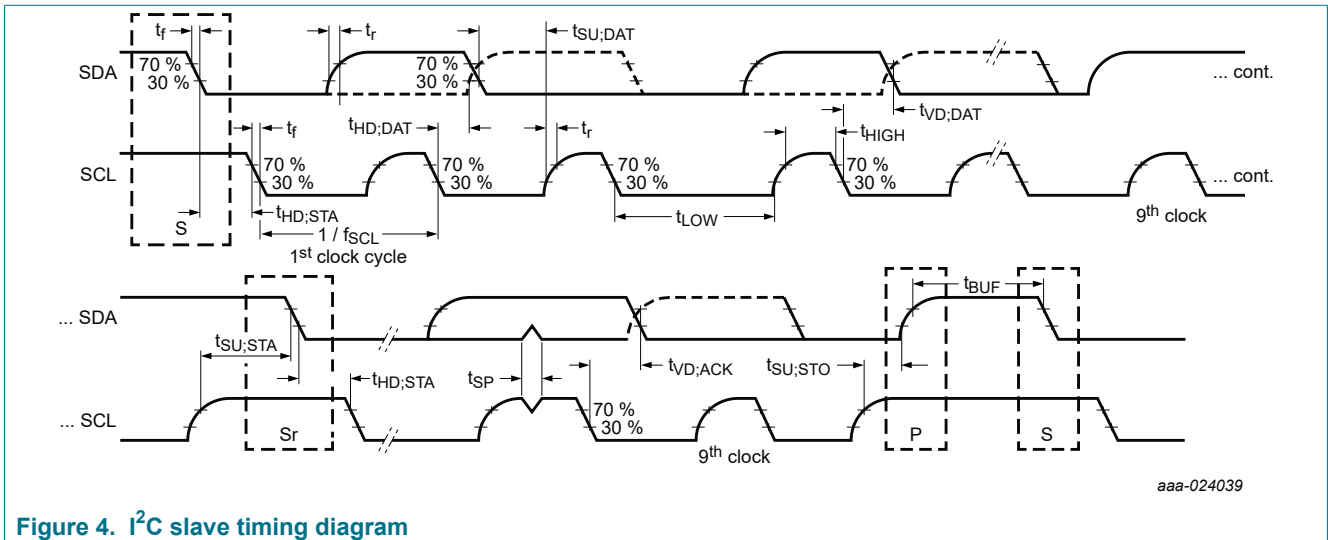

aaa-024039

Figure 4. I²C slave timing diagram

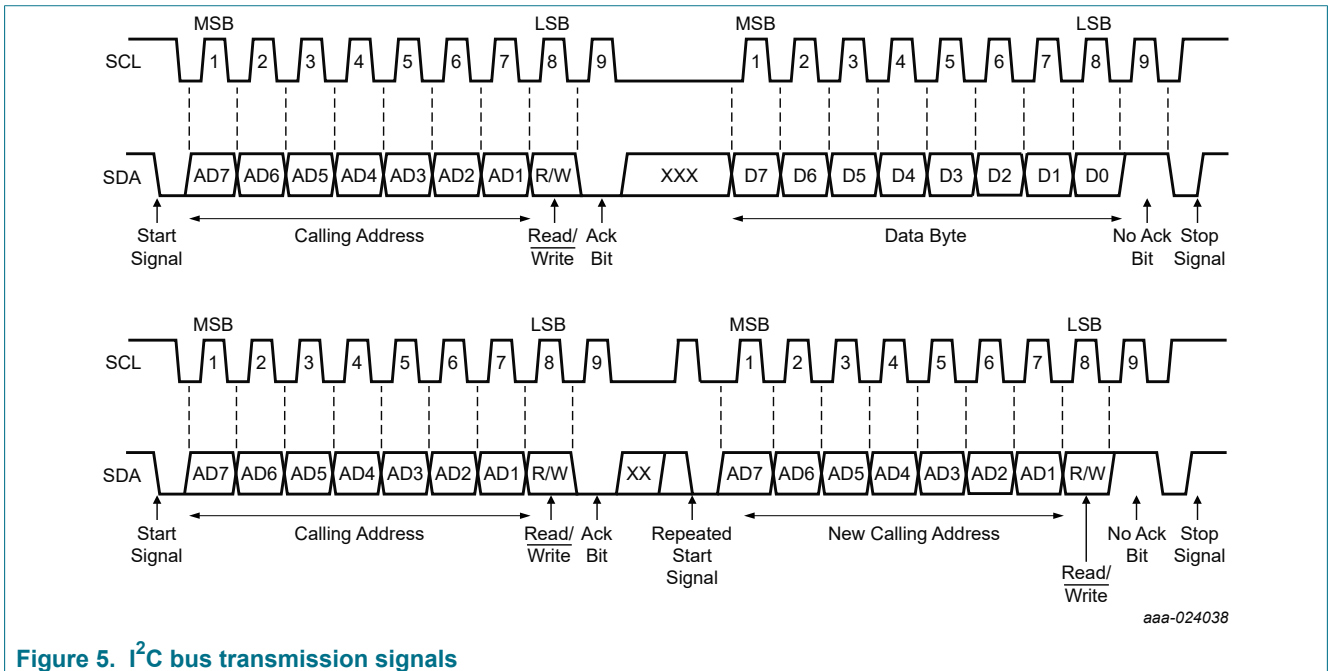

Figure 5. I²C bus transmission signals

Consult factory for alternate addresses. See the application note titled Sensor I²C Setup and FAQ (document AN4481).

11 Modes of operation

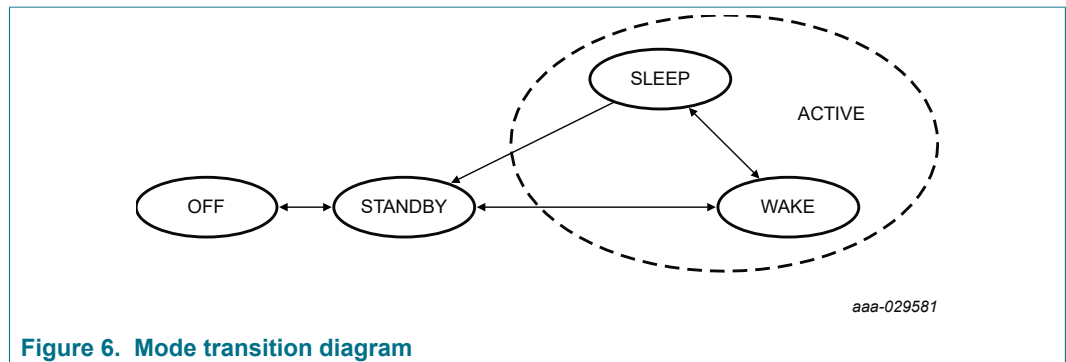

Figure 6. Mode transition diagram

Table 9. Mode of operation description

| Mode | I ² C-bus state | V _{DD} | Condition | Function description |
|---------|--|-----------------|----------------------------------|--|
| OFF | Powered down | < 1.62 V | < V _{DD} + 0.3 V | Device is powered off. |
| STANDBY | I ² C/SPI communication with the device is possible | ON | SBYB bit of CTRL_REG1 is cleared | Only POR and digital blocks are enabled. Analog subsystem is disabled. |
| ACTIVE | I ² C/SPI communication with the device is possible | ON | SBYB bit of CTRL_REG1 is set | All blocks are enabled (POR, digital, analog). |

11.1 OFF

Unit is powered down and has no operating functionality. V_{DD} and V_{DDIO} are not powered.

11.2 STANDBY

The digital sections are operational and the unit is capable of receiving commands and delivering stored data. The analog sections are off. The part is waiting for CTRL_REG1 to be configured and the part to enter active mode.

11.3 ACTIVE

Both analog and digital sections are running. The unit is capable of gathering new data, and accepting commands. The device is fully functional.

12 Quick start setup

To set up the device in altimeter mode, you may select your data retrieval method between polling (no FIFO), interrupt (no FIFO) or with the FIFO. The flow charts in [Figure 7](#) and [Figure 8](#) describe the setup for polling or interrupt with an OSR of 128.

For more information, see application note titled Data Manipulation and Basic Settings of the MPL3115A2 Command Line Interface (document AN4519).

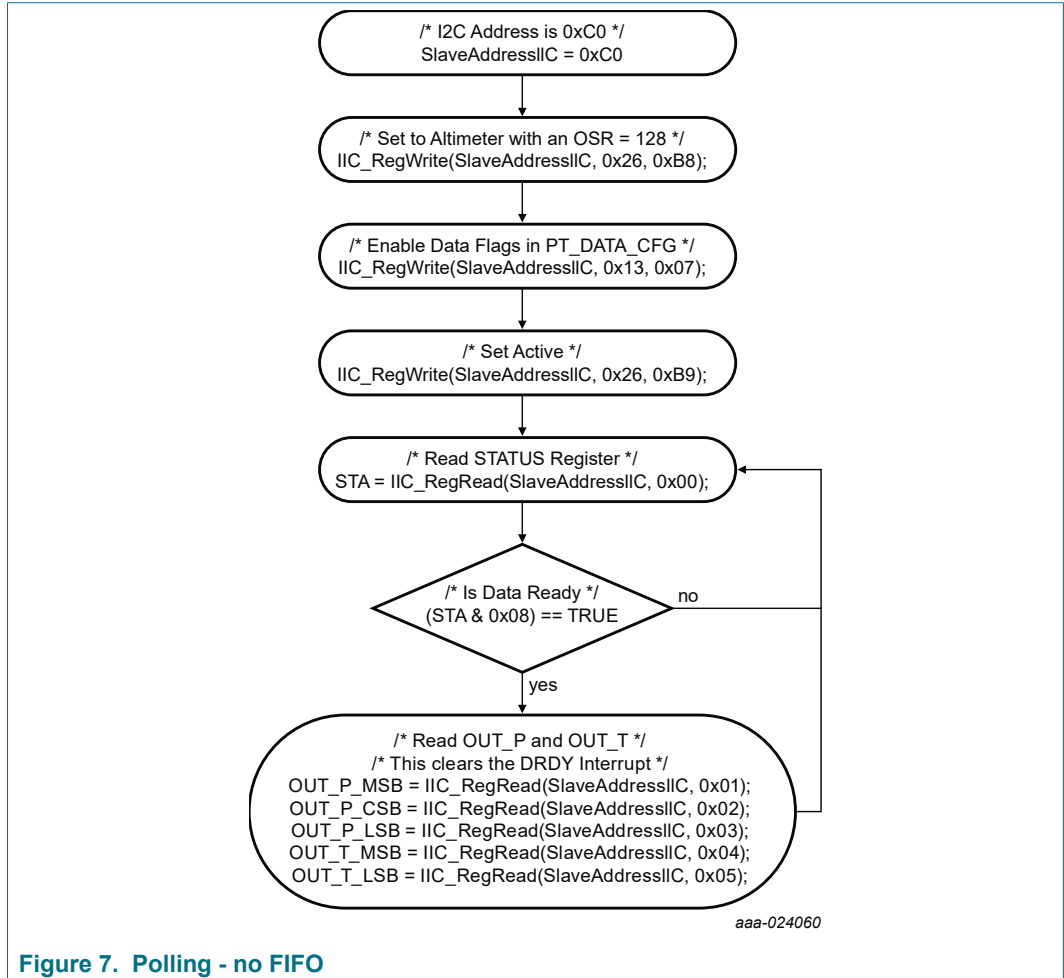

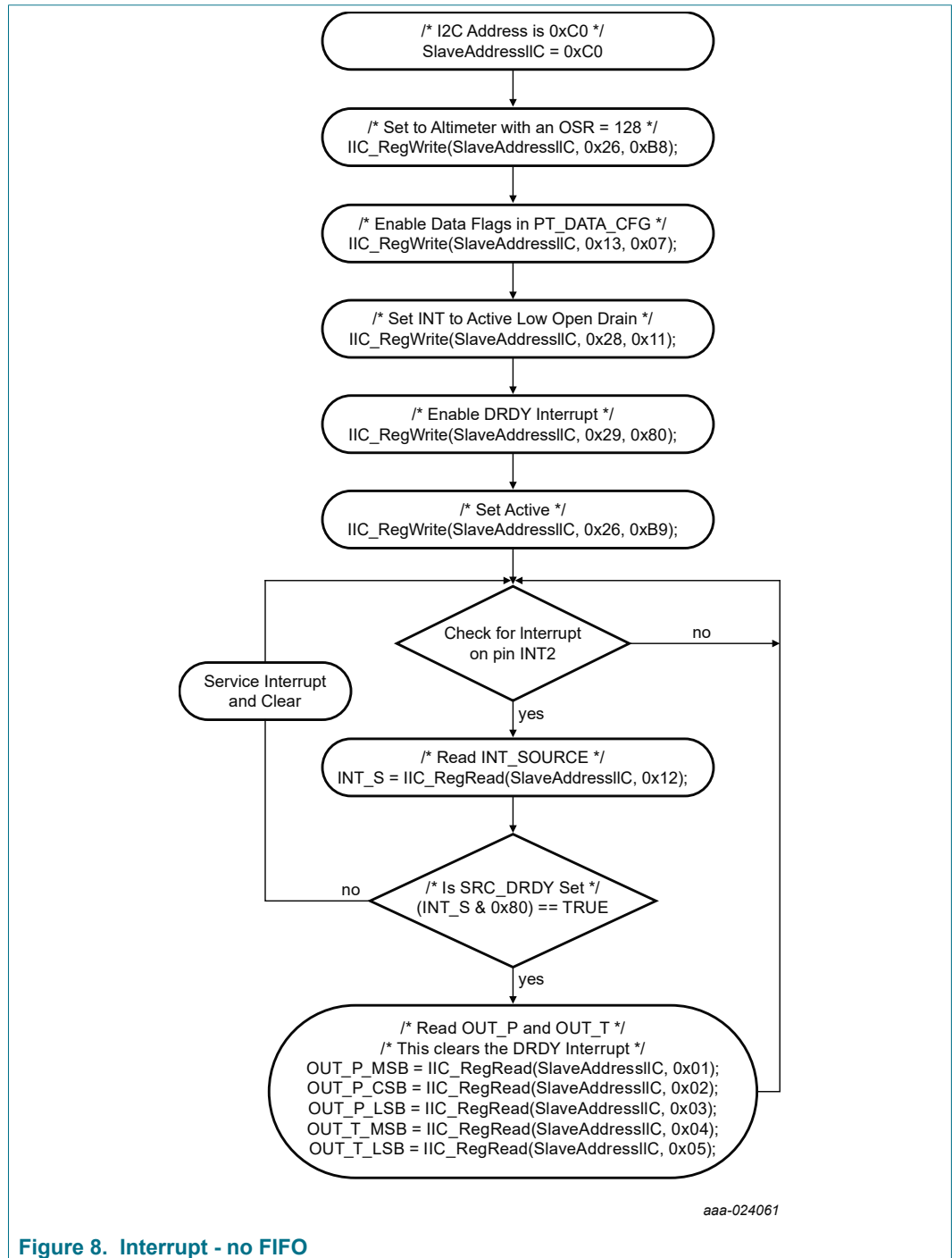

Figure 8. Interrupt - no FIFO

13 Functionality

The device is a low-power, high accuracy, digital output altimeter, barometer and thermometer, packaged in a 3 x 5 x 1.1 mm form factor. The complete device includes a sensing element, analog and digital signal processing and an I²C interface.

The device has two operational modes, barometer and altimeter. Both modes include a thermometer temperature output function.

Power consumption and sensitivity are programmable where the data oversampling ratio can be set to balance current consumption and noise/resolution. Serial interface communication is through an I²C interface thus making the device particularly suitable for direct interfacing with a microcontroller. The device features two independently programmable interrupt signals INT1 and INT2. These can be set to generate an interrupt signal when a new set of pressure/altitude and temperature data is available, thereby simplifying data acquisition for the host controller. These interrupt pins can also be configured to generate interrupts when a user programmed set of conditions are met (see [Section 13.6 "External interrupts"](#)).

Examples are:

- interrupt can be triggered when a single new data acquisition is ready
- when a desired number of samples are stored within the internal FIFO
- when a change of pressure/altitude or temperature is detected.

13.1 Factory calibration

The device is factory calibrated for sensitivity, offset for both temperature and pressure measurements. Trim values are stored on-chip, in non-volatile memory (NVM). In normal use, further calibration is not necessary. However, in order to realize the highest possible accuracy, the device allows the user to override the factory set offset values after power-up. The user adjustments are stored in volatile registers. The factory calibration values are not affected, and are always used by default on power-up.

13.2 Barometer/altimeter function

The mode of operation of the device can be selected as barometer or altimeter. The internal sensor gives an absolute pressure signal. The absolute pressure signal is processed to provide a scaled pressure or an altitude, depending on the mode selected. The combination of a high performance sensor and the signal processing enable resolution of pressures below 1 Pa and altitude resolution of better than 1 m at sea level.

When in barometer mode, all pressure related data is reported as 20-bit unsigned data in Pascals. When in altimeter mode, all pressure data is converted to equivalent altitude, based on the US standard atmosphere and then stored as 20-bit 2's complement value in meters and fractions of a meter.

13.2.1 Barometric input

In order to accurately determine the altitude by pressure, the OFF_H register (see [Section 14.23.3 "OFF_H - altitude data user offset register \(address 2Dh\)"](#)) is provided to input the local barometric pressure correction. The default value is 101,326 Pa since the BAR_IN_MSB and BAR_IN_LSB registers are in units of 2 Pascals per LSB.

13.3 Temperature function

The unit contains a high-resolution temperature sensor that provides data to the user via a 16-bit data register, as well as for internal compensation of the pressure sensor.

13.4 Autonomous data acquisition

The unit can be programmed to periodically capture pressure/altitude and temperature data. Up to 32 data acquisitions can be stored in the internal FIFO. The interval between acquisitions is programmable from one second to nine hours.

Data collection capabilities: (up to 32 samples over 12 days). The unit can also be programmed to make a single reading and then go to standby mode.

13.5 FIFO

A 32-sample FIFO is incorporated to minimize the overhead of collecting multiple data samples. The FIFO stores both temperature and pressure/altitude data. The device can be programmed to autonomously collect data at programmed intervals and store the data in the FIFO. FIFO interrupts can be triggered by watermark full or data contention (FIFO GATE) events.

13.6 External interrupts

Two independent interrupt out pins are provided. The configuration of the pins are programmable (polarity, open drain or push/pull.) Any one of the internal interrupt sources can be routed to either pin.

13.6.1 Reach target threshold pressure/altitude (SRC_PTH)

The interrupt flag is set on reaching the value stored in the pressure/altitude target register. Additionally, a window value provides the ability to signal when the target is nearing the value in the pressure/altitude target register from either above or below. When in barometer mode, these values represent pressures rather than altitudes.

Examples:

- Set altitude alert to 3000 m and window value to 100 m, interrupt is asserted passing 2900 m, 3000 m, and 3100 m.
- Set pressure alert to 100.0 kPa and window value to 5 kPa, interrupt can be sent passing 95 kPa, 100 kPa, and 105 kPa.

Note: When the window value is set to 0 then the interrupt will only be generated when reaching or crossing the target value.

13.6.2 Reach window target pressure/altitude (SRC_PW)

The interrupt flag is set when the pressure/altitude value is within the window defined by the following formula:

$$Window = P_TGT_{MSB,LSB} \pm P_WIND_{MSB,LSB}$$

Note: No interrupt is generated if the P_WND value is set to 0.

13.6.3 Reach target threshold temperature (SRC_TTH)

Interrupt flag is set on reaching the value stored in the temperature target register. Additionally a window value provides ability to signal when the target is nearing from either above or below the value in the temperature target register.

Note: When the window value is set to 0 then the interrupt will only be generated when reaching or crossing the target value.

13.6.4 Reach window target temperature (SRC_TW)

The interrupt flag is set when the temperature value is within the window defined by the following formula:

$$\text{Window} = T_{TGT} \pm T_{WIND}$$

Note: No interrupt is generated if the T_{WIND} value is set to 0.

13.6.5 Pressure/altitude change (SRC_PCHG)

Interrupt flag is set if sequential pressure/altitude acquisitions exceed value stored in pressure/altitude window value register.

13.6.6 Temperature change (SRC_TCHG)

Interrupt flag is set if sequential temperature acquisitions exceed the value stored in pressure/altitude window value register.

13.6.7 Data ready

Interrupt flag is set when new data or a data overwrite event has occurred. PTOW and/or PTDR (DR_STATUS register) must be set for an interrupt to be generated.

13.6.8 FIFO event

Interrupt flag is set when either an overflow or watermark event has occurred. For more information see [Section 14.8 "FIFO setup registers"](#).

13.6.9 Pressure/altitude and temperature delta

Registers show the differences from the last pressure/altitude and temperature samples.

13.6.10 Min/max data value storage

Registers record the minimum and maximum pressure/altitude and temperature.

14 Register descriptions

Table 10. Register address map

| Register Address | Name | Access | Reset value | Description | Reset when STBY to Active | Comment | Auto-increment address | Reference |
|------------------|-----------------|--------|-------------|---|---------------------------|---|------------------------|--------------------------------|
| 00h | STATUS | R | 00h | Sensor status register ^{[1],[2]} | Yes | Alias for DR_STATUS or F_STATUS | 01h | Section 14.1 |
| 01h | OUT_P_MSB | R | 00h | Pressure data out MSB ^{[1],[2]} | Yes | Bits 12 to 19 of 20-bit real-time pressure sample. Root pointer to pressure and temperature FIFO data. | 02h 01h | Section 14.3 |
| 02h | OUT_P_CSB | R | 00h | Pressure data out CSB ^{[1],[2]} | Yes | Bits 4 to 11 of 20-bit real-time pressure sample | 03h | Section 14.3 |
| 03h | OUT_P_LSB | R | 00h | Pressure data out LSB ^{[1],[2]} | Yes | Bits 0 to 3 of 20-bit real-time pressure sample | 04h | Section 14.3 |
| 04h | OUT_T_MSB | R | 00h | Temperature data out MSB ^{[1],[2]} | Yes | Bits 4 to 11 of 12-bit real-time temperature sample | 05h | Section 14.4 |
| 05h | OUT_T_LSB | R | 00h | Temperature data out LSB ^{[1],[2]} | Yes | Bits 0 to 3 of 12-bit real-time temperature sample | 00h | Section 14.4 |
| 06h/00h | DR_STATUS | R | 00h | Sensor status register ^{[1],[2]} | Yes | Data ready status information | 07h | Section 14.2 |
| 07h | OUT_P_DELTA_MSB | R | 00h | Pressure data out delta MSB ^{[1],[2]} | Yes | Bits 12 to 19 of 20-bit pressure change data | 08h | Section 14.5 |
| 08h | OUT_P_DELTA_CSB | R | 00h | Pressure data out delta CSB ^{[1],[2]} | Yes | Bits 4 to 11 of 20-bit pressure change data | 09h | Section 14.5 |
| 09h | OUT_P_DELTA_LSB | R | 00h | Pressure data out delta LSB ^{[1],[2]} | Yes | Bits 0 to 3 of 20-bit pressure change data | 0Ah | Section 14.5 |
| 0Ah | OUT_T_DELTA_MSB | R | 00h | Temperature data out delta MSB ^{[1],[2]} | Yes | Bits 4 to 11 of 12-bit temperature change data | 0Bh | Section 14.6 |
| 0Bh | OUT_T_DELTA_LSB | R | 00h | Temperature data out delta LSB ^{[1],[2]} | Yes | Bits 0 to 3 of 12-bit temperature change data | 06h | Section 14.6 |
| 0Ch | WHO_AM_I | R | C4hC5h | Device identification register | No | Fixed device ID number | 0Dh | Section 14.7 |
| 0Dh | F_STATUS | R | 00h | FIFO status register ^{[1],[2]} | Yes | FIFO status: no FIFO event detected | 0Eh | Section 14.8.1 |
| 0Eh/01h | F_DATA | R | 00h | FIFO 8-bit data access ^{[1],[2]} | Yes | FIFO 8-bit data access | 0Eh | Section 14.8.2 |
| 0Fh | F_SETUP | R/W | 00h | FIFO setup register ^{[1],[3]} | No | FIFO setup | 10h | Section 14.8.3 |
| 10h | TIME_DLY | R | 00h | Time delay register ^{[1],[2]} | Yes | Time since FIFO overflow | 11h | Section 14.9 |
| 11h | SYSMOD | R | 00h | System mode register ^[2] | Yes | Current system mode | 12h | Section 14.10 |
| 12h | INT_SOURCE | R | 00h | Interrupt source register ^[1] | No | Interrupt status | 13h | Section 14.11 |
| 13h | PT_DATA_CFG | R/W | 00h | PT data configuration register ^{[1],[3]} | No | Data event flag configuration | 14h | Section 14.12 |
| 14h | BAR_IN_MSB | R/W | C5h | BAR input in MSB ^{[1],[3]} | No | Barometric input for altitude calculation bits 8 to 15 | 15h | Section 14.13 |
| 15h | BAR_IN_LSB | R/W | E7h | BAR input in LSB ^{[1],[3]} | No | Barometric input for altitude calculation bits 0 to 7 | 16h | Section 14.13 |
| 16h | P_TGT_MSB | R/W | 00h | Pressure target MSB ^{[1],[3]} | No | Pressure/altitude target value bits 8 to 15 | 17h | Section 14.14 |
| 17h | P_TGT_LSB | R/W | 00h | Pressure target LSB ^{[1],[3]} | No | Pressure/altitude target value bits 0 to 7 | 18h | Section 14.14 |
| 18h | T_TGT | R/W | 00h | Temperature target register ^{[1],[3]} | No | Temperature target value | 19h | Section 14.15 |
| 19h | P_WND_MSB | R/W | 00h | Pressure/altitude window MSB ^{[1],[3]} | No | Pressure/altitude window value bits 8 to 15 | 1Ah | Section 14.16 |
| 1Ah | P_WND_LSB | R/W | 00h | Pressure/altitude window LSB ^{[1],[3]} | No | Pressure/altitude window value bits 0 to 7 | 1Bh | Section 14.16 |
| 1Bh | T_WND | R/W | 00h | Temperature window register ^{[1],[3]} | No | Temperature window value | 1Ch | Section 14.17 |
| 1Ch | P_MIN_MSB | R/W | 00h | Minimum pressure data out MSB ^{[1],[3]} | No | Minimum pressure/altitude bits 12 to 19 | 1Dh | Section 14.18 |
| 1Dh | P_MIN_CSB | R/W | 00h | Minimum pressure data out CSB ^{[1],[3]} | No | Minimum pressure/altitude bits 4 to 11 | 1Eh | Section 14.18 |
| 1Eh | P_MIN_LSB | R/W | 00h | Minimum pressure data out LSB ^{[1],[3]} | No | Minimum pressure/altitude bits 0 to 3 | 1Fh | Section 14.18 |

| Register Address | Name | Access | Reset value | Description | Reset when STBY to Active | Comment | Auto-increment address | Reference |
|------------------|-----------|--------|-------------|--|---------------------------|---|------------------------|---------------------------------|
| 1Fh | T_MIN_MSB | R/W | 00h | Minimum temperature data out MSB ^{[1][3]} | No | Minimum temperature bits 8 to 15 | 20h | Section 14.20 |
| 20h | T_MIN_LSB | R/W | 00h | Minimum temperature data out LSB ^{[1][3]} | No | Minimum temperature bits 0 to 7 | 21h | Section 14.20 |
| 21h | P_MAX_MSB | R/W | 00h | Maximum pressure data out MSB ^{[1][3]} | No | Maximum pressure/altitude bits 12 to 19 | 22h | Section 14.19 |
| 22h | P_MAX_CSB | R/W | 00h | Maximum pressure data out CSB ^{[1][3]} | No | Maximum pressure/altitude bits 4 to 11 | 23h | Section 14.19 |
| 23h | P_MAX_LSB | R/W | 00h | Maximum pressure data out LSB ^{[1][3]} | No | Maximum pressure/altitude bits 0 to 3 | 24h | Section 14.19 |
| 24h | T_MAX_MSB | R/W | 00h | Maximum temperature data out MSB ^{[1][3]} | No | Maximum temperature bits 8 to 15 | 25h | Section 14.21 |
| 25h | T_MAX_LSB | R/W | 00h | Maximum temperature data out LSB ^{[1][3]} | No | Maximum temperature bits 0 to 7 | 26h | Section 14.21 |
| 26h | CTRL_REG1 | R/W | 00h | Control register 1 ^{[1][4]} | No | Modes, oversampling | 27h | Section 14.22.1 |
| 27h | CTRL_REG2 | R/W | 00h | Control register 2 ^[1] | No | Acquisition time step | 28h | Section 14.22.2 |
| 28h | CTRL_REG3 | R/W | 00h | Control register 3 ^{[1][4]} | No | Interrupt pin configuration | 29h | Section 14.22.3 |
| 29h | CTRL_REG4 | R/W | 00h | Control register 4 ^{[1][4]} | No | Interrupt enables | 2Ah | Section 14.22.4 |
| 2Ah | CTRL_REG5 | R/W | 00h | Control register 5 ^{[1][4]} | No | Interrupt output pin assignment | 2Bh | Section 14.22.5 |
| 2Bh | OFF_P | R/W | 00h | Pressure data user offset register | No | Pressure data offset | 2Ch | Section 14.23 |
| 2Ch | OFF_T | R/W | 00h | Temperature data user offset register | No | Temperature data offset | 2Dh | Section 14.23.2 |
| 2Dh | OFF_H | R/W | 00h | Altitude data user offset register | No | Altitude data offset | 0Ch | Section 14.23.3 |

- [1] Register contents are preserved when transitioning from ACTIVE to STANDBY mode
- [2] Register contents are reset when transitioning from STANDBY to ACTIVE mode.
- [3] Register contents can be modified anytime in STANDBY or ACTIVE mode.
- [4] Modification of this register's contents can only occur when device in STANDBY mode except the SBYB, OST and RST bit fields in CTRL_REG1 register.

Table 11. Register address map: Area A (F_Mode = 0, FIFO disabled)

| Register Address | Name | Access | Reset value | Description | Reset when STBY to Active | Comment | Auto-increment address | Reference |
|------------------|--------------------------|--------|-------------|--------------------------|---------------------------|---|------------------------|------------------------------|
| 00h/06h | DR_STATUS ^[1] | R | 00h | Sensor status register | Yes | DR_STATUS | 01h | Section 14.2 |
| 01h | OUT_P_MSB ^[1] | R | 00h | Pressure data out MSB | Yes | Bits 12 to 19 of 20-bit real-time pressure sample. Root pointer to pressure and temperature FIFO data. | 02h 01h | Section 14.3 |
| 02h | OUT_P_CSB ^[1] | R | 00h | Pressure data out CSB | Yes | Bits 4 to 11 of 20-bit real-time pressure sample | 03h | Section 14.3 |
| 03h | OUT_P_LSB ^[1] | R | 00h | Pressure data out LSB | Yes | Bits 0 to 3 of 20-bit real-time pressure sample | 04h | Section 14.3 |
| 04h | OUT_T_MSB ^[1] | R | 00h | Temperature data out MSB | Yes | Bits 4 to 11 of 12-bit real-time temperature sample | 05h | Section 14.4 |
| 05h | OUT_T_LSB ^[1] | R | 00h | Temperature data out LSB | Yes | Bits 0 to 3 of 12-bit real-time temperature sample | 00h | Section 14.4 |

- [1] The Registers in Area A from 00h to 05h depend on the F_MODE bit setting in FIFO Setup Register (F_SETUP).
 - F_MODE = 00, FIFO is disabled.
 - F_MODE = 01 is circular buffer.
 - F_MODE = 10 is full stop mode.

Table 12. Register address map: Area A (F_Mode > 0, FIFO in circular buffer or full stop mode)

| Register Address | Name | Access | Reset value | Description | Reset when STBY to Active | Comment | Auto-increment address | Reference |
|------------------|---|--------|-------------|------------------------|---------------------------|----------|------------------------|--------------------------------|
| 00h/0Dh | F_STATUS ^[1] | R | 00h | Sensor status register | Yes | F_STATUS | 01h | Section 14.8.1 |
| 01h | F_DATA ^[1] | R | 00h | FIFO 8-bit data access | Yes | — | 01h | Section 14.8.2 |
| 02h | Read to reserved area returns 00 ^[1] | — | 00h | — | n.a. | — | 03h | — |
| 03h | Read to reserved area returns 00 ^[1] | — | 00h | — | n.a. | — | 04h | — |
| 04h | Read to reserved area returns 00 ^[1] | — | 00h | — | n.a. | — | 05h | — |
| 05h | Read to reserved area returns 00 ^[1] | — | 00h | — | n.a. | — | 00h | — |

[1] The registers in area A from 00h to 05h depend on the F_MODE bit setting in FIFO setup register (F_SETUP).

- F_MODE = 00, FIFO is disabled.
- F_MODE = 01 is circular buffer.
- F_MODE = 10 is full stop mode.

14.1 STATUS - sensor status register (address 00h)

The aliases allow the STATUS register to be read easily before reading the current pressure/altitude or temperature data, the delta pressure/altitude or temperature data, or the FIFO data, using the register address auto-incrementing mechanism.

Table 13. Alias for DR_Status (06h) or F_Status (0Dh) registers

| FIFO data enabled mode bit setting | Status register alias |
|------------------------------------|-----------------------|
| F_MODE = 00 ^[1] | 00h = DR_STATUS (06h) |
| F_MODE >00 | 00h = F_STATUS (0Dh) |

[1] The F_MODE is defined in [Section 14.8.3 "F_SETUP- FIFO setup register \(address 0Fh\)"](#)

14.2 DR_STATUS - status register (address 06h)

The DR_STATUS register provides the acquisition status information on a per sample basis, and reflects real-time updates to the OUT_P and OUT_T registers. The same STATUS register can be read through an alternate address 00h (F_Mode = 00).

Table 14. DR_STATUS - status register (address 06h) bit allocation

| Bit | 7 | 6 | 5 | 4 | 3 | 2 | 1 | 0 |
|--------|------|-----|-----|----------|------|-----|-----|----------|
| Symbol | PTOW | POW | TOW | reserved | PTDR | PDR | TDR | reserved |
| Reset | 0 | 0 | 0 | 0 | 0 | 0 | 0 | 0 |
| Access | R | R | R | R | R | R | R | R |

Table 15. DR_STATUS - status register (address 06h) bit description

| Bit | Symbol | Description |
|-----|---------------------|--|
| 7 | PTOW ^[1] | Pressure/altitude or temperature data overwrite. PTOW is set to 1 whenever new data is acquired before completing the retrieval of the previous set. This event occurs when the content of at least one data register (OUT_P, OUT_T) has been overwritten. PTOW is cleared when the high-bytes of the data (OUT_P_MSB or OUT_T_MSB) are read, when F_MODE is zero. PTOW is cleared by reading F_DATA register when F_MODE > 0. 0 — No data overwrite has occurred (reset value) 1 — Previous pressure/altitude or temperature data was overwritten by new pressure/altitude or temperature data before it was read |
| 6 | POW ^[2] | Pressure/altitude data overwrite. POW is set to 1 whenever a new pressure/altitude acquisition is completed before the retrieval of the previous data. When this occurs the previous data is overwritten. POW is cleared anytime OUT_P_MSB register is read, when F_MODE is zero. POW is cleared by reading F_DATA register when F_MODE > 0. 0 — No data overwrite has occurred (reset value) 1 — Previous pressure/altitude data was overwritten by new pressure/altitude data before it was read |
| 5 | TOW ^[3] | Temperature data overwrite. TOW is set to 1 whenever a new temperature acquisition is completed before the retrieval of the previous data. When this occurs the previous data is overwritten. TOW is cleared anytime OUT_T_MSB register is read, when F_MODE is zero. TOW is cleared by reading F_DATA register when F_MODE > 0. 0 — No data overwrite has occurred (reset value) 1 — Previous temperature data was overwritten by new temperature data before it was read |
| 4 | reserved | This bit is reserved |
| 3 | PTDR ^[1] | Pressure/altitude or temperature data ready. PTDR signals that a new acquisition for either pressure/altitude or temperature is available. PTDR is cleared anytime OUT_P_MSB or OUT_T_MSB register is read, when F_MODE is zero. PTDR is cleared by reading F_DATA register when F_MODE > 0. 0 — No new set of data ready (reset value) 1 — A new set of data is ready |
| 2 | PDR ^[2] | New pressure/altitude data available. PDR is set to 1 whenever a new pressure/altitude data acquisition is completed. PDR is cleared anytime OUT_P_MSB register is read, when F_MODE is zero. PDR is cleared by reading F_DATA register when F_MODE > 0. 0 — No new pressure/altitude data is available (reset value) 1 — A new set of pressure/altitude data is ready |
| 1 | TDR ^[3] | New temperature data available. TDR is set to 1 whenever a temperature data acquisition is completed. TDR is cleared anytime OUT_T_MSB register is read, when F_MODE is zero. TDR is cleared by reading F_DATA register when F_MODE > 0. 0 — No new temperature data ready (reset value) 1 — A new temperature data is ready |
| 0 | reserved | This bit is reserved |

[1] PTDR and PTOW flag generation requires the DREM event flag generator to be enabled in the PT data configuration register (PT_DATA_CFG).

[2] PDR and POW flag generation is required for the pressure/altitude event flag generator to be enabled (PDEFE = 1) in the PT data configuration register (PT_DATA_CFG).

[3] TDR and TOW flag generation is required for the temperature event flag generator to be enabled (TDEFE = 1) in the PT data configuration register (PT_DATA_CFG).

14.2.1 Data registers with F_MODE = 00 (FIFO disabled)

When the FIFO data output register, F_DATA (0Eh), is disabled (F_MODE[7:6] = 00 in the F_SETUP register, 0Fh), the pressure and altitude data registers indicate the

real-time status information of the sample data. This data can be either altimeter or barometer data based on the mode defined by the ALT bit in the CTRL_REG1 register. See [Section 14.8 "FIFO setup registers"](#) for additional information.

14.3 OUT_P_MSB, OUT_P_CSB, OUT_P_LSB - pressure and altitude data registers (address 01h, 02h, 03h)

Pressure and altitude data registers 01h, 02h and 03h comprise the pressure and altitude data depending on the setting of the ALT bit in the CTRL_REG1 register, in either altimeter or barometer mode. For example if the ALT bit is set (ALT = 1) then after acquisition the data stored in registers 01h, 02h and 03h is the altitude in meters. Otherwise the data stored in registers 01h, 02h and 03h (ALT = 0) is pressure data in Pascals.

The altitude data is stored as a 20-bit signed integer with a fractional part. The OUT_P_MSB (01h) and OUT_P_CSB (02h) registers contain the integer part in meters and the OUT_P_LSB (03h) register contains the fractional part. This value is represented as a Q16.4 fixed-point format where there are 16 integer bits (including the signed bit) and four fractional bits.

The pressure data is stored as a 20-bit unsigned integer with a fractional part. The OUT_P_MSB (01h), OUT_P_CSB (02h) and bits 7 to 6 of the OUT_P_LSB (03h) registers contain the integer part in Pascals. Bits 5 to 4 of OUT_P_LSB contain the fractional component. This value is representative as a Q18.2 fixed point format where there are 18 integer bits and two fractional bits.

Table 16. OUT_P_MSB, OUT_P_CSB, OUT_P_LSB - pressure and altitude data registers (address 01h, 02h, 03h) bit allocation

| Location | | Bit | | | | | | | | |
|----------|-----------|-----------|---|---|---|----------|---|---|---|--|
| Address | Register | 7 | 6 | 5 | 4 | 3 | 2 | 1 | 0 | |
| 01h | OUT_P_MSB | PD[19:12] | | | | | | | | |
| 02h | OUT_P_CSB | PD[11:4] | | | | | | | | |
| 03h | OUT_P_LSB | PD[3:0] | | | | reserved | | | | |
| Reset | | 0 | 0 | 0 | 0 | 0 | 0 | 0 | 0 | |
| Access | | R | R | R | R | R | R | R | R | |

14.3.1 Data registers with F_MODE = 00

The DR_STATUS, OUT_P_MSB, OUT_P_CSB, OUT_P_LSB, OUT_T_MSB, and OUT_T_LSB registers are stored in the auto-incrementing address range of 00h to 05h. This allows the host controller to read the status register followed by the 20-bit pressure/altitude and 12-bit temperature in a 6-byte I²C transaction.

See [Section 14.8 "FIFO setup registers"](#) for additional information.

14.4 OUT_T_MSB, OUT_T_LSB - temperature data registers (address 04h, 05h)

The temperature data is stored as a signed 12-bit integer with a fractional part. The OUT_T_MSB (04h) register contains the integer part in °C and the OUT_T_LSB (05h)

register contains the fractional part. This value is representative as a Q8.4 fixed point format where there are eight integer bits (including the signed bit) and four fractional bits.

Table 17. OUT_T_MSB, OUT_T_LSB - temperature data registers (address 04h, 05h) bit allocation

| Location | | Bit | | | | | | | |
|----------|-----------|----------|---|---|---|----------|---|---|---|
| Address | Register | 7 | 6 | 5 | 4 | 3 | 2 | 1 | 0 |
| 04h | OUT_T_MSB | TD[11:4] | | | | | | | |
| 05h | OUT_T_LSB | TD[3:0] | | | | reserved | | | |
| Reset | | 0 | 0 | 0 | 0 | 0 | 0 | 0 | 0 |
| Access | | R | R | R | R | R | R | R | R |

14.5 OUT_P_DELTA_MSB, OUT_P_DELTA_CSB, OUT_P_DELTA_LSB - pressure and altitude delta register (address 07h, 08h, 09h)

The pressure and altitude delta registers 07h, 08h and 09h comprise the pressure and altitude delta data and provide the differences from either the last pressure or altitude samples based on the setting of the ALT bit in the CTRL_REG1 register. Device can be in either altimeter or barometer mode.

The altitude data is arranged as a 20-bit signed integer with a fractional part. Stored as meters with the 16 bits of OUT_P_DELTA_MSB and OUT_P_DELTA_CSB and with fractions of a meter stored in four bits in position 7 to 4 of OUT_P_DELTA_LSB.

The pressure is arranged as a 20-bit unsigned integer with a fractional part in Pascals. The first 18 bits are located in OUT_P_DELTA_MSB, OUT_P_DELTA_CSB and bits 7 to 6 of OUT_P_DELTA_LSB. The two bits in position 5 to 4 of OUT_P_DELTA_LSB represent the fractional component.

Note: The OUT_P_DELTA register store the difference data information regardless of the state of the FIFO data output register driver bit, F_MODE > 00.

Table 18. OUT_P_DELTA_MSB, OUT_P_DELTA_CSB, OUT_P_DELTA_LSB - pressure and altitude delta register (address 07h, 08h, 09h) bit allocation

| Location | | Bit | | | | | | | |
|----------|-----------------|------------|---|---|---|----------|---|---|---|
| Address | Register | 7 | 6 | 5 | 4 | 3 | 2 | 1 | 0 |
| 07h | OUT_P_DELTA_MSB | PDD[19:12] | | | | | | | |
| 08h | OUT_P_DELTA_CSB | PDD[11:4] | | | | | | | |
| 09h | OUT_P_DELTA_LSB | PDD[3:0] | | | | reserved | | | |
| Reset | | 0 | 0 | 0 | 0 | 0 | 0 | 0 | 0 |
| Access | | R | R | R | R | R | R | R | R |

14.6 OUT_T_DELTA_MSB, OUT_T_DELTA_LSB - temperature delta register (address 0Ah, 0Bh)

The temperature delta register 0Ah and 0Bh comprise the temperature delta data and provide the difference from the last temperature samples.

The temperature data is arranged as 12-bit signed integer with a fractional part in °C. The eight bits of OUT_T_DELTA_MSB representing degrees and with fractions of a degree stored in four bits in position 7 to 4 of OUT_T_DELTA_LSB.

Note: The OUT_T_DELTA register store the difference data information regardless of the state of the FIFO data output register driver bit, F_MODE > 00.

Table 19. OUT_T_DELTA_MSB, OUT_T_DELTA_LSB - temperature delta register (address 0Ah, 0Bh) bit allocation

| Location | | Bit | | | | | | | |
|----------|-----------------|-----------|---|---|---|----------|---|---|---|
| Address | Register | 7 | 6 | 5 | 4 | 3 | 2 | 1 | 0 |
| 0Ah | OUT_T_DELTA_MSB | TDD[11:4] | | | | | | | |
| 0Bh | OUT_T_DELTA_LSB | TDD[3:0] | | | | reserved | | | |
| Reset | | 0 | 0 | 0 | 0 | 0 | 0 | 0 | 0 |
| Access | | R | R | R | R | R | R | R | R |

14.7 WHO_AM_I - device ID register (address 0Ch)

This register contains the device identifier which is set to C4h by default. The value is factory programmed. Consult the NXP factory for custom alternate values.

Table 20. WHO_AM_I - device ID register (address 0Ch) bit allocation

| Bit | 7 | 6 | 5 | 4 | 3 | 2 | 1 | 0 |
|--------|---------------|---------------|---------------|---------------|---------------|---------------|---------------|---------------|
| Symbol | WHO_AM_I[7:0] | | | | | | | |
| Reset | 0 | 0 | 0 | 0 | 0 | 0 | 0 | 0 |
| Access | NVM data 1 | NVM data 1 | NVM data 0 | NVM data 0 | NVM data 0 | NVM data 1 | NVM data 0 | NVM data 0 |

14.8 FIFO setup registers

14.8.1 F_STATUS - FIFO status register (address 0Dh)

Table 21. F_STATUS - FIFO status register (address 0Dh) bit allocation

| Bit | 7 | 6 | 5 | 4 | 3 | 2 | 1 | 0 |
|--------|-------|-------------|------------|---|---|---|---|---|
| Symbol | F_OVF | F_WMRK_FLAG | F_CNT[5:0] | | | | | |
| Reset | 0 | 0 | 0 | 0 | 0 | 0 | 0 | 0 |
| Access | R | R | R | R | R | R | R | R |

Table 22. F_STATUS - FIFO status register (address 0Dh) bit description

| F_OVF | F_WMRK_FLAG | Event description |
|-------|-------------|---|
| 0 | — | No FIFO overflow events detected. |
| 1 | — | FIFO overflow event detected. |
| — | 0 | No FIFO watermark events detected. |
| — | 1 | FIFO watermark event detected. FIFO sample count greater than watermark value |

The F_OVF and F_WMRK_FLAG flags remain asserted while the event source is still active, but the user can clear the FIFO interrupt bit flag in the interrupt source register (INT_SOURCE) by reading the F_STATUS register. Therefore, the F_OVF bit flag will remain asserted while the FIFO has overflowed and the F_WMRK_FLAG bit flag will remain asserted while the F_CNT value is greater than then F_WMRK value.

Table 23. F_STATUS - FIFO status register (address 0Dh) bit description

| Bit | Symbol | Description |
|--------|--------|---|
| 5 to 0 | F_CNT | FIFO sample counter. F_CNT[5:0] bits indicate the number of samples currently stored in the FIFO buffer. 00_0000 — indicates that the FIFO is empty (reset value) 00_0001 to 10_0000 — indicates 1 to 32 samples stored in FIFO |

14.8.2 F_DATA - FIFO data register (address 0Eh)

F_DATA is a read only address which provides access to 8-bit FIFO data. FIFO holds a maximum of 32 samples, a maximum of 5 × 32 = 160 data bytes of samples can be read. When F_MODE bit in FIFO SETUP (F_SETUP) register is set to logic '1', the F_DATA pointer shares the same address location as OUT_P_MSB (01h), therefore all accesses of the FIFO buffer data use the I²C address 01h. Reads from the other data registers (02h, 03h, 04h, 05h) will return a value of 00h.

Note: The FIFO will NOT suspend to data accumulation during read transactions to F_DATA.

Table 24. F_DATA - FIFO data register (address 0Eh) bit allocation

| Bit | 7 | 6 | 5 | 4 | 3 | 2 | 1 | 0 |
|--------|-------------|---|---|---|---|---|---|---|
| Symbol | F_DATA[7:0] | | | | | | | |
| Reset | 0 | 0 | 0 | 0 | 0 | 0 | 0 | 0 |
| Access | R | R | R | R | R | R | R | R |

Table 25. Read accesses through F_DATA

| | |
|---------------------|--------------------|
| 1st read (1 byte) | OUT_P_MSB (oldest) |
| 2nd read (1 byte) | OUT_P_CSB (oldest) |
| 3rd read (1 byte) | OUT_P_LSB (oldest) |
| 4th read (1 byte) | OUT_T_MSB (oldest) |
| 5th read (1 byte) | OUT_T_LSB (oldest) |
| . | . |
| . | . |
| . | . |
| 158th read (1 byte) | OUT_T_LSB (oldest) |
| 159th read (1 byte) | 00h |
| 160th read (1 byte) | 00h |

14.8.3 F_SETUP- FIFO setup register (address 0Fh)

A FIFO sample count exceeding the watermark event does not stop the FIFO from accepting new data.

The FIFO update rate is dictated by the selected system acquisition rate (ST bits of CTRL_REG2).

When a byte is read from the FIFO buffer the oldest sample data in the FIFO buffer is returned and also deleted from the front of the FIFO buffer, while the FIFO sample count is decremented by one. It is assumed that the host application shall use the I²C BURST read transaction to dump the FIFO.

Table 26. F_SETUP- FIFO setup register (address 0Fh) bit allocation

| Bit | 7 | 6 | 5 | 4 | 3 | 2 | 1 | 0 |
|--------|-------------|---|-------------|---|---|---|---|---|
| Symbol | F_MODE[1:0] | | F_WMRK[5:0] | | | | | |
| Reset | 0 | 0 | 0 | 0 | 0 | 0 | 0 | 0 |
| Access | R | R | R | R | R | R | R | R |

Table 27. F_SETUP- FIFO setup register (address 0Fh) bit description

| Bit | Symbol | Description |
|--------|-------------------------------|--|
| 7 to 6 | F_MODE[7:6] ^{[1][2]} | <p>FIFO buffer overflow mode.</p> <p>00 — FIFO is disabled (reset value)</p> <p>01 — FIFO contains the most recent samples when overflowed (circular buffer). Oldest sample is discarded to be replaced by new sample</p> <p>10 — FIFO stops accepting new samples when overflowed</p> <p>11 — Not used</p> <p>The FIFO is flushed whenever the FIFO is disabled, or transitioning from STANDBY mode to ACTIVE mode. Disabling the FIFO (F_MODE = 00) resets the F_OVF, F_WMRK_FLAG, F_CNT to zero. A FIFO overflow event (as when F_CNT = 32) will assert the F_OVF flag and a FIFO sample count equal to the sample count watermark (F_WMRK) asserts the F_WMRK_FLAG event flag. To switch between FIFO modes, first disable the FIFO and then write the new value to F_MODE.</p> |
| 5 to 0 | F_WMRK[5:0] ^[3] | <p>FIFO event sample count watermark. These bits set the number of FIFO samples required to trigger a watermark interrupt. A FIFO watermark event flag (F_WMRK_FLAG) is raised when FIFO sample count F_CNT[5:0] value is equal to the F_WMRK[5:0] watermark.</p> <p>00_0000 — FIFO is disabled (reset value) Setting the F_WMRK[5:0] to 00_0000 will disable the FIFO watermark event flag generation.</p> |

[1] This bit field can be written in ACTIVE mode.

[2] This bit field can be written in STANDBY mode.

[3] The FIFO mode (F_MODE) cannot be switched between the two operational modes (01 and 10).

14.9 TIME_DLY - time delay register (address 10h)

The time delay register contains the number of ticks of data sample time since the last byte of the FIFO was written. This register starts to increment on FIFO overflow or data wrap and clears when the last byte of FIFO is read.

Table 28. TIME_DLY - time delay register (address 10h) bit allocation

| Bit | 7 | 6 | 5 | 4 | 3 | 2 | 1 | 0 |
|--------|---------|---|---|---|---|---|---|---|
| Symbol | TD[7:0] | | | | | | | |
| Reset | 0 | 0 | 0 | 0 | 0 | 0 | 0 | 0 |
| Access | R | R | R | R | R | R | R | R |

14.10 SYSMOD - system mode register (address 11h)

Table 29. SYSMOD - system mode register (address 11h) bit allocation

| Bit | 7 | 6 | 5 | 4 | 3 | 2 | 1 | 0 |
|--------|----------|---|---|---|---|---|---|--------|
| Symbol | reserved | | | | | | | SYSMOD |
| Reset | 0 | 0 | 0 | 0 | 0 | 0 | 0 | 0 |
| Access | R | R | R | R | R | R | R | R |

Table 30. SYSMOD - system mode register (address 11h) bit description

| Bit | Symbol | Description |
|--------|----------|--|
| 7 to 1 | reserved | These bits are reserved and will always read 0 |
| 0 | SYSMOD | System mode 0 — STANDBY mode (reset value) 1 — ACTIVE mode |

14.11 INT_SOURCE - system interrupt status register (address 12h)

The interrupt source register bits that are set (logic '1') to indicate which function has asserted its interrupt and conversely, bits that are cleared (logic '0') indicate which function has not asserted its interrupt.

The setting of the bits is rising edge sensitive, the bit is set by a low to high state change and reset by reading the appropriate source register.

Table 31. INT_SOURCE - system interrupt status register (address 12h) bit allocation

| Bit | 7 | 6 | 5 | 4 | 3 | 2 | 1 | 0 |
|--------|----------|----------|--------|--------|---------|---------|----------|----------|
| Symbol | SRC_DRDY | SRC_FIFO | SRC_PW | SRC_TW | SRC_PTH | SRC_TTH | SRC_PCHG | SRC_TCHG |
| Reset | 0 | 0 | 0 | 0 | 0 | 0 | 0 | 0 |
| Access | R | R | R | R | R | R | R | R |

Table 32. INT_SOURCE - system interrupt status register (address 12h) bit description

| Bit | Symbol | Description |
|-----|----------|--|
| 7 | SRC_DRDY | Data ready interrupt status bit. Logic '1' indicates that pressure/altitude or temperature data ready interrupt is active indicating the presence of new data and/or a data overwrite, otherwise it is a logic '0'. This bit is asserted when the PTOW and/or PTDR is set and the functional block interrupt has been enabled. This bit is cleared by reading the STATUS and pressure/temperature register. |
| 6 | SRC_FIFO | FIFO interrupt status bit. Logic '1' indicates that a FIFO interrupt event such as an overflow event has occurred. FIFO interrupt event generators: FIFO overflow, or (watermark: F_CNT = F_WMRK). 0 — no FIFO interrupt event has occurred. (reset value) This bit is cleared by reading the F_STATUS register. 1 — A FIFO interrupt event such as an overflow event has occurred. |
| 5 | SRC_PW | Pressure/altitude alerter status bit near or equal to target pressure/altitude (near is within target value \pm window value). 0 — (reset value) Window value needs to be non zero for interrupt to trigger. |
| 4 | SRC_TW | Temperature alerter status bit near or equal to target temperature (near is within target value \pm window value.) 0 — (reset value) Window value needs to be non zero for interrupt to trigger. |

| Bit | Symbol | Description |
|-----|----------|---|
| 3 | SRC_PTH | Pressure/altitude threshold interrupt. 0 — If the window is set to 0, it will only trigger on crossing the center threshold. (reset value) 1 — With the window set to a non zero value, the trigger will occur on crossing any of the thresholds: upper, center or lower. |
| 2 | SRC_TTH | Temperature threshold interrupt. 0 — If the window is set to 0, it will only trigger on crossing the center threshold.(reset value) 1 — With the window set to a non zero value, the trigger will occur on crossing any of the thresholds: upper, center or lower. |
| 1 | SRC_PCHG | Delta P interrupt status bit. 0 — (reset value) |
| 0 | SRC_TCHG | Delta T interrupt status bit. 0 — (reset value) |

14.12 PT_DATA_CFG - sensor data register (address13h)

The PT_DATA_CFG register configures the pressure data, temperature data and event flag generator.

Table 33. PT_DATA_CFG - sensor data register (address13h) bit allocation

| Bit | 7 | 6 | 5 | 4 | 3 | 2 | 1 | 0 |
|--------|----------|---|---|---|---|------|-------|-------|
| Symbol | reserved | | | | | DREM | PDEFE | TDEFE |
| Reset | 0 | 0 | 0 | 0 | 0 | 0 | 0 | 0 |
| Access | R | R | R | R | R | R/W | R/W | R/W |

Table 34. PT_DATA_CFG - sensor data register (address13h) bit description

| Bit | Symbol | Description |
|--------|----------|---|
| 7 to 3 | reserved | These bits are reserved |
| 2 | DREM | Data ready event mode. 0 — Event detection disabled (reset value) If the DREM bit is cleared logic '0' and one or more of the data ready event flags are enabled, then an event flag will be raised whenever the system acquires a new set of data. 1 — Generate data ready event flag on new pressure/altitude or temperature data. If the DREM bit is set logic '1' and one or more of the data ready event flags (PDEFE, TDEFE) are enabled, then an event flag will be raised upon change in state of the data. |
| 1 | PDEFE | Data event flag enable on new pressure/altitude 0 — Event detection disabled (reset value) 1 — Raise event flag on new pressure/altitude data |
| 0 | TDEFE | Data event flag enable on new temperature data. 0 — Event detection disabled (reset value) 1 — Raise event flag on new temperature data |

14.13 BAR_IN_MSB, BAR_IN_LSB - barometric pressure input register (address 14h, 15h)

Barometric input for altitude calculations. Input is equivalent to sea level pressure for measurement location. Value is input in two Pa units.

Units are input as unsigned 16-bit integers. The default value is 101,326 Pa. The default value can be changed by writing to this register.

Table 35. BAR_IN_MSB, BAR_IN_LSB - barometric pressure input register (address 14h, 15h) bit allocation

| Location | | Bit | | | | | | | |
|-----------|------------|-----------|-----|-----|-----|-----|-----|-----|-----|
| Address | Register | 7 | 6 | 5 | 4 | 3 | 2 | 1 | 0 |
| 14h | BAR_IN_MSB | BAR[15:8] | | | | | | | |
| 15h | BAR_IN_LSB | BAR[7:0] | | | | | | | |
| Reset MSB | | 1 | 1 | 0 | 0 | 0 | 1 | 0 | 1 |
| Reset LSB | | 1 | 1 | 1 | 0 | 0 | 1 | 1 | 1 |
| Access | | R/W | R/W | R/W | R/W | R/W | R/W | R/W | R/W |

14.14 P_TGT_MSB, P_TGT_LSB - pressure/altitude target value register (address 16h, 17h)

Altitude or pressure target value.

Depending on the setting of the ALT bit in the CTRL_REG1 register, it operates in either altimeter or barometer mode. This value works in conjunction with the window value (P_WND_MSB and P_WND_LSB). In altitude mode, the register value is 16-bit signed integer in meters.

In pressure mode, the value is a 16-bit unsigned value in two Pa units.

Table 36. P_TGT_MSB, P_TGT_LSB - pressure/altitude target value register (address 16h, 17h) bit allocation

| Location | | Bit | | | | | | | |
|----------|-----------|-------------|-----|-----|-----|-----|-----|-----|-----|
| Address | Register | 7 | 6 | 5 | 4 | 3 | 2 | 1 | 0 |
| 16h | P_TGT_MSB | P_TGT[15:8] | | | | | | | |
| 17h | P_TGT_LSB | P_TGT[7:0] | | | | | | | |
| Reset | | 0 | 0 | 0 | 0 | 0 | 0 | 0 | 0 |
| Access | | R/W | R/W | R/W | R/W | R/W | R/W | R/W | R/W |

14.15 T_TGT- temperature target value register (address 18h)

Temperature target value is input as an 8-bit signed integer in °C.

Table 37. T_TGT- temperature target value register (address 18h) bit allocation

| Bit | 7 | 6 | 5 | 4 | 3 | 2 | 1 | 0 |
|--------|------------|-----|-----|-----|-----|-----|-----|-----|
| Symbol | T_TGT[7:0] | | | | | | | |
| Reset | 0 | 0 | 0 | 0 | 0 | 0 | 0 | 0 |
| Access | R/W | R/W | R/W | R/W | R/W | R/W | R/W | R/W |

14.16 P_WND_LSB, P_WND_MSB - pressure/altitude window value register (address 19h, 1Ah)

Pressure or altitude window value register is arranged as an unsigned 16-bit integer of window value in meters or in two Pa units, depending on either altimeter or barometer mode.

Table 38. P_WND_LSB, P_WND_MSB - pressure/altitude window value register (address 19h, 1Ah) bit allocation

| Location | | Bit | | | | | | | |
|----------|-----------|-----------|-----|-----|-----|-----|-----|-----|-----|
| Address | Register | 7 | 6 | 5 | 4 | 3 | 2 | 1 | 0 |
| 19h | P_WND_LSB | P_W[15:8] | | | | | | | |
| 1Ah | P_WND_MSB | P_W[7:0] | | | | | | | |
| Reset | | 0 | 0 | 0 | 0 | 0 | 0 | 0 | 0 |
| Access | | R/W | R/W | R/W | R/W | R/W | R/W | R/W | R/W |

14.17 T_WIN- temperature window value register (address 1Bh)

The temperature alarm window value register is an unsigned 8-bit value in °C.

Table 39. T_WIN- temperature window value register (address 1Bh) bit allocation

| Bit | 7 | 6 | 5 | 4 | 3 | 2 | 1 | 0 |
|--------|------------|-----|-----|-----|-----|-----|-----|-----|
| Symbol | T_WIN[7:0] | | | | | | | |
| Reset | 0 | 0 | 0 | 0 | 0 | 0 | 0 | 0 |
| Access | R/W | R/W | R/W | R/W | R/W | R/W | R/W | R/W |

14.18 P_MIN_MSB, P_MIN_CSB, P_MIN_LSB - minimum pressure or altitude register (address 1Ch, 1Dh, 1Eh)

Register with captured minimum pressure or altitude value.

The altitude data is arranged as a 20-bit signed integer in meters. The first 16 bits are located in P_MIN_MSB and P_MIN_CSB. Fractions of a meter are stored in four bits in position 7 to 4 of P_MIN_LSB.

The pressure is arranged as a 20-bit unsigned data in Pascals. The first 18 bits are located in P_MIN_MSB, P_MIN_CSB and bits 7 to 6 of P_MIN_LSB. The two bits in position 5 to 4 of P_MIN_LSB represent the fractional component.

The register is cleared on power-up or manually by writing '0' to the register.

Table 40. P_MIN_MSB, P_MIN_CSB, P_MIN_LSB - minimum pressure or altitude register (address 1Ch, 1Dh, 1Eh) bit allocation

| Location | | Bit | | | | | | | |
|------------|-----------|--------------|-----|-----|-----|----------|-----|-----|-----|
| Address | Register | 7 | 6 | 5 | 4 | 3 | 2 | 1 | 0 |
| 1Ch | P_MIN_MSB | P_MIN[19:12] | | | | | | | |
| 1Dh | P_MIN_CSB | P_MIN[11:4] | | | | | | | |
| 1Eh | P_MIN_LSB | P_MIN[3:0] | | | | reserved | | | |
| Reset | | 0 | 0 | 0 | 0 | 0 | 0 | 0 | 0 |
| Access MSB | | R/W | R/W | R/W | R/W | R/W | R/W | R/W | R/W |
| Access CSB | | R/W | R/W | R/W | R/W | R/W | R/W | R/W | R/W |
| Access LSB | | R/W | R/W | R/W | R/W | R | R | R | R |

14.19 P_MAX_MSB, P_MAX_CSB, P_MAX_LSB - maximum pressure or altitude register (address 21h, 22h, 23h)

Register with captured maximum pressure or altitude value.

The altitude data is arranged as a 20-bit signed integer in meters. The first 16 bits are located in P_MAX_MSB and P_MAX_CSB. Fractions of a meter stored in four bits in position 7 to 4 of P_MAX_LSB.

The pressure is arranged as a 20-bit unsigned data in Pascals. The first 18 bits are located in P_MAX_MSB, P_MAX_CSB and bits 7 to 6 of P_MAX_LSB. The two bits in position 5 to 4 of P_MAX_LSB represent the fractional component.

The register is cleared on power-up or manually by writing '0' to the registers.

Table 41. P_MAX_MSB, P_MAX_CSB, P_MAX_LSB - maximum pressure or altitude register (address 21h, 22h, 23h) bit allocation

| Location | | Bit | | | | | | | |
|------------|-----------|--------------|-----|-----|-----|----------|-----|-----|-----|
| Address | Register | 7 | 6 | 5 | 4 | 3 | 2 | 1 | 0 |
| 21h | P_MAX_MSB | P_MAX[19:12] | | | | | | | |
| 22h | P_MAX_CSB | P_MAX[11:4] | | | | | | | |
| 23h | P_MAX_LSB | P_MAX[3:0] | | | | reserved | | | |
| Reset | | 0 | 0 | 0 | 0 | 0 | 0 | 0 | 0 |
| Access MSB | | R/W | R/W | R/W | R/W | R/W | R/W | R/W | R/W |
| Access CSB | | R/W | R/W | R/W | R/W | R/W | R/W | R/W | R/W |
| Access LSB | | R/W | R/W | R/W | R/W | R | R | R | R |

14.20 T_MIN_MSB, T_MIN_LSB - minimum temperature register (address 1Fh, 20h)

Register with captured minimum temperature value.

The temperature data is arranged as a 12-bit signed integer in °C. The first eight bits are located in T_MIN_MSB with fractions of a degree stored in four bits in position 7 to 4 of T_MIN_LSB.

The register is cleared on power-up or manually by writing '0' to the registers.

Table 42. T_MIN_MSB, T_MIN_LSB - minimum temperature register (address 1Fh, 20h) bit allocation

| Location | | Bit | | | | | | | |
|------------|-----------|-------------|-----|-----|-----|----------|-----|-----|-----|
| Address | Register | 7 | 6 | 5 | 4 | 3 | 2 | 1 | 0 |
| 1Fh | T_MIN_MSB | T_MIN[11:4] | | | | | | | |
| 20h | T_MIN_LSB | T_MIN[3:0] | | | | reserved | | | |
| Reset | | 0 | 0 | 0 | 0 | 0 | 0 | 0 | 0 |
| Access MSB | | R/W | R/W | R/W | R/W | R/W | R/W | R/W | R/W |
| Access LSB | | R/W | R/W | R/W | R/W | R | R | R | R |

14.21 T_MAX_MSB, T_MAX_LSB - maximum temperature register (address 24h, 25h)

Register with captured maximum temperature value.

The temperature data is arranged as a 12-bit signed integer in °C. The first eight bits are located in T_MAX_MSB with fractions of a degree stored in four bits in position 7 to 4 of T_MAX_LSB.

The register is cleared on power-up or manually by writing '0' to the registers

Table 43. T_MAX_MSB, T_MAX_LSB - minimum temperature register (address 24h, 25h) bit allocation

| Location | | Bit | | | | | | | |
|------------|-----------|-------------|-----|-----|-----|----------|-----|-----|-----|
| Address | Register | 7 | 6 | 5 | 4 | 3 | 2 | 1 | 0 |
| 24h | T_MAX_MSB | T_MAX[11:4] | | | | | | | |
| 25h | T_MAX_LSB | T_MAX[3:0] | | | | reserved | | | |
| Reset | | 0 | 0 | 0 | 0 | 0 | 0 | 0 | 0 |
| Access MSB | | R/W | R/W | R/W | R/W | R/W | R/W | R/W | R/W |
| Access LSB | | R/W | R/W | R/W | R/W | R | R | R | R |

14.22 Control registers

14.22.1 CTRL_REG1 - control register 1 (address 26h)

Note: Except for STANDBY and OST mode selection, the device must be in STANDBY mode to change any of the fields within bits 7 to 0 of CTRL_REG1 (26h).

Table 44. CTRL_REG1 - control register 1 (address 26h) bit allocation

| Bit | 7 | 6 | 5 | 4 | 3 | 2 | 1 | 0 |
|--------|-----|----------|---------|-----|-----|------------------|-----|------|
| Symbol | ALT | Reserved | OS[2:0] | | | 0 (R) RST (W) | OST | SBYB |
| Reset | 0 | 0 | 0 | 0 | 0 | 0 | 0 | 0 |
| Access | R/W | R | R/W | R/W | R/W | R/W | R/W | R/W |

Table 45. CTRL_REG1 - control register 1 (address 26h) bit description

| Bit | Symbol | Description |
|--------|------------------|--|
| 7 | ALT | Altimeter/barometer mode. 0 — Part is in barometer mode (reset value) 1 — Part is in altimeter mode |
| 6 | Reserved | |
| 5 to 3 | OS[2:0] | Oversample ratio. These bits select the oversampling ratio. Value is 2 ^{OS} . The default value is 000 for a ratio of 1. |
| 2 | 0 (R) RST (W) | Software reset. This bit is used to activate the software reset. The boot mechanism can be enabled in STANDBY and ACTIVE mode. When the boot bit is enabled the boot mechanism resets all functional block registers and loads the respective internal registers with default values. If the system was already in STANDBY mode, the reboot process will immediately begin, or else if the system was in ACTIVE mode, the boot mechanism will automatically transition the system from ACTIVE mode to STANDBY mode. Only then can the reboot process begin. The I ² C communication system is reset to avoid accidental corrupted data access. At the end of the boot process the RST bit is de-asserted to 0. Reading this bit will return a value of zero. 0 — Device reset disabled (reset value) 1 — Device reset enabled |
| 1 | OST | OST bit will initiate a measurement immediately. If the SBYB bit is set to active, setting the OST bit will initiate an immediate measurement, the part will then return to acquiring data as per the setting of the ST bits in CTRL_REG2. In this mode, the OST bit does not clear itself and must be cleared and set again to initiate another immediate measurement. In one-shot mode, when SBYB is 0, the OST bit is an auto-clear bit. When OST is set, the device initiates a measurement by going into active mode. Once a pressure/altitude and temperature measurement is completed, it clears the OST bit and comes back to STANDBY mode. User shall read the value of the OST bit before writing to this bit again. |
| 0 | SBYB | This bit is sets the mode to ACTIVE, where the system will make measurements at periodic times based on the value of ST bits. 0 — Part is in STANDBY mode (reset value) 1 — Part is ACTIVE |

Table 46. System output sample rate selection

| OS2 | OS1 | OS0 | Oversample ratio | Minimum time between data samples |
|-----|-----|-----|------------------|-----------------------------------|
| 0 | 0 | 0 | 1 | 6 ms |
| 0 | 0 | 1 | 2 | 10 ms |
| 0 | 1 | 0 | 4 | 18 ms |
| 0 | 1 | 1 | 8 | 34 ms |
| 1 | 0 | 0 | 16 | 66 ms |
| 1 | 0 | 1 | 32 | 130 ms |
| 1 | 1 | 0 | 64 | 258 ms |
| 1 | 1 | 1 | 128 | 512 ms |

14.22.2 CTRL_REG2 - control register 2 (address 27h)

Table 47. CTRL_REG2 - control register 2 (address 27h) bit allocation

| Bit | 7 | 6 | 5 | 4 | 3 | 2 | 1 | 0 |
|--------|----------|---|-------------|-----------|---------|-----|-----|-----|
| Symbol | reserved | | LOAD_OUTPUT | ALARM_SEL | ST[3:0] | | | |
| Reset | 0 | 0 | 0 | 0 | 0 | 0 | 0 | 0 |
| Access | R | R | R/W | R/W | R/W | R/W | R/W | R/W |

Table 48. CTRL_REG2 - control register 2 (address 27h) bit description

| Bit | Symbol | Description |
|--------|-------------|--|
| 7 to 6 | reserved | These bits are reserved. |
| 5 | LOAD_OUTPUT | This is to load the target values for SRC_PW/SRC_TW and SRC_PTH/SRC_TTH. 0 — Do not load OUT_P/OUT_T as target values (reset value) 1 — The next values of OUT_P/OUT_T are used to set the target values for the interrupts. Notes: <ul style="list-style-type: none"> • This bit must be set at least once if ALARM_SEL=1 • To reload the next OUT_P/OUT_T as the target values, clear and set again. |
| 4 | ALARM_SEL | The bit selects the target value for SRC_PW/SRC_TW and SRC_PTH/SRC_TTH. 0 — (reset value) The values in P_TGT_MSB, P_TGT_LSB and T_TGT are used. 1 — The values in OUT_P/OUT_T are used for calculating the interrupts SRC_PW/SRC_TW and SRC_PTH/SRC_TTH. |
| 3 to 0 | ST[3:0] | Auto acquisition time step. 0 — (reset value) Step value is 2ST — Giving a range of 1 second to 215 seconds (9 hours) |

14.22.3 CTRL_REG3 - interrupt CTRL register (address 28h)

Table 49. CTRL_REG3 - interrupt CTRL register (address 28h) bit allocation

| Bit | 7 | 6 | 5 | 4 | 3 | 2 | 1 | 0 |
|--------|----------|---|-------|--------|----------|---|-------|--------|
| Symbol | reserved | | IPOL1 | PP_OD1 | reserved | | IPOL2 | PP_OD2 |
| Reset | 0 | 0 | 0 | 0 | 0 | 0 | 0 | 0 |
| Access | R | R | R/W | R/W | R | R | R/W | R/W |

Table 50. CTRL_REG3 - interrupt CTRL register (address 28h) bit description

| Bit | Symbol | Description |
|--------|----------|---|
| 7 to 6 | reserved | These bits are reserved. |
| 5 | IPOL1 | The IPOL bit selects the polarity of the interrupt signal. When IPOL is '0' (default value) any interrupt event will signalled with a logical '0'. Interrupt Polarity active high, or active low on interrupt pad INT1. 0 — Active low (reset value) 1 — Active high |
| 4 | PP_OD1 | This bit configures the interrupt pin to push-pull or in open drain mode. The default value is 0 which corresponds to push-pull mode. The open drain configuration can be used for connecting multiple interrupt signals on the same interrupt line. push-pull/open drain selection on interrupt pad INT1. 0 — Internal pullup (reset value) 1 — Open drain |
| 3 to 2 | reserved | These bits are reserved. |
| 1 | PP_OD2 | Interrupt polarity active high, or active low on interrupt pad INT2. 0 — Active low (reset value) 1 — Active high |
| 0 | PP_OD2 | Push-pull/open drain selection on interrupt pad INT2. 0 — Internal pullup (reset value) 1 — Open drain |

14.22.4 CTRL_REG4 - interrupt enable register (address 29h)

The corresponding functional block interrupt enable bit allows the functional block to route its event detection flags to the system's interrupt controller. The interrupt controller routes the enabled functional block interrupt to the INT1 or INT2 pin.

Table 51. CTRL_REG4 - interrupt enable register (address 29h) bit allocation

| Bit | 7 | 6 | 5 | 4 | 3 | 2 | 1 | 0 |
|--------|-------------|-------------|-----------|-----------|------------|------------|-------------|-------------|
| Symbol | INT_EN_DRDY | INT_EN_FIFO | INT_EN_PW | INT_EN_TW | INT_EN_PTH | INT_EN_TTH | INT_EN_PCHG | INT_EN_TCHG |
| Reset | 0 | 0 | 0 | 0 | 0 | 0 | 0 | 0 |
| Access | R/W | R/W | R/W | R/W | R/W | R/W | R/W | R/W |

Table 52. CTRL_REG4 - interrupt enable register (address 29h) bit description

| Bit | Symbol | Description |
|-----|-------------|--|
| 7 | INT_EN_DRDY | Interrupt enable. 0 — Data ready interrupt disabled (reset value) 1 — Data ready interrupt enabled |
| 6 | INT_EN_FIFO | Interrupt enable. 0 — FIFO interrupt disabled (reset value) 1 — FIFO interrupt enabled |
| 5 | INT_EN_PW | Interrupt enable. 0 — Pressure window interrupt disabled (reset value) 1 — Pressure window interrupt enabled |
| 4 | INT_EN_TW | Interrupt enable. 0 — Temperature window interrupt disabled (reset value) 1 — Temperature window interrupt enabled |
| 3 | INT_EN_PTH | Interrupt enable. 0 — Pressure threshold interrupt disabled (reset value) 1 — Pressure threshold interrupt enabled |
| 2 | INT_EN_TTH | Interrupt enable. 0 — Temperature threshold interrupt disabled (reset value) 1 — Temperature threshold interrupt enabled |
| 1 | INT_EN_PCHG | Interrupt enable. 0 — Pressure change interrupt disabled (reset value) 1 — Pressure change interrupt enabled |
| 0 | INT_EN_TCHG | Interrupt enable. 0 — Temperature change interrupt disabled (reset value) 1 — Temperature change interrupt enabled |

14.22.5 CTRL_REG5 - interrupt configuration register (address 2Ah)

Table 53. CTRL_REG5 - interrupt configuration register (address 2Ah) bit allocation

| Bit | 7 | 6 | 5 | 4 | 3 | 2 | 1 | 0 |
|--------|--------------|--------------|------------|------------|-------------|-------------|--------------|--------------|
| Symbol | INT_CFG_DRDY | INT_CFG_FIFO | INT_CFG_PW | INT_CFG_TW | INT_CFG_PTH | INT_CFG_TTH | INT_CFG_PCHG | INT_CFG_TCHG |
| Reset | 0 | 0 | 0 | 0 | 0 | 0 | 0 | 0 |
| Access | R/W | R/W | R/W | R/W | R/W | R/W | R/W | R/W |

Table 54. CTRL_REG5 - interrupt configuration register (address 2Ah) bit description

| Bit | Symbol | Description |
|-----|--------------|--|
| 7 | INT_EN_DRDY | INT1/INT2 configuration. 0 — Interrupt is routed to INT2 pin (reset value) 1 — Interrupt is routed to INT1 |
| 6 | INT_CFG_FIFO | INT1/INT2 configuration. 0 — Interrupt is routed to INT2 pin (reset value) 1 — Interrupt is routed to INT1 |
| 5 | INT_CFG_PW | INT1/INT2 configuration. 0 — Interrupt is routed to INT2 pin (reset value) 1 — Interrupt is routed to INT1 |
| 4 | INT_CFG_TW | INT1/INT2 configuration. 0 — Interrupt is routed to INT2 pin (reset value) 1 — Interrupt is routed to INT1 |
| 3 | INT_CFG_PTH | INT1/INT2 configuration. 0 — Interrupt is routed to INT2 pin (reset value) 1 — Interrupt is routed to INT1 |
| 2 | INT_CFG_TTH | INT1/INT2 configuration. 0 — Interrupt is routed to INT2 pin (reset value) 1 — Interrupt is routed to INT1 |
| 1 | INT_CFG_PCHG | INT1/INT2 configuration. 0 — Interrupt is routed to INT2 pin (reset value) 1 — Interrupt is routed to INT1 |
| 0 | INT_CFG_TCHG | INT1/INT2 configuration. 0 — Interrupt is routed to INT2 pin (reset value) 1 — Interrupt is routed to INT1 |

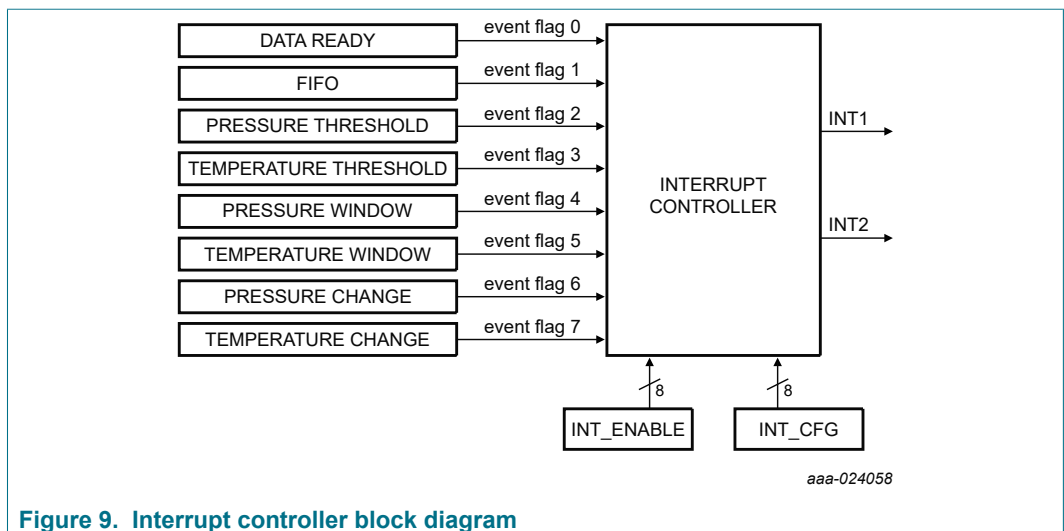
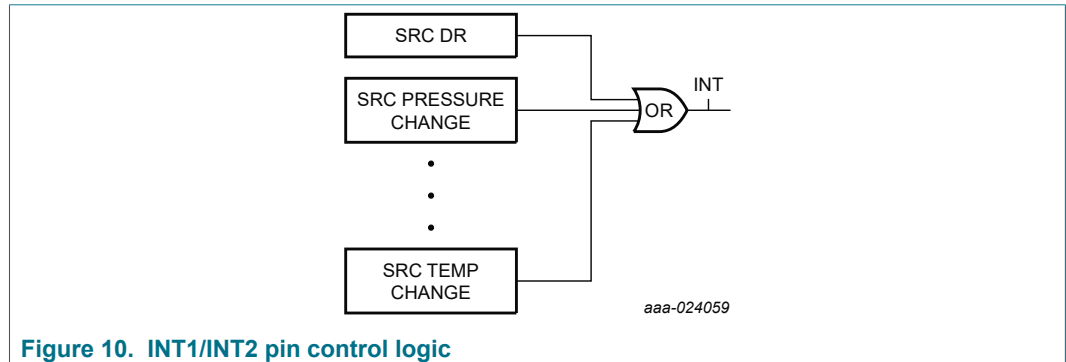

Figure 9. Interrupt controller block diagram

The system's interrupt controller uses the corresponding bit field in the CTRL_REG5 register to determine the routing table for the INT1 and INT2 interrupt pins. If the bit value is logic '0' the functional block's interrupt is routed to INT2, and if the bit value is logic '1' then the interrupt is routed to INT1.

All interrupts routed to INT1 or INT2 are logically OR'd as illustrated in [Figure 10](#). One or more functional blocks can assert an interrupt pin simultaneously, therefore a host application responding to an interrupt should read the INT_SOURCE register to determine the appropriate sources of the interrupt.



14.23 Offset correction registers

The 2's complement offset correction registers values are used to trim the temperature, altitude and pressure offsets that might occur over the life of the product.

14.23.1 OFF_P - offset pressure correction register (address 2Bh)

Pressure user accessible offset trim value expressed as an 8-bit, 2's complement number. The user offset registers may be adjusted to enhance accuracy and optimize the system performance. Range is from -512 to +508 Pa, 4 Pa/LSB.

Table 55. OFF_P - offset correction register (address 2Bh) bit allocation

| Bit | 7 | 6 | 5 | 4 | 3 | 2 | 1 | 0 |
|--------|------------|-----|-----|-----|-----|-----|-----|-----|
| Symbol | OFF_P[7:0] | | | | | | | |
| Reset | 0 | 0 | 0 | 0 | 0 | 0 | 0 | 0 |
| Access | R/W | R/W | R/W | R/W | R/W | R/W | R/W | R/W |

14.23.2 OFF_T - offset temperature correction register (address 2Ch)

Temperature user accessible offset trim value expressed as an 8-bit, 2's complement number. The user offset registers may be adjusted to enhance accuracy and optimize the system performance. Range is from -8 to +7.9375 °C, 0.0625 °C/LSB.

Table 56. OFF_T - offset temperature correction register (address 2Ch) bit allocation

| Bit | 7 | 6 | 5 | 4 | 3 | 2 | 1 | 0 |
|--------|------------|-----|-----|-----|-----|-----|-----|-----|
| Symbol | OFF_T[7:0] | | | | | | | |
| Reset | 0 | 0 | 0 | 0 | 0 | 0 | 0 | 0 |
| Access | R/W | R/W | R/W | R/W | R/W | R/W | R/W | R/W |

14.23.3 OFF_H - altitude data user offset register (address 2Dh)

Altitude data user offset register (OFF_H) is expressed as a 2's complement number in meters. See [Section 9.1.3 "Pressure/altitude"](#). The user offset register provides user adjustment to the vertical height of the altitude output. The range of values are from -128 to +127 meters.

Table 57. OFF_H - altitude data user offset register (address 2Dh) bit allocation

| Bit | 7 | 6 | 5 | 4 | 3 | 2 | 1 | 0 |
|--------|------------|-----|-----|-----|-----|-----|-----|-----|
| Symbol | OFF_H[7:0] | | | | | | | |
| Reset | 0 | 0 | 0 | 0 | 0 | 0 | 0 | 0 |
| Access | R/W | R/W | R/W | R/W | R/W | R/W | R/W | R/W |

15 Package information

15.1 Package dimensions

This drawing is located at http://nxp.com/files/shared/doc/package_info/98ASA00260D.pdf.

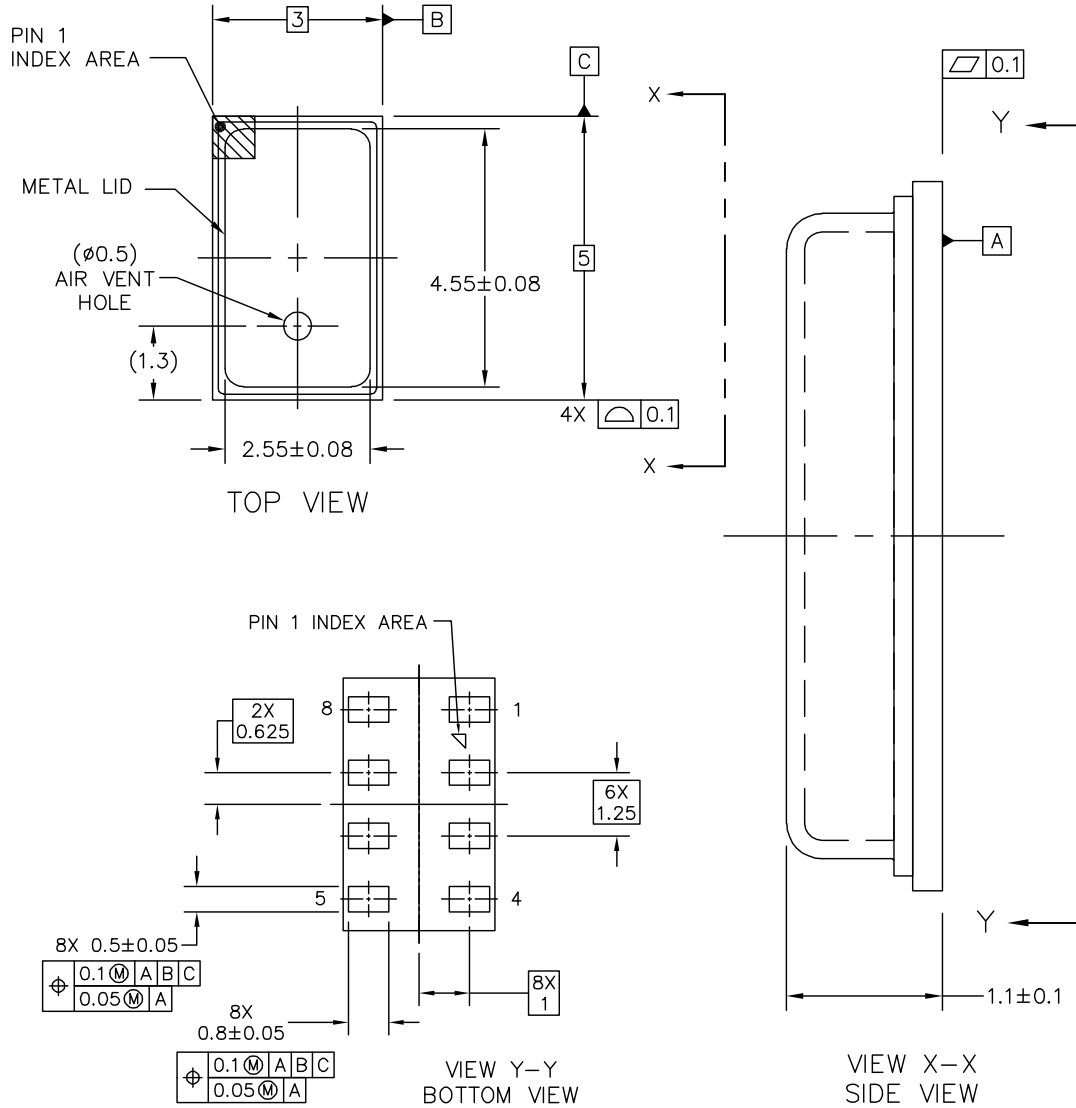

| | | |
|--|--------------------------|----------------------------|
| © NXP SEMICONDUCTORS N.V. ALL RIGHTS RESERVED | MECHANICAL OUTLINE | PRINT VERSION NOT TO SCALE |
| TITLE: LGA 8 I/O, 3 X 5 X 1.25 PITCH, SENSOR 1.2MAX MM PKG | DOCUMENT NO: 98ASA00260D | REV: A |
| | STANDARD: NON-JEDEC | |
| | SOT1768-1 | 07 JAN 2016 |



NOTES:

1. ALL DIMENSIONS IN MILLIMETERS.
2. DIMENSIONING AND TOLERANCING PER ASME Y14.5M-1994
3. STYLE:

| | |
|--------------|-------------|
| PIN 1: VDD | PIN 5: INT2 |
| PIN 2: CAP | PIN 6: INT1 |
| PIN 3: GND | PIN 7: SDA |
| PIN 4: VDDIO | PIN 8: SCL |

| | | |
|---|--------------------------|----------------------------|
| © NXP SEMICONDUCTORS N.V. ALL RIGHTS RESERVED | MECHANICAL OUTLINE | PRINT VERSION NOT TO SCALE |
| TITLE: LGA 8 I/O, 3 X 5 X 1.25 PITCH, SENSOR 1.2MAX MM PKG | DOCUMENT NO: 98ASA00260D | REV: A |
| | STANDARD: NON-JEDEC | |
| | SOT1768-1 | 07 JAN 2016 |

Figure 11. Case 98ASA00260D, LGA package

16 Soldering/landing pad information

The LGA package is compliant with the RoHS standard.

Note: Pin 1 index area marker does not have any internal electrical connections. Handling and soldering recommendations for pressure sensors are available in application notes AN1984 and AN3150.

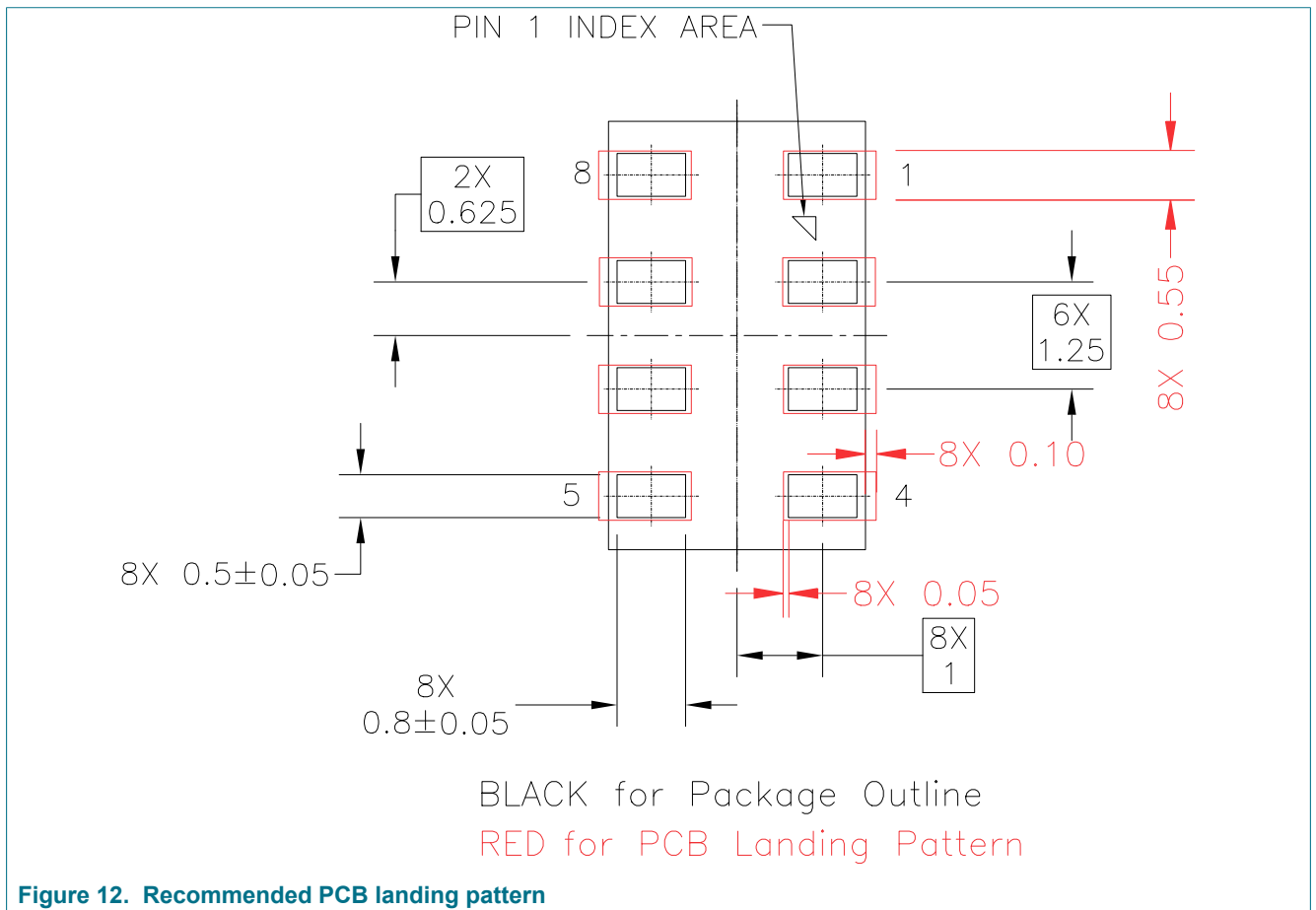

Figure 12. Recommended PCB landing pattern

17 Tape and reel specifications

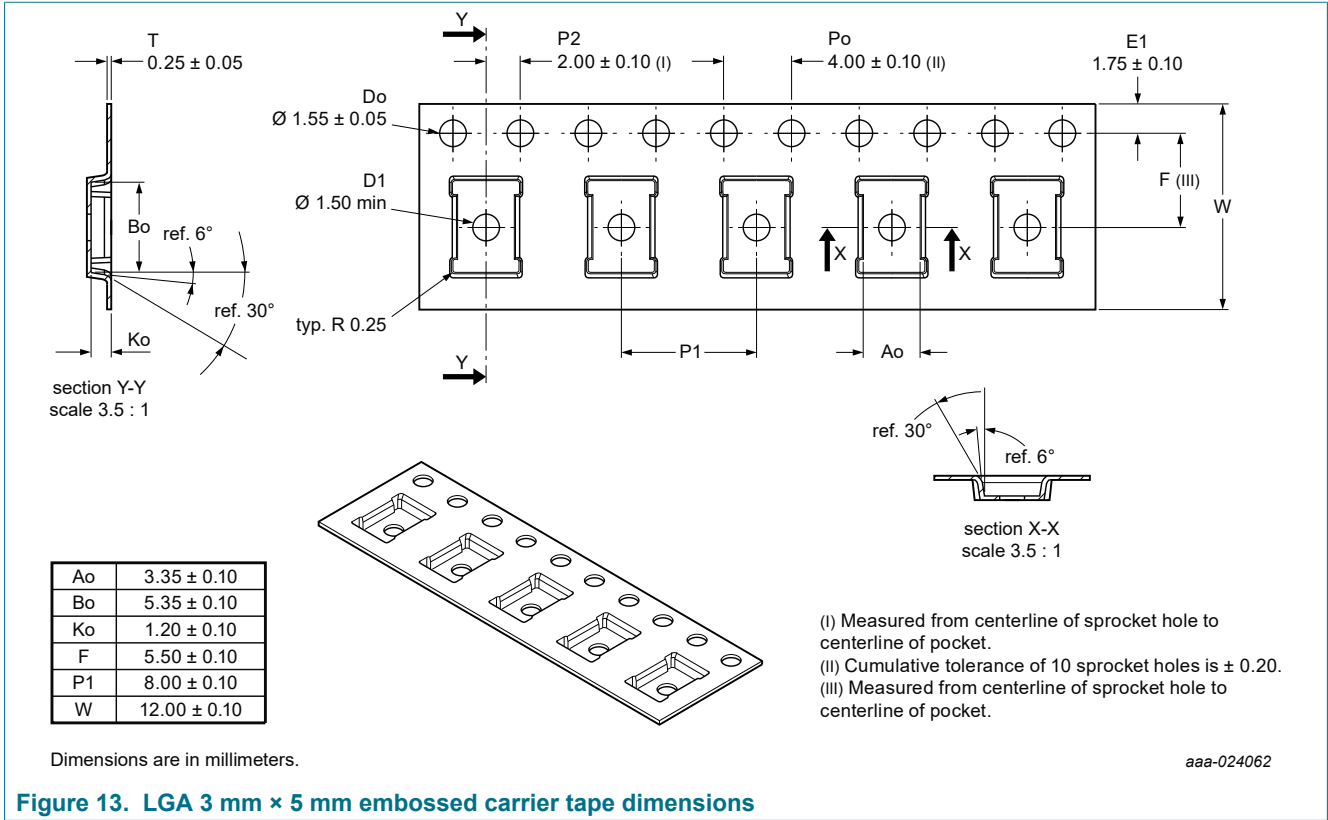

Figure 13. LGA 3 mm x 5 mm embossed carrier tape dimensions

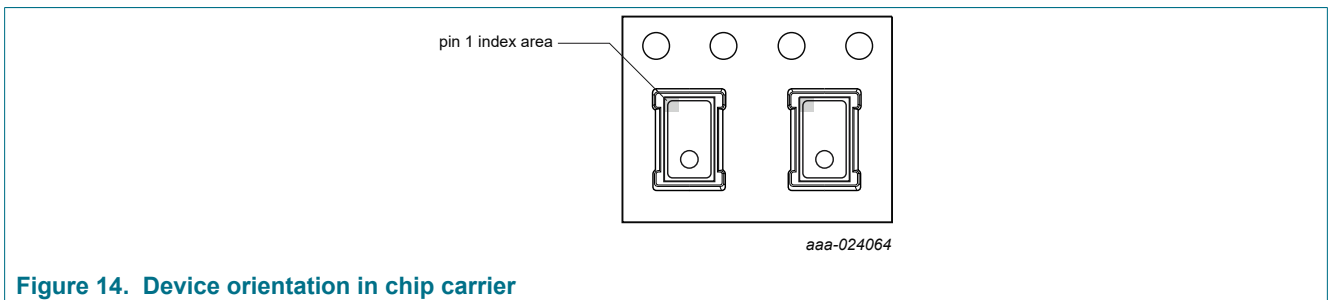

Figure 14. Device orientation in chip carrier

18 Related documentation

The device features and operations may be described in a variety of reference manuals, user guides, and application notes. To find the most-current versions of these documents:

- Go to the product page at nxp.com/MPL3115A2.
- Click on the **Documentation** tab.

19 Revision history

Table 58. Revision history

| Document ID | Release date | Data sheet status | Change notice | Supersedes |
|-----------------|---|----------------------|---------------|-----------------|
| MPL3115A2 v.8 | 20180412 | Technical data | n.a. | MPL3115A2 v.7 |
| Modifications | <ul style="list-style-type: none"> Updated the package image on the first page. Updated the image in Figure 1 in Section 5. Updated the image in Figure 2 in Section 6. Updated the image for Figure 3 in Section 7. Updated the images for Figure 4 and Figure 5 in Section 10.2. Updated the image in Figure 6 in Section 11. Updated the images in Figure 7 and Figure 8 in Section 12. Updated "altitude/pressure" to "pressure/altitude" in the first paragraph of Section 13.4. Revised the description for bit 2 from "Pressure/altitude new data available." to "New pressure/altitude data available." in Table 15 of Section 14.2. Revised the description for bit 1 from "Temperature new data available." to "New temperature data available." in Table 15 of Section 14.2. Revised Table 25 in Section 14.8.2 as follows: <ul style="list-style-type: none"> Added "(1 byte)" to the first five rows of the first column Added "158th read (1 byte)," "159th read (1 byte)," and "160th read (1 byte)" to the last three rows of the first column Updated the descriptions for bit 5 SRC_PWS and bit 3 SRC_PTH from "Altitude/pressure" to "Pressure/altitude" in Table 32 in Section 14.11. Updated the images in Figure 9 and Figure 10 in Section 14.22.5. Revised the title of Table 56 from "OFF_P..." to "OFF_T..." in Section 14.23.2. Updated the images in Figure 13 and Figure 14 in Section 17. | | | |
| MPL3115A2 v.7 | 20180215 | Technical data | n.a. | MPL3115A2 v.6 |
| MPL3115A2 v.6 | 20171009 | Technical data | n.a. | MPL3115A2 v.5.2 |
| MPL3115A2 v.5.2 | 20170405 | Technical data | n.a. | MPL3115A2 v.5.1 |
| MPL3115A2 v.5.1 | 20160913 | Technical data | n.a. | MPL3115A2 v.5.0 |
| MPL3115A2 v.5.0 | 20160816 | Technical data | n.a. | MPL3115A2 v.4.0 |
| MPL3115A2 v.4.0 | 2015 September | Technical data | n.a. | MPL3115A2 v.3.0 |
| MPL3115A2 v.3.0 | 2013 December | Advanced information | n.a. | MPL3115A2 v.2.2 |
| MPL3115A2 v.2.2 | 2012 July | Advanced information | n.a. | MPL3115A2 v.2.1 |
| MPL3115A2 v.2.1 | 2012 May | Advanced information | n.a. | MPL3115A2 v.2.0 |
| MPL3115A2 v.2.0 | 2012 April | Advanced information | n.a. | MPL3115A2 v.1.0 |
| MPL3115A2 v.1.0 | 2011 December | Product preview | n.a. | MPL3115A2 v.0 |
| MPL3115A2 v.0 | 2011 June | Product preview | n.a. | n.a. |

20 Legal information

20.1 Data sheet status

| Document status ^{[1][2]} | Product status ^[3] | Definition |
|---|-------------------------------|--|
| [short] Data sheet: product preview | Development | This document contains certain information on a product under development. NXP reserves the right to change or discontinue this product without notice. |
| [short] Data sheet: advance information | Qualification | This document contains information on a new product. Specifications and information herein are subject to change without notice. |
| [short] Data sheet: technical data | Production | This document contains the product specification. NXP Semiconductors reserves the right to change the detail specifications as may be required to permit improvements in the design of its products. |

[1] Please consult the most recently issued document before initiating or completing a design.

[2] The term 'short data sheet' is explained in section "Definitions".

[3] The product status of device(s) described in this document may have changed since this document was published and may differ in case of multiple devices. The latest product status information is available on the Internet at URL <http://www.nxp.com>.

20.2 Definitions

Draft — The document is a draft version only. The content is still under internal review and subject to formal approval, which may result in modifications or additions. NXP Semiconductors does not give any representations or warranties as to the accuracy or completeness of information included herein and shall have no liability for the consequences of use of such information.

Short data sheet — A short data sheet is an extract from a full data sheet with the same product type number(s) and title. A short data sheet is intended for quick reference only and should not be relied upon to contain detailed and full information. For detailed and full information see the relevant full data sheet, which is available on request via the local NXP Semiconductors sales office. In case of any inconsistency or conflict with the short data sheet, the full data sheet shall prevail.

Product specification — The information and data provided in a technical data data sheet shall define the specification of the product as agreed between NXP Semiconductors and its customer, unless NXP Semiconductors and customer have explicitly agreed otherwise in writing. In no event however, shall an agreement be valid in which the NXP Semiconductors product is deemed to offer functions and qualities beyond those described in the technical data data sheet.

20.3 Disclaimers

Limited warranty and liability — Information in this document is believed to be accurate and reliable. However, NXP Semiconductors does not give any representations or warranties, expressed or implied, as to the accuracy or completeness of such information and shall have no liability for the consequences of use of such information. NXP Semiconductors takes no responsibility for the content in this document if provided by an information source outside of NXP Semiconductors. In no event shall NXP Semiconductors be liable for any indirect, incidental, punitive, special or consequential damages (including - without limitation - lost profits, lost savings, business interruption, costs related to the removal or replacement of any products or rework charges) whether or not such damages are based on tort (including negligence), warranty, breach of contract or any other legal theory. Notwithstanding any damages that customer might incur for any reason whatsoever, NXP Semiconductors' aggregate and cumulative liability towards customer for the products described herein shall be limited in accordance with the Terms and conditions of commercial sale of NXP Semiconductors.

Right to make changes — NXP Semiconductors reserves the right to make changes to information published in this document, including without

limitation specifications and product descriptions, at any time and without notice. This document supersedes and replaces all information supplied prior to the publication hereof.

Suitability for use — NXP Semiconductors products are not designed, authorized or warranted to be suitable for use in life support, life-critical or safety-critical systems or equipment, nor in applications where failure or malfunction of an NXP Semiconductors product can reasonably be expected to result in personal injury, death or severe property or environmental damage. NXP Semiconductors and its suppliers accept no liability for inclusion and/or use of NXP Semiconductors products in such equipment or applications and therefore such inclusion and/or use is at the customer's own risk.

Applications — Applications that are described herein for any of these products are for illustrative purposes only. NXP Semiconductors makes no representation or warranty that such applications will be suitable for the specified use without further testing or modification. Customers are responsible for the design and operation of their applications and products using NXP Semiconductors products, and NXP Semiconductors accepts no liability for any assistance with applications or customer product design. It is customer's sole responsibility to determine whether the NXP Semiconductors product is suitable and fit for the customer's applications and products planned, as well as for the planned application and use of customer's third party customer(s). Customers should provide appropriate design and operating safeguards to minimize the risks associated with their applications and products. NXP Semiconductors does not accept any liability related to any default, damage, costs or problem which is based on any weakness or default in the customer's applications or products, or the application or use by customer's third party customer(s). Customer is responsible for doing all necessary testing for the customer's applications and products using NXP Semiconductors products in order to avoid a default of the applications and the products or of the application or use by customer's third party customer(s). NXP does not accept any liability in this respect.

Limiting values — Stress above one or more limiting values (as defined in the Absolute Maximum Ratings System of IEC 60134) will cause permanent damage to the device. Limiting values are stress ratings only and (proper) operation of the device at these or any other conditions above those given in the Recommended operating conditions section (if present) or the Characteristics sections of this document is not warranted. Constant or repeated exposure to limiting values will permanently and irreversibly affect the quality and reliability of the device.

Terms and conditions of commercial sale — NXP Semiconductors products are sold subject to the general terms and conditions of commercial sale, as published at <http://www.nxp.com/profile/terms>, unless otherwise agreed in a valid written individual agreement. In case an individual agreement is concluded only the terms and conditions of the respective agreement shall apply. NXP Semiconductors hereby expressly objects to

applying the customer's general terms and conditions with regard to the purchase of NXP Semiconductors products by customer.

No offer to sell or license — Nothing in this document may be interpreted or construed as an offer to sell products that is open for acceptance or the grant, conveyance or implication of any license under any copyrights, patents or other industrial or intellectual property rights.

Export control — This document as well as the item(s) described herein may be subject to export control regulations. Export might require a prior authorization from competent authorities.

Non-automotive qualified products — Unless this data sheet expressly states that this specific NXP Semiconductors product is automotive qualified, the product is not suitable for automotive use. It is neither qualified nor tested in accordance with automotive testing or application requirements. NXP Semiconductors accepts no liability for inclusion and/or use of non-automotive qualified products in automotive equipment or applications. In the event that customer uses the product for design-in and use in automotive

applications to automotive specifications and standards, customer (a) shall use the product without NXP Semiconductors' warranty of the product for such automotive applications, use and specifications, and (b) whenever customer uses the product for automotive applications beyond NXP Semiconductors' specifications such use shall be solely at customer's own risk, and (c) customer fully indemnifies NXP Semiconductors for any liability, damages or failed product claims resulting from customer design and use of the product for automotive applications beyond NXP Semiconductors' standard warranty and NXP Semiconductors' product specifications.

Translations — A non-English (translated) version of a document is for reference only. The English version shall prevail in case of any discrepancy between the translated and English versions.

20.4 Trademarks

Notice: All referenced brands, product names, service names and trademarks are the property of their respective owners.

Tables

| | | | | | |
|----------|---|----|----------|--|----|
| Tab. 1. | Ordering information | 2 | Tab. 31. | INT_SOURCE - system interrupt status register (address 12h) bit allocation | 29 |
| Tab. 2. | Pin description | 3 | Tab. 32. | INT_SOURCE - system interrupt status register (address 12h) bit description | 29 |
| Tab. 3. | Maximum ratings | 7 | Tab. 33. | PT_DATA_CFG - sensor data register (address13h) bit allocation | 30 |
| Tab. 4. | ESD and latchup protection characteristics | 7 | Tab. 34. | PT_DATA_CFG - sensor data register (address13h) bit description | 30 |
| Tab. 5. | Mechanical characteristics | 8 | Tab. 35. | BAR_IN_MSB, BAR_IN_LSB - barometric pressure input register (address 14h, 15h) bit allocation | 31 |
| Tab. 6. | Electrical characteristics | 9 | Tab. 36. | P_TGT_MSB, P_TGT_LSB - pressure/altitude target value register (address 16h, 17h) bit allocation | 31 |
| Tab. 7. | Serial interface pin descriptions | 10 | Tab. 37. | T_TGT- temperature target value register (address 18h) bit allocation | 32 |
| Tab. 8. | I2C Slave timing values | 10 | Tab. 38. | P_WND_LSB, P_WND_MSB - pressure/altitude window value register (address 19h, 1Ah) bit allocation | 32 |
| Tab. 9. | Mode of operation description | 12 | Tab. 39. | T_WIN- temperature window value register (address 1Bh) bit allocation | 32 |
| Tab. 10. | Register address map | 19 | Tab. 40. | P_MIN_MSB, P_MIN_CSB, P_MIN_LSB - minimum pressure or altitude register (address 1Ch, 1Dh, 1Eh) bit allocation | 33 |
| Tab. 11. | Register address map: Area A (F_Mode = 0, FIFO disabled) | 20 | Tab. 41. | P_MAX_MSB, P_MAX_CSB, P_MAX_LSB - maximum pressure or altitude register (address 21h, 22h, 23h) bit allocation | 33 |
| Tab. 12. | Register address map: Area A (F_Mode > 0, FIFO in circular buffer or full stop mode) | 21 | Tab. 42. | T_MIN_MSB, T_MIN_LSB - minimum temperature register (address 1Fh, 20h) bit allocation | 34 |
| Tab. 13. | Alias for DR_Status (06h) or F_Status (0Dh) registers | 21 | Tab. 43. | T_MAX_MSB, T_MAX_LSB - minimum temperature register (address 24h, 25h) bit allocation | 34 |
| Tab. 14. | DR_STATUS - status register (address 06h) bit allocation | 21 | Tab. 44. | CTRL_REG1 - control register 1 (address 26h) bit allocation | 34 |
| Tab. 15. | DR_STATUS - status register (address 06h) bit description | 22 | Tab. 45. | CTRL_REG1 - control register 1 (address 26h) bit description | 35 |
| Tab. 16. | OUT_P_MSB, OUT_P_CSB, OUT_P_LSB - pressure and altitude data registers (address 01h, 02h, 03h) bit allocation | 23 | Tab. 46. | System output sample rate selection | 35 |
| Tab. 17. | OUT_T_MSB, OUT_T_LSB - temperature data registers (address 04h, 05h) bit allocation | 24 | Tab. 47. | CTRL_REG2 - control register 2 (address 27h) bit allocation | 36 |
| Tab. 18. | OUT_P_DELTA_MSB, OUT_P_DELTA_CSB, OUT_P_DELTA_LSB - pressure and altitude delta register (address 07h, 08h, 09h) bit allocation | 24 | Tab. 48. | CTRL_REG2 - control register 2 (address 27h) bit description | 36 |
| Tab. 19. | OUT_T_DELTA_MSB, OUT_T_DELTA_LSB - temperature delta register (address 0Ah, 0Bh) bit allocation | 25 | Tab. 49. | CTRL_REG3 - interrupt CTRL register (address 28h) bit allocation | 36 |
| Tab. 20. | WHO_AM_I - device ID register (address 0Ch) bit allocation | 25 | Tab. 50. | CTRL_REG3 - interrupt CTRL register (address 28h) bit description | 37 |
| Tab. 21. | F_STATUS - FIFO status register (address 0Dh) bit allocation | 25 | Tab. 51. | CTRL_REG4 - interrupt enable register (address 29h) bit allocation | 37 |
| Tab. 22. | F_STATUS - FIFO status register (address 0Dh) bit description | 26 | Tab. 52. | CTRL_REG4 - interrupt enable register (address 29h) bit description | 38 |
| Tab. 23. | F_STATUS - FIFO status register (address 0Dh) bit description | 26 | Tab. 53. | CTRL_REG5 - interrupt configuration register (address 2Ah) bit allocation | 38 |
| Tab. 24. | F_DATA - FIFO data register (address 0Eh) bit allocation | 26 | Tab. 54. | CTRL_REG5 - interrupt configuration register (address 2Ah) bit description | 39 |
| Tab. 25. | Read accesses through F_DATA | 27 | Tab. 55. | OFF_P - offset correction register (address 2Bh) bit allocation | 40 |
| Tab. 26. | F_SETUP- FIFO setup register (address 0Fh) bit allocation | 27 | | | |
| Tab. 27. | F_SETUP- FIFO setup register (address 0Fh) bit description | 28 | | | |
| Tab. 28. | TIME_DLY - time delay register (address 10h) bit allocation | 28 | | | |
| Tab. 29. | SYSMOD - system mode register (address 11h) bit allocation | 28 | | | |
| Tab. 30. | SYSMOD - system mode register (address 11h) bit description | 29 | | | |

Tab. 56. OFF_T - offset temperature correction register (address 2Ch) bit allocation40

Tab. 57. OFF_H - altitude data user offset register (address 2Dh) bit allocation 41

Tab. 58. Revision history46

Figures

Fig. 1. Block diagram 2
 Fig. 2. 8-pin LGA pinout 3
 Fig. 3. Typical application diagram4
 Fig. 4. I2C slave timing diagram 11
 Fig. 5. I2C bus transmission signals 12
 Fig. 6. Mode transition diagram2
 Fig. 7. Polling - no FIFO 14
 Fig. 8. Interrupt - no FIFO 15

Fig. 9. Interrupt controller block diagram39
 Fig. 10. INT1/INT2 pin control logic40
 Fig. 11. Case 98ASA00260D, LGA package 42
 Fig. 12. Recommended PCB landing pattern 44
 Fig. 13. LGA 3 mm × 5 mm embossed carrier tape dimensions 45
 Fig. 14. Device orientation in chip carrier45

Contents

| | | | | | |
|-----------|--|-----------|--------|--|----|
| 1 | General description | 1 | 14.1 | STATUS - sensor status register (address 00h) | 21 |
| 2 | Features and benefits | 1 | 14.2 | DR_STATUS - status register (address 06h) ... | 21 |
| 3 | Applications | 2 | 14.2.1 | Data registers with F_MODE = 00 (FIFO disabled) | 22 |
| 4 | Ordering information | 2 | 14.3 | OUT_P_MSB, OUT_P_CSB, OUT_P_LSB - pressure and altitude data registers (address 01h, 02h, 03h) | 23 |
| 5 | Block diagram | 2 | 14.3.1 | Data registers with F_MODE = 00 | 23 |
| 6 | Pinning information | 3 | 14.4 | OUT_T_MSB, OUT_T_LSB - temperature data registers (address 04h, 05h) | 23 |
| 6.1 | Pinning | 3 | 14.5 | OUT_P_DELTA_MSB, OUT_P_DELTA_CSB, OUT_P_DELTA_LSB - pressure and altitude delta register (address 07h, 08h, 09h) | 24 |
| 6.2 | Pin description | 3 | 14.6 | OUT_T_DELTA_MSB, OUT_T_DELTA_LSB - temperature delta register (address 0Ah, 0Bh) | 24 |
| 7 | System connections | 4 | 14.7 | WHO_AM_I - device ID register (address 0Ch) | 25 |
| 8 | Handling and board mount recommendations | 4 | 14.8 | FIFO setup registers | 25 |
| 8.1 | Methods of handling | 4 | 14.8.1 | F_STATUS - FIFO status register (address 0Dh) | 25 |
| 8.2 | Board mount recommendations | 5 | 14.8.2 | F_DATA - FIFO data register (address 0Eh) ... | 26 |
| 9 | Mechanical and electrical specifications | 5 | 14.8.3 | F_SETUP- FIFO setup register (address 0Fh) | 27 |
| 9.1 | Terminology | 5 | 14.9 | TIME_DLY - time delay register (address 10h) | 28 |
| 9.1.1 | Resolution | 5 | 14.10 | SYSMOD - system mode register (address 11h) | 28 |
| 9.1.2 | Accuracy | 5 | 14.11 | INT_SOURCE - system interrupt status register (address 12h) | 29 |
| 9.1.2.1 | Offset | 5 | 14.12 | PT_DATA_CFG - sensor data register (address 13h) | 30 |
| 9.1.2.2 | Linearity | 6 | 14.13 | BAR_IN_MSB, BAR_IN_LSB - barometric pressure input register (address 14h, 15h) | 31 |
| 9.1.2.3 | Absolute pressure | 6 | 14.14 | P_TGT_MSB, P_TGT_LSB - pressure/altitude target value register (address 16h, 17h) | 31 |
| 9.1.2.4 | Span | 6 | 14.15 | T_TGT- temperature target value register (address 18h) | 31 |
| 9.1.3 | Pressure/altitude | 6 | 14.16 | P_WND_LSB, P_WND_MSB - pressure/altitude window value register (address 19h, 1Ah) | 32 |
| 9.2 | Absolute maximum ratings | 7 | 14.17 | T_WIN- temperature window value register (address 1Bh) | 32 |
| 9.3 | Mechanical characteristics | 8 | 14.18 | P_MIN_MSB, P_MIN_CSB, P_MIN_LSB - minimum pressure or altitude register (address 1Ch, 1Dh, 1Eh) | 32 |
| 9.4 | Electrical characteristics | 9 | 14.19 | P_MAX_MSB, P_MAX_CSB, P_MAX_LSB - maximum pressure or altitude register (address 21h, 22h, 23h) | 33 |
| 10 | Digital interface | 10 | 14.20 | T_MIN_MSB, T_MIN_LSB - minimum temperature register (address 1Fh, 20h) | 33 |
| 10.1 | I2C characteristics | 10 | 14.21 | T_MAX_MSB, T_MAX_LSB - maximum temperature register (address 24h, 25h) | 34 |
| 10.2 | I2C operation | 11 | | | |
| 11 | Modes of operation | 12 | | | |
| 11.1 | OFF | 13 | | | |
| 11.2 | STANDBY | 13 | | | |
| 11.3 | ACTIVE | 13 | | | |
| 12 | Quick start setup | 13 | | | |
| 13 | Functionality | 15 | | | |
| 13.1 | Factory calibration | 16 | | | |
| 13.2 | Barometer/altimeter function | 16 | | | |
| 13.2.1 | Barometric input | 16 | | | |
| 13.3 | Temperature function | 16 | | | |
| 13.4 | Autonomous data acquisition | 17 | | | |
| 13.5 | FIFO | 17 | | | |
| 13.6 | External interrupts | 17 | | | |
| 13.6.1 | Reach target threshold pressure/altitude (SRC_PTH) | 17 | | | |
| 13.6.2 | Reach window target pressure/altitude (SRC_PW) | 17 | | | |
| 13.6.3 | Reach target threshold temperature (SRC_TTH) | 18 | | | |
| 13.6.4 | Reach window target temperature (SRC_TW) | 18 | | | |
| 13.6.5 | Pressure/altitude change (SRC_PCHG) | 18 | | | |
| 13.6.6 | Temperature change (SRC_TCHG) | 18 | | | |
| 13.6.7 | Data ready | 18 | | | |
| 13.6.8 | FIFO event | 18 | | | |
| 13.6.9 | Pressure/altitude and temperature delta | 18 | | | |
| 13.6.10 | Min/max data value storage | 18 | | | |
| 14 | Register descriptions | 19 | | | |

14.22 Control registers 34

14.22.1 CTRL_REG1 - control register 1 (address 26h)34

14.22.2 CTRL_REG2 - control register 2 (address 27h)36

14.22.3 CTRL_REG3 - interrupt CTRL register (address 28h) 36

14.22.4 CTRL_REG4 - interrupt enable register (address 29h) 37

14.22.5 CTRL_REG5 - interrupt configuration register (address 2Ah)38

14.23 Offset correction registers 40

14.23.1 OFF_P - offset pressure correction register (address 2Bh)40

14.23.2 OFF_T - offset temperature correction register (address 2Ch)40

14.23.3 OFF_H - altitude data user offset register (address 2Dh)41

15 Package information41

15.1 Package dimensions41

16 Soldering/landing pad information43

17 Tape and reel specifications45

18 Related documentation 45

19 Revision history46

20 Legal information47

Please be aware that important notices concerning this document and the product(s) described herein, have been included in section 'Legal information'.

© NXP B.V. 2018.

All rights reserved.

For more information, please visit: <http://www.nxp.com>

For sales office addresses, please send an email to: salesaddresses@nxp.com

Date of release: 12 April 2018
 Document identifier: MPL3115A2

Mouser Electronics

Authorized Distributor

Click to View Pricing, Inventory, Delivery & Lifecycle Information:

[NXP:](#)

[DEMOSTBMPL3115A2](#) [MPL3115A2R1](#) [MPL3115A2](#) [MPL3115A2T1](#)