

FRDM-HB2000-EVM evaluation board

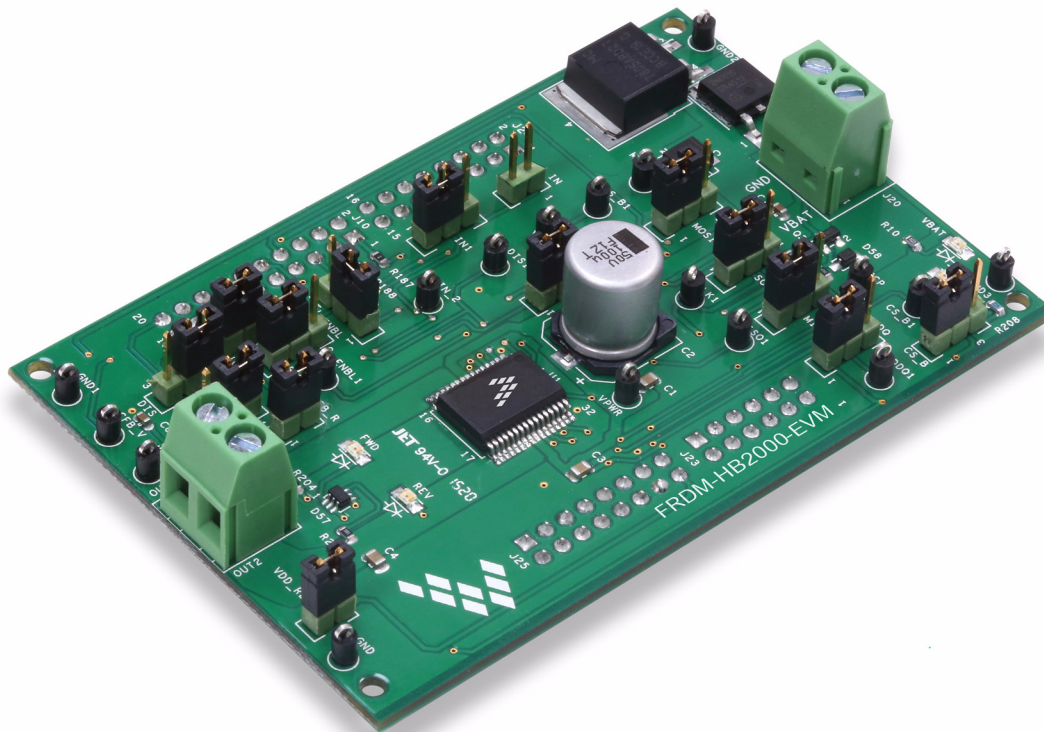

Figure 1. FRDM-HB2000-EVM

Contents

1	Important notice	3
2	Getting started	4
3	Getting to know the hardware	5
4	FRDM-KL25Z Freedom SPI dongle	14
5	Installing the software and setting up the hardware	18
6	Schematic	25
7	Board layout	26
8	Board bill of materials	27
9	Accessory item bill of materials	28
10	References	29
11	Revision history	30

1 Important notice

NXP provides the enclosed product(s) under the following conditions:

This evaluation kit is intended for use of ENGINEERING DEVELOPMENT OR EVALUATION PURPOSES ONLY. It is provided as a sample IC pre-soldered to a printed circuit board to make it easier to access inputs, outputs, and supply terminals. This evaluation board may be used with any development system or other source of I/O signals by simply connecting it to the host MCU or computer board via off-the-shelf cables. This evaluation board is not a Reference Design and is not intended to represent a final design recommendation for any particular application. Final device in an application will be heavily dependent on proper printed circuit board layout and heat sinking design as well as attention to supply filtering, transient suppression, and I/O signal quality.

The goods provided may not be complete in terms of required design, marketing and or manufacturing related protective considerations, including product safety measures typically found in the end product incorporating the goods. Due to the open construction of the product, it is the user's responsibility to take any and all appropriate precautions with regard to electrostatic discharge. In order to minimize risks associated with the customers applications, adequate design and operating safeguards must be provided by the customer to minimize inherent or procedural hazards. For any safety concerns, contact NXP sales and technical support services.

Should this evaluation kit not meet the specifications indicated in the kit, it may be returned within 30 days from the date of delivery and will be replaced by a new kit.

NXP reserves the right to make changes without further notice to any products herein. NXP makes no warranty, representation or guarantee regarding the suitability of its products for any particular purpose, nor does NXP assume any liability arising out of the application or use of any product or circuit, and specifically disclaims any and all liability, including without limitation consequential or incidental damages. "Typical" parameters can and do vary in different applications and actual performance may vary over time. All operating parameters, including "Typical", must be validated for each customer application by customer's technical experts.

NXP does not convey any license under its patent rights nor the rights of others. NXP products are not designed, intended, or authorized for use as components in systems intended for surgical implant into the body, or other applications intended to support or sustain life, or for any other application in which the failure of the NXP product could create a situation where personal injury or death may occur.

Should the Buyer purchase or use NXP products for any such unintended or unauthorized application, the Buyer shall indemnify and hold NXP and its officers, employees, subsidiaries, affiliates, and distributors harmless against all claims, costs, damages and expenses, and reasonable attorney fees arising out of, directly or indirectly, any claim of personal injury or death associated with such unintended or unauthorized use, even if such claim alleges NXP was negligent regarding the design or manufacture of the part. NXP™ and the NXP logo are trademarks of NXP Semiconductor, Inc. All other product or service names are the property of their respective owners.

© 2016 NXP B.V.

2 Getting started

2.1 Kit contents/packing list

The FRDM-HB2000-EVM contents includes:

- Assembled and tested evaluation board/module in anti-static bag
- FRDM-KL25Z
- Warranty card

2.2 Jump start

NXP's analog product development boards help to easily evaluate NXP products. These tools support analog mixed signal and power solutions including monolithic ICs using proven high-volume SMARTMOS mixed signal technology, and system-in-package devices utilizing power, SMARTMOS and MCU dies. NXP products enable longer battery life, smaller form factor, component count reduction, ease of design, lower system cost and improved performance in powering state of the art systems.

- Go to www.nxp.com/FRDM-HB2000-EVM
- Review the tool summary page
- Look for



Jump Start Your Design

- Download documents, software and other information

Once the files are downloaded, review the user guide in the bundle. The user guide includes setup instructions, BOM and schematics. Jump start bundles are available on each tool summary page with the most relevant and current information. The information includes everything needed for design.

2.3 Required equipment and software

To use this kit, you need:

- 3/16" blade screwdriver for connecting the cables
- DC Power supply: 5.0 V to 40 V with up to 20 A current handling capability, depending on motor requirements
- USB Standard A (male) to mini-B (male) cable
- Typical loads (brushed DC motor, power resistors or inductive load with up to 5.0 A and 28 V operation)
- Function generator (optional)
- FRDM-KL25Z Freedom Development Platform for SPI communication (included in KIT)
- SPIGen software from www.nxp.com (For using FRDM-KL25Z based SPI Dongle)

2.4 System requirements

The kit requires the following to function properly with the software:

- USB enabled computer with Windows XP or newer

3 Getting to know the hardware

3.1 Board overview

The FRDM-HB2000-EVM evaluation kit exercises all the functions of the MC33HB2000 H-Bridge device. The parallel input can be easily controlled by lab equipment or any MCU with GPIOs. The board can be used in conjunction with a FRDM-KL25Z board connected to a PC's USB port. Configure, control, and monitor the status of MC33HB2000 by using the board's SPI communication capabilities.

3.2 Board features

The FRDM-HB2000-EVM board evaluates the NXP part MC33HB2000, including all functions. The board features the following:

- Built-in reverse battery protection
- Test points allows probing its signals
- Built-in voltage regulator to supply logic level circuitry
- LEDs to indicate the supply status and the direction of the motor
- Low equivalent series resistance (ESR) capacitor to reduce ripple in the power supply
- Transient voltage suppressor to handle system level transients

3.3 Block diagram

The hardware block diagram is shown in [Figure 2](#).

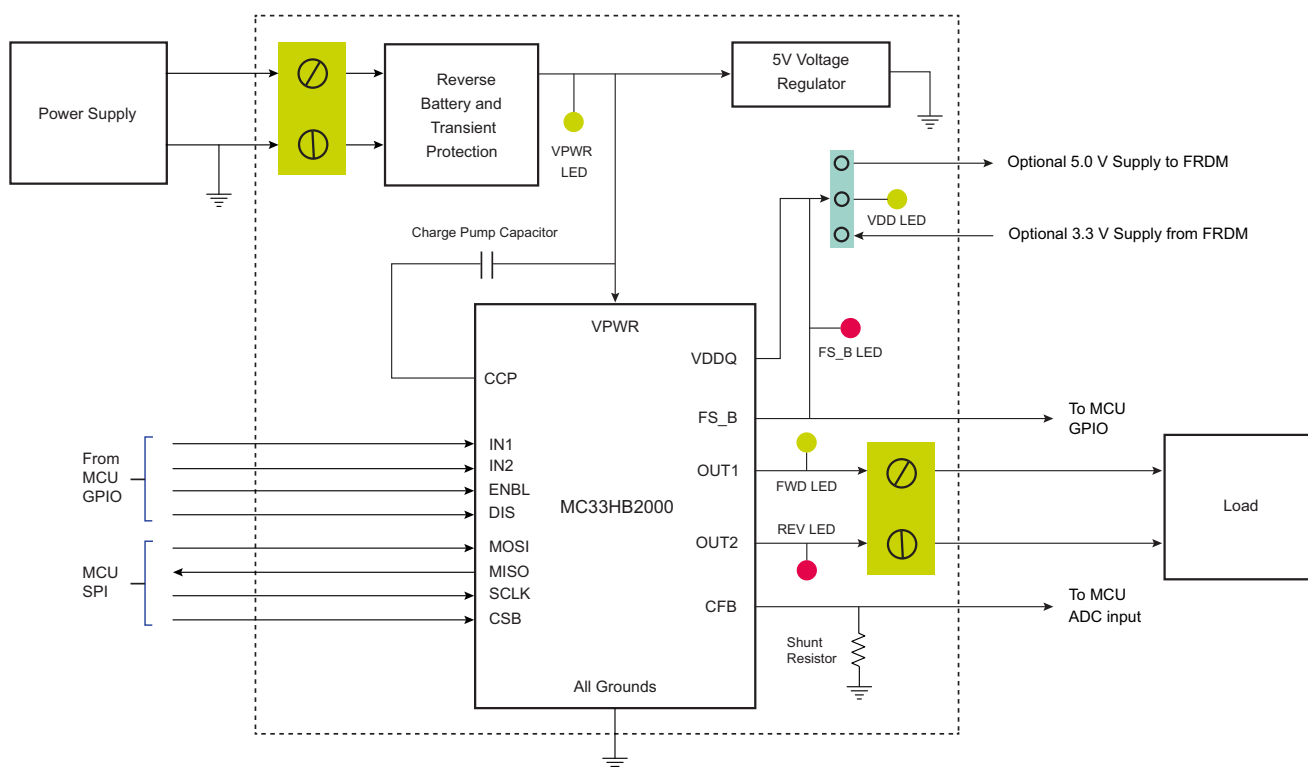

Figure 2. Block diagram

3.3.1 Device features

This evaluation board features the following NXP product:

Table 1. Features

Device	Description	Features
MC33HB2000	The 33HB2000 is a monolithic H-Bridge Power IC, enhanced with SPI configurability and diagnostic capabilities.	<ul style="list-style-type: none"> Advanced diagnostic reporting via a serial peripheral interface (SPI): charge pump undervoltage on VPWR, short to ground and short to VPWR for each output, open load, temperature warning and overtemperature shutdown Thermal management: Excellent thermal resistance of <math><1.0\text{ }^{\circ}\text{C/W}</math> between junction and case (exposed pad) Eight selectable slew rates via the SPI: 0.25 V/μs to more than 16 V/μs for EMI and thermal performance optimization Four selectable current limits via the SPI: 5.4/7.0/8.8/10.7 A, covering a wide range of applications Can be operated without the SPI with a default slew rate of 2.0 V/μs and a 7.0 A current limit threshold Highly accurate real-time current feedback through a current mirror output signal with less than 5.0% error Drives inductive loads in a full H-Bridge or Half-bridge configuration Overvoltage protection places the load in high-side recirculation (braking) mode with notification in H-Bridge mode Wide operating range: 5.0 V to 28 V operation Low $R_{DS(on)}$ integrated MOSFETs: Maximum of 235 mΩ ($T_J = 150\text{ }^{\circ}\text{C}$) for each MOSFET Internal protection for overtemperature, undervoltage and short-circuit by signaling the error condition and disabling the outputs I/O Pins can withstand up to 36 V

3.3.2 Modes of operation

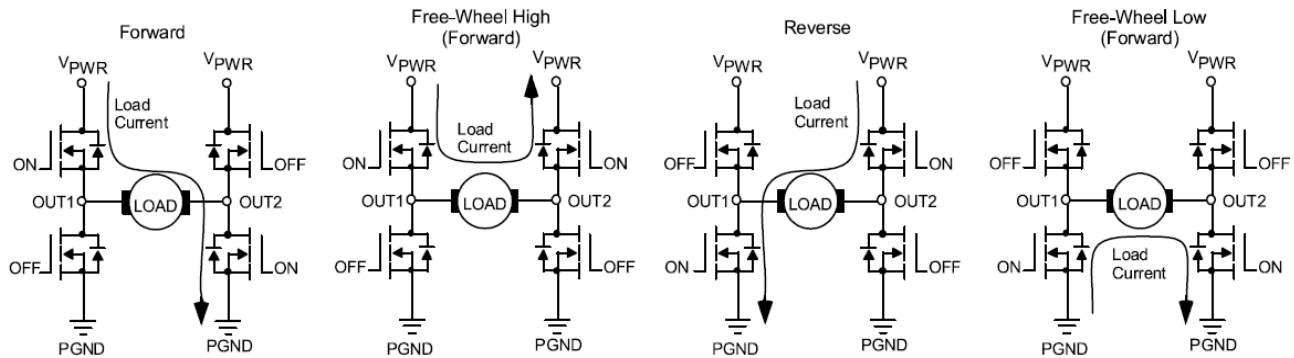

Figure 3. Modes of operation

3.3.3 Architecture

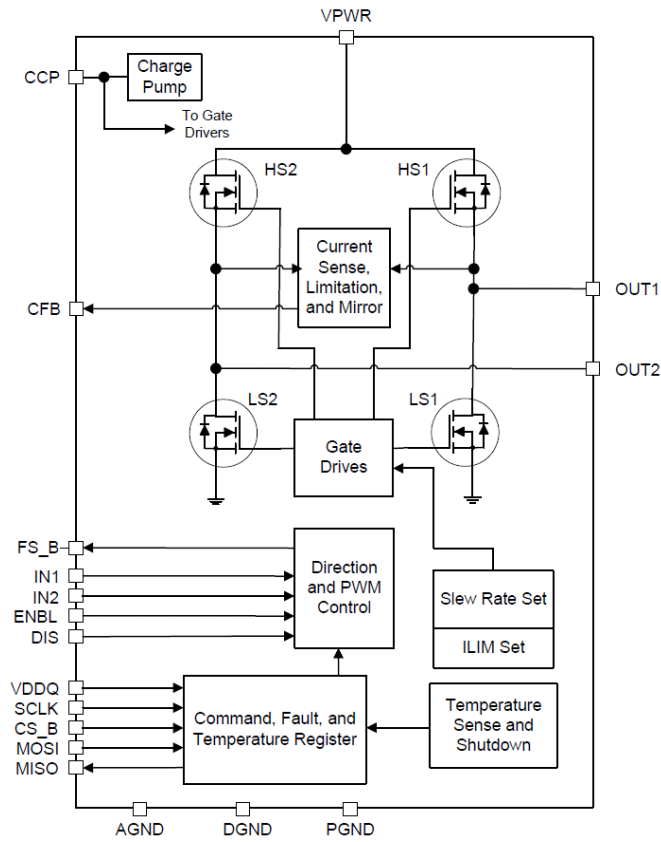

Figure 4. Architecture

3.3.4 Thermal management

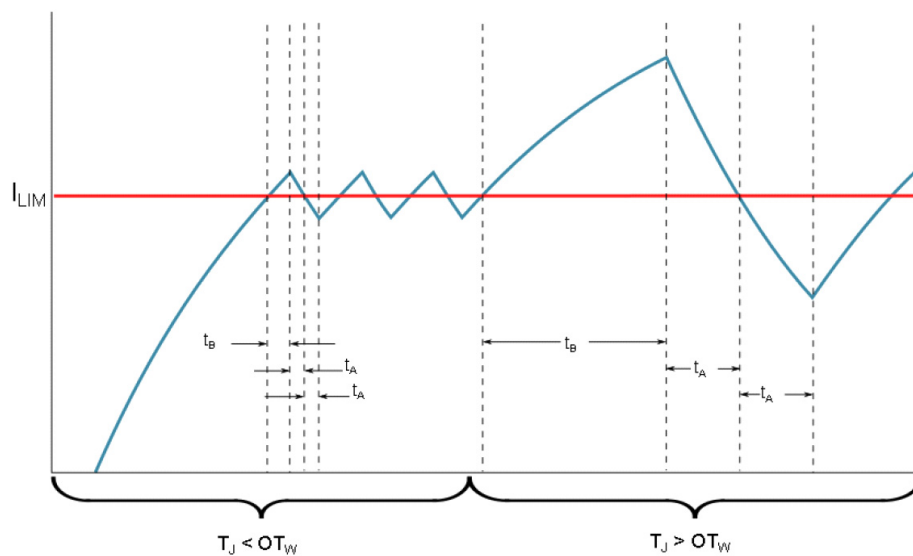

Figure 5. Architecture

3.4 Board description

Figure 6 describes the main elements on the FRDM-HB2000-EVM.

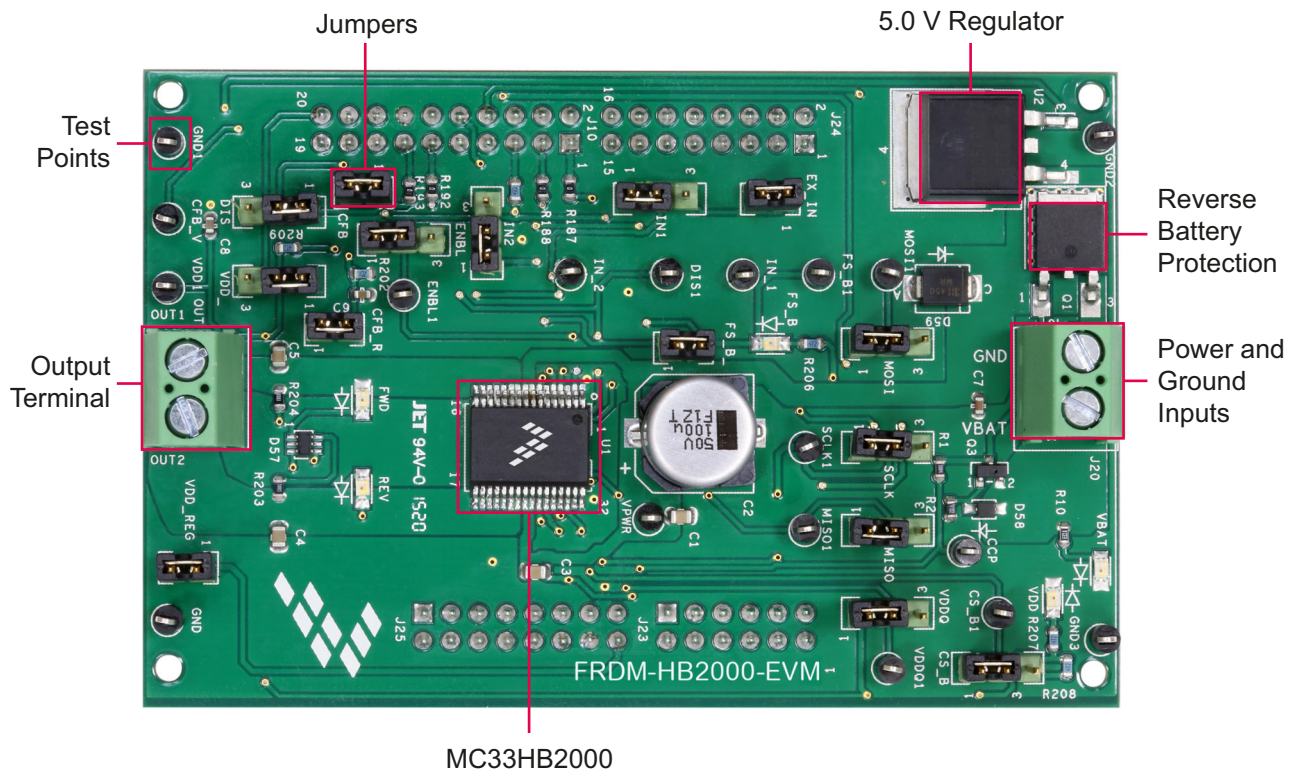

Figure 6. Board description

Table 2. Board Description

Name	Description
MC33HB2000	Monolithic H-Bridge power IC in a robust thermally enhanced 32 lead SOIC-EP package
5.0 V Regulator	5.0 V regulator for VDD and supply
Jumpers	Jumpers for configuring the board for different modes of operation
Reverse Battery Protection	MOSFET for protecting MC33HB2000 in reverse battery condition
Power and Ground inputs	Power supply terminal to connect the battery/power supply with the board
Test Points	Test points to probe different signals
Output terminal	Output connector to connect a load to the MC33HB2000 output

3.5 LED display

The following LEDs serve as visual output devices for the evaluation board:

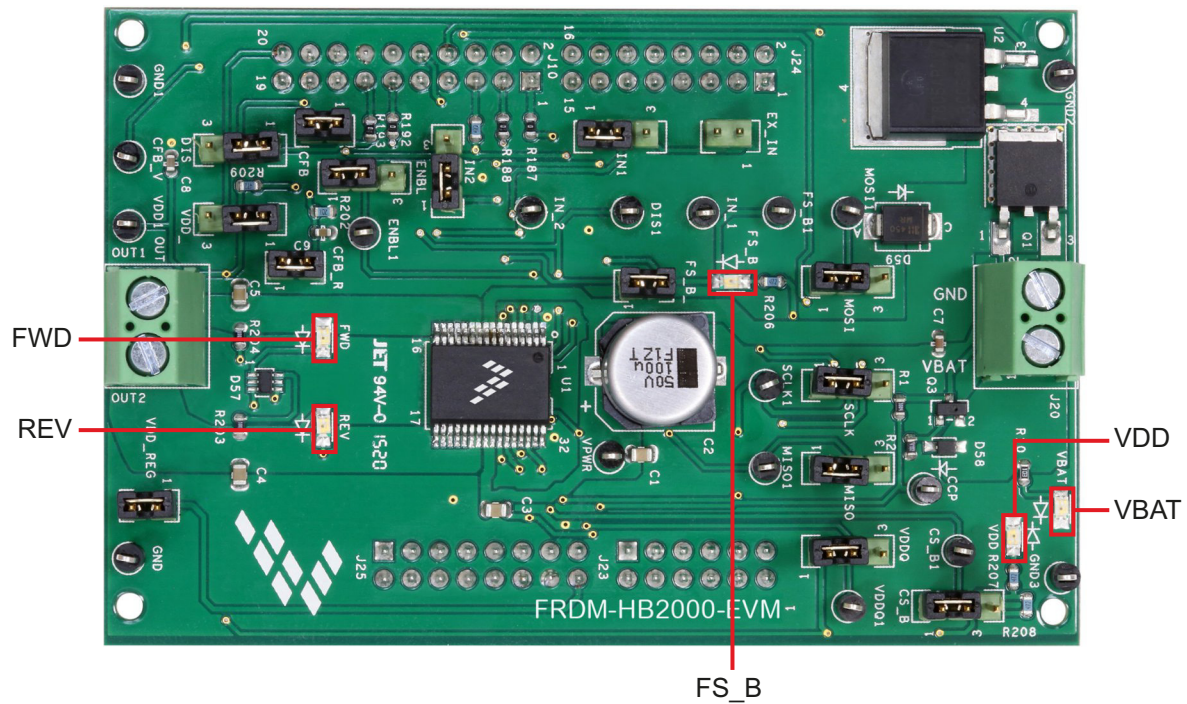

Figure 7. LED locations

Table 3. LED display

LED ID	Description
VBAT	GREEN LED, indicates when main/battery supply is connected
VDD	GREEN LED, indicates when +5.0 V supply is connected
FS_B	RED LED, illuminates when the H-Bridge detects a fault
FWD	GREEN LED, indicates current flowing in forward direction
REV	RED LED, indicates current flowing in reverse direction

3.6 Jumper definitions

The [Figure 8](#) illustrates the evaluation board jumper locations. [Table 4](#) explains the function of each position. Blue fonts in the Jumper Position column indicate the default settings for use with the FRDM-KL25Z.

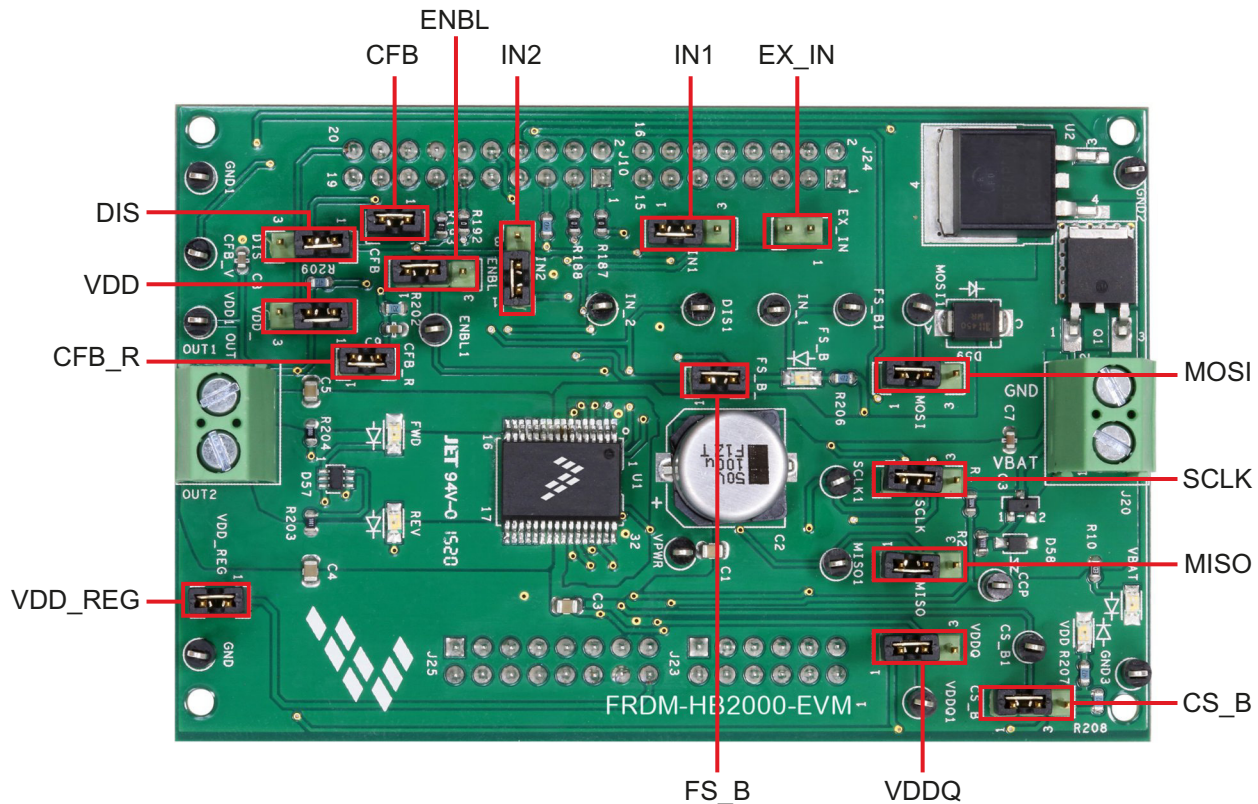

Figure 8. Jumper locations

Table 4. Jumper definitions

Name	Signal	Jumper position	Connection
J1	IN1	1-2	IN1 control through MCU parallel output on J10 Pin 1 (DATA0)
		2-3	IN1 control through external input on J15 Pin 1
J2	DIS	1-2	DIS control through MCU parallel output on J10 Pin 13 (CTRL1)
		2-3	DIS connected to GND to keep the outputs enabled
J3	IN2	1-2	IN2 control through MCU parallel output on J10 Pin 3 (DATA1)
		2-3	IN2 control through external input on J15 Pin 2
J4	CS_B	1-2	CS_B control through MCU SPI output J10 Pin 6 (SPI_CS_B)
		2-3	CS_B pulled up to V _{DD} for operation without SPI
J5	ENBL	1-2	ENBL control through MCU parallel output J10 Pin 11 (CTRL0)
		2-3	ENBL pulled up to V _{DD} to keep the outputs enabled
J6	SCLK	1-2	SPI clock SCLK from MCU J10 Pin 12 (SPI_SCLK)
		2-3	SCLK connected to GND for operation without SPI
J7	MOSI	1-2	MOSI control through MCU SPI output J10 Pin 8 (SPI_MOSI)
		2-3	MOSI connected to GND for operation without SPI
J8	MISO	1-2	MISO control through MCU SPI output J10 Pin 10 (SPI_MISO)
		2-3	MISO not connected for operation without SPI
J11	CFB	1-2	CFB connected to 200 Ω resistor
J14	VDDQ	1-2	VDD connected to VDDQ
		2-3	VDDQ not connected

Table 4. Jumper definitions (continued)

Name	Signal	Jumper position	Connection
J17	VDD	1-2	V _{DD} supply from regulator U2
		2-3	V _{DD} supply from FRDM board
J18	CFB_R	1-2	CFB connected to MCU ADC input J10 Pin 17 (CFB_READ)
J19	FS_B	1-2	FS_B connected to the pull-up resistor
J26	VDD_REG	1-2	V _{DD} to FRDM board
J15	EX_IN	Open	IN1 and IN2 External Inputs

The FRDM-HB2000-EVM, in conjunction with a FRDM-KL25Z board (shipped with the kit), can evaluate the design by means of a GUI, any MCU with GPIO or with simple lab equipment. A FRDM-KL25Z-compatible GUI and MCU program are available online at the following link: www.nxp.com/FRDM-HB2000-EVM.

The FRDM-HB2000-EVM is compatible with any Arduino™ platform board. However, if a board other than the FRDM-KL25Z is used, MCU code must be written to work with the board.

3.7 Input signal definitions

The following input signals control the outputs or functions inside the circuit.

Table 5. Input signal definitions

Input Name	Description
DIS	Disable signal to tri-state the outputs
ENBL	Disable signal to tri-state the output and put the part in Sleep mode
IN1	Logic input to control OUT1
IN2	Logic input to control OUT2
MOSI	Master out slave input for the SPI
CS_B	Chip select bar input for the SPI
SCLK	Clock for the SPI

3.8 Output signal definitions

The FRDM-HB2000-EVM uses the following output signals to drive a load such as a brushed DC motor. The board provides an analog output for real time load current monitoring. This signal allows closed loop control of the load.

Table 6. Output signal definitions

Output Name	Description
OUT1	Output 1 of H-Bridge
OUT2	Output 2 of H-Bridge
FS_B	Open drain Active Low status flag output to indicate fault
CFB	Current mirror output for real time load current monitoring
MISO	Master input slave output for SPI

3.9 Test point definitions

The following test points provide access to various signals to and from the board.

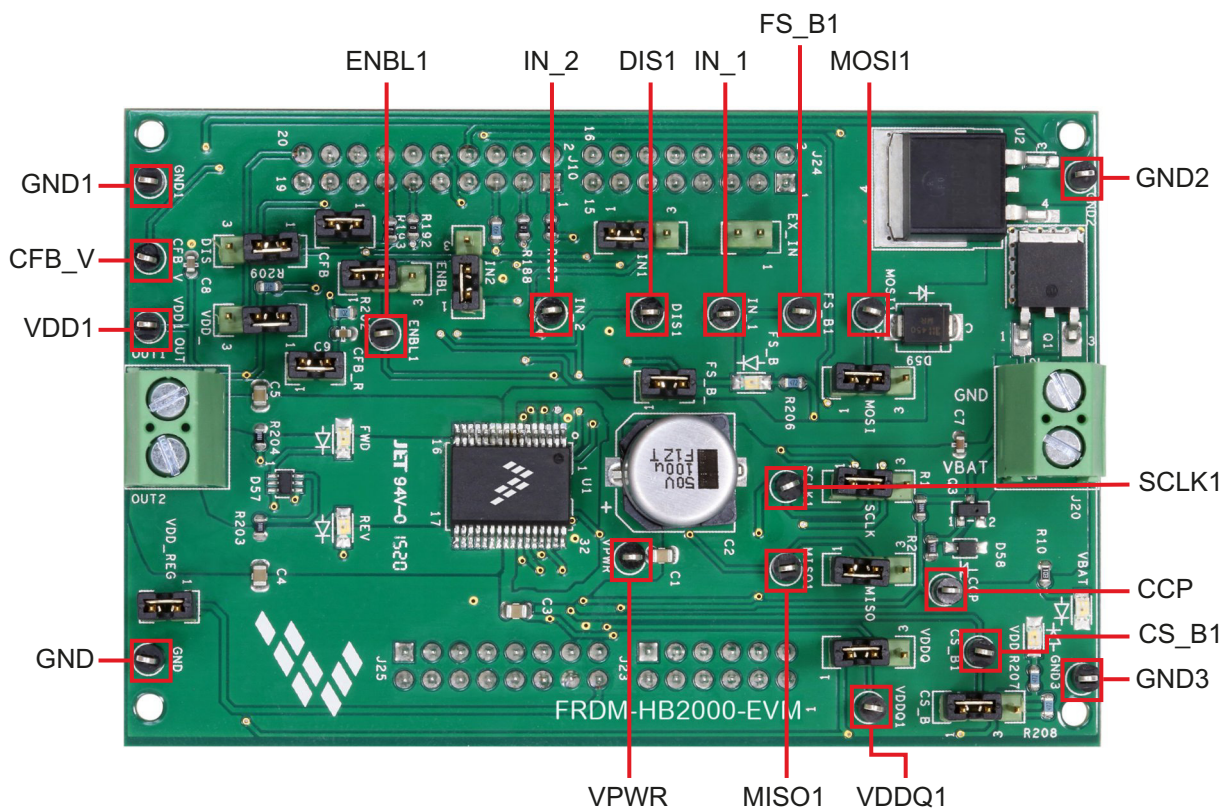

Figure 9. Test point locations

Table 7. Test point definitions

Test point name	Signal name	Description
CFB_V	CFB_READ	CFB pin voltage going to ADC
CCP	CCP	Charge pump voltage
ENBL1	ENBL	Enable/disable signal to activate/tri-state the outputs and put the device to sleep mode
DIS1	DIS	Enable/disable signal to activate/tri-state the outputs
IN_1	IN1	Direction control in H-Bridge mode and OUT1 control in half-bridge mode
IN_2	IN2	PWM control in H-Bridge mode and OUT2 control in half-bridge mode
VPWR	VPWR	System voltage
VDDQ1	VDDQ	VDDQ digital output supply voltage
FSB1	FSB	Fault status monitoring pin
VDD1	VDD	V _{DD} supply for the part
CS_B1	CS_B	Chip select bar
SCLK1	SCLK	Clock for SPI
MOSI1	MOSI	Master output slave input signal
MISO1	MISO	Master input slave output signal
GND	GND	Ground signal
GND1	GND	Ground signal
GND2	GND	Ground signal
GND3	GND	Ground signal

3.10 Screw terminal connections

The board has the following screw terminal connections to connect the power supply and the load.

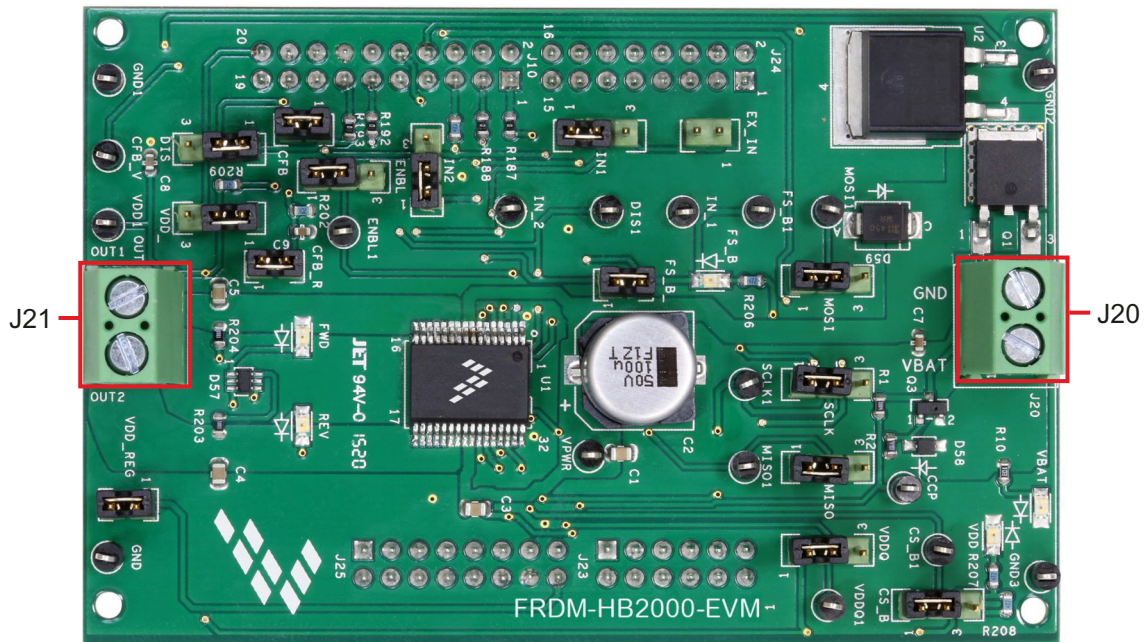

Figure 10. Screw terminal locations

Table 8. Screw terminal connections

Screw Terminal Name	Description
J20	Power supply connector for the MC33HB2000
J21	Output connector to connect load

4 FRDM-KL25Z Freedom SPI dongle

The NXP Freedom development platform is a set of software and hardware tools supporting evaluation and development. It is ideal for rapid prototyping of microcontroller-based applications. The NXP Freedom KL25Z hardware, FRDM-KL25Z, is a simple, yet sophisticated design featuring a Kinetis L series microcontroller, the industry's first microcontroller built on the ARM® Cortex™-M0+ core.

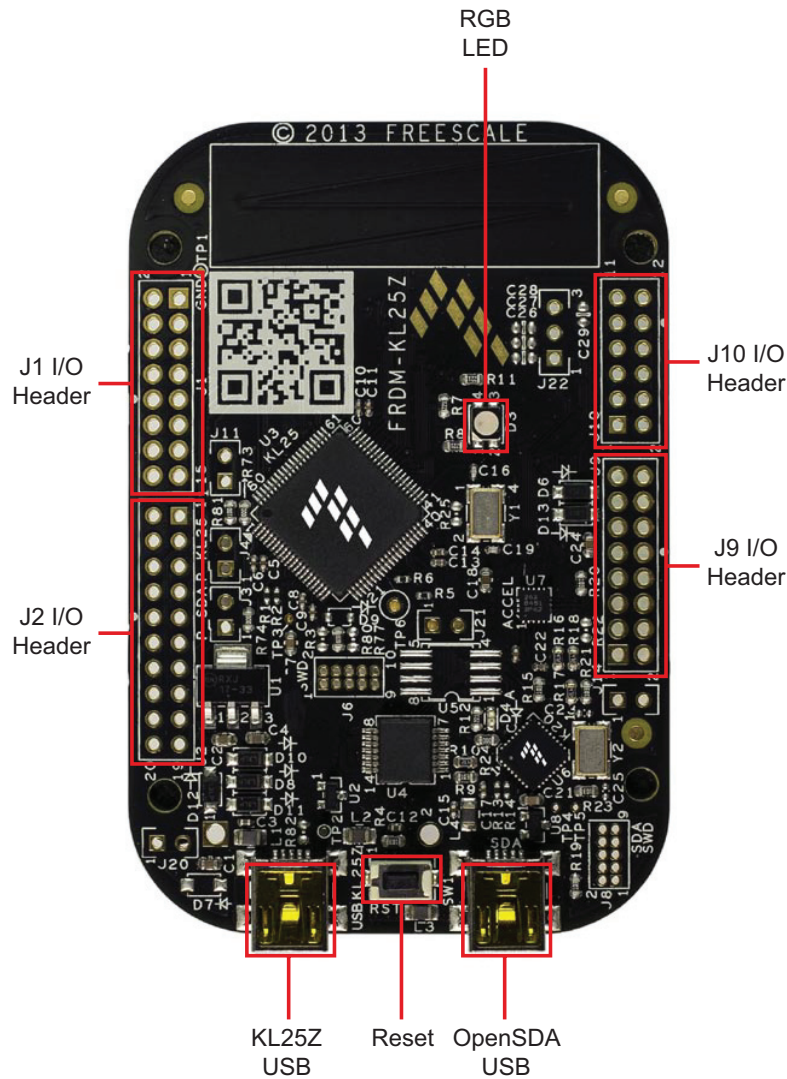

Figure 11. FRDM-KL25Z

4.1 Connecting the FRDM-KL25Z to the board

The FRDM-KL25Z evaluation board was chosen specifically to work with the FRDM-HB2000-EVM kit because of its low cost and features. The FRDM-KL25Z board makes use of the USB, built in LEDs and I/O ports available with NXP's Kinetis KL2x family of microcontrollers. The FRDM-KL25Z connects to a PC through a USB port, which permits the user to control a DC brushed motor and to drive the evaluation board inputs in order to operate the motor via the GPIOs and SPI pins. The FRDM-KL25Z also monitors the SPI registers, thereby facilitating the use of safety and advanced diagnostic functions.

The FRDM-HB2000-EVM connects to the FRDM-KL25Z using the four dual row Arduino™ R3 connectors on the bottom of the board (see [Table 9](#), [Figure 12](#), and [Figure 13](#)).

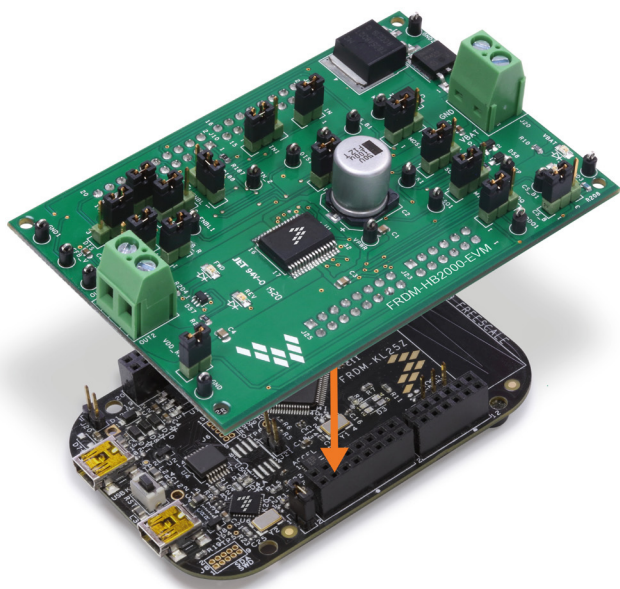

Figure 12. Connecting the FRDM-HB2000-EVM to the FRDM-KL25Z

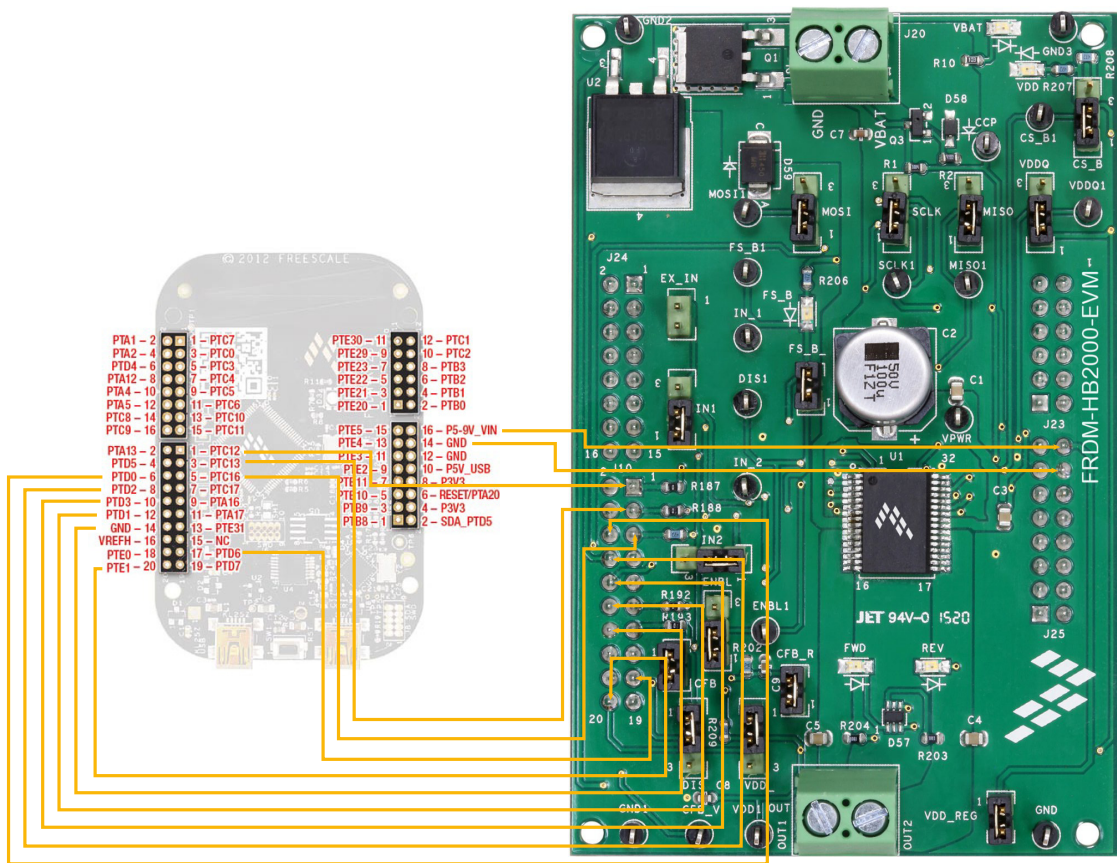

Figure 13. FRDM-KL25Z to FRDM-HB2000-EVM connections

Table 9. FRDM-HB2000-EVM to FRDM-KL25Z Connections

FRDM-HB2000-EVM		FRDM-KL25Z		Pin hardware name		Description
Header	Pin	Header	Pin	FRDM-HB2000-EVM	FRDM-KL25Z	
J24	1	J1	1	N/C	PTC7	No connection
J24	2	J1	2	N/C	PTA1	No connection
J24	3	J1	3	N/C	PTC0	No connection
J24	4	J1	4	N/C	PTA2	No connection
J24	5	J1	5	N/C	PTC3	No connection
J24	6	J1	6	N/C	PTD4	No connection
J24	7	J1	7	N/C	PTC4	No connection
J24	8	J1	8	N/C	PTA12	No connection
J24	9	J1	9	N/C	PTC5	No connection
J24	10	J1	10	N/C	PTA4	No connection
J24	11	J1	11	N/C	PTC6	No connection
J24	12	J1	12	N/C	PTA5	No connection
J24	13	J1	13	N/C	PTC10	Not connection
J24	14	J1	14	N/C	PTC8	No connection
J24	15	J1	15	N/C	PTC11	Not connection
J24	16	J1	16	N/C	PTC9	No connection
J10	1	J2	1	DATA0/IN1	PTC12	IN1 signal for the H-Bridge
J10	2	J2	2	N/C	PTA13	No connection
J10	3	J2	3	DATA1/IN2	PTC13	IN2 signal for the H-Bridge
J10	4	J2	4	N/C	PTD5	No connection
J10	5	J2	5	FS_B	PTC16	Fault status pin to report fault
J10	6	J2	6	CS_B	PTD0	Chip select bar pin
J10	7	J2	7	N/C	PTC17	No connection
J10	8	J2	8	MOSI	PTD2	Master output serial input
J10	9	J2	9	N/C	PTA16	No connection
J10	10	J2	10	MISO	PTD3	Master input serial output
J10	11	J2	11	N/C	PTA17	No connection
J10	12	J2	12	SCLK	PTD1	Clock for SPI
J10	13	J2	13	N/C	PTE31	No connection
J10	14	J2	14	GND	GND	No connection
J10	15	J2	15	N/C	N/C	No connection
J10	16	J2	16	N/C	VREFH	No connection
J10	17	J2	17	CFB_READ	PTD6	ADC input for monitoring the CFB pin
J10	18	J2	18	N/C	PTE0	Disable signal to tri-state the output and put the part in sleep mode (Active Low)

Table 9. FRDM-HB2000-EVM to FRDM-KL25Z Connections (continued)

FRDM-HB2000-EVM		FRDM-KL25Z		Pin hardware name		Description
Header	Pin	Header	Pin	FRDM-HB2000-EVM	FRDM-KL25Z	
J10	19	J2	19	N/C	PTD7	No connection
J10	20	J2	20	FRDM_VDD	PTE1	No connection
J23	1	J10	1	N/C	PTE20	No connection
J23	2	J10	2	N/C	PTB0	No connection
J23	3	J10	3	N/C	PTE21	No connection
J23	4	J10	4	N/C	PTB1	No connection
J23	5	J10	5	N/C	PTE22	No connection
J23	6	J10	6	N/C	PTB2	No connection
J23	7	J10	7	N/C	PTE23	No connection
J23	8	J10	8	N/C	PTB3	No connection
J23	9	J10	9	N/C	PTE29	No connection
J23	10	J10	10	N/C	PTC2	No connection
J23	11	J10	11	N/C	PTE30	No connection
J23	12	J10	12	N/C	PTC1	No connection
J25	1	J9	1	N/C	PTB8	No connection
J25	2	J9	2	N/C	SDA_PTD5	No connection
J25	3	J9	3	N/C	PTB9	No connection
J25	4	J9	4	N/C	P3V3	No connection
J25	5	J9	5	N/C	PTB10	No connection
J25	6	J9	6	N/C	RESET/PTA20	No connection
J25	7	J9	7	N/C	PTB11	No connection
J25	8	J9	8	N/C	P3V3	No connection
J25	9	J9	9	N/C	PTE2	No connection
J25	10	J9	10	N/C	P5V_USB	No connection
J25	11	J9	11	N/C	PTE3	No connection
J25	12	J9	12	GND	GND	Ground
J25	13	J9	13	N/C	PTE4	No connection
J25	14	J9	14	GND	GND	No connection
J25	15	J9	15	N/C	PTE5	No connection
J25	16	J9	16	VDD_REG	P5-9V_VIN	5.0 V logic input to FRDM-KL25Z board from FRDM-HB2000-EVM

5 Installing the software and setting up the hardware

5.1 Configuring the hardware

The FRDM-HB2000-EVM consists of an H-Bridge, a parallel and SPI interface, power conditioning circuitry and an FRDM-KL25Z board. The board can be configured for use in conjunction with a FRDM-KL25Z board or a function generator.

Caution:

When using the FRDM-HB2000-EVM, make sure that the maximum motor supply voltage (VPWR) stays within the 5.0 V to 40 V range. Operating outside this range may cause damage to the board.

5.1.1 Step-by-step instructions for setting up the hardware for use with a FRDM-KL25Z

To configure the FRDM-HB2000-EVM for use with the FRDM-KL25Z do the following:

1. Connect the FRDM-HB2000-EVM to the FRDM-KL25Z using the Arduino™ connectors on each board.
2. Connect the USB cable (not supplied with the kit) between the PC and the KL25Z USB port on the FRDM-KL25Z board.
3. With the power switched off, attach the DC power supply to the VBAT and GND screw connector terminal (J20) on the evaluation board.
4. Connect the load to the screw terminal (J21).

Figure 14 illustrates the hardware configuration using a FRDM-KL25Z.

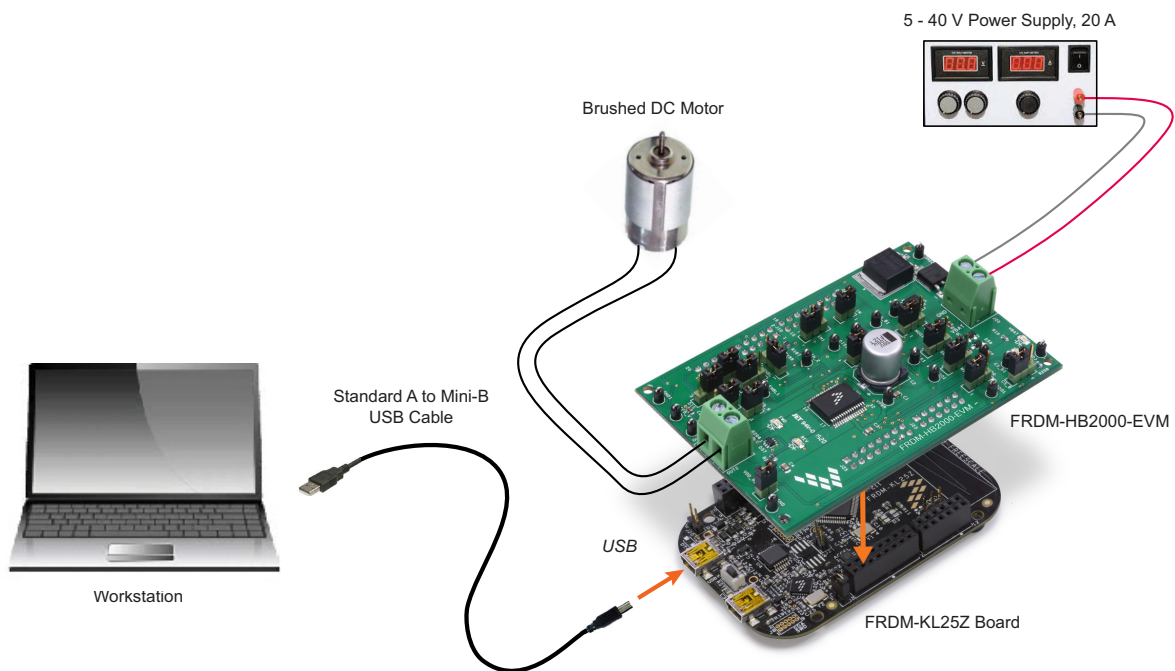

Figure 14. FRDM-HB2000-EVM configured for use with an FRDM-KL25Z board

5.1.2 Step-by-step instructions for setting up the hardware for use with a function generator

This section describes how to configure the FRDM-HB2000-EVM for use with a function generator. The same connections apply if the board is connected to a microcontroller instead of a function generator. See the board description ([Section 3.4, Board description, page 8](#)), the schematic ([Section 6, Schematic, page 25](#)) and the MC33HB2000 datasheet, to configure the board for use in a specific environment.

1. Connect the function generator to the EX_IN jumper, with one channel attached to each pin.
2. Change the board jumper connections, as shown in [Figure 15](#).
3. With the power switched off, attach the DC power supply to the VBAT and GND screw connector terminal (J20) on the evaluation board.
4. Connect the load to the screw terminal (J21).

[Figure 15](#) illustrates the hardware configuration.

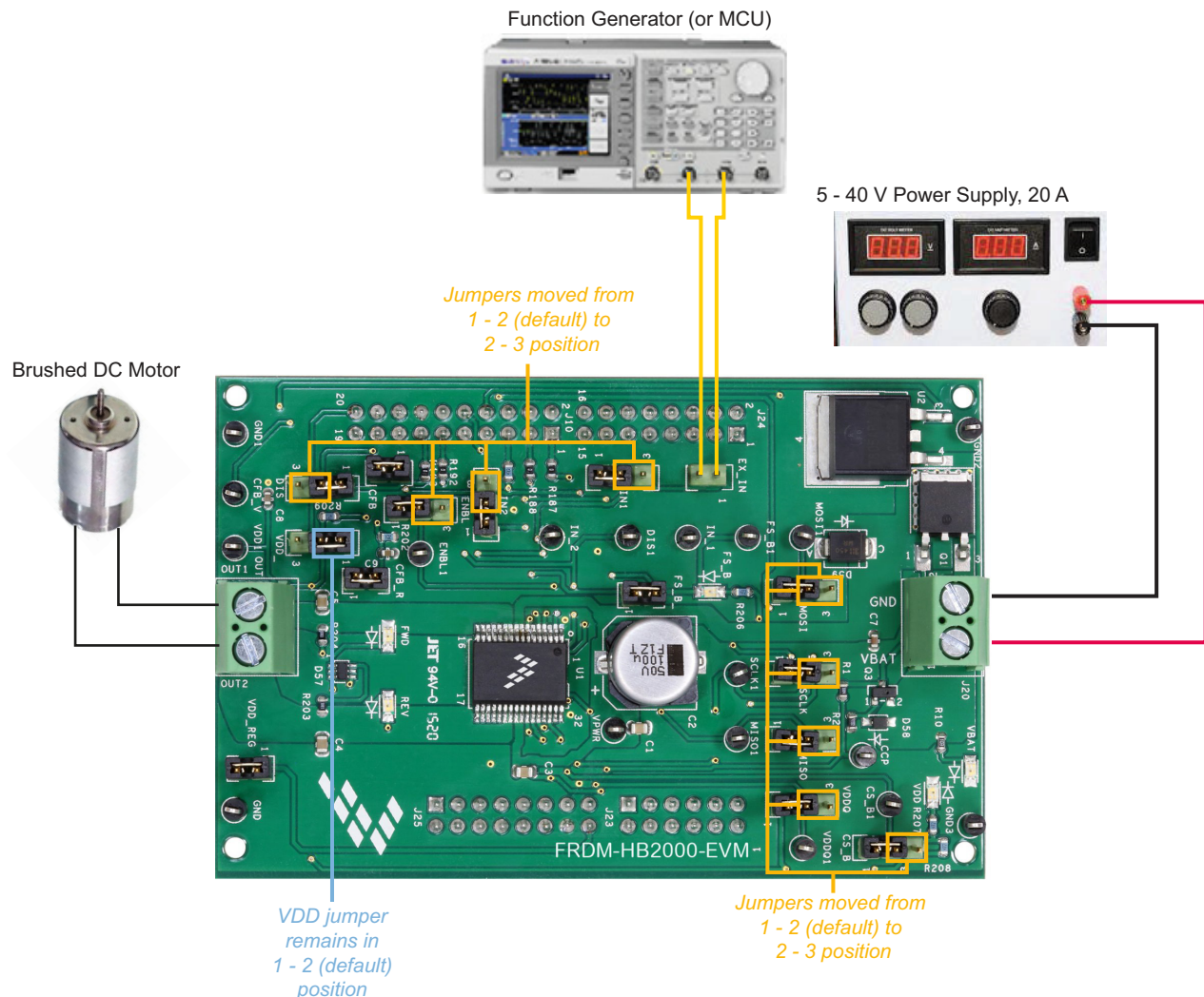

Figure 15. FRDM-HB2000-EVM configured for use with a function generator

5.2 Installing and using SPIGen on the computer

The latest version of SPIGen supports the MC33HB2000 and is designed to run on any Windows 8, Windows 7, Vista, or XP-based operating system. To install the software, do the following:

1. Go to the following website and click on the **Download** button: www.nxp.com/SPIGen.
2. When the **SPIGEN: SPI Generator (SPIGen) Software** page appears, go to the **Device Drivers** section and click on the **Download** button associated with the description of the select environment. A wizard guides the user through the process.
3. If instructed for the SPIGen wizard to create a short-cut, a SPIGen icon appears on the desktop. If elected not to create a short-cut, the SPIGen executable is installed by default at C:\Program Files\SPIGen.

Note:

Installing the device drivers overwrites any previous SPIGen installation and replaces it with a current version containing the MC33HB2000 drivers. However, configuration files (.spi) from the previous version remain intact.

4. Launch SPIGen. The HB2000/HB2001 device should appear in the device view panel at the left (see [Figure 14](#)).

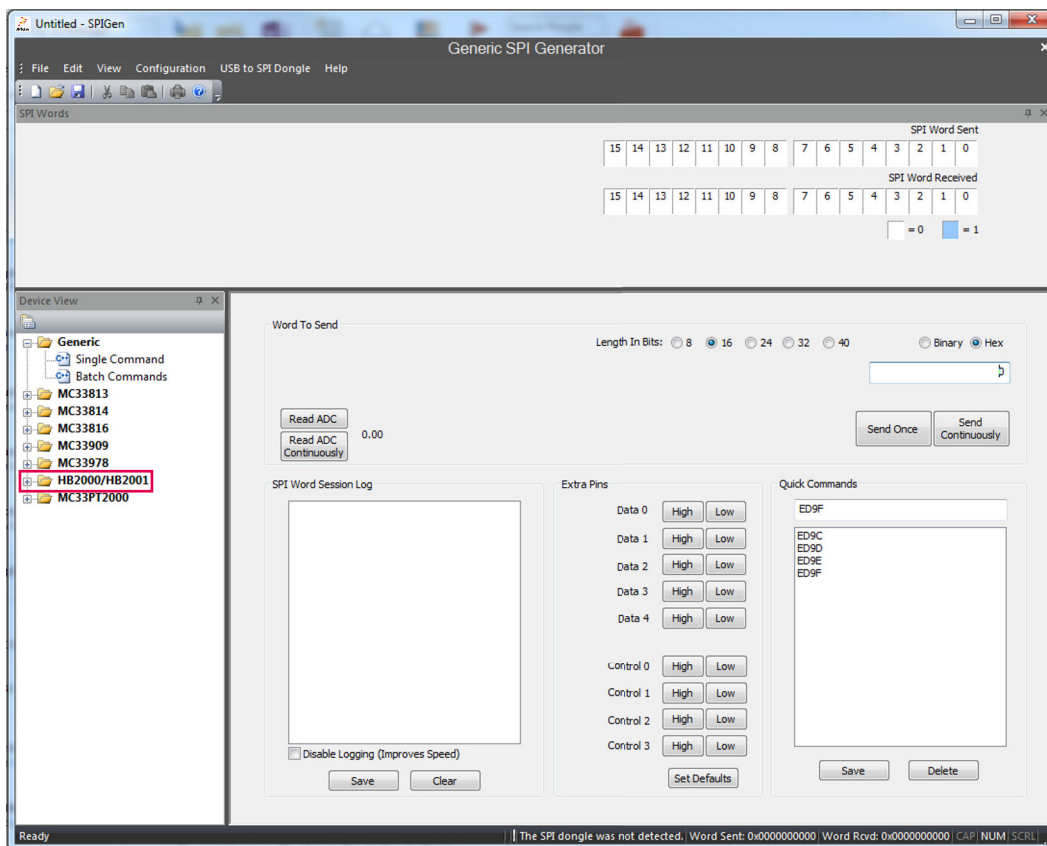

Figure 16. SPIGen home page

5. To access the HB2000/HB2001 tab in the SPIGen window, expand the HB2000/HB2001 folder in the device view. Then click on the **Registers** icon (see [Figure 17](#)).

If the pre-programmed code on FRDM-KL25Z is accidentally erased, download "UsbSpiDongleKL25Z_SPIDrive_v512.src" from the following link: www.nxp.com/Usb-Spi-Dongle-firmware-KL25Z-HB2000-1.

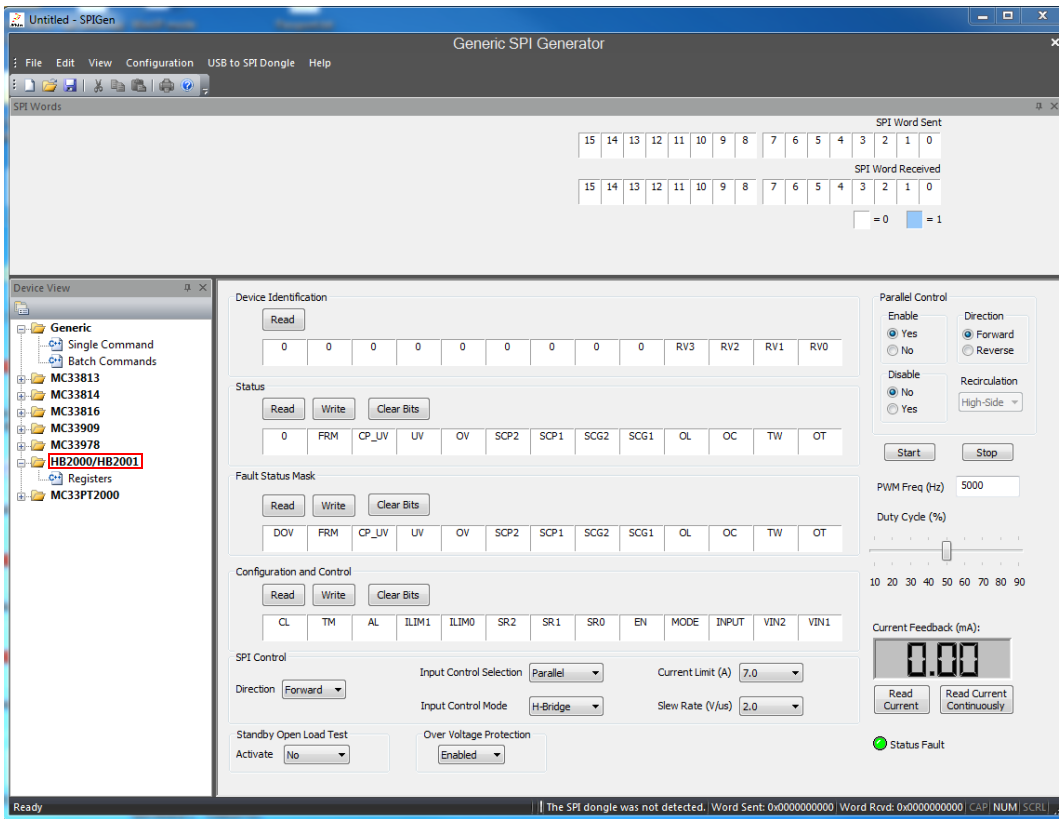

Figure 17. MC33HB2000 SPI window

6. Reading all the SPI registers displays the following default status.

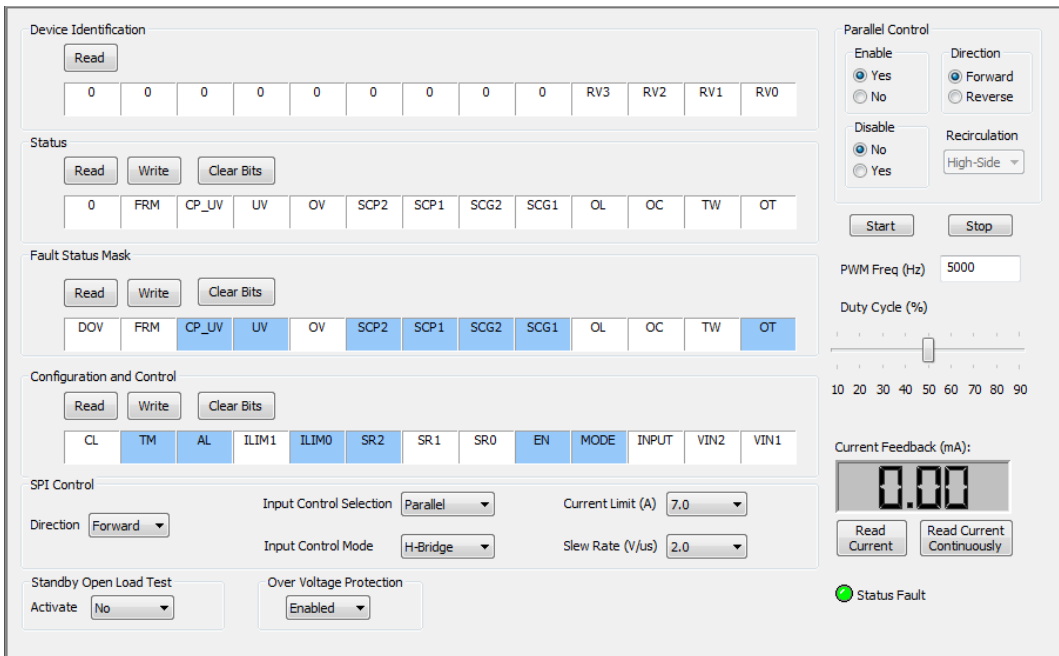

Figure 18. SPI control

5.2.0.1 SPI control

The screenshot displays a software interface for SPI control, organized into five main sections:

- Device Identification:** Features a 'Read' button and a row of 13 bits (0, 0, 0, 0, 0, 0, 0, 0, 0, 0, RV3, RV2, RV1, RV0).
- Status:** Includes 'Read', 'Write', and 'Clear Bits' buttons, with a row of 13 bits (0, FRM, CP_UV, UV, OV, SCP2, SCP1, SCG2, SCG1, OL, OC, TW, OT).
- Fault Status Mask:** Includes 'Read', 'Write', and 'Clear Bits' buttons, with a row of 13 bits (DOV, FRM, CP_UV, UV, OV, SCP2, SCP1, SCG2, SCG1, OL, OC, TW, OT).
- Configuration and Control:** Includes 'Read', 'Write', and 'Clear Bits' buttons, with a row of 13 bits (CL, TM, AL, ILIM1, ILIM0, SR2, SR1, SR0, EN, MODE, INPUT, VIN2, VIN1).
- SPI Control:** A highlighted section containing:
 - Direction: Forward
 - Input Control Selection: Parallel
 - Current Limit: 6.7
 - Input Control Mode: H-Bridge
 - Slew Rate: 2.0
 - Open Load Test Activate: No

Figure 19. SPI control description

Table 10. SPI control description

Name	Description
Read	Click the read button on top of each register to read the content of each register.
Write	Click individual bits of any register and then press the corresponding write button to write into the register.
SPI control	This section is designed for ease of use. Each dropdown menu sets or resets appropriate bits in the registers for a selected configuration. However, after configuration selection, press the write button of the corresponding register to be able to configure the part.

5.2.0.2 Parallel control

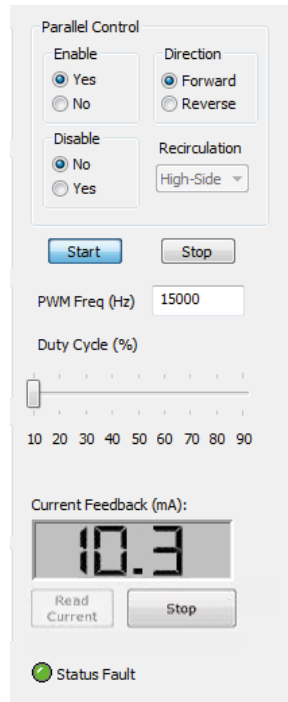

Figure 20. Parallel control description

Direction:

- **Forward:** Current flowing through OUT1 to OUT2
- **Reverse:** Current flowing through OUT2 to OUT1

Recirculation:

- **High-side:** Freewheel-High (both high-side FETs turned on) during PWMing
- **Low-side:** Freewheel-Low (both low-side FETs turned on) during PWMing (only valid for Half-Bridge mode)

ENBL:

- **Yes:** ENBL is logic HIGH, the H-Bridge is operational
- **No:** ENBL is logic LOW, the H-Bridge outputs are tri-stated and placed in sleep mode

DIS:

- DIS is logic HIGH, both OUT1 and OUT2 are tri-stated
- DIS is logic LOW, both OUT1 and OUT2 are enabled

PWM Freq:

- Enter PWM frequency up to 20000 Hz

Duty Cycle:

- Select PWM duty cycle from 10-90%

Start:

- After selection of parallel control configuration, press “**Start**” to activate the outputs

Stop:

- Press “**Stop**” to deactivate the outputs

Current Feedback:

- Shows current through the high-side FET using the current recopy feature

Status Fault:

- Shows any fault condition in sleep mode

Table 11. Logic behind direction control with high-side versus low-side recirculation

Half-Bridge Mode	
1	Forward - High-side recirculation
	IN1 = 1, IN2 = PWM signal with selected duty cycle and frequency
2	Reverse - High-side recirculation
	IN1 = PWM signal with selected duty cycle and frequency, IN2 = 1
3	Forward - Low-side recirculation
	IN1 = PWM signal with selected duty cycle and frequency, IN2 = 0
4	Reverse - Low-side recirculation
	IN1 = 0, IN2 = PWM signal with selected duty cycle and frequency
H-Bridge Mode	
1	Forward - High-side recirculation
	IN1 = 1, IN2 = PWM signal with selected duty cycle and frequency
2	Reverse - High-side recirculation
	IN1 = 0, IN2 = PWM signal with selected duty cycle and frequency

7 Board layout

7.1 Silkscreen

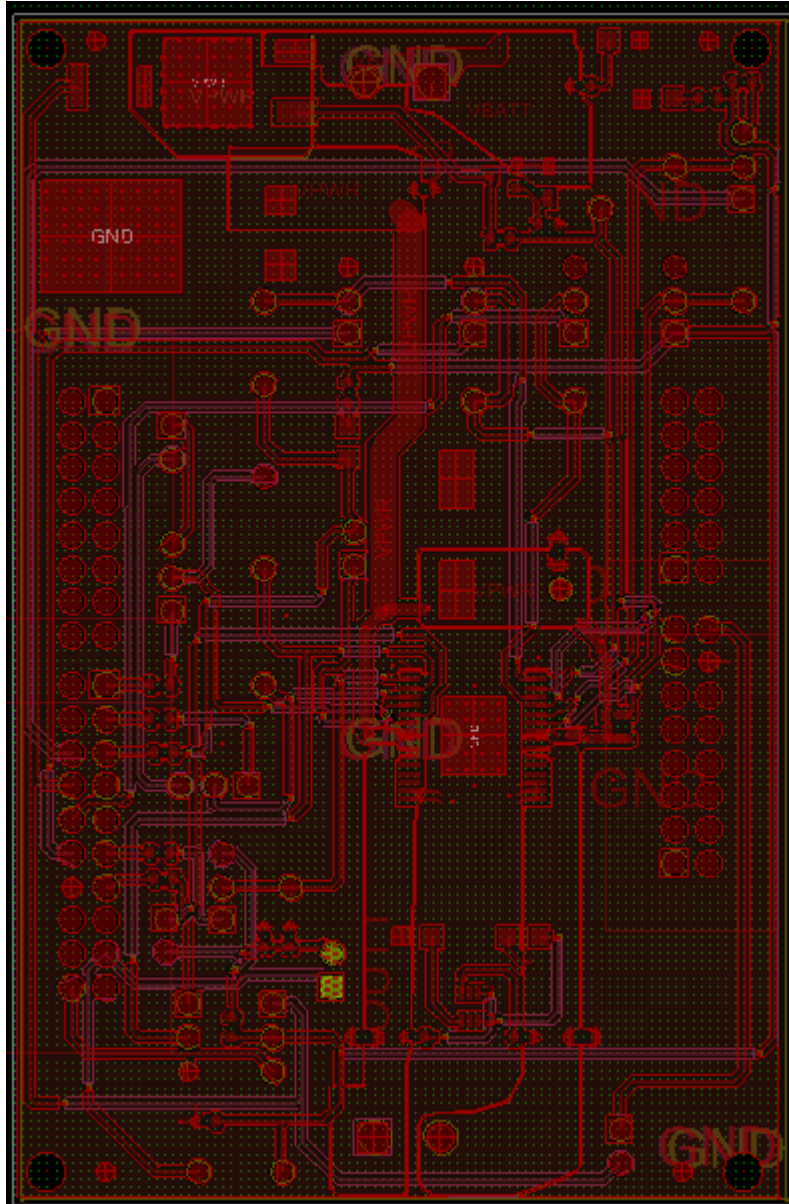

8 Board bill of materials

Table 12. Bill of materials ⁽¹⁾

Item	Qty	Schematic Label	Value	Value/Description	Part Number	Assy Opt
Active Components						
1	1	U1		IC DRV H-BRIDGE MOTOR 3.0 A 5.0 to 28 V SOIC32—NXP	MC33HB2000EK	(2)
2	1	U2		IC VREG 5.0 V 1.0 A 5.0 to 18 V D2PAK—ON Semiconductor	MC7805ABD2TG	(2)
Diodes						
3	1	D2	24 V	DIODE TVS UNIDIR 600 W 24 V AEC-Q101 SMB	SMBJ24AHE3/52	
4	1	D57	70 V	DIODE SCH TRIPLE 70 mA 70 V / 200 MW SOT363	BAS70TW-7-F	
5	1	D58	75 V	DIODE SW 150 mA 75 V SOD-323	1N4148WS-7-F	
6	2	D59, D64	150 mA	LED RED SGL 25 mA 0805	598-8110-107F	
7	3	D60, D61, D63	25 mA	LED GRN SGL 25 mA 0805	598-8170-107F	
Capacitors						
8	2	C1, C3	0.1 μ F	CAP CER 0.1 μ F 50 V 10% X7R 0805	C0805C104K5RAC	
9	1	C2	100 μ F	CAP ALEL 100 μ F 50 V 20% AEC-Q200 RADIAL SMT	MAL214699104E3	
10	2	C4, C5	0.033 μ F	CAP CER 0.033 μ F 50 V 10% X7R 0805	0805C333KAT2A	
11	1	C7	0.33	CAP CER 0.33 μ F 50 V 10% X7R 0603	C1608X7R1H334K080AC	
12	1	C8	0.1 μ F	CAP CER 0.1 μ F 16 V 10% X7R AEC-Q200 0603	GCM188R71C104KA37D	
13	1	C9	0.047 μ F	CAP CER 0.047 μ F 25 V 10% X7R 0603	C0603X7R250-473KNE	
Resistors						
14	1	R1	1.0 M Ω	RES 1 M Ω 1/4 W 1% AEC-Q200 0603	CRCW06031M00FKEAHP	
15	1	R2	47 k Ω	RES MF 47 k Ω 1/10 W 1.0% AEC-Q200 0603	CRCW060347K0FKEA	
16	1	R10	10 k Ω	RES MF 10 k Ω 1/10 W 5% AEC-Q200 0603	ERJ-3GEYJ103V	
17	4	R18, R188, R192, R193	0 Ω	RES MF 0 Ω 1/10 W -- 0603	CRCW06030000Z0EA	
18	1	R202	200 Ω	RES MF 200 Ω 1/10 W 1% 0603	RK73H1JTDD2000F	
19	2	R203, R204	1.0 K Ω	RES MF 1.0 K Ω 1/10 W 1% 0603	AR03FTNX1001	
20	4	R206, R207, R208, R209	4.70 K Ω	RES MF 4.70 K Ω 1/10 W 1% 0603	RK73H1JTDD4701F	

Table 12. Bill of materials ⁽¹⁾ (continued)

Item	Qty	Schematic Label	Value	Value/Description	Part Number	Assy Opt
Switches, Connectors, Jumpers and Test Points						
21	16	IN1, GND1, IN2, GND2, GND3, VPWR, VDDQ, VDD, SCLK, MOSI, MISO, GND, FS_B, ENBL, DIS, CS_B		TEST POINT BLACK 40 MIL DRILL 180 MIL TH 109L	5001	
22	11	J1, J2, J3, J4, J5, J6, J7, J8, J14, J17		HDR 1X3 TH 100 MIL SP 374H AU	826629-3	
23	1	J10		HDR 2X10 TH 100 MIL CTR 330H AU 100L	TSW-110-07-S-D	
24	4	J11, J15, J18, J19, J26		HDR 1X2 TH 100 MIL SP 378H AU 130L	826629-2	
25	2	J20, J21		CON 1X2 TB TH 5.08 MM 543H SN 138L	20020316-H021B01LF	
26	1	J23		HDR 2X6 TH 100 MIL CTR 330H AU	TSW-106-07-S-D	
27	2	J24, J25		HDR 2X8 TH 100 MIL CTR 330H AU	TSW-108-07-G-D	
28	1	Q1		TRAN NMOS PWR 30 A 55 V AEC-Q101 TO252	IPD30N06S2-15	
29	1	Q3		TRAN NPN DRIVER 500 mA 80 V AEC-Q101 SOT23	SMMBTA06LT1G	

Notes

1. NXP does not assume liability, endorse, or warrant components from external manufacturers are referenced in circuit drawings or tables. While NXP offers component recommendations in this configuration, it is the customer's responsibility to validate their application.
2. **Critical components.** For critical components, it is vital to use the manufacturer listed.

9 Accessory item bill of materials

Table 13. Bill of materials ⁽³⁾

Item	Qty	Part Number	Description
1	1	FRDM-KL25Z	NXP Freedom Development Platform for Kinetis KL14/15/24/25 MCUs

Notes

3. NXP does not assume liability, endorse, or warrant components from external manufacturers are referenced in circuit drawings or tables. While NXP offers component recommendations in this configuration, it is the customer's responsibility to validate their application.

10 References

Following are URLs where you can obtain information on related NXP products and application solutions:

NXP.com support pages	Description	URL
FRDM-HB2000-EVM	Tool Summary Page	www.nxp.com/FRDM-HB2000-EVM
MC33HB2000	Product Summary Page	www.nxp.com/MC33HB2000
FRDM-KL25Z	Tool Summary Page	www.nxp.com/webapp/sps/site/prod_summary.jsp?code=FRDM-KL25Z
SPIGen	Software	www.nxp.com/SPIGEN

10.1 Support

Visit www.nxp.com/support for a list of phone numbers within your region.

10.2 Warranty

Visit www.nxp.com/warranty to submit a request for tool warranty.

11 Revision history

Revision	Date	Description of Changes
1.0	3/2016	• Initial release



How to Reach Us:

Home Page:

[NXP.com](http://www.nxp.com)

Web Support:

<http://www.nxp.com/support>

Information in this document is provided solely to enable system and software implementers to use NXP products.

There are no expressed or implied copyright licenses granted hereunder to design or fabricate any integrated circuits based on the information in this document. NXP reserves the right to make changes without further notice to any products herein.

NXP makes no warranty, representation, or guarantee regarding the suitability of its products for any particular purpose, nor does NXP assume any liability arising out of the application or use of any product or circuit, and specifically disclaims any and all liability, including without limitation, consequential or incidental damages. "Typical" parameters that may be provided in NXP data sheets and/or specifications can and do vary in different applications, and actual performance may vary over time. All operating parameters, including "typicals," must be validated for each customer application by the customer's technical experts. NXP does not convey any license under its patent rights nor the rights of others. NXP sells products pursuant to standard terms and conditions of sale, which can be found at the following address:

<http://www.nxp.com/terms-of-use.html>.

NXP, the NXP logo, Freescale, the Freescale logo, SafeAssure, the SafeAssure logo and SMARTMOS are trademarks of NXP B.V. All other product or service names are the property of their respective owners. All rights reserved.

© 2016 NXP B.V.

Document Number: KTFRDMHB2000EVMUG

Rev. 1.0

3/2016



Mouser Electronics

Authorized Distributor

Click to View Pricing, Inventory, Delivery & Lifecycle Information:

[NXP:](#)

[FRDM-HB2000-EVM](#)