

NOTES: UNLESS OTHERWISE SPECIFIED

1. VENDOR TO INSPECT WIRE TERMINATIONS AND POSITION TO COLOR PRIOR TO ASSY.
- 2 SECURELY FASTEN LABELS. LABELS MUST NOT MOVE OR ROTATE. SEE TABULATION CHART FOR MARKINGS.
- 3 WRAP THREE WIRES THROUGH TOROID CORE 5 EA FULL TURNS AND COVER WITH OVERMOLD AS SHOWN IN APPROX. LOCATION.
- 4 SHIELD TO BE CONNECTED TO GND WIRE. DO NOT ROUTE THROUGH TOROID. COVER WITH OVERMOLD.

REVISIONS			
REV	DESCRIPTION	DATE	APPROVED
A	INITIAL RELEASE ECO 5236	8/25/05	R.HAZELWOOD
B	REVISED SHIELD DET- ECO 5268	2/3/06	
C	CABLE MATL CHG - ECO 5268	2/3/06	
D	CABLE MATL/CLAMP CHG - ECO 5725	7/2/08	J.KORDIK

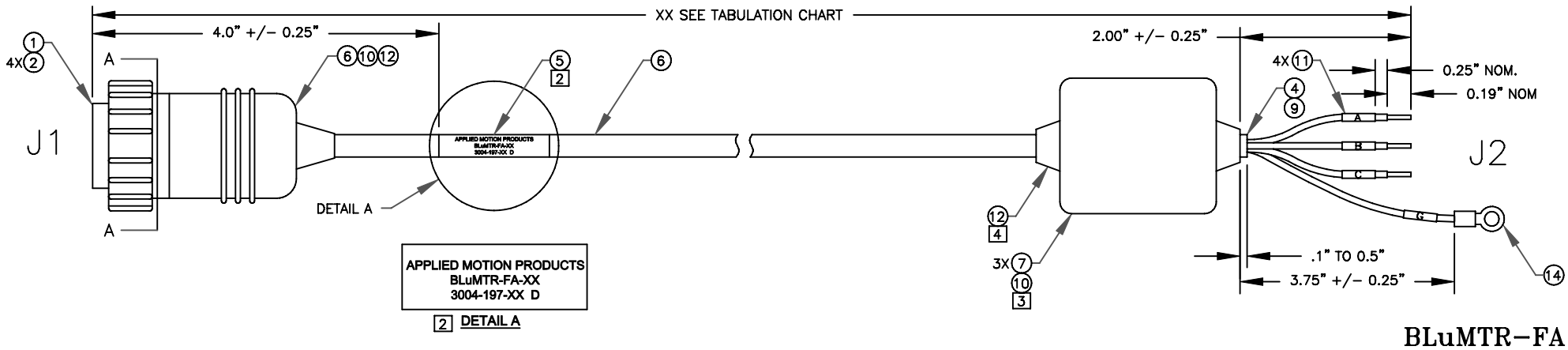

BLuMTR-FA

2] TABULATION CHART

XX	LENGTH TABLE	PART NUMBER/REV	CABLE
XX	LENGTH	-	-
04	48.0" +/- 2.0"	3004-197-04 D	BLUMTR-FA-04
10	120.0" +/- 3.0"	3004-197-10 D	BLUMTR-FA-10
20	240.0" +/- 4.0"	3004-197-20 D	BLUMTR-FA-20
XX	XX +/- 1.5%	-	-

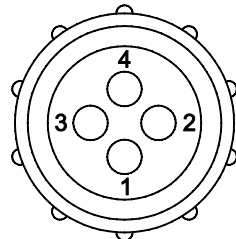

VIEW A - A
VIEW FROM TERMINATION SIDE

WIRELIST		
FROM	COLOR	TO J2
J1-1	RED	A
J1-2	WHITE	B
J1-3	BLACK	C
J1-4	GREEN / YELLOW	G

BILL OF MATERIALS					
ITEM	PART NUMBER	DESCRIPTION	QTY	UOM	MFR
1	206060-1	PLUG, CPC 4 POSITION, SHELL SIZE 11	1	EA	AMP
2	66100-8 OR 66101-3	SOCKET, CONTACT 18 - 16 AWG	4	EA	AMP
3					
4	FIT-221-1/4-BLK	SHRINK TUBING, 1/4, BLK	1	IN	ALPHA OR EQUIV.
5	LAT-27-361	LABEL, 1.875" X 3.167"	1	EA	BRADY
6	666-2122	CABLE, 6 CONDUCTOR SHIELDED, PVC JACKET	XX	FT	WASATCH CABLE
7	ZJ-42507-TC	TOROID FERRITE CORE	3	EA	MAGI
8					
9	EPS-300-1/2	SHRINK TUBING, 1/2 ID, ADHESIVE, BLK	.5	IN	3M OR EQUIV.
10	CD-02698	OVERMOLD, BLUE (PANTONE 7462U), GLOSSY	AR	LB	RIMTEC OR EQUIV.
11	LAT-15-361-1	LABEL, 0.50" X 0.75"	4	EA	BRADY
12	3779-PG 1.0" X 3.0"	HOT MELT	AR	LB	3M OR EQUIV.
13					
14	34105	RING TERMINAL, 22-16 AWG, #8 STUD, UNINSULATED	1	EA	AMP OR EQUIV.
15					

TOLERANCES		THIRD ANGLE PROJECTION	
DECIMALS: MM (INCH) X.XXX = ±0.01 (.005) X.XX = ±0.10 (.010) X.X = ±0.20 (.020)			
ANGLES: MACH. = ±.5° CHAM. = ±5°		APPROVALS DRAWN <i>R.BARRICK</i> CHECKED APPROVED	DATE 3/6/01
COMPUTER DATA BASE DRAWING			
ALPHA MOTOR POWER CABLE EXTENSION			
B	DWG NO.	3004-197	REV D
SCALE: FULL		SHEET 1 OF 1	

Mouser Electronics

Authorized Distributor

Click to View Pricing, Inventory, Delivery & Lifecycle Information:

[Applied Motion:](#)

[BluMTR-FA-04](#)