

EP2 SERIES

FEATURES

- Twin relay for motor and solenoid reversible control
- 50% less relay space than conventional two relays
- Contact switching current of 30 A max.
- High performance and productivity by unique symmetrical structure
- Flux tight housing
- Delivered in stick-tube for automatic insertion machine
- Washable type available



PART NUMBERS AND COIL RATINGS

At 20°C (68°F)

| Part Number | | Nominal Voltage (Vdc) | Coil Resistance ($\Omega \pm 10\%$) | Nominal Current (mA) | Must Operate Voltage (Vdc) | Must Release Voltage (Vdc) | Nominal Operate Power (W) |
|---------------|---------------|-----------------------|---------------------------------------|----------------------|----------------------------|----------------------------|---------------------------|
| H bridge Type | Separate Type | | | | | | |
| EP2-3N1S | EP2-3N1ST | 12 | 225 | 53.3 | 6.5 | 0.9 | 0.64 |
| EP2-3N2S | EP2-3N2ST | 12 | 225 | 53.3 | 7.0 | 0.9 | 0.64 |
| EP2-3N3S | EP2-3N3ST | 12 | 225 | 53.3 | 7.5 | 0.9 | 0.64 |
| EP2-4N3S | EP2-4N3ST | 12 | 300 | 40.0 | 7.5 | 0.9 | 0.48 |
| EP2-4N4S | EP2-4N4ST | 12 | 300 | 40.0 | 8.0 | 0.9 | 0.48 |
| EP2-4N5S | EP2-4N5ST | 12 | 300 | 40.0 | 8.5 | 0.9 | 0.48 |

PART NUMBER SYSTEM

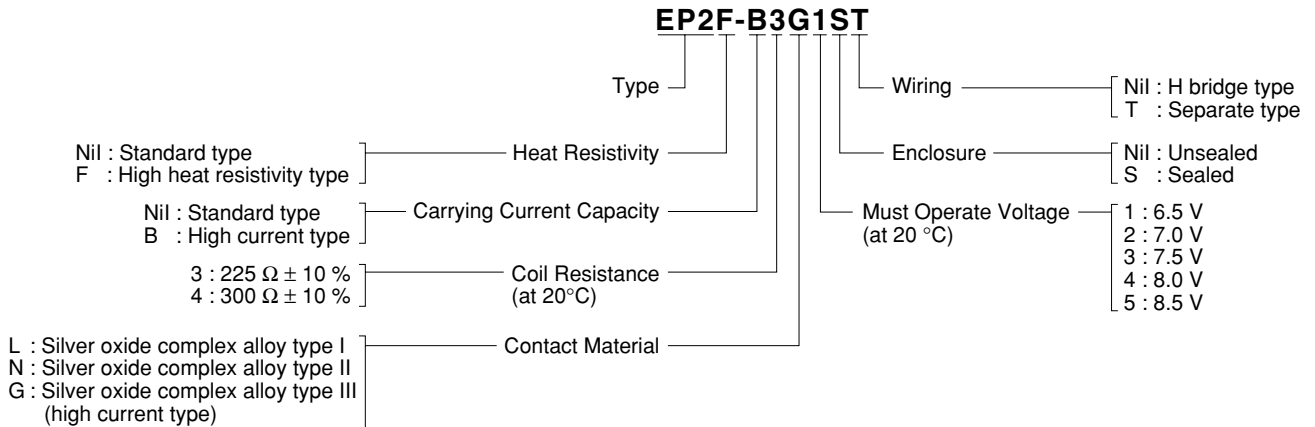
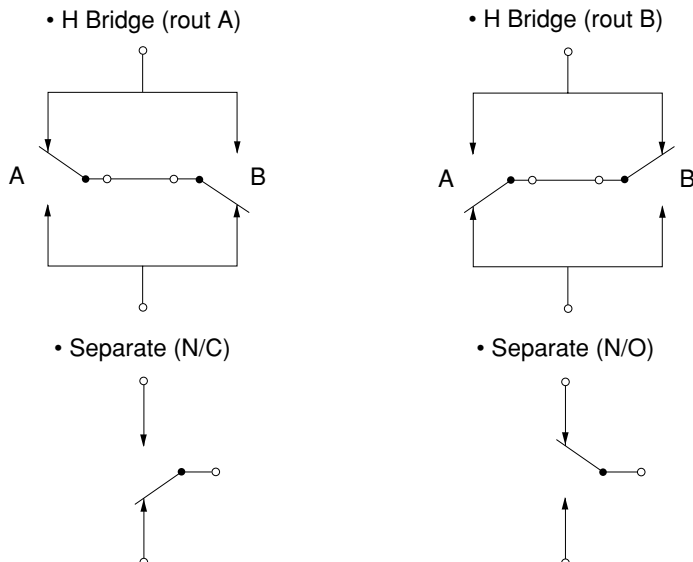
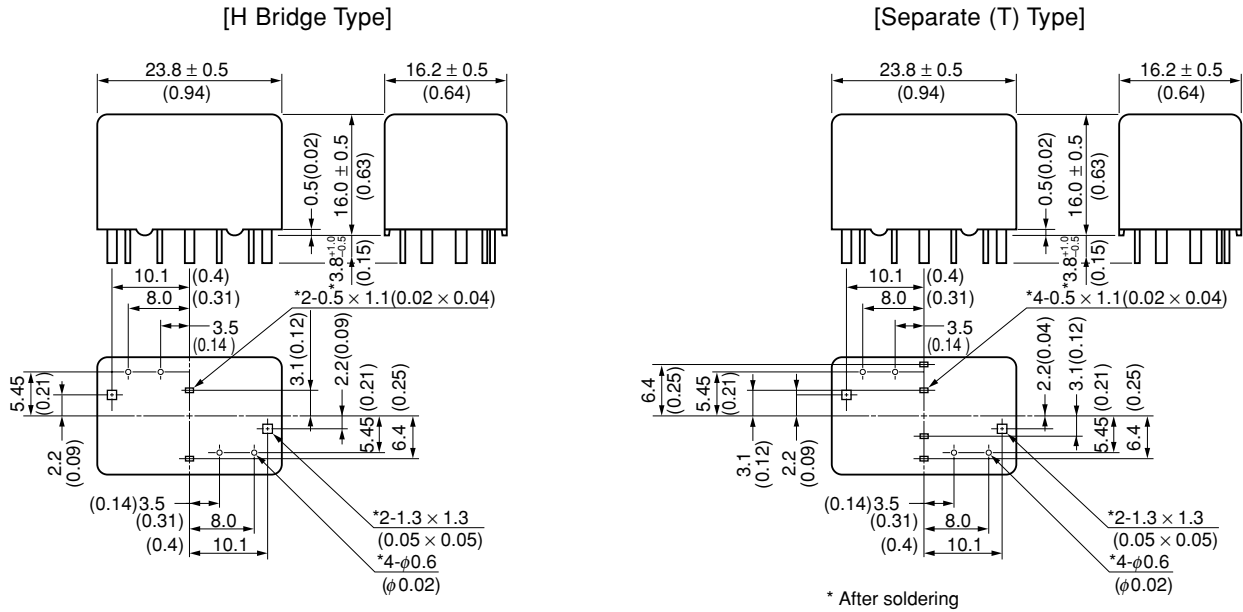

Figure 1 Contact Resistance*



DIMENSIONS mm (inch)



PCB PAD LAYOUT and SCHEMATICS (bottom view) mm (inch)

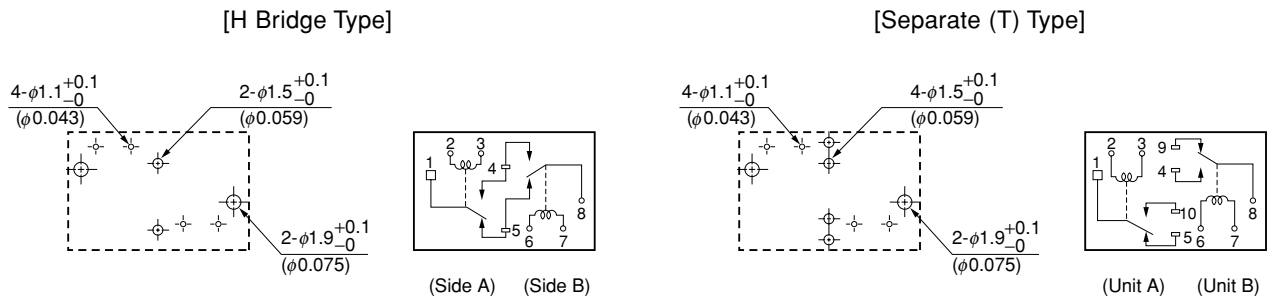

SPECIFICATIONS

At 20°C (68°F)

| Items | Specification | |
|--|--|--|
| | EP2- (Standard) | EP2-B (High Current) |
| Contact Form | 1 Form c × 2 (H Bridge Type or Separate Type) | |
| Contact Material | Silver oxide complex alloy (Special types available) | |
| Contact Resistance (* figure 1) (measured by voltage drop at 6Vdc, 7A) | H Bridge (rout A): 10.7 mΩ typ. H Bridge (rout B): 10.4 mΩ typ. Separate (N/C): 5.2 mΩ typ. Separate (N/O): 5.2 mΩ typ. | H Bridge (rout A): 6.7 mΩ typ. H Bridge (rout B): 6.4 mΩ typ. Separate (N/C): 3.2 mΩ typ. Separate (N/O): 3.2 mΩ typ. |
| Contact Switching Voltage | 16 Vdc max. 5 Vdc min. | |
| Contact Switching Current | 30A max. (at 16 Vdc) 1A min. | |
| Contact Carrying Current (2 minutes max.) | 25A (12 Vdc, 20°C) 20A (12 Vdc, 85°C) | 30A (12Vdc, 20°C) 25A (12Vdc, 85°C) |
| Operate Time | Approx. 5 ms (at 12 Vdc) | |
| Release Time | Approx. 7 ms (at 12 Vdc), with diode | |
| Nominal Operate Power | 0.48 W/0.64 W (at 12 Vdc) | |
| Insulation Resistance | 100 MΩ min. at 500 Vdc, Initial | |
| Breakdown Voltage | 500 Vac min. for 1 minute, Initial | |
| Shock Resistance | 98 m/s ² min. (misoperating) | |
| Vibration Resistance | 10 to 300 Hz, 43 m/s ² min. (misoperating) | |
| Ambient Temperature | -40°C to +85°C (-40°F to +185°F) | |
| Coil Temperature Rise | 50°C/W (Contact Carrying Current 0 A) | |
| Life Expectancy | Mechanical | 1 × 10 ⁶ operations |
| | Electrical | 1 × 10 ⁵ operations (at 14 Vdc, Motor Load 25 A/5 A) |
| Weight | Approx. 15 g | |

No part of this document may be copied or reproduced in any form or by any means without the prior written consent of NEC/TOKIN Corporation. NEC/TOKIN Corporation assumes no responsibility for any errors which may appear in this document.

NEC/TOKIN Corporation does not assume any liability for infringement of patents, copyrights or other intellectual property rights of third parties by or arising from use of a device described herein or any other liability arising from use of such device. No license, either express, implied or otherwise, is granted under any patents, copyrights or other intellectual property rights of NEC/TOKIN Corporation or others.

While NEC/TOKIN Corporation has been making continuous effort to enhance the reliability of its electronic components, the possibility of defects cannot be eliminated entirely. To minimize risks of damage or injury to persons or property arising from a defect in an NEC/TOKIN electronic component, customers must incorporate sufficient safety measures in its design, such as redundancy, fire-containment, and anti-failure features. NEC/TOKIN devices are classified into the following three quality grades:

"Standard," "Special," and "Specific". The Specific quality grade applies only to devices developed based on a customer designated "quality assurance program" for a specific application. The recommended applications of a device depend on its quality grade, as indicated below. Customers must check the quality grade of each device before using it in a particular application.

Standard: Computers, office equipment, communications equipment, test and measurement equipment, audio and visual equipment, home electronic appliances, machine tools, personal electronic equipment and industrial robots

Special: Transportation equipment (automobiles, trains, ships, etc.), traffic control systems, anti-disaster systems, anti-crime systems, safety equipment and medical equipment (not specifically designed for life support)

Specific: Aircrafts, aerospace equipment, submersible repeaters, nuclear reactor control systems, life support systems or medical equipment for life support, etc.

The quality grade of NEC/TOKIN devices is "Standard" unless otherwise specified in NEC/TOKIN's Data Sheets or Data Books. If customers intend to use NEC/TOKIN devices for applications other than those specified for Standard quality grade, they should contact an NEC/TOKIN sales representative in advance.

(Note)

- (1) "NEC/TOKIN" as used in this statement means NEC/TOKIN Corporation and also includes its majority-owned subsidiaries.
- (2) "NEC/TOKIN electronic component products" means any electronic component product developed or manufactured by or for NEC/TOKIN (as defined above).

Mouser Electronics

Authorized Distributor

Click to View Pricing, Inventory, Delivery & Lifecycle Information:

[NEC:](#)

[EP2-3N1S](#)