

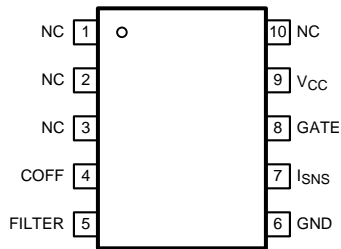



These devices have limited built-in ESD protection. The leads should be shorted together or the device placed in conductive foam during storage or handling to prevent electrostatic damage to the MOS gates.



**Figure 1. 10-Pin VSSOP (Top View)**  
See DGS Package

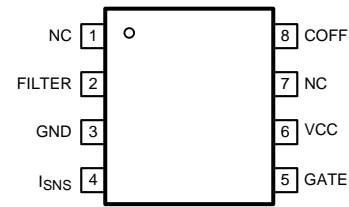

**Figure 2. 8-Lead SOIC (Top View)**  
See D Package

### PIN DESCRIPTIONS

VSSOP	SOIC	Name	Description
1	1	NC	No internal connection. Leave this pin open.
2		NC	No internal connection. Leave this pin open.
3		NC	No internal connection. Leave this pin open.
4	8	COFF	OFF time setting pin. A user set current and capacitor connected from the output to this pin sets the constant OFF time of the switching controller.
5	2	FILTER	Filter input. A low pass filter tied to this pin can filter a PWM dimming signal to supply a DC voltage to control the LED current. Can also be used as an analog dimming input. If not used for dimming connect a 0.1µF capacitor from this pin to ground.
6	3	GND	Circuit ground connection.
7	4	ISNS	LED current sense pin. Connect a resistor from main switching MOSFET source, ISNS to GND to set the maximum LED current.
8	5	GATE	Power MOSFET driver pin. This output provides the gate drive for the power switching MOSFET of the buck controller.
9	6	V <sub>CC</sub>	Input voltage pin. This pin provides the power for the internal control circuitry and gate driver.
10	7	NC	No internal connection. Leave this pin open.

### ABSOLUTE MAXIMUM RATINGS <sup>(1)</sup>

If Military/Aerospace specified devices are required, contact the Texas Instruments Sales Office/Distributors for availability and specifications.

	VALUE / UNITS
V <sub>CC</sub> and GATE to GND	–0.3V to +14V
ISNS to GND	–0.3V to +2.5V
FILTER and COFF to GND	–0.3V to +7.0V
COFF Input Current	60mA
Continuous Power Dissipation <sup>(2)</sup>	Internally Limited
ESD Susceptibility; HBM <sup>(3)</sup>	
Junction Temperature (T <sub>J-MAX</sub> )	150°C
Storage Temperature Range	–65°C to +150°C
Maximum Lead Temperature Range (Soldering)	260°C

- (1) Absolute maximum ratings are limits beyond which damage to the device may occur. Operating Ratings are conditions for which the device is intended to be functional, but device parameter specifications may not be guaranteed. For specifications and test conditions, see the Electrical Characteristics. All voltages are with respect to the potential at the GND pin, unless otherwise specified.
- (2) Internal thermal shutdown circuitry protects the device from permanent damage. Thermal shutdown engages at T<sub>J</sub> = 165°C (typ.) and disengages at T<sub>J</sub> = 145°C (typ.).
- (3) Human Body Model, applicable std. JESD22-A114-C.

**RECOMMENDED OPERATING CONDITIONS**

	VALUE / UNITS
V <sub>CC</sub>	8.0V to 13V
Junction Temperature	-40°C to +125°C

**ELECTRICAL CHARACTERISTICS**

Limits in standard type face are for T<sub>J</sub> = 25°C and those with **boldface type** apply over the full **Operating Temperature Range** (T<sub>J</sub> = -40°C to +125°C). Minimum and Maximum limits are specified through test, design, or statistical correlation. Typical values represent the most likely parametric norm at T<sub>J</sub> = 25°C, and are provided for reference purposes only. Unless otherwise stated the following conditions apply: V<sub>CC</sub> = 12V.

Symbol	Parameter	Conditions	Min	Typ	Max	Units
<b>V<sub>CC</sub> SUPPLY</b>						
I <sub>VCC</sub>	Operating supply current			1.58	<b>2.25</b>	mA
V <sub>CC-UVLO</sub>	Rising threshold			7.4	<b>7.7</b>	V
	Falling threshold		<b>6.0</b>	6.4		
	Hysteresis			1		
<b>COFF</b>						
V <sub>COFF</sub>	Time out threshold		<b>1.22</b> <b>5</b>	1.276	<b>1.327</b>	V
R <sub>COFF</sub>	Off timer sinking impedance			33	<b>60</b>	Ω
t <sub>COFF</sub>	Restart timer			180		μs
<b>CURRENT LIMIT</b>						
V <sub>ISNS</sub>	ISNS limit threshold		<b>1.17</b> <b>4</b>	1.269	<b>1.364</b>	V
t <sub>ISNS</sub>	Leading edge blanking time			125		ns
	Current limit reset delay			180		μs
	ISNS limit to GATE delay	ISNS = 0 to 1.75V step		33		ns
<b>CURRENT SENSE COMPARATOR</b>						
V <sub>FILTER</sub>	FILTER open circuit voltage		<b>720</b>	750	<b>780</b>	mV
R <sub>FILTER</sub>	FILTER impedance			1.12		MΩ
V <sub>OS</sub>	Current sense comparator offset voltage		<b>-4.0</b>	0.1	<b>4.0</b>	mV
<b>GATE DRIVE OUTPUT</b>						
V <sub>DRVH</sub>	GATE high saturation	I <sub>GATE</sub> = 50 mA		0.24	<b>0.50</b>	V
V <sub>DRVL</sub>	GATE low saturation	I <sub>GATE</sub> = 100 mA		0.22	<b>0.50</b>	
I <sub>DRV</sub>	Peak source current	GATE = V <sub>CC</sub> /2		-0.77		A
	Peak sink current	GATE = V <sub>CC</sub> /2		0.88		
t <sub>DV</sub>	Rise time	C <sub>load</sub> = 1 nF		15		ns
	Fall time	C <sub>load</sub> = 1 nF		15		
<b>THERMAL SHUTDOWN</b>						
T <sub>SD</sub>	Thermal shutdown temperature	See <sup>(1)</sup>		165		°C
	Thermal shutdown hysteresis			20		
<b>THERMAL SPECIFICATION</b>						
R <sub>θJA</sub>	VSSOP junction to ambient			124		°C/W
R <sub>θJC</sub>	VSSOP junction to case			76		

- (1) Junction-to-ambient thermal resistance is highly application and board-layout dependent. In applications where high maximum power dissipation exists, special care must be paid to thermal dissipation issues in board design. In applications where high power dissipation and/or poor package thermal resistance is present, the maximum ambient temperature may have to be derated. Maximum ambient temperature (T<sub>A-MAX</sub>) is dependent on the maximum operating junction temperature (T<sub>J-MAX-OP</sub> = 125°C), the maximum power dissipation of the device in the application (P<sub>D-MAX</sub>), and the junction-to ambient thermal resistance of the part/package in the application (R<sub>θJA</sub>), as given by the following equation: T<sub>A-MAX</sub> = T<sub>J-MAX-OP</sub> - (R<sub>θJA</sub> × P<sub>D-MAX</sub>).

TYPICAL PERFORMANCE CHARACTERISTICS

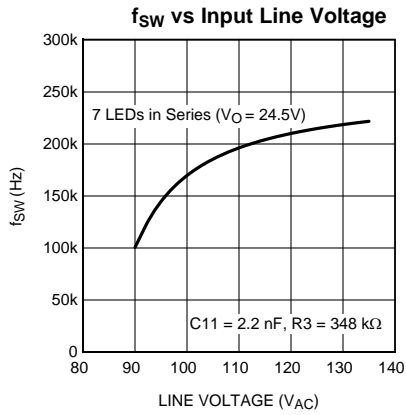

Figure 3.

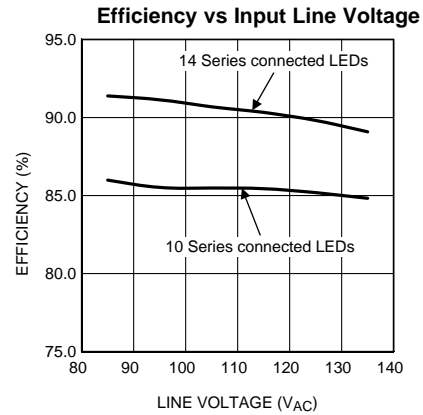

Figure 4.

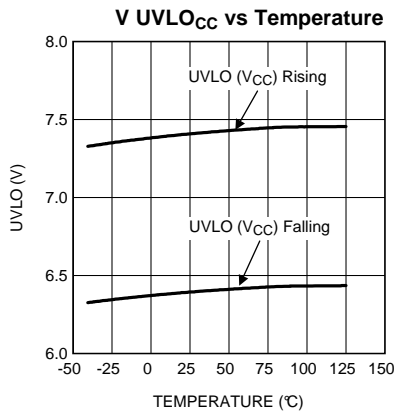

Figure 5.

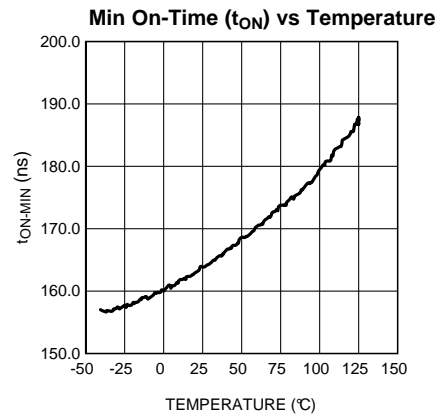

Figure 6.

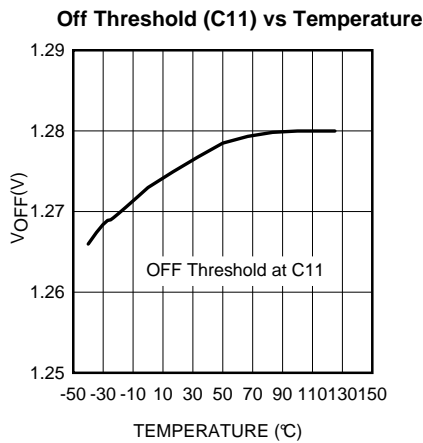

Figure 7.

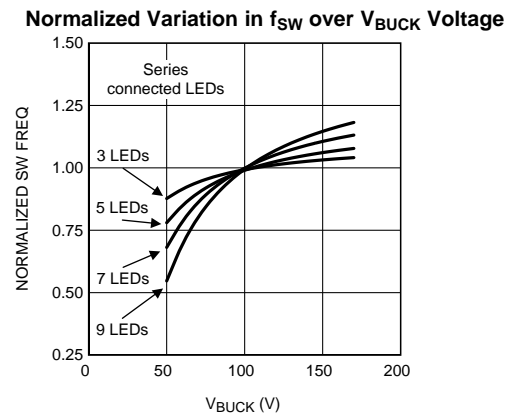
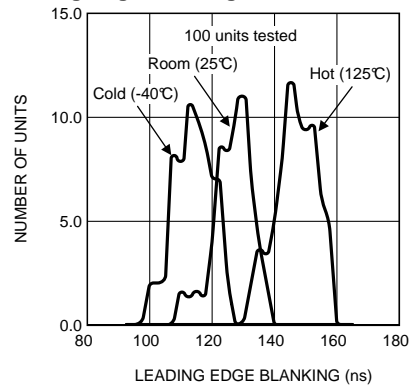

Figure 8.

**TYPICAL PERFORMANCE CHARACTERISTICS (continued)**

**Leading Edge Blanking Variation Over Temperature**



**Figure 9.**

SIMPLIFIED INTERNAL BLOCK DIAGRAM

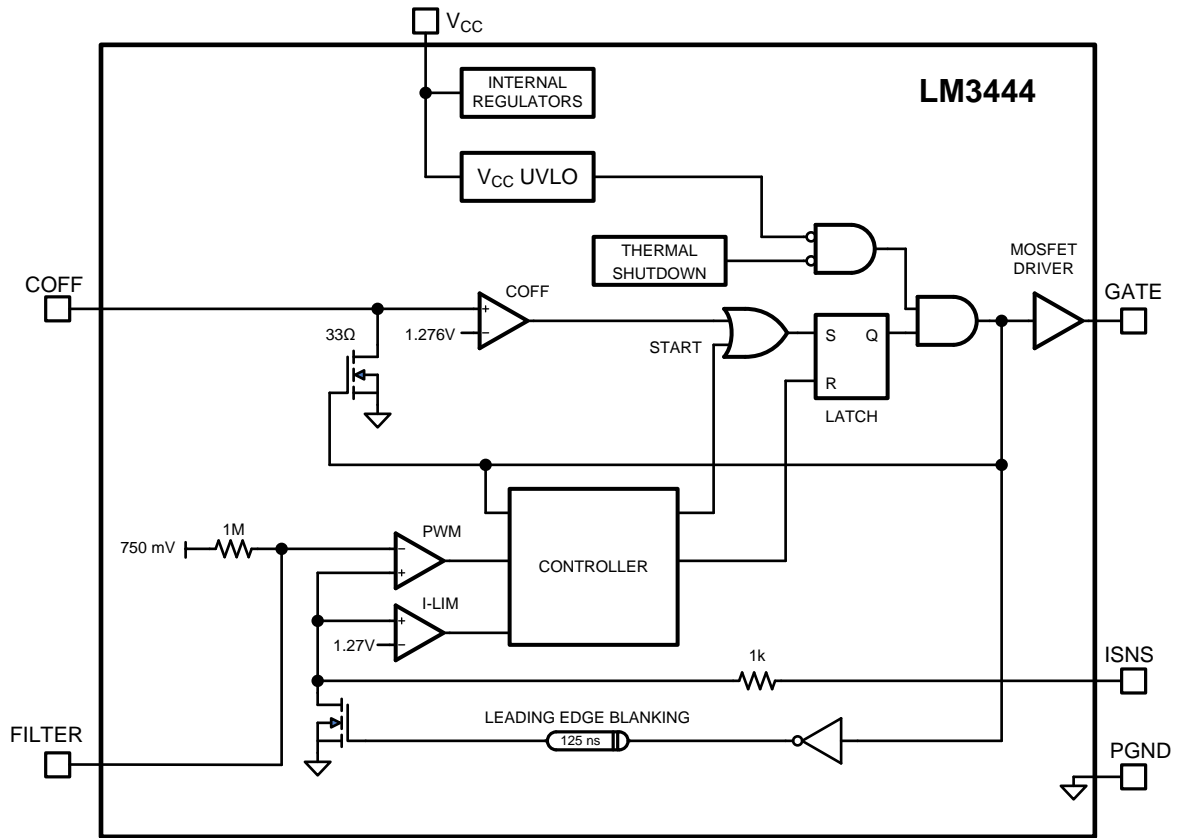

Figure 10. Simplified Block Diagram

## APPLICATION INFORMATION

### FUNCTIONAL DESCRIPTION

The LM3444 contains all the necessary circuitry to build a line-powered (mains powered) constant current LED driver.

### Theory of Operation

Refer to [Figure 11](#) below which shows the LM3444 along with basic external circuitry.

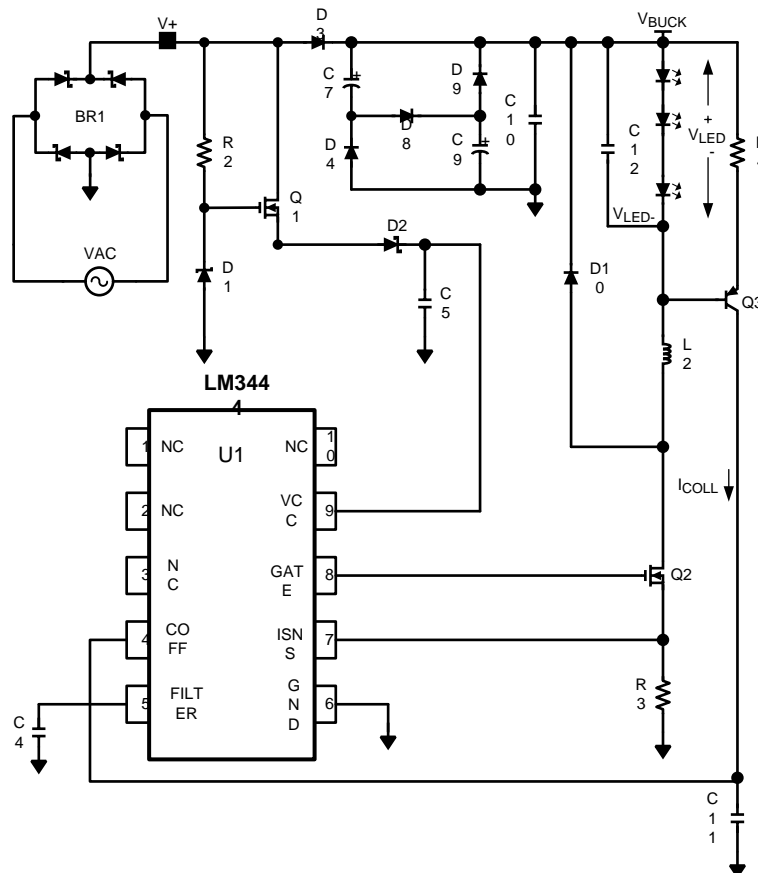

Figure 11. LM3444 Schematic

### VALLEY-FILL CIRCUIT

$V_{BUCK}$  supplies the power which drives the LED string. Diode D3 allows  $V_{BUCK}$  to remain high while  $V+$  cycles on and off.  $V_{BUCK}$  has a relatively small hold capacitor C10 which reduces the voltage ripple when the valley fill capacitors are being charged. However, the network of diodes and capacitors shown between D3 and C10 make up a "valley-fill" circuit. The valley-fill circuit can be configured with two or three stages. The most common configuration is two stages. [Figure 12](#) illustrates a two and three stage valley-fill circuit.

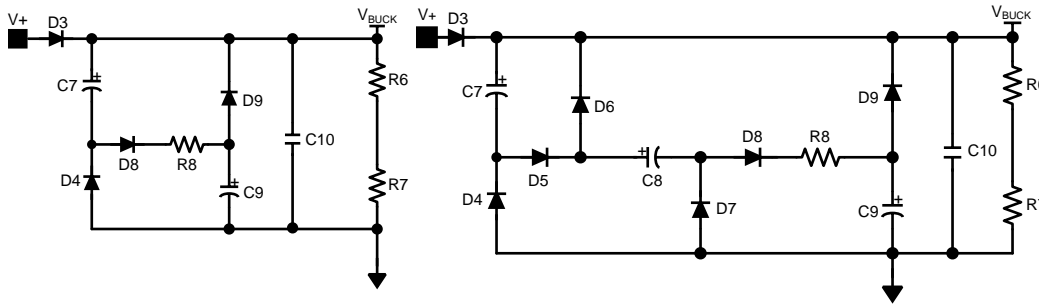

Figure 12. Two and Three Stage Valley Fill Circuit

The valley-fill circuit allows the buck regulator to draw power throughout a larger portion of the AC line. This allows the capacitance needed at  $V_{BUCK}$  to be lower than if there were no valley-fill circuit, and adds passive power factor correction (PFC) to the application.

**VALLEY-FILL OPERATION**

When the “input line is high”, power is derived directly through D3. The term “input line is high” can be explained as follows. The valley-fill circuit charges capacitors C7 and C9 in series (Figure 13) when the input line is high.

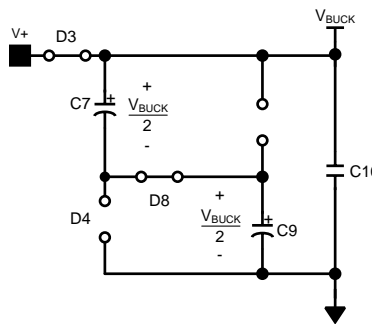

Figure 13. Two stage Valley-Fill Circuit when AC Line is High

The peak voltage of a two stage valley-fill capacitor is:

$$V_{VF-CAP} = \frac{V_{AC-RMS}\sqrt{2}}{2} \tag{1}$$

As the AC line decreases from its peak value every cycle, there will be a point where the voltage magnitude of the AC line is equal to the voltage that each capacitor is charged. At this point diode D3 becomes reversed biased, and the capacitors are placed in parallel to each other (Figure 14), and  $V_{BUCK}$  equals the capacitor voltage.

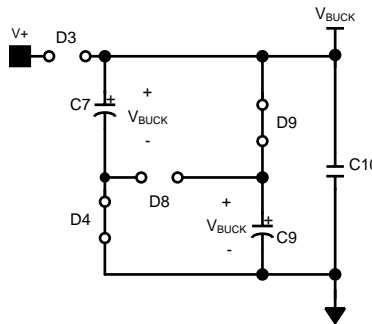

Figure 14. Two stage Valley-Fill Circuit when AC Line is Low



A three stage valley-fill circuit performs exactly the same as two-stage valley-fill circuit except now three capacitors are now charged in series, and when the line voltage decreases to:

$$V_{VF-CAP} = \frac{V_{AC-RMS}\sqrt{2}}{3} \quad (2)$$

Diode D3 is reversed biased and three capacitors are in parallel to each other.

The valley-fill circuit can be optimized for power factor, voltage hold up and overall application size and cost. The LM3444 will operate with a single stage or a three stage valley-fill circuit as well. Resistor R8 functions as a current limiting resistor during start-up, and during the transition from series to parallel connection. Resistors R6 and R7 are 1 MΩ bleeder resistors, and may or may not be necessary for each application.

## BUCK CONVERTER

The LM3444 is a buck controller that uses a proprietary constant off-time method to maintain constant current through a string of LEDs. While transistor Q2 is on, current ramps up through the inductor and LED string. A resistor R3 senses this current and this voltage is compared to the reference voltage at FILTER. When this sensed voltage is equal to the reference voltage, transistor Q2 is turned off and diode D10 conducts the current through the inductor and LEDs. Capacitor C12 eliminates most of the ripple current seen in the inductor. Resistor R4, capacitor C11, and transistor Q3 provide a linear current ramp that sets the constant off-time for a given output voltage.

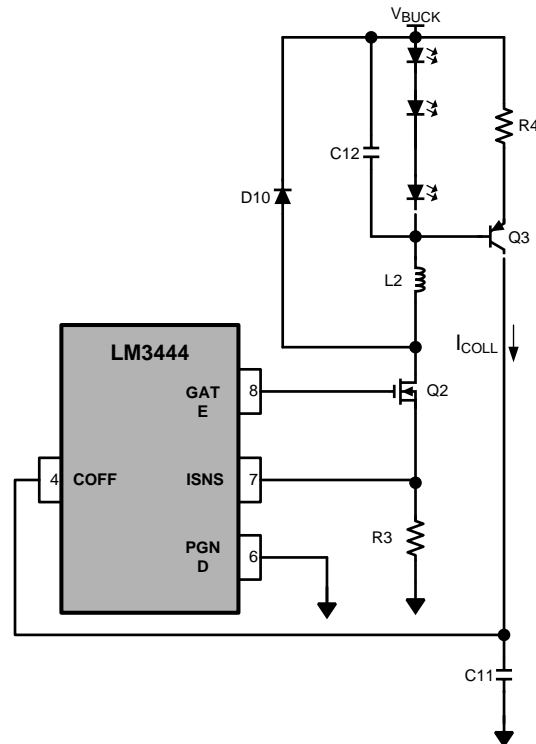

Figure 15. LM3444 Buck Regulation Circuit

## OVERVIEW OF CONSTANT OFF-TIME CONTROL

A buck converter's conversion ratio is defined as:

$$\frac{V_O}{V_{IN}} = D = \frac{t_{ON}}{t_{ON} + t_{OFF}} = t_{ON} \times f_{SW} \quad (3)$$

Constant off-time control architecture operates by simply defining the off-time and allowing the on-time, and therefore the switching frequency, to vary as either  $V_{IN}$  or  $V_O$  changes. The output voltage is equal to the LED string voltage ( $V_{LED}$ ), and should not change significantly for a given application. The input voltage or  $V_{BUCK}$  in this analysis will vary as the input line varies. The length of the on-time is determined by the sensed inductor current through a resistor to a voltage reference at a comparator. During the on-time, denoted by  $t_{ON}$ , MOSFET switch Q2 is on causing the inductor current to increase. During the on-time, current flows from  $V_{BUCK}$ , through the LEDs, through L2, Q2, and finally through R3 to ground. At some point in time, the inductor current reaches a maximum ( $I_{L2-PK}$ ) determined by the voltage sensed at R3 and the ISNS pin. This sensed voltage across R3 is compared against the voltage of FILTER, at which point Q2 is turned off by the controller.

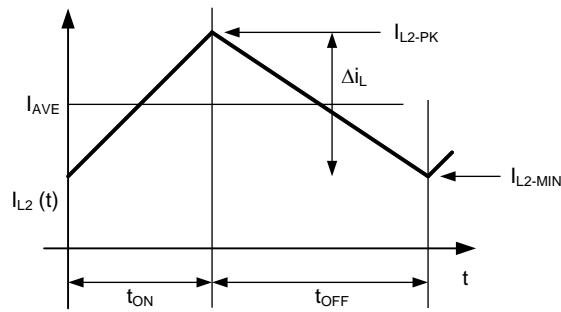

**Figure 16. Inductor Current Waveform in CCM**

During the off-period denoted by  $t_{OFF}$ , the current through L2 continues to flow through the LEDs via D10.

## THERMAL SHUTDOWN

Thermal shutdown limits total power dissipation by turning off the output switch when the IC junction temperature exceeds 165°C. After thermal shutdown occurs, the output switch doesn't turn on until the junction temperature drops to approximately 145°C.

## Design Guide

### DETERMINING DUTY-CYCLE (D)

Duty cycle (D) approximately equals:

$$\frac{V_{LED}}{V_{BUCK}} = D = \frac{t_{ON}}{t_{ON} + t_{OFF}} = t_{ON} \times f_{SW} \quad (4)$$

With efficiency considered:

$$\frac{1}{\eta} \times \frac{V_{LED}}{V_{BUCK}} = D \quad (5)$$

For simplicity, choose efficiency between 75% and 85%.

### CALCULATING OFF-TIME

The "Off-Time" of the LM3444 is set by the user and remains fairly constant as long as the voltage of the LED stack remains constant. Calculating the off-time is the first step in determining the switching frequency of the converter, which is integral in determining some external component values.

PNP transistor Q3, resistor R4, and the LED string voltage define a charging current into capacitor C11. A constant current into a capacitor creates a linear charging characteristic.

$$i = C \frac{dv}{dt} \quad (6)$$

Resistor R4, capacitor C11 and the current through resistor R4 ( $i_{COLL}$ ), which is approximately equal to  $V_{LED}/R4$ , are all fixed. Therefore,  $dv$  is fixed and linear, and  $dt$  ( $t_{OFF}$ ) can now be calculated.

$$t_{OFF} = C11 \times 1.276V \times \left( \frac{R4}{V_{LED}} \right) \quad (7)$$

Common equations for determining duty cycle and switching frequency in any buck converter:

$$f_{SW} = \frac{1}{t_{OFF} + t_{ON}}$$

$$D = \frac{t_{ON}}{t_{ON} + t_{OFF}} = \frac{V_{LED}}{V_{BUCK}}$$

$$D' = \frac{t_{OFF}}{t_{ON} + t_{OFF}} \quad (8)$$

Therefore:

$$f_{SW} = \frac{D}{t_{ON}}, \text{ and } f_{SW} = \frac{1 - D}{t_{OFF}} \quad (9)$$

With efficiency of the buck converter in mind:

$$\frac{V_{LED}}{V_{BUCK}} = \eta \times D \quad (10)$$

Substitute equations and rearrange:

$$f_{SW} = \frac{\left( 1 - \frac{1}{\eta} \times \frac{V_{LED}}{V_{BUCK}} \right)}{t_{OFF}} \quad (11)$$

Off-time, and switching frequency can now be calculated using the equations above.

### SETTING THE SWITCHING FREQUENCY

Selecting the switching frequency for nominal operating conditions is based on tradeoffs between efficiency (better at low frequency) and solution size/cost (smaller at high frequency).

The input voltage to the buck converter ( $V_{BUCK}$ ) changes with both line variations and over the course of each half-cycle of the input line voltage. The voltage across the LED string will, however, remain constant, and therefore the off-time remains constant.

The on-time, and therefore the switching frequency, will vary as the  $V_{BUCK}$  voltage changes with line voltage. A good design practice is to choose a desired nominal switching frequency knowing that the switching frequency will decrease as the line voltage drops and increase as the line voltage increases (Figure 17).

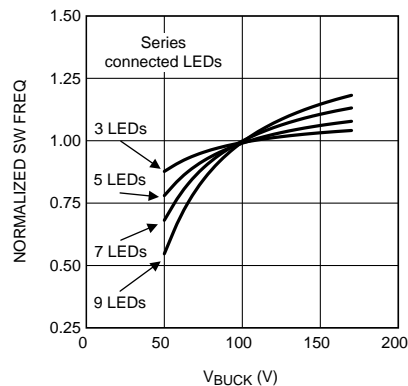

Figure 17. Graphical Illustration of Switching Frequency vs  $V_{BUCK}$

The off-time of the LM3444 can be programmed for switching frequencies ranging from 30 kHz to over 1 MHz. A trade-off between efficiency and solution size must be considered when designing the LM3444 application.

The maximum switching frequency attainable is limited only by the minimum on-time requirement (200 ns).

Worst case scenario for minimum on time is when  $V_{BUCK}$  is at its maximum voltage (AC high line) and the LED string voltage ( $V_{LED}$ ) is at its minimum value.

$$t_{ON(MIN)} = \left( \frac{1}{\eta} \times \frac{V_{LED(MIN)}}{V_{BUCK(MAX)}} \right) \frac{1}{f_{SW}} \quad (12)$$

The maximum voltage seen by the Buck Converter is:

$$V_{BUCK(MAX)} = V_{AC-RMS(MAX)} \times \sqrt{2} \quad (13)$$

## INDUCTOR SELECTION

The controlled off-time architecture of the LM3444 regulates the average current through the inductor (L2), and therefore the LED string current. The input voltage to the buck converter ( $V_{BUCK}$ ) changes with line variations and over the course of each half-cycle of the input line voltage. The voltage across the LED string is relatively constant, and therefore the current through R4 is constant. This current sets the off-time of the converter and therefore the output volt-second product ( $V_{LED} \times \text{off-time}$ ) remains constant. A constant volt-second product makes it possible to keep the ripple through the inductor constant as the voltage at  $V_{BUCK}$  varies.

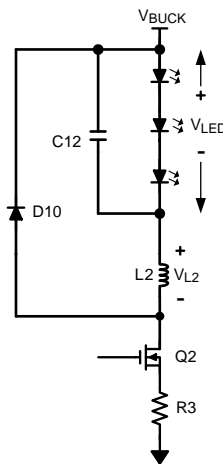

**Figure 18. LM3444 External Components of the Buck Converter**

The equation for an ideal inductor is:

$$v = L \frac{di}{dt} \quad (14)$$

Given a fixed inductor value, L, this equation states that the change in the inductor current over time is proportional to the voltage applied across the inductor.

During the on-time, the voltage applied across the inductor is,

$$V_{L(ON-TIME)} = V_{BUCK} - (V_{LED} + V_{DS(Q2)} + I_{L2} \times R3) \quad (15)$$

Since the voltage across the MOSFET switch (Q2) is relatively small, as is the voltage across sense resistor R3, we can simplify this to approximately,

$$V_{L(ON-TIME)} = V_{BUCK} - V_{LED} \quad (16)$$

During the off-time, the voltage seen by the inductor is approximately:

$$V_{L(OFF-TIME)} = V_{LED} \quad (17)$$

The value of  $V_{L(OFF-TIME)}$  will be relatively constant, because the LED stack voltage will remain constant. If we rewrite the equation for an inductor inserting what we know about the circuit during the off-time, we get:

$$V_{L(OFF-TIME)} = V_{LED} = L \times \frac{\Delta i}{\Delta t}$$

$$V_{L(OFF-TIME)} = V_{LED} = L \times \frac{(I_{L(MAX)} - I_{L(MIN)})}{\Delta t} \quad (18)$$

Re-arranging this gives:

$$\Delta i \cong t_{OFF} \times \frac{V_{LED}}{L2} \quad (19)$$

From this we can see that the ripple current ( $\Delta i$ ) is proportional to off-time ( $t_{OFF}$ ) multiplied by a voltage which is dominated by  $V_{LED}$  divided by a constant ( $L2$ ).

These equations can be rearranged to calculate the desired value for inductor  $L2$ .

$$L2 \cong t_{OFF} \times \frac{V_{LED}}{\Delta i} \quad (20)$$

Where:

$$t_{OFF} = \frac{\left(1 - \frac{1}{\eta} \times \frac{V_{LED}}{V_{BUCK}}\right)}{f_{SW}} \quad (21)$$

Finally:

$$L2 = \frac{V_{LED} \left(1 - \frac{1}{\eta} \times \frac{V_{LED}}{V_{BUCK}}\right)}{f_{SW} \times \Delta i} \quad (22)$$

Refer to “Design Example” section of the datasheet to better understand the design process.

### SETTING THE LED CURRENT

The LM3444 constant off-time control loop regulates the peak inductor current ( $I_{L2}$ ). The average inductor current equals the average LED current ( $I_{AVE}$ ). Therefore the average LED current is regulated by regulating the peak inductor current.

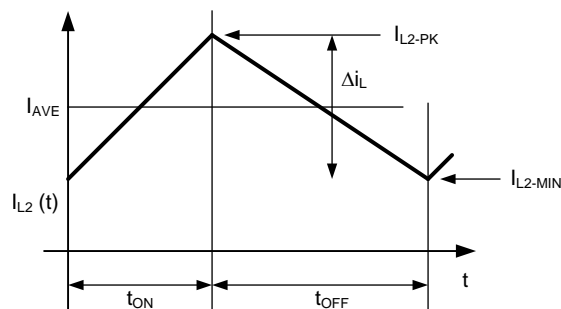

Figure 19. Inductor Current Waveform in CCM

Knowing the desired average LED current,  $I_{AVE}$  and the nominal inductor current ripple,  $\Delta i_L$ , the peak current for an application running in continuous conduction mode (CCM) is defined as follows:

$$I_{L2-PK} = I_{AVE} + \frac{\Delta i_L}{2} \quad (23)$$

Or the LED current would then be,

$$I_{AVE(UNDIM)} = I_{L2-PK(UNDIM)} - \frac{\Delta i_L}{2} \quad (24)$$

This is important to calculate because this peak current multiplied by the sense resistor  $R3$  will determine when the internal comparator is tripped. The internal comparator turns the control MOSFET off once the peak sensed voltage reaches 750 mV.

$$I_{L-PK(UNDIM)} = \frac{750 \text{ mV}}{R3} \quad (25)$$

**Current Limit:** The trip voltage on the PWM comparator is 750 mV. However, if there is a short circuit or an excessive load on the output, higher than normal switch currents will cause a voltage above 1.27V on the ISNS pin which will trip the I-LIM comparator. The I-LIM comparator will reset the RS latch, turning off Q2. It will also inhibit the Start Pulse Generator and the COFF comparator by holding the COFF pin low. A delay circuit will prevent the start of another cycle for 180  $\mu$ s.

### VALLEY FILL CAPACITORS

Determining voltage rating and capacitance value of the valley-fill capacitors:

The maximum voltage seen by the valley-fill capacitors is:

$$V_{VF-CAP} = \frac{V_{AC(MAX)}\sqrt{2}}{\#stages} \quad (26)$$

This is, of course, if the capacitors chosen have identical capacitance values and split the line voltage equally. Often a 20% difference in capacitance could be observed between like capacitors. Therefore a voltage rating margin of 25% to 50% should be considered.

#### Determining the capacitance value of the valley-fill capacitors:

The valley fill capacitors should be sized to supply energy to the buck converter ( $V_{BUCK}$ ) when the input line is less than its peak divided by the number of stages used in the valley fill ( $t_x$ ). The capacitance value should be calculated for the maximum LED current.

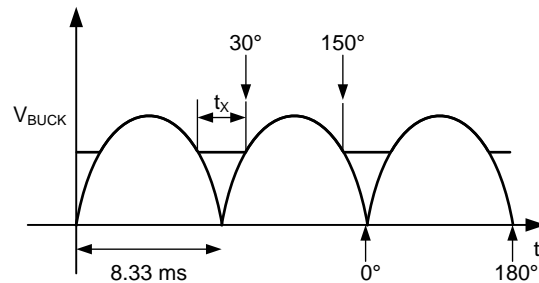

**Figure 20. Two Stage Valley-Ffill  $V_{BUCK}$  Voltage**

From the above illustration and the equation for current in a capacitor,  $i = C \times dV/dt$ , the amount of capacitance needed at  $V_{BUCK}$  will be calculated as follows:

At 60Hz, and a valley-fill circuit of two stages, the hold up time ( $t_x$ ) required at  $V_{BUCK}$  is calculated as follows. The total angle of an AC half cycle is 180° and the total time of a half AC line cycle is 8.33 ms. When the angle of the AC waveform is at 30° and 150°, the voltage of the AC line is exactly 1/2 of its peak. With a two stage valley-fill circuit, this is the point where the LED string switches from power being derived from AC line to power being derived from the hold up capacitors (C7 and C9). 60° out of 180° of the cycle or 1/3 of the cycle the power is derived from the hold up capacitors ( $1/3 \times 8.33 \text{ ms} = 2.78 \text{ ms}$ ). This is equal to the hold up time ( $dt$ ) from the above equation, and  $dv$  is the amount of voltage the circuit is allowed to droop. From the next section ("Determining Maximum Number of Series Connected LEDs Allowed") we know the minimum  $V_{BUCK}$  voltage will be about 45V for a 90V<sub>AC</sub> to 135V<sub>AC</sub> line. At 90V<sub>AC</sub> low line operating condition input, 1/2 of the peak voltage is 64V. Therefore with some margin the voltage at  $V_{BUCK}$  can not droop more than about 15V ( $dv$ ). ( $i$ ) is equal to ( $P_{OUT}/V_{BUCK}$ ), where  $P_{OUT}$  is equal to ( $V_{LED} \times I_{LED}$ ). Total capacitance (C7 in parallel with C9) can now be calculated. See "Design Example" section for further calculations of the valley-fill capacitors.

#### Determining Maximum Number of Series Connected LEDs Allowed:

The LM3444 is an off-line buck topology LED driver. A buck converter topology requires that the input voltage ( $V_{BUCK}$ ) of the output circuit must be greater than the voltage of the LED stack ( $V_{LED}$ ) for proper regulation. One must determine what the minimum voltage observed by the buck converter will be before the maximum number of LEDs allowed can be determined. Two variables will have to be determined in order to accomplish this.

1. AC line operating voltage. This is usually 90V<sub>AC</sub> to 135V<sub>AC</sub> for North America. Although the LM3444 can

operate at much lower and higher input voltages a range is needed to illustrate the design process.

2. How many stages are implemented in the valley-fill circuit (1, 2 or 3).

In this example the most common valley-fill circuit will be used (two stages).

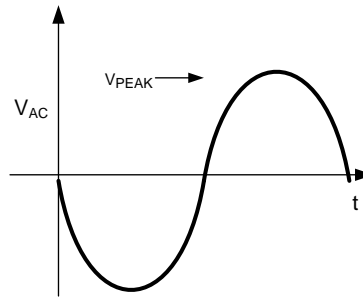

Figure 21. AC Line

Figure 21 shows the AC waveform. One can easily see that the peak voltage ( $V_{PEAK}$ ) will always be:

$$V_{AC-RMS-PK} \sqrt{2} \quad (27)$$

The voltage at  $V_{BUCK}$  with a valley fill stage of two will look similar to the waveforms of Figure 20.

The purpose of the valley fill circuit is to allow the buck converter to pull power directly off of the AC line when the line voltage is greater than its peak voltage divided by two (two stage valley fill circuit). During this time, the capacitors within the valley fill circuit (C7 and C8) are charged up to the peak of the AC line voltage. Once the line drops below its peak divided by two, the two capacitors are placed in parallel and deliver power to the buck converter. One can now see that if the peak of the AC line voltage is lowered due to variations in the line voltage the DC offset ( $V_{DC}$ ) will lower.  $V_{DC}$  is the lowest value that voltage  $V_{BUCK}$  will encounter.

$$V_{BUCK(MIN)} = \frac{V_{AC-RMS(MIN)} \sqrt{2} \times \text{SIN}(\theta)}{\#stages} \quad (28)$$

Example:

Line voltage =  $90V_{AC}$  to  $135V_{AC}$

Valley-Fill = two stage

$$V_{BUCK(MIN)} = \frac{90 \sqrt{2} \times \text{SIN}(135^\circ)}{2} = 45V \quad (29)$$

Depending on what type and value of capacitors are used, some derating should be used for voltage droop when the capacitors are delivering power to the buck converter. With this derating, the lowest voltage the buck converter will see is about 42.5V in this example.

To determine how many LEDs can be driven, take the minimum voltage the buck converter will see (42.5V) and divide it by the worst case forward voltage drop of a single LED.

Example:  $42.5V/3.7V = 11.5$  LEDs (11 LEDs with margin)

## OUTPUT CAPACITOR

A capacitor placed in parallel with the LED or array of LEDs can be used to reduce the LED current ripple while keeping the same average current through both the inductor and the LED array. With a buck topology the output inductance (L2) can now be lowered, making the magnetics smaller and less expensive. With a well designed converter, you can assume that all of the ripple will be seen by the capacitor, and not the LEDs. One must ensure that the capacitor you choose can handle the RMS current of the inductor. Refer to manufacturer's datasheets to ensure compliance. Usually an X5R or X7R capacitor between 1  $\mu F$  and 10  $\mu F$  of the proper voltage rating will be sufficient.

## SWITCHING MOSFET

The main switching MOSFET should be chosen with efficiency and robustness in mind. The maximum voltage across the switching MOSFET will equal:

$$V_{DS(MAX)} = V_{AC-RMS(MAX)}\sqrt{2} \quad (30)$$

The average current rating should be greater than:

$$I_{DS-MAX} = I_{LED(AVE)}(D_{MAX}) \quad (31)$$

## RE-CIRCULATING DIODE

The LM3444 Buck converter requires a re-circulating diode D10 (see the Typical Application circuit [Figure 11](#)) to carry the inductor current during the MOSFET Q2 off-time. The most efficient choice for D10 is a diode with a low forward drop and near-zero reverse recovery time that can withstand a reverse voltage of the maximum voltage seen at  $V_{BUCK}$ . For a common  $110V_{AC} \pm 20\%$  line, the reverse voltage could be as high as 190V.

$$V_D \geq V_{AC-RMS(MAX)}\sqrt{2} \quad (32)$$

The current rating must be at least:

$$I_D = 1 - (D_{MIN}) \times I_{LED(AVE)} \quad (33)$$

Or:

$$I_D = \left(1 - \frac{V_{LED(MIN)}}{V_{BUCK(MAX)}}\right) \times I_{LED(AVE)} \quad (34)$$

## Design Example

The following design example illustrates the process of calculating external component values.

### Known:

1. Input voltage range ( $90V_{AC} - 135V_{AC}$ )
2. Number of LEDs in series = 7
3. Forward voltage drop of a single LED = 3.6V
4. LED stack voltage = ( $7 \times 3.6V$ ) = 25.2V

### Choose:

1. Nominal switching frequency,  $f_{SW-TARGET} = 250$  kHz
2.  $I_{LED(AVE)} = 400$  mA
3.  $\Delta i$  (usually 15% - 30% of  $I_{LED(AVE)}$ ) = ( $0.30 \times 400$  mA) = 120 mA
4. Valley fill stages (1,2, or 3) = 2
5. Assumed minimum efficiency = 80%

### Calculate:

1. Calculate minimum voltage  $V_{BUCK}$  equals:  $V_{BUCK(MIN)} = \frac{90\sqrt{2} \times \sin(135^\circ)}{2} = 45V$
2. Calculate maximum voltage  $V_{BUCK}$  equals:  $V_{BUCK(MAX)} = 135\sqrt{2} = 190V$
3. Calculate  $t_{OFF}$  at  $V_{BUCK}$  nominal line voltage:  $t_{OFF} = \frac{\left(1 - \frac{1}{0.8} \times \frac{25.2V}{115\sqrt{2}}\right)}{(250 \text{ kHz})} = 3.23 \mu s$
4. Calculate  $t_{ON(MIN)}$  at high line to ensure that  $t_{ON(MIN)} > 200$  ns:

$$t_{ON(MIN)} = \frac{\left(\frac{1}{0.8} \times \frac{25.2V}{135\sqrt{2}}\right)}{\left(1 - \frac{1}{0.8} \times \frac{25.2V}{135\sqrt{2}}\right)} \times 3.23 \mu s = 638 \text{ ns} \quad (35)$$

5. Calculate C11 and R4:



6. Choose current through R4: (between 50  $\mu$ A and 100  $\mu$ A) 70  $\mu$ A  $R4 = \frac{V_{LED}}{I_{COLL}} = 360 \text{ k}\Omega$
7. Use a standard value of 365  $\text{k}\Omega$

8. Calculate C11:  $C11 = \left( \frac{V_{LED}}{R4} \right) \left( \frac{t_{OFF}}{1.276} \right) = 175 \text{ pF}$

9. Use standard value of 120 pF

10. Calculate ripple current: 400 mA X 0.30 = 120 mA

11. Calculate inductor value at  $t_{OFF} = 3 \mu\text{s}$ :  $L2 = \frac{25.2V \left( 1 - \frac{1}{0.8} \times \frac{25.2V}{115\sqrt{2}} \right)}{(350 \text{ kHz} \times 0.1A)} = 580 \mu\text{H}$

12. Choose C10: 1.0  $\mu$ F 200V

13. Calculate valley-fill capacitor values:

$V_{AC}$  low line = 90V<sub>AC</sub>,  $V_{BUCK}$  minimum equals 60V. Set droop for 20V maximum at full load and low

line.  $i = C \frac{dv}{dt}$  equals  $P_{OUT}/V_{BUCK}$  (270 mA), dV equals 20V,

dt equals 2.77 ms, and

then  $C_{TOTAL}$  equals 37  $\mu$ F.

Therefore, C7 = C9 = 22  $\mu$ F

## LM3444 Design Example 1

Input = 90V<sub>AC</sub> to 135V<sub>AC</sub>; V<sub>LED</sub> = 7 x HB LED String Application at 400 mA

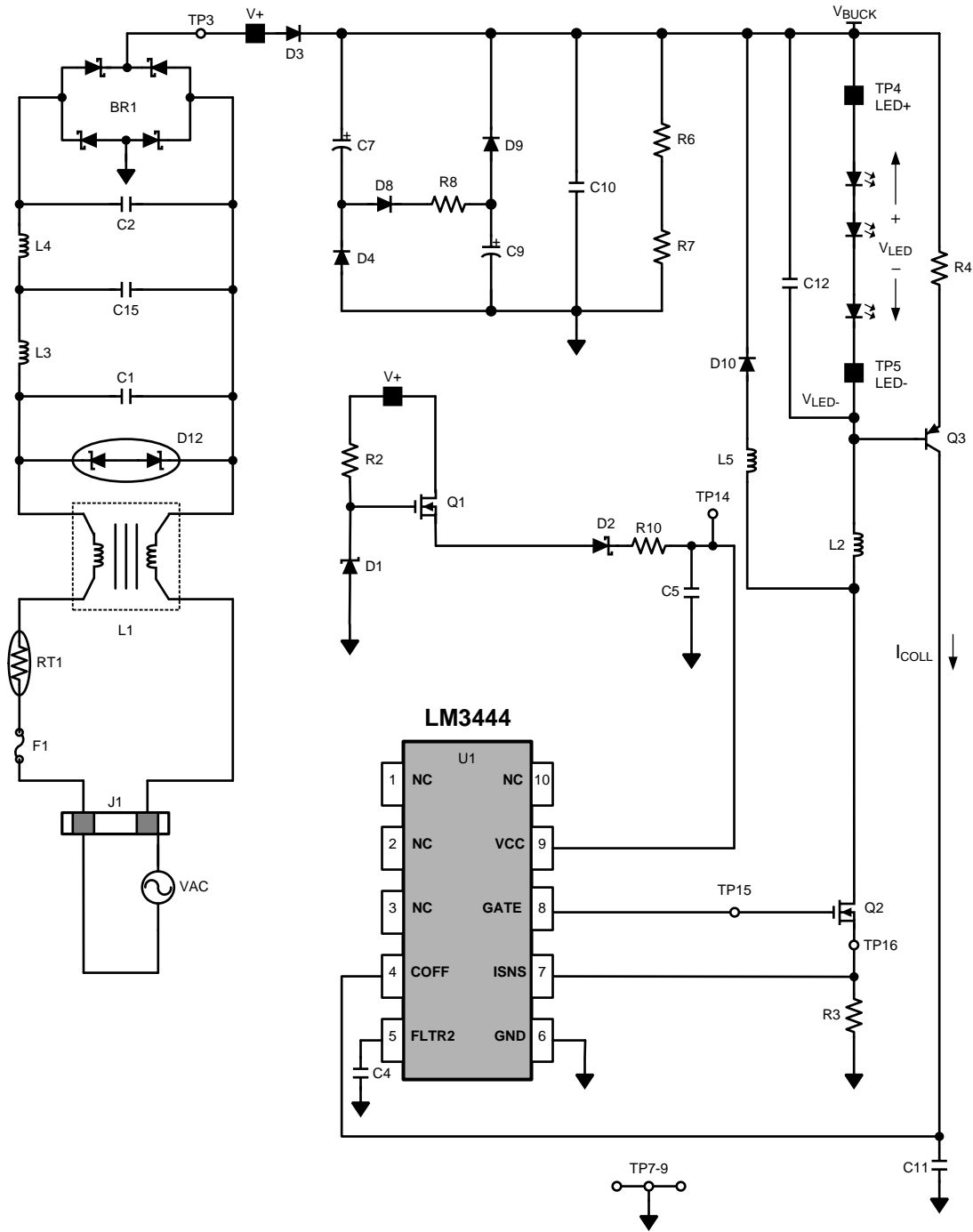

**Table 1. Bill of Materials**

Qty	Ref Des	Description	Mfr	Mfr PN
1	U1	IC, CTRLR, DRVR-LED, VSSOP	NSC	LM3444MM
1	BR1	Bridge Rectifier, SMT, 400V, 800 mA	DiodesInc	HD04-T
1	L1	Common mode filter DIP4NS, 900 mA, 700 $\mu$ H	Panasonic	ELF-11090E
1	L2	Inductor, SHLD, SMT, 1A, 470 $\mu$ H	Coilcraft	MSS1260-474-KLB
2	L3, L4	Diff mode inductor, 500 mA 1 mH	Coilcraft	MSS1260-105KL-KLB
1	L5	Bead Inductor, 160 $\Omega$ , 6A	Steward	HI1206T161R-10
3	C1, C2, C15	Cap, Film, X2Y2, 12.5MM, 250V <sub>AC</sub> , 20%, 10 nF	Panasonic	ECQ-U2A103ML
1	C4	Cap, X7R, 0603, 16V, 10%, 100 nF	Murata	GRM188R71C104KA01D
2	C5, C6	Cap, X5R, 1210, 25V, 10%, 22 $\mu$ F	Murata	GRM32ER61E226KE15L
2	C7, C9	Cap, AL, 200V, 105C, 20%, 33 $\mu$ F	UCC	EKXG201ELL330MK20S
1	C10	Cap, Film, 250V, 5%, 10 nF	Epcos	B32521C3103J
1	C12	Cap, X7R, 1206, 50V, 10%, 1.0 $\mu$ F	Kemet	C1206F105K5RACTU
1	C11	Cap, C0G, 0603, 100V, 5%, 120 pF	Murata	GRM1885C2A121JA01D
1	D1	Diode, ZNR, SOT23, 15V, 5%	OnSemi	BZX84C15LT1G
2	D2, D13	Diode, SCH, SOD123, 40V, 120 mA	NXP	BAS40H
4	D3, D4, D8, D9	Diode, FR, SOD123, 200V, 1A	Rohm	RF071M2S
1	D10	Diode, FR, SMB, 400V, 1A	OnSemi	MURS140T3G
1	D12	TVS, VBR = 144V	Fairchild	SMBJ130CA
1	R2	Resistor, 1206, 1%, 100 k $\Omega$	Panasonic	ERJ-8ENF1003V
1	R3	Resistor, 1210, 5%, 1.8 $\Omega$	Panasonic	ERJ-14RQJ1R8U
1	R4	Resistor, 0603, 1%, 576 k $\Omega$	Panasonic	ERJ-3EKF5763V
2	R6, R7	Resistor, 0805, 1%, 1.00 M $\Omega$	Rohm	MCR10EZHF1004
2	R8, R10	Resistor, 1206, 0.0 $\Omega$	Yageo	RC1206JR-070RL
1	R9	Resistor, 1812, 0.0 $\Omega$		
1	RT1	Thermistor, 120V, 1.1A, 50 $\Omega$ @ 25°C	Thermometrics	CL-140
2	Q1, Q2	XSTR, NFET, DPAK, 300V, 4A	Fairchild	FQD7N30TF
1	Q3	XSTR, PNP, SOT23, 300V, 500 mA	Fairchild	MMBTA92
1	J1	Terminal Block 2 pos	Phoenix Contact	1715721
1	F1	Fuse, 125V, 1,25A	bel	SSQ 1.25

**PACKAGING INFORMATION**

Orderable Device	Status (1)	Package Type	Package Drawing	Pins	Package Qty	Eco Plan (2)	Lead/Ball Finish	MSL Peak Temp (3)	Op Temp (°C)	Top-Side Markings (4)	Samples
LM3444MA/NOPB	ACTIVE	SOIC	D	8	95	Green (RoHS & no Sb/Br)	CU SN	Level-1-260C-UNLIM	-40 to 125	L3444 MA	<a href="#">Samples</a>
LM3444MAX/NOPB	ACTIVE	SOIC	D	8	2500	Green (RoHS & no Sb/Br)	CU SN	Level-1-260C-UNLIM	-40 to 125	L3444 MA	<a href="#">Samples</a>
LM3444MM/NOPB	ACTIVE	VSSOP	DGS	10	1000	Green (RoHS & no Sb/Br)	CU SN	Level-1-260C-UNLIM	-40 to 125	SZTB	<a href="#">Samples</a>
LM3444MMX/NOPB	ACTIVE	VSSOP	DGS	10	3500	Green (RoHS & no Sb/Br)	CU SN	Level-1-260C-UNLIM	-40 to 125	SZTB	<a href="#">Samples</a>

(1) The marketing status values are defined as follows:

**ACTIVE:** Product device recommended for new designs.

**LIFEBUY:** TI has announced that the device will be discontinued, and a lifetime-buy period is in effect.

**NRND:** Not recommended for new designs. Device is in production to support existing customers, but TI does not recommend using this part in a new design.

**PREVIEW:** Device has been announced but is not in production. Samples may or may not be available.

**OBSOLETE:** TI has discontinued the production of the device.

(2) Eco Plan - The planned eco-friendly classification: Pb-Free (RoHS), Pb-Free (RoHS Exempt), or Green (RoHS & no Sb/Br) - please check <http://www.ti.com/productcontent> for the latest availability information and additional product content details.

**TBD:** The Pb-Free/Green conversion plan has not been defined.

**Pb-Free (RoHS):** TI's terms "Lead-Free" or "Pb-Free" mean semiconductor products that are compatible with the current RoHS requirements for all 6 substances, including the requirement that lead not exceed 0.1% by weight in homogeneous materials. Where designed to be soldered at high temperatures, TI Pb-Free products are suitable for use in specified lead-free processes.

**Pb-Free (RoHS Exempt):** This component has a RoHS exemption for either 1) lead-based flip-chip solder bumps used between the die and package, or 2) lead-based die adhesive used between the die and leadframe. The component is otherwise considered Pb-Free (RoHS compatible) as defined above.

**Green (RoHS & no Sb/Br):** TI defines "Green" to mean Pb-Free (RoHS compatible), and free of Bromine (Br) and Antimony (Sb) based flame retardants (Br or Sb do not exceed 0.1% by weight in homogeneous material)

(3) MSL, Peak Temp. -- The Moisture Sensitivity Level rating according to the JEDEC industry standard classifications, and peak solder temperature.

(4) Only one of markings shown within the brackets will appear on the physical device.

**Important Information and Disclaimer:** The information provided on this page represents TI's knowledge and belief as of the date that it is provided. TI bases its knowledge and belief on information provided by third parties, and makes no representation or warranty as to the accuracy of such information. Efforts are underway to better integrate information from third parties. TI has taken and continues to take reasonable steps to provide representative and accurate information but may not have conducted destructive testing or chemical analysis on incoming materials and chemicals. TI and TI suppliers consider certain information to be proprietary, and thus CAS numbers and other limited information may not be available for release.

In no event shall TI's liability arising out of such information exceed the total purchase price of the TI part(s) at issue in this document sold by TI to Customer on an annual basis.



## TAPE AND REEL INFORMATION



### QUADRANT ASSIGNMENTS FOR PIN 1 ORIENTATION IN TAPE



\*All dimensions are nominal

Device	Package Type	Package Drawing	Pins	SPQ	Reel Diameter (mm)	Reel Width W1 (mm)	A0 (mm)	B0 (mm)	K0 (mm)	P1 (mm)	W (mm)	Pin1 Quadrant
LM3444MAX/NOPB	SOIC	D	8	2500	330.0	12.4	6.5	5.4	2.0	8.0	12.0	Q1
LM3444MM/NOPB	VSSOP	DGS	10	1000	178.0	12.4	5.3	3.4	1.4	8.0	12.0	Q1
LM3444MMX/NOPB	VSSOP	DGS	10	3500	330.0	12.4	5.3	3.4	1.4	8.0	12.0	Q1

**TAPE AND REEL BOX DIMENSIONS**

\*All dimensions are nominal

Device	Package Type	Package Drawing	Pins	SPQ	Length (mm)	Width (mm)	Height (mm)
LM3444MAX/NOPB	SOIC	D	8	2500	367.0	367.0	35.0
LM3444MM/NOPB	VSSOP	DGS	10	1000	203.0	190.0	41.0
LM3444MMX/NOPB	VSSOP	DGS	10	3500	367.0	367.0	35.0

DGS (S-PDSO-G10)

PLASTIC SMALL-OUTLINE PACKAGE



- NOTES:
- A. All linear dimensions are in millimeters.
  - B. This drawing is subject to change without notice.
  - C. Body dimensions do not include mold flash or protrusion.
  - D. Falls within JEDEC MO-187 variation BA.



D (R-PDSO-G8)

PLASTIC SMALL OUTLINE



- NOTES:
- A. All linear dimensions are in inches (millimeters).
  - B. This drawing is subject to change without notice.
  - C. Body length does not include mold flash, protrusions, or gate burrs. Mold flash, protrusions, or gate burrs shall not exceed 0.006 (0,15) each side.
  - D. Body width does not include interlead flash. Interlead flash shall not exceed 0.017 (0,43) each side.
  - E. Reference JEDEC MS-012 variation AA.

## IMPORTANT NOTICE

Texas Instruments Incorporated and its subsidiaries (TI) reserve the right to make corrections, enhancements, improvements and other changes to its semiconductor products and services per JESD46, latest issue, and to discontinue any product or service per JESD48, latest issue. Buyers should obtain the latest relevant information before placing orders and should verify that such information is current and complete. All semiconductor products (also referred to herein as "components") are sold subject to TI's terms and conditions of sale supplied at the time of order acknowledgment.

TI warrants performance of its components to the specifications applicable at the time of sale, in accordance with the warranty in TI's terms and conditions of sale of semiconductor products. Testing and other quality control techniques are used to the extent TI deems necessary to support this warranty. Except where mandated by applicable law, testing of all parameters of each component is not necessarily performed.

TI assumes no liability for applications assistance or the design of Buyers' products. Buyers are responsible for their products and applications using TI components. To minimize the risks associated with Buyers' products and applications, Buyers should provide adequate design and operating safeguards.

TI does not warrant or represent that any license, either express or implied, is granted under any patent right, copyright, mask work right, or other intellectual property right relating to any combination, machine, or process in which TI components or services are used. Information published by TI regarding third-party products or services does not constitute a license to use such products or services or a warranty or endorsement thereof. Use of such information may require a license from a third party under the patents or other intellectual property of the third party, or a license from TI under the patents or other intellectual property of TI.

Reproduction of significant portions of TI information in TI data books or data sheets is permissible only if reproduction is without alteration and is accompanied by all associated warranties, conditions, limitations, and notices. TI is not responsible or liable for such altered documentation. Information of third parties may be subject to additional restrictions.

Resale of TI components or services with statements different from or beyond the parameters stated by TI for that component or service voids all express and any implied warranties for the associated TI component or service and is an unfair and deceptive business practice. TI is not responsible or liable for any such statements.

Buyer acknowledges and agrees that it is solely responsible for compliance with all legal, regulatory and safety-related requirements concerning its products, and any use of TI components in its applications, notwithstanding any applications-related information or support that may be provided by TI. Buyer represents and agrees that it has all the necessary expertise to create and implement safeguards which anticipate dangerous consequences of failures, monitor failures and their consequences, lessen the likelihood of failures that might cause harm and take appropriate remedial actions. Buyer will fully indemnify TI and its representatives against any damages arising out of the use of any TI components in safety-critical applications.

In some cases, TI components may be promoted specifically to facilitate safety-related applications. With such components, TI's goal is to help enable customers to design and create their own end-product solutions that meet applicable functional safety standards and requirements. Nonetheless, such components are subject to these terms.

No TI components are authorized for use in FDA Class III (or similar life-critical medical equipment) unless authorized officers of the parties have executed a special agreement specifically governing such use.

Only those TI components which TI has specifically designated as military grade or "enhanced plastic" are designed and intended for use in military/aerospace applications or environments. Buyer acknowledges and agrees that any military or aerospace use of TI components which have **not** been so designated is solely at the Buyer's risk, and that Buyer is solely responsible for compliance with all legal and regulatory requirements in connection with such use.

TI has specifically designated certain components as meeting ISO/TS16949 requirements, mainly for automotive use. In any case of use of non-designated products, TI will not be responsible for any failure to meet ISO/TS16949.

### Products

Audio	<a href="http://www.ti.com/audio">www.ti.com/audio</a>
Amplifiers	<a href="http://amplifier.ti.com">amplifier.ti.com</a>
Data Converters	<a href="http://dataconverter.ti.com">dataconverter.ti.com</a>
DLP® Products	<a href="http://www.dlp.com">www.dlp.com</a>
DSP	<a href="http://dsp.ti.com">dsp.ti.com</a>
Clocks and Timers	<a href="http://www.ti.com/clocks">www.ti.com/clocks</a>
Interface	<a href="http://interface.ti.com">interface.ti.com</a>
Logic	<a href="http://logic.ti.com">logic.ti.com</a>
Power Mgmt	<a href="http://power.ti.com">power.ti.com</a>
Microcontrollers	<a href="http://microcontroller.ti.com">microcontroller.ti.com</a>
RFID	<a href="http://www.ti-rfid.com">www.ti-rfid.com</a>
OMAP Applications Processors	<a href="http://www.ti.com/omap">www.ti.com/omap</a>
Wireless Connectivity	<a href="http://www.ti.com/wirelessconnectivity">www.ti.com/wirelessconnectivity</a>

### Applications

Automotive and Transportation	<a href="http://www.ti.com/automotive">www.ti.com/automotive</a>
Communications and Telecom	<a href="http://www.ti.com/communications">www.ti.com/communications</a>
Computers and Peripherals	<a href="http://www.ti.com/computers">www.ti.com/computers</a>
Consumer Electronics	<a href="http://www.ti.com/consumer-apps">www.ti.com/consumer-apps</a>
Energy and Lighting	<a href="http://www.ti.com/energy">www.ti.com/energy</a>
Industrial	<a href="http://www.ti.com/industrial">www.ti.com/industrial</a>
Medical	<a href="http://www.ti.com/medical">www.ti.com/medical</a>
Security	<a href="http://www.ti.com/security">www.ti.com/security</a>
Space, Avionics and Defense	<a href="http://www.ti.com/space-avionics-defense">www.ti.com/space-avionics-defense</a>
Video and Imaging	<a href="http://www.ti.com/video">www.ti.com/video</a>

### TI E2E Community

[e2e.ti.com](http://e2e.ti.com)

# Mouser Electronics

Authorized Distributor

Click to View Pricing, Inventory, Delivery & Lifecycle Information:

[Texas Instruments:](#)

[LM3444-120VFLBK/NOPB](#) [LM3444-230VFLBK/NOPB](#) [LM3444-EDSNEV/NOPB](#)