

SF2062A

**229.25 MHz
SAW Filter**

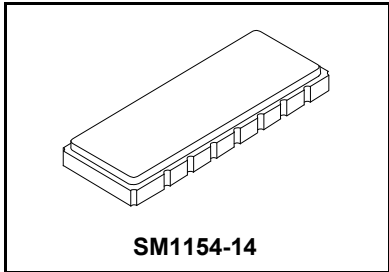

- Quartz Temperature Stability
- Small Size
- Hermetic 11.5x4.0 mm Surface-mount Case
- Complies with Directive 2002/95/EC (RoHS)



Absolute Maximum Ratings

Rating	Value	Units
Maximum Incident Power in Passband	+10	dBm
Maximum DC Voltage Between any 2 Terminals	30	VDC
Storage Temperature Range	-40 to +85	°C
Suitable for Lead-free Soldering - Maximum Soldering Profile	260 °C for 30 s	

Electrical Characteristics

Characteristic	Sym	Notes	Min	Typ	Max	Units
Nominal Center Frequency	f_c	1	229.25			MHz
Insertion Loss at f_c	IL				8.35	dB
3 dB Bandwidth	BW_3		± 150			kHz
Amplitude Ripple, $f_c \pm 100$ kHz				0.9		dB _{p-p}
I/O Impedance				50		ohm
Group Delay Deviation, $f_c \pm 100$ kHz, -20 to +60 °C	GDD			150		ns _{p-p}
Attenuation Referenced to IL:						dB
$f_c \pm 600$ kHz			20			
$f_c \pm 900$ kHz			34			
$f_c \pm 1.2$ MHz			32			
10 MHz to $f_c - 1.2$ MHz, $f_c + 1.2$ MHz to 2000 MHz			20			
Operating Temperature Range	T_A	1	-20		+80	°C

Matching to Unbalanced 50 Ω	External L-C	
Case Style	6	SM1154-14 11.5 x 4.0 mm Nominal Footprint
Lid Symbolization (YY=year, WW=week S=shift, ##=sequence code)		RFM SF2062A YYWWS##



CAUTION: Electrostatic Sensitive Device. Observe precautions for handling.

NOTES:

1. Unless noted otherwise, all specifications apply over the operating temperature range with filter soldered to the specified demonstration board with impedance matching to 50 Ω and measured with 50 Ω network analyzer.
2. Unless noted otherwise, all frequency specifications are referenced to the nominal center frequency, f_c .
3. Rejection is measured as attenuation below the minimum IL point in the passband. Rejection in final user application is dependent on PCB layout and external impedance matching design. See Application Note No. 42 for details.
4. The design, manufacturing process, and specifications of this filter are subject to change.
5. US and international patents may apply.
6. Murata, stylized Murata logo, and Murata N.A., Inc. are registered trademarks of Murata Manufacturing Co., Ltd.

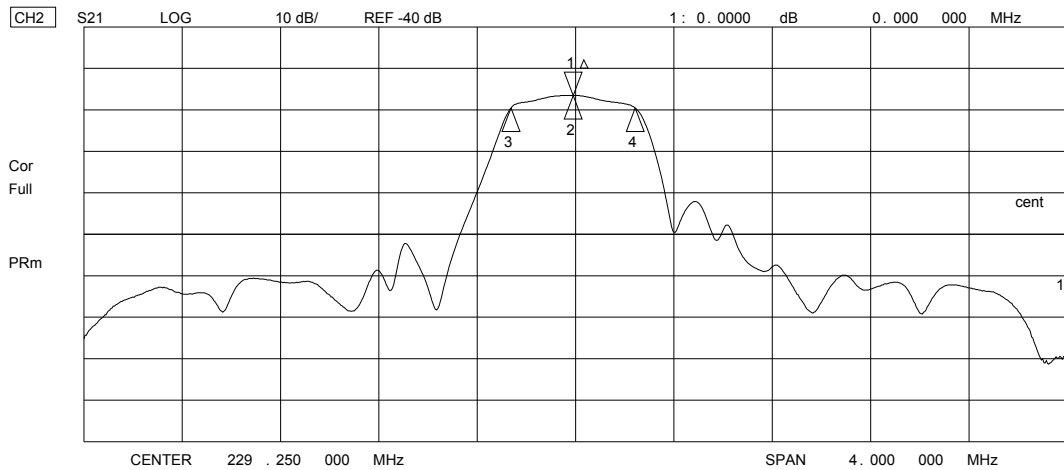
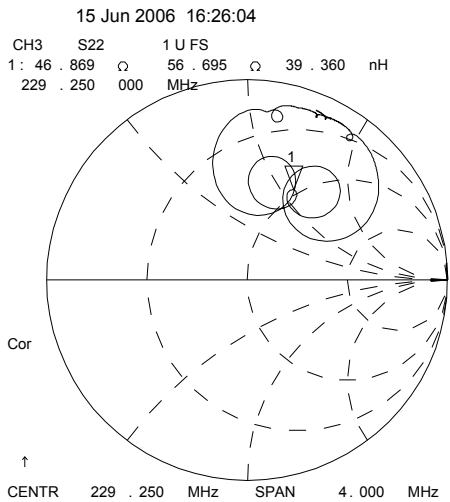
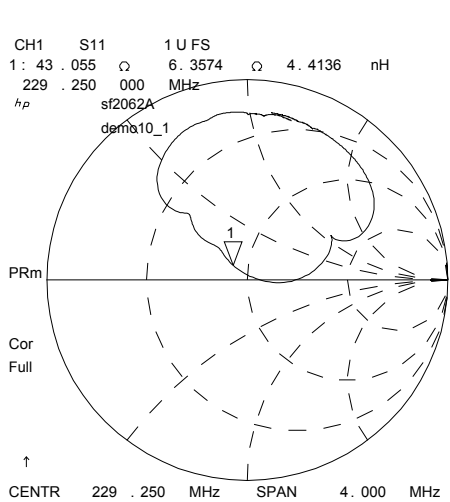

CH1 S11 1 UFS
 1: 46.875 Ω 5.9023 Ω 4.0977 nH
 229.250 000 MHz

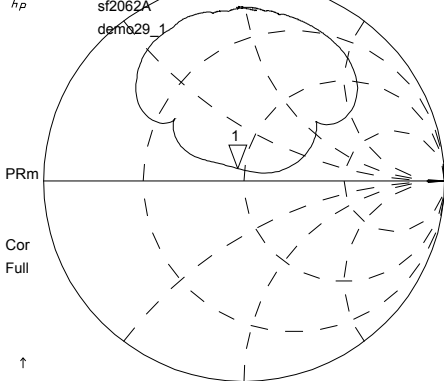

CENTR 229.250 MHz SPAN 4.000 MHz

15 Jun 2006 16:28:39

CH3 S22 1 UFS
 1: 44.410 Ω 47.613 Ω 33.055 nH
 229.250 000 MHz

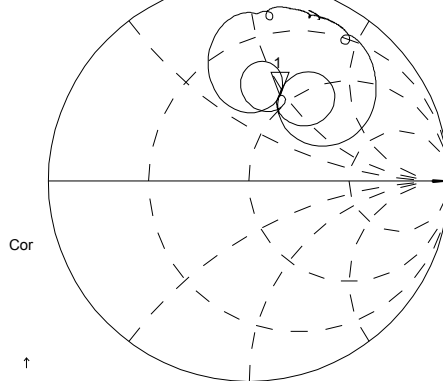

CENTR 229.250 MHz SPAN 4.000 MHz

CH2 S21 LOG 10 dB/ REF -40 dB 1: 0.0000 dB 0.000 000 MHz

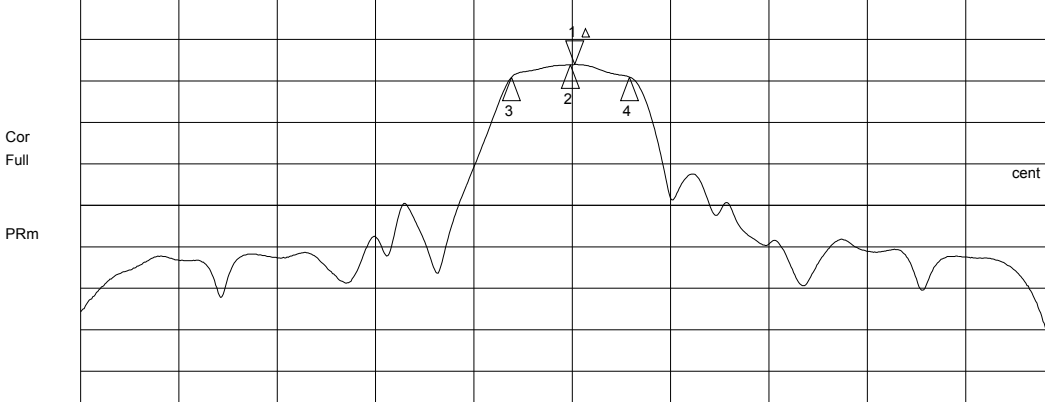

CENTER 229.250 000 MHz SPAN 4.000 000 MHz

CH2 Markers
 Max Δ REF=1
 BW: .480371 MHz
 cent : 229.243919 MHz
 Q: 477.22
 1 loss : -6.0778 dB

15 Jun 2006 16:18:18

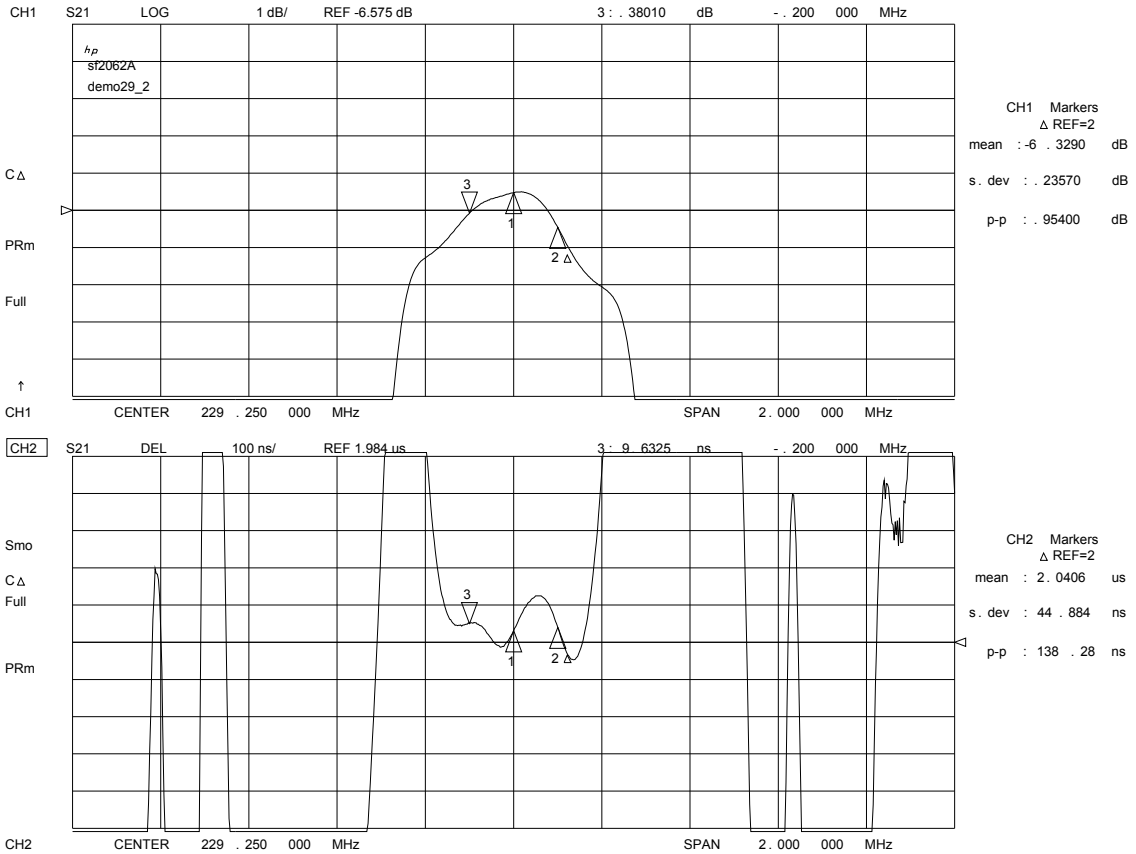

SF2062A Demo Board Rev 2

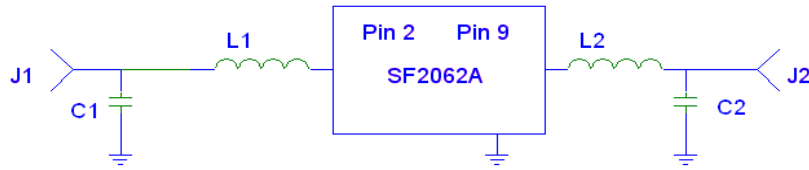

All other pins ground

- PCB=400-1650-001 PCB
- J1, J2=500-0248-002 2 hole flange SMA
- C1=15 pF 500-0003-150 C2=10 pF 500-0003-100
- L1=68 nH 0805CS
- L2=82 nH 0805CS
- Shield=Brass shim stock

SM1154-14 Case

14-Terminal Ceramic Surface-Mount Case

11.5 x 4.0 mm Nominal Footprint

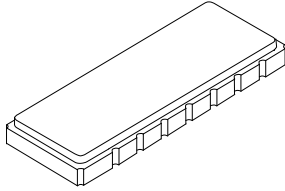

Case Dimensions						
Dimension	mm			Inches		
	Min	Nom	Max	Min	Nom	Max
A	11.4	11.5	11.6	.442	0.450	0.458
B	3.8	4.0	4.2	.150	0.157	.166
C	1.4	1.6	1.8	.057	0.063	.069
D	1.3	1.5	1.7	.053	0.059	.065
E		0.76			0.030	
F		1.27			0.050	
G		1.27			0.050	
H		0.1			0.004	

Electrical Connections	
Connection	Terminals
Input	2
Output	9
Ground	All Others

Materials	
Solder Pad Plating	0.3 to 1.0 μm Gold over 1.27 to 8.89 μm Nickel
Lid Plating	2.0 to 3.0 μm Nickel
Body	Al_2O_3 Ceramic
Pb Free	

Recommended PCB Footprint

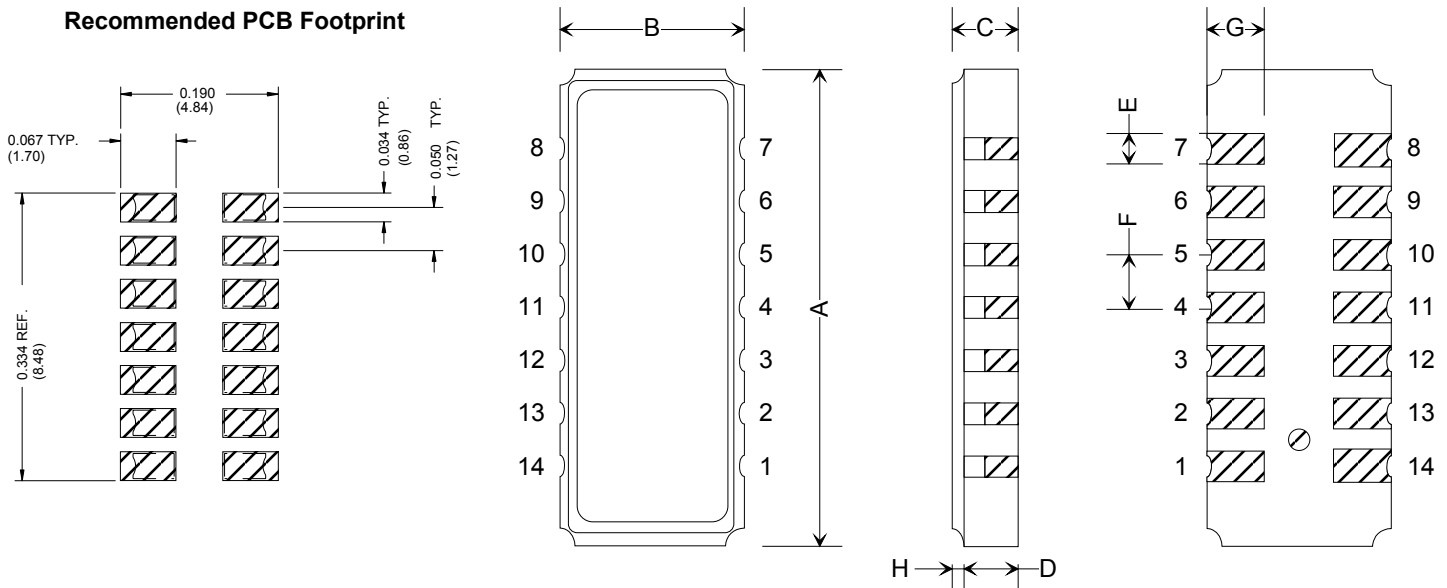

COMPONENT ORIENTATION and DIMENSIONS

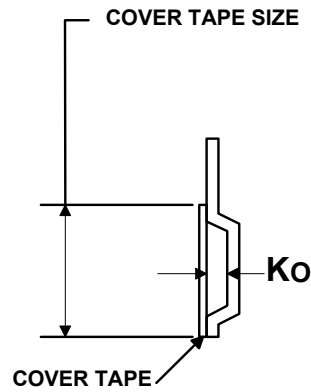
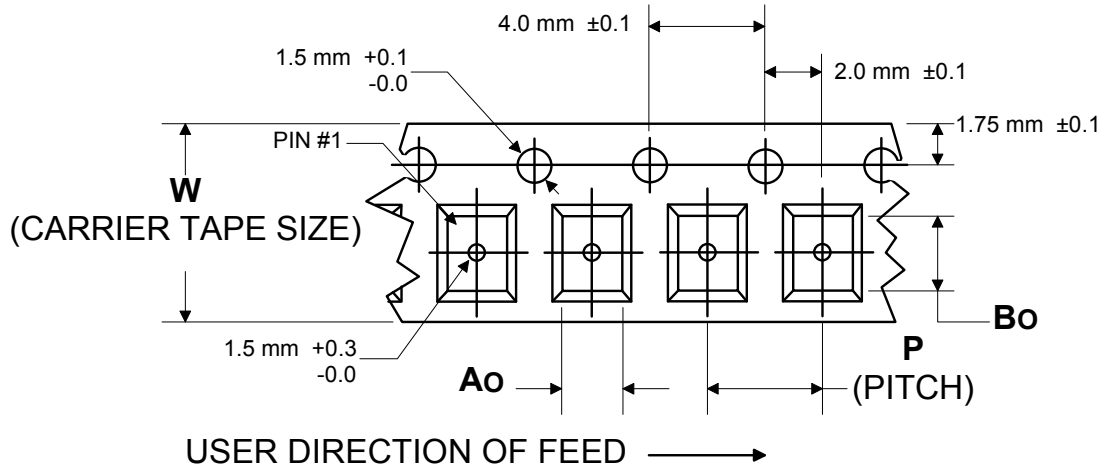

Carrier Tape Dimensions		
Ao	4.55 mm	±0.1
Bo	12.04 mm	±0.1
Ko	2.13 mm	±0.1
Pitch	8.00 mm	±0.1
W	24.00 mm	±0.3

Leader and Trailer specifications (Based upon EIA-481)

Dimensions of the leader and trailer

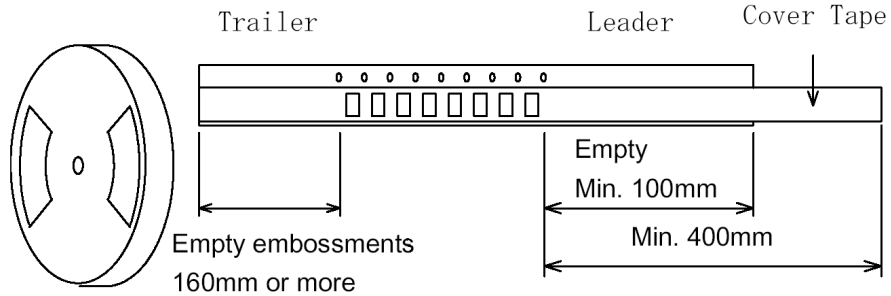

7 Inch Reel Quantity 500														
Symbol	A		N		C		D		B		W ₁		W ₂	
Dimension	178	+0 -4	60	±1	13	+0.5 -0.2	20.2	+1.5 -0	2	±0.5	24.4	+2 -0	30.4	MAX

13 Inch Reel Quantity 2000														
Symbol	A		N		C		D		B		W ₁		W ₂	
Dimension	330	+0 -4	100	±2	13	+0.5 -0.2	20.2	+1.5 -0	2	±0.5	24.4	+2 -0	30.4	MAX

Dimensional drawing of the reel

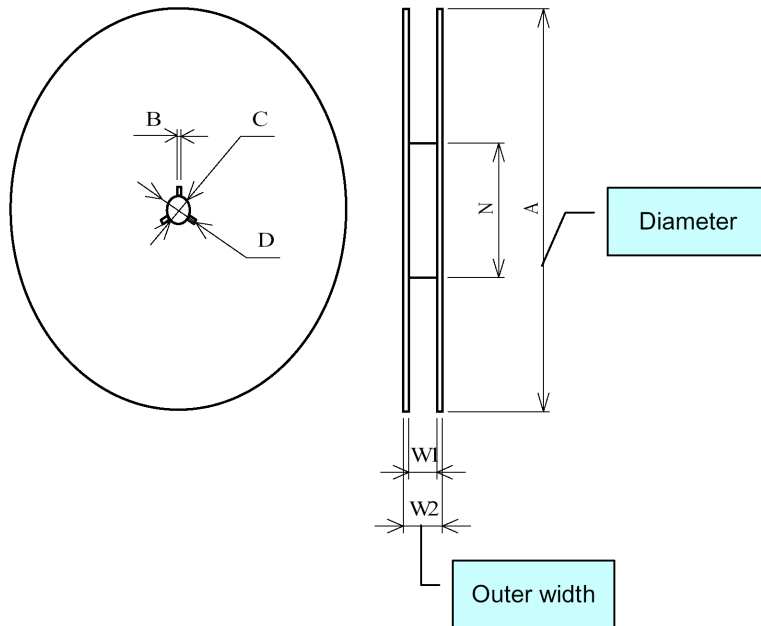

Additional items

(1) Cover tape peeling strength

The cover tape shall be adhered evenly to the carrier tape along both sides in the pulling direction.

The cover tape peeling strength shall be as follows for an angle between the cover tape and the pulling direction of 165° to 180° (see the figure) and a peeling speed of 300mm/min. ±10mm/min.

[EIA-481] 0.1N to 1.3N for a tape width of 12 to 56mm

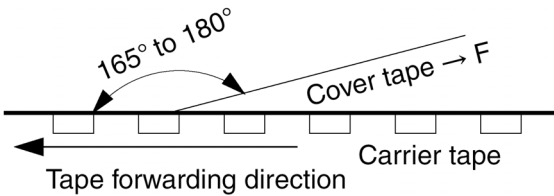

Fixing method

1. Insert the tip of the carrier tape into the groove.
2. Fix the tip of the cover tape with adhesive tape.

Tape material

(1) Carrier tape [anti-charging treatment: carbon used] Surface resistivity: 1×10^8 or less

Material: Polystyrene or Polycarbonate

(2) Cover tape material: Polyester (anti-charging treated) Surface resistivity: 1×10^{12} or less

t = 50 to 100μm

Warranty periods

Cover tape peeling strength and mounting performance of stored components.

2-1. Cover tape peeling strength: One year after delivery (Peeling strength: 0.1N to 1.3N)

Number of missing components

There shall not be two or more consecutive missing components. Also, the maximum number of missing components shall be the larger of one piece or 0.1%.

Storage environment

Keep the product on which taping has been performed to a temperature below 40°C and a humidity within 80% RH. Do not subject in the direct sun.

Reel labels shall follow the format shown below. The long side of the label must measure between 2.75 and 4.0 inches (68 to 100 mm). The short side of the label must measure between 1.5 and 2 inches (38 to 80 mm). Bar codes must conform to AIAG standard B10.

Information that is on the label:

- Device Type: RFM part number
- Code: RFM designated part ID or part date code
- Reel ID: Manufacturing reel identification
- Reel Qty: Quantity of parts on the reel
- Work Order: Manufacturing work order number
- Date: Date product was loaded on tape and reel.
- Company Identification: R. F. Monolithics, Inc.
- *Q. C.: Area for QA stamps, other information is required
- Country of assembly



Examples of acceptable reel labels

Location of label on reel is shown below. Reel labels must be placed entirely on plastic, without covering open sections of the reel. Design of reel must satisfy this requirement. Pin #1 must be located on the side opposite the reel label.

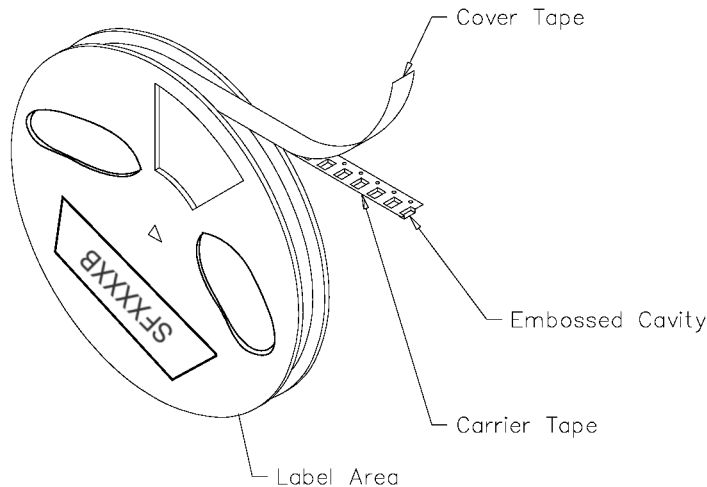

Package for Shipment

	Quantity Per Reel	Number Reels Per Carton	External Carton Dimensions	Reel Weight	Shipping Carton Weight	Total Weight
7 Inch Reel	500	4	254 x 254 x 127 mm 10 x 10 x 5 inches	896 g	448 g	1344 g
	500	10	254 x 254 x 203 mm 10 x 10 x 8 inches	2240 g	448 g	2688 g
	Quantity Per Reel	Number Reels Per Carton	External Carton Dimensions	Reel Weight	Shipping Carton Weight	Total Weight
13 Inch Reel	2000	2	356 x 356 x 102 mm 14 x 14 x 4 inches	1288 g	448 g	1736 g
	2000	4	356 x 356 x 178 mm 14 x 14 x 7 inches	2576 g	448 g	3024 g
	2000	8	356 x 356 x 356 mm 14 x 14 x 14 inches	5152 g	448 g	5600 g

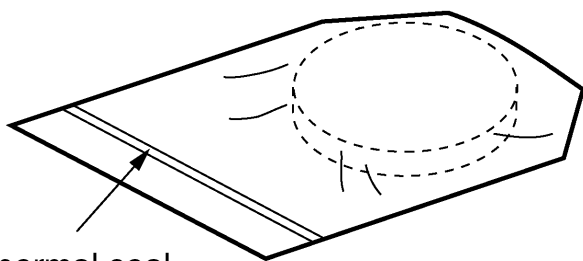
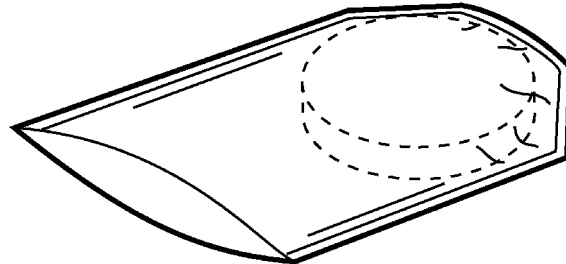

Thermal seal

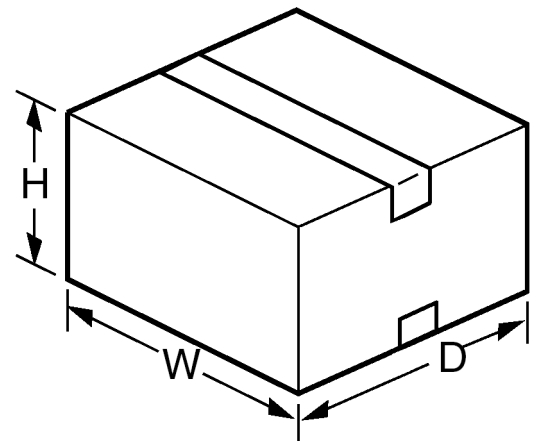

Shipment package

Sealing tape

Mouser Electronics

Authorized Distributor

Click to View Pricing, Inventory, Delivery & Lifecycle Information:

[Murata:](#)

[SF2062A](#)